

# UNION PACIFIC SYSTEM TIMETABLE NO. 7

Central Time east of North Platte, Nebraska, Oakley, Kansas, and on Plainville Branch. Mountain Time west of North Platte, Nebraska, and Oakley, Kansas. Mountain Time east of La Grande, Oregon, and Las Vegas, Nevada; Pacific Time west of La Grande, Oregon and Las Vegas, Nevada.

Pacific Time west of Salt Lake City, Utah on Western District only.

*FOR EMPLOYEES ONLY*



Effective 12:01 A.M., June 12, 1983

# SYSTEM

J.R. DAVIS VICE PRESIDENT-OPERATION

T.P. ROGERS ASST. VICE PRES.-OPERATION

J.R. FERNEY GENERAL SUPT. TRANSPORTATION

## Radio Procedure

12 (R). Radio communication must be attempted before proceeding through the limits of a Form Y train order and engineer and employe in charge named in the Form Y train order must use the following radio procedure:

"Engineer UP Extra 3900 West calling UP General Foreman Smith. Over."

"General Foreman Smith to Engineer UP Extra 3900 West, go ahead. Over."

"Engineer UP Extra 3900 West, I am approaching MP ..... on Form Y Order No. ...., please advise."

"You may proceed from MP ..... to MP ..... on Order No. .... at ..... MPH, repeat ..... MPH (normal speed). Acknowledge. Over."

"Engineer Extra 3900 West. I may proceed from MP ..... to MP ..... on Order No. .... at ..... MPH, repeat ..... MPH (normal speed). Out."

Each time a train stops or starts within the limits of a Form Y train order, the employe in charge named in the train order must be contacted by the engineer before proceeding.

99 (R-1). When radio communication is used to restore a track to service prior to expiration of the protecting order, the employe in charge and subordinates in charge of elements of the work force must use the following radio procedure:

"UP General Foreman A. B. Smith calling Foreman Robert Jones. Over."

"Robert Jones to Smith — go ahead. Over."

"Jones advise when men and machines are clear of westward main track. Over."

"Jones to Smith — Men and machines are clear of westward main track. Over."

"Smith to Jones — Keep men and machines clear. I will release westward main track for service immediately. Do you understand? Over."

"Jones to Smith — Acknowledged. I understand. Out."

(Procedure to be repeated to each employe responsible for any element of work force.) TRACK MUST NOT BE RELEASED FOR SERVICE UNTIL ALL RESPONSIBLE PERSONS HAVE CONFIRMED THEIR UNDERSTANDING.

## SYMBOLS AND ABBREVIATIONS

6 (A). The following letters, placed in column with station name, in timetable indicate:

D — day operator;  
N — night operator;  
R — train register;  
YL — yard limits.

6 (B). The following letters, placed in column provided in the timetable, indicate:

A — automatic interlocking;  
F — fueling station;  
I — manual interlocking;  
P — dispatcher's telephone;  
T — turntable;  
X — crossover;  
Y — wye.

Time per Mile	Miles per Hour	Time per Mile	Miles per Hour	Time per Mile	Miles per Hour	Time per Mile	Miles per Hour	Time per Mile	Miles per Hour
40"	90.	50"	72.	1'	60.	1'10"	51.4	2'	30.
41"	87.8	51"	70.6	1'11"	59.	1'11"	50.7	2'15"	26.6
42"	85.7	52"	69.2	1'12"	58.	1'12"	50.	2'30"	24.
43"	83.7	53"	67.9	1'13"	57.1	1'15"	48.	2'45"	21.8
44"	81.8	54"	66.6	1'14"	56.2	1'20"	45.	3'	20.
45"	80.	55"	65.4	1'15"	55.3	1'25"	42.3	3'30"	17.1
46"	78.3	56"	64.2	1'16"	54.5	1'30"	40.	4'	15.
47"	76.6	57"	63.1	1'17"	53.7	1'35"	37.9	5'	12.
48"	75.	58"	62.	1'18"	52.9	1'40"	36.	6'	10.
49"	73.5	59"	61.	1'19"	52.1	1'45"	34.3	7'	8.6
						1'50"	32.7	8'	7.5
						1'55"	31.3	10'	6.

# INDEX

## General

### Maps — Division:

Nebraska .....	6
Wyoming .....	22
Kansas .....	40
Utah .....	56
California .....	76
Idaho .....	90
Oregon .....	116

### Officers — Division:

Nebraska .....	3
Wyoming .....	3
Kansas .....	4
Utah .....	54
California .....	54
Idaho .....	86
Oregon .....	86

### Radio Procedure..... (Inside front cover)

Speed Restrictions — General..... 1

Speed Table (Time Per Mile)..... (Inside front cover)

### Standard Clock Locations — Division:

Eastern District.....	4
South-Central District .....	55
Northwestern District .....	87

### Symbols and Abbreviations:

Union Pacific..... (Inside front cover)

Consolidated Code ..... 88 |

### Tonnage Rating Tables:

Eastern District.....	330
South-Central District .....	332
Northwestern District .....	334

## Timetables and Speed Restrictions

### Eastern District

#### Nebraska Division —

##### Subdivision:

First.....	8
Second.....	12
Third.....	14

##### Branches:

Albion.....	15
Beatrice.....	18
Cedar Rapids.....	16
Kearney .....	17
Loup City .....	16
Norfolk.....	15
North Platte.....	20
North Platte Cut-Off.....	21
Old Main Line.....	15
Ord .....	16
Stromsburg.....	19

#### Wyoming Division —

##### Subdivision:

First.....	24
Second.....	26
Third.....	30
Fourth.....	32

##### Branches:

Boulder .....	36
Coalmont .....	37
Dent .....	35
Encampment.....	37
Fort Collins .....	35
Ontario.....	38
Park City.....	38
South Pass .....	38

#### Kansas Division —

##### Subdivision:

First.....	42
Second.....	44
Denver Cut-Off-Salina .....	46
Denver Cut-Off-Denver.....	48

Branches:	
Bestwall Spur.....	51
Grand Island.....	51
McPherson.....	53
Plainville.....	52
St. Joseph.....	50
Solomon.....	53

South-Central District

**Utah Division —**

Subdivision:	
First.....	58
Second.....	62
Third.....	64
Provo.....	68
Branches:	
Cache Valley.....	72
Cedar City.....	70
Evona.....	73
Fillmore.....	70
Hill Field.....	73
Iron Mountain.....	70
Little Mountain.....	73
Malad.....	72
Mead Lake.....	71
Pioche-Prince.....	70
Syracuse.....	72

**California Division —**

Subdivision:	
First.....	78
Second.....	80
Branches:	
Anaheim.....	83
Boulder City.....	84
Crestmore.....	84
Glendale.....	84
Lakewood.....	84
Pasadena.....	84
San Pedro.....	82

Northwestern District

**Idaho Division —**

Subdivision:	
First.....	92
Second.....	94
Third.....	96
Fourth.....	98
Branches:	
Aberdeen.....	110
Boise.....	109
Boise Cut-Off.....	105
Conda.....	101
Cumberland.....	100
Dry Valley.....	101
East Belt.....	112
Elkol.....	100
Gay.....	110
Goshen.....	110
Grace.....	100
Hill City.....	103
Homedale.....	109
Idaho Northern.....	106
Ketchum.....	103
Mackay.....	113
New Meadows.....	107
North Side.....	104
Oakley.....	103
Oregon Eastern.....	108
Payette.....	107
Raft River.....	102
St. Anthony.....	112
Stoddard.....	108
Teton Valley.....	114

Twin Falls.....	102
West Belt.....	112
Wilder.....	109
Yellowstone.....	111

**Oregon Division —**

Subdivision:	
First.....	118
Second.....	119
Third.....	120
Fourth.....	122
Fifth.....	124
Sixth.....	126
Spokane.....	129
Branches:	
Bend.....	131
Coeur D'Alene.....	145
Condon.....	132
Connell.....	142
Dayton.....	139
Grays Harbor.....	134
Heppner.....	132
Joseph.....	130
Moscow.....	144
Olympia.....	135
Pendleton.....	137
Pilot Rock.....	130
Pleasant Valley.....	143
Sierra Nevada.....	142
Sunnyside.....	136
Tekoa.....	140
Tucannon.....	139
Umatilla.....	131
Wallace.....	136
Wallula.....	136
Yakima.....	138
<b>Mt. Hood Railway.....</b>	<b>146</b>
<b>Yakima Valley Transportation Co.....</b>	<b>148</b>

**Special Rules**

System — All Divisions.....	226
Eastern District — All Subdivisions.....	242
<b>Nebraska Division:</b>	
Omaha-Council Bluffs Area.....	242
First Subdivision and Branches.....	243
Second Subdivision and Branches.....	245
North Platte.....	243
<b>Wyoming Division — All Subdivisions.....</b>	<b>246</b>
First Subdivision and Branches.....	247
Second Subdivision and Branches.....	249
Fourth Subdivision and Branches.....	250
<b>Kansas Division — All Subdivisions.....</b>	<b>253</b>
First Subdivision and Branches.....	253
Second Subdivision and Branches.....	254
South-Central district — All Subdivisions.....	255
<b>Utah Division:</b>	
Salt Lake City Terminal Area.....	255
Ogden Terminal Area.....	257
First Subdivision and Branches.....	257
Second Subdivision and	
Provo Subdivision and Branches.....	258
Third Subdivision and Branches.....	259
<b>California Division — All Subdivisions.....</b>	<b>263</b>
First Subdivision and	
Boulder City Branch.....	264
Second Subdivision and Branches.....	265
Northwestern District — All Subdivisions.....	269
<b>Idaho Division — All Subdivisions.....</b>	<b>269</b>
Pocatello Terminal Area.....	270
First Subdivision and Branches.....	271
Second Subdivision and Branches.....	272
Third Subdivision and Branches and Boise Cut-Off.....	273
Fourth Subdivision and Branches.....	273
<b>Oregon Division — All Subdivisions.....</b>	<b>275</b>

First and Second	
Subdivisions and Branches.....	275
Hinkle Terminal.....	276
Third and Fourth	
Subdivisions and Branches.....	277
Albina Terminal.....	278
Consolidated Code — Special Rules.....	279
Fifth Subdivision and Branches.....	279 and 283
Sixth Subdivision and Branches.....	284
Spokane International Railroad.....	284

**Appendixes — All Divisions:**

Alternate Placards.....	*13A	344
CTC Rules — Spl. Rule 268 (R).....	*6	310
Close Clearances — Spl. Rule 900 (R).....	*10	324
Crossovers and Turnouts — Spl. Rule 104 (R).....	*3	300
Detectors, hot box and dragging equipment — (locations) Spl. Rules 812 (R-1, 4, 5, & 6).....	*8	316
Handling Hazardous Materials — Spl. Rule 713 (R).....	*12	338
Position In Train Of Placarded Cars Containing Hazardous Materials.....	*14	346
Public Crossings — Spl. Rule 103 (R).....	*2	294
Railroad Crossings and Junctions — Spl. Rule 98 (R).....	*1	286
Reference Guide For Switching Placarded Cars.....	*13	342
Speed Signals — Spl. Rule 240 (R-2).....	*5	308
Switches (Handling & Normal Position) — Spl. Rule 104 (R-1).....	*4	304
Tonnage Ratings and Car Chart.....	*11	330 and 336
Track Restrictions — Spl. Rule 899 (R).....	*9	319
Use of Air Brakes (Handling Cars) — Spl. Rule 806 (R).....	*7	312
Use of Hand Brakes — Spl. Rule 806 (R-1).....	*7	313

\*Denotes Appendix

**INDEX — WESTERN DISTRICT**

**General**

Maps — Division:	
Eastern.....	153
Western.....	173
<b>Officers — District</b> .....	150
Emergency Phone Numbers.....	151
<b>Radio Procedure</b> .....	152
<b>Speed and Car Handling Restrictions — General</b> .....	154
<b>Locomotive Restrictions</b> .....	156

**Timetables and Speed Restrictions**

Eastern Division —	
Subdivision:	
Seventh.....	162
Sixth.....	166
Fifth.....	170
Branches:	
Warner.....	172
Ellerbeck.....	172
Rowley.....	172
Marblehead.....	172
Western Division —	
Subdivision:	
Fourth.....	174
Third.....	176
Second.....	178
First.....	180
Branches:	
Reno.....	182
Loyalton.....	183
Tracy.....	183
San Jose.....	184
Sacramento Northern Branches:	
Chico.....	186
Tarke.....	186
Pearson.....	186
Rio Linda.....	188
Woodland.....	188
Holland.....	188
Pittsburg.....	190
Vacaville.....	190
Dozier.....	190
Montezuma.....	190
Tidewater Southern:	
Main Track.....	192
Manteca Branch.....	192
Chemurgic Branch.....	192

**Special Instructions**

**Western District — All Subdivisions**

Eastern Division:	
Salt Lake City.....	194
Seventh Subdivision.....	195
Elko.....	195
Sixth Subdivision.....	196
Paired Track.....	196
Winnemucca.....	197
Fifth Subdivision (to but not including Flanigan).....	197
Branches.....	197
Western Division:	
Fifth Subdivision (Flanigan to Portola).....	198
Portola.....	198
Fourth Subdivision.....	198
Third Subdivision.....	199
Oroville.....	200
Second Subdivision.....	200
Stockton.....	201
First Subdivision.....	202
Oakland.....	203
Branches.....	204
Sacramento Northern.....	204
Tidewater Southern.....	206

<b>Appendix 1, Interlocking Plants and Railroad Crossings.....</b>	<b>208</b>
--	------------

Appendix 2, Public Crossings .....	214
Appendix 3, Hot Box Detectors .....	220
Appendix 4, Watch Inspectors, Safe Coupling Speed Railroad Physicians, Tunnel Locations and Yard Limits .....	222

## SPEEDS SHOWN BELOW ARE ARE MAXIMUM SPEEDS PERMITTED

**Designation "Psgr."** — Train with locomotive and all passenger train equipment.

**Designation "Frt."** — Train with freight cars; train with caboose only; locomotive without cars, other than train movement.

### GENERAL

LOCATION	MPH
Moving against the normal current of traffic on a main track, unless otherwise specified by train order.	30
When using No. 20 equilateral.	60
When using No. 20 turnout, unless a different speed is specified.	40
When using No. 14 turnout located on:	
Straight track.	30
Curves.	15
When using other turnouts.	15
Facing point movement over spring switches not protected by signals unless advised by train order that switch has been spiked.	20
Within yard limits protected by continuous block signal system, unless a different speed is specified.	35
Within yard limits not protected by continuous block signal system, unless a different speed is specified.	20
When using tracks other than main tracks, unless a different speed is specified.	15
Sidings in CTC territory, unless a different speed is specified. EXCEPTION: Speed Signal Territory	20
Balloon tracks & Wye tracks, except those portions used as main track or siding.	5
Movements of engines at servicing facilities.	5
1400, 6900, 9000 class units:	
in passenger service	82
in freight service	70
All other freight units	70
Yard switch locomotives in road service:	
1000 class.	35
1200 class.	50
1800 class.	50
Car body type unit backing up light or backing up as leading unit at front of train.	30
When multiple unit engine is controlled from other than leading unit.	30
Diesel locomotive running light, on descending grade in excess of 1 percent, when necessary to use engine brake to control speed.	25
Trains handling wrecking derricks:	
American hoist derricks 903045, 903046, 903047, 903050	60
Derricks with 6-wheel trucks.	40
Derricks with 4-wheel trucks.	35
For first five miles after leaving initial terminal with derricks not equipped with roller bearings. (all slower speeds applying to freight trains on curves and other restricted locations must be complied with)	20
Trains handling scale test cars, wedge plows, or roadway machines on their own wheels (except wrecking derricks):	
On main tracks — tangent track.	35
On main tracks — curves.	25
On branch lines.	25
Exception: Scale test cars UP 903006, WO-3, WO-4 and WO-5 may be handled at maximum freight train speed.	
Self-propelled cranes, pile drivers and similar equipment moving under own power. (Slower speed must be observed where conditions require.)	35
Holmes, Pettibone and similar type cranes, and hi-rail equipped wheel changers. (Slower speed must be observed where conditions require.)	25
Jordan spreaders and other machines of spreader type, when in operation with wings extended.	15

LOCATION	MPH
Trains handling continuous welded rail or continuous lengths of jointed rail on unrestricted track.	40
On restricted track or curves, 20 MPH LESS than published speed, except when published speed is 30 MPH or less, must not exceed 10 MPH, (see 809(R))	10
Through crossovers or turnouts.	
Trains handling diesel units dead in train:	
Yard-switch units with friction bearings	35
Yard-switch units with roller bearings (This includes all 1200 class units)	50
Trains handling tank cars containing Phosphorus (EXCEPTION See 809(R-2))	
Liquid Petroleum Gas, Propane, Anhydrous Ammonia, Chlorine.	50
Exception: Oregon 6th Subdivision-loaded propane cars	40
Coal Trains loaded or empty, when moving under tipple on any mine spur.	15
Trains handled with RCS units.	50
UP 26000-27000 series cars loaded and empty Except UP 26500-26749 and UP 27500-27554 series cars loaded and empty.	40
Trains handling ballast except when loaded in cars UP 901000 through 901599	40
Unit trains handling open-top or covered hopper cars when loaded except loaded unit phosphate rock trains	50
Trains handling logs, unless cars are staked and wired in accordance with AAR rules: Maximum speed.	20
Through truss bridges.	5
Trains handling empty gondolas or empty open-top hopper cars.	50
Trains handling cars UP 16000 through 17949, UP 60000 through 66999, UP 85000 through 91999 when loaded.	50
Trains with retaining valves in use.	20
Trains handling empty bulkhead flat cars. Exceptions: UP 25700 series cars and JTTX cars equipped with Toyota truck-bed racks.	40
Trains handling open-top loads on ordinary flat cars, loaded bulkhead flat cars or gondola cars loaded above the sides or ends of car on any train. EXCEPTION: TOFC or COFC traffic, bulkhead flats carrying Toyota auto racks and the following car series: TBCX 7471 through 7481 and TBCX 76700 through 76707.	50
Trains handling ore Except UP 26500-26749 And CFIW Trains when handling ore in open top cars	40
Trains handling rip-rap.	40

#### WYOMING DIVISION

Amtrak trains operated with SDP 40F units between: Denver — Speer	79
Except on restricted curves	40
Cheyenne — Ogden	79
Except on restricted curves — maximum freight speed on such curves	
Cheyenne — Dale on No. 3 track	55

#### UTAH DIVISION

Trains handling coiled steel between Salt Lake and Ogden to SP destinations	40
---	----

#### NORTHWESTERN DISTRICT

Freight trains averaging in excess of 75 tons per operative brake EXCEPTION: Between Granger and Albina	40
0-80 tons per operative brake	70
80-100 tons per operative brake	65
100 or more tons per operative brake	60
Helper units when running light	50

#### SOUTH CENTRAL AND NORTHWESTERN DISTRICT

Amtrak trains operated with SDP-40F units must not exceed freight train speed on all restricted curves, but must not exceed 40 MPH on any restricted curve.	
---	--

## EASTERN DISTRICT

M. E. MERRITT

General Manager

C. E. O'HARA

General Superintendent

## NEBRASKA DIVISION

### R. L. GREEN

J. E. DENNIS  
G. G. ESCALANTE  
B. H. DOXEY  
A. C. THRAEN  
T. J. RICHARDS  
D. R. HEGARTY, JR.  
L. V. HAMM  
C. E. LYNN III  
J. E. BRIDGER  
S. F. SHUDAK  
A. R. ORRICK  
R. B. BERNEY  
M. T. WILDE  
C. F. WEILAND  
A. F. DISMUKES  
R. W. COLEMAN  
W. F. GRIFFIN  
J. F. PFEIFFER  
J. M. SUNDBERG  
W. E. VANTRUMP  
C. R. EASTWOOD  
J. A. SON

### Superintendent

Division Assistant Superintendent  
Trainmaster  
Terminal Superintendent  
Assistant Terminal Superintendent  
Terminal Trainmaster  
Terminal Trainmaster  
Terminal Trainmaster  
Road Foreman-Assistant Trainmaster  
Trainmaster  
Terminal Trainmaster  
Trainmaster  
Trainmaster  
Trainmaster  
Road Foreman of Engines  
Road Foreman-Assistant Trainmaster  
Road Foreman-Assistant Trainmaster  
Manager of Safety  
Manager of Safety  
Division Engineer  
General Roadmaster  
General Roadmaster  
Manager-Operating Rules

### Council Bluffs, Ia

Council Bluffs, Ia.  
Omaha, Nebr.  
Council Bluffs, Ia.  
Council Bluffs, Ia.  
Council Bluffs, Ia.  
Council Bluffs, Ia.  
Cheyenne, Wyo.  
Columbus, Nebr.  
Fremont, Nebr.  
Grand Island, Nebr.  
North Platte, Nebr.  
Sidney, Nebr.  
Council Bluffs, Ia.  
North Platte, Nebr.  
North Platte, Nebr.  
Council Bluffs, Ia.  
North Platte, Nebr.  
Council Bluffs, Ia.  
North Platte, Nebr.  
Fremont, Nebr.

### FIRST SUBDIVISION AND BRANCHES

S. C. WALLACE

Chief Dispatcher

North Platte, Nebr.

### SECOND SUBDIVISION AND BRANCHES

D. D. BRUNS

Chief Dispatcher

North Platte, Nebr.

### Assistant Chief Dispatchers

J. W. SHAFER ..... North Platte, Nebr.  
J. M. WOERTH ..... North Platte, Nebr.  
M. L. HARDING ..... North Platte, Nebr.  
P. W. KILLION ..... North Platte, Nebr.  
M. J. O'BRIEN ..... North Platte, Nebr.  
R. L. WEISGERBER ..... North Platte, Nebr.  
R. C. FEE ..... North Platte, Nebr.

## BAILEY YARD

### G. B. RECTOR

G. F. BAKER  
H. D. WELTON  
C. D. SMITH  
P. P. LOCKE  
J. J. JOHANSON  
S. N. PERKINS  
D. L. CRAGO  
G. R. DODGE

### Superintendent

Assistant Superintendent  
Terminal Trainmaster  
Terminal Trainmaster  
Terminal Trainmaster  
Terminal Trainmaster  
Terminal Trainmaster  
Terminal Trainmaster  
Terminal Trainmaster  
Road Foreman-Assistant Trainmaster

### North Platte, Nebr.

North Platte, Nebr.  
North Platte, Nebr.  
North Platte, Nebr.  
North Platte, Nebr.  
North Platte, Nebr.  
North Platte, Nebr.  
North Platte, Nebr.  
North Platte, Nebr.

## WYOMING DIVISION

### M. L. BUTLER

G. L. KISSEL  
R. D. JONES  
W. J. KARY  
J. M. CHUBB  
J. W. McMULLEN  
E. C. BURNS  
K. W. BLAIR  
M. N. WELKER  
T. P. HENNESSY  
J. D. YOUNG  
J. M. ROBERTS  
D. R. ROMER  
K. R. McCARTY  
K. R. HAUGH  
D. P. FITZPATRICK  
C. H. ALLEN, JR.  
S. A. LEE  
D. C. HAMPTON  
R. V. DURRANT  
R. J. WHITE

### Superintendent

Division Assistant Superintendent  
Trainmaster  
Trainmaster  
Terminal Trainmaster  
Trainmaster  
Terminal Superintendent  
Assistant Terminal Superintendent  
Terminal Trainmaster  
Terminal Trainmaster  
Terminal Trainmaster  
Trainmaster  
Terminal Superintendent  
Trainmaster  
Trainmaster  
Trainmaster  
Road Foreman of Engines  
Road Foreman-Assistant Trainmaster  
Road Foreman of Engines  
Road Foreman-Assistant Trainmaster  
Road Foreman-Assistant Trainmaster  
Road Foreman-Assistant Trainmaster

### Cheyenne, Wyo.

Cheyenne, Wyo.  
Cheyenne, Wyo.  
Cheyenne, Wyo.  
LaSalle, Colo.  
Denver, Colo.  
Denver, Colo.  
Denver, Colo.  
Denver, Colo.  
Denver, Colo.  
Rawlins, Wyo.  
Green River, Wyo.  
Green River, Wyo.  
Green River, Wyo.  
Ogden, Utah  
Cheyenne, Wyo.  
Cheyenne, Wyo.  
Rawlins, Wyo.  
Green River, Wyo.  
Ogden, Utah

K. D. JACKSON  
W. E. WIMMER  
R. L. EADES  
B. L. JACKSON  
J. L. EHERNBERGER

Manager of Safety  
Division Engineer  
Assistant Division Engineer  
General Roadmaster  
Manager-Operating Rules

Cheyenne, Wyo.  
Cheyenne, Wyo.  
Cheyenne, Wyo.  
Cheyenne, Wyo.  
Cheyenne, Wyo.

J. W. FRAMPTON

**FIRST AND SECOND SUBDIVISIONS**  
Chief Dispatcher

Cheyenne, Wyo.

J. E. MASON

**THIRD AND FOURTH SUBDIVISIONS**  
Chief Dispatcher

Cheyenne, Wyo.

**Assistant Chief Dispatchers**

M. D. COSTANZO ..... Cheyenne, Wyo.  
G. J. JACOBSEN ..... Cheyenne, Wyo.  
R. J. WALKER ..... Cheyenne, Wyo.  
R. A. PENNISI ..... Cheyenne, Wyo.

**KANSAS DIVISION**

**W. A. RIDGE**

**Superintendent**

**Kansas City, Kan.**

S. R. SEARLE  
W. J. WRIGHT  
R. L. TAYLOR  
J. R. CARDEN  
R. A. HANSON  
T. C. HILL  
E. V. POTTS  
L. S. JACOBSON  
A. L. HASSLER  
G. A. WALLING  
M. S. BOWERS  
B. L. TROUTMAN  
W. M. EMERY  
D. C. GRIFFIN  
J. O. WORTHINGTON  
G. C. FRANCIS  
C. M. KELLOGG

Division Assistant Superintendent  
Terminal Superintendent  
Assistant Terminal Superintendent  
Assistant Terminal Superintendent  
Terminal Trainmaster  
Terminal Trainmaster  
Terminal Trainmaster  
Trainmaster  
Trainmaster  
Trainmaster  
Road Foreman-Assistant Trainmaster  
Road Foreman-Assistant Trainmaster  
Road Foreman-Assistant Trainmaster  
Road Foreman-Assistant Trainmaster  
Division Engineer  
General Roadmaster  
Manager of Safety  
Manager-Operating Rules

Kansas City, Kan.  
Kansas City, Kan.  
Kansas City, Kan.  
Kansas City, Kan.  
Kansas City, Kan.  
Kansas City, Kan.  
Kansas City, Kan.  
Topeka, Kan.  
Topeka, Kan.  
Marysville, Kan.  
Salina, Kan.  
Kansas City, Kan.  
Kansas City, Kan.  
Marysville, Kan.  
Kansas City, Kan.  
Kansas City, Kan.  
Kansas City, Kan.  
Kansas City, Kan.

**KANSAS CITY — GIBBON**

A. L. LANDRETH  
D. L. KIRKPATRICK  
V. E. MEINKECKE  
T. W. SPATH

Chief Train Dispatcher  
Assistant Chief Train Dispatcher  
Assistant Chief Train Dispatcher  
Assistant Chief Train Dispatcher

Kansas City, Kan.  
Kansas City, Kan.  
Kansas City, Kan.  
Kansas City, Kan.

**MENOKEN — DENVER**

M. W. BARKLEY  
C. J. WAITS

Chief Train Dispatcher  
Assistant Chief Train Dispatcher

Kansas City, Kan.  
Kansas City, Kan.

**EASTERN DISTRICT MILEAGES**

Division	Main Track	Branches	Total
Nebraska	660.6	808.3	1468.9
Wyoming	666.5	253.0	919.5
Kansas	843.0	459.4	1302.4
<b>TOTALS</b>	<b>2170.1</b>	<b>1520.7</b>	<b>3690.8</b>

**EASTERN DISTRICT  
LOCATION OF STANDARD CLOCKS  
COLORADO**

Julesburg ..... Telegraph Office  
Sterling ..... Telegraph Office  
LaSalle ..... Telegraph Office  
Denver ..... Telegraph Office  
Denver, 23rd Street ..... Engineer's Register Room  
Denver, 23rd Street ..... Switchman's Register Room  
Denver, 24th Street ..... Engineer's Register Room  
Denver, 24th Street ..... Switchman's Register Room

Denver, Union Terminal ..... Register Room  
Denver, 36th Street ..... Train and Enginemen's Register Room  
Denver, 36th Street ..... Switchman's Register Room  
Roydale ..... Register Room  
Commerce City ..... Register Room

**IOWA**

Council Bluffs ..... Dieselhouse Register Room  
Council Bluffs ..... Yard Office

**KANSAS**

Kansas City ..... Chief Dispatcher's Office  
Kansas City ..... 18th Street Tower Register Room  
Kansas City ..... Mattoon Creek Register Room  
Kansas City ..... Yard Office Train Order Room  
Armstrong ..... Train Crew Dispatcher's Office  
Armstrong ..... Telegraph Office  
Armstrong ..... Engineer's Register Room  
Armstrong ..... Mill Street Register Room  
Kaw Tower ..... Register Room  
Kaw Tower ..... Operator Office  
Fairfax ..... North Yard Office  
Fairfax ..... Quindaro Register Room  
Bonner Springs ..... Telegraph Office  
Lawrence ..... Telegraph Office  
Topeka ..... Telegraph Office  
Topeka ..... Engineer's Locker Room  
Manhattan ..... Telegraph Office  
Junction City ..... Telegraph Office  
Abilene ..... Telegraph Office  
Salina ..... Register Room, Union Station  
Salina ..... Telegraph Office, Union Station  
Salina ..... Yard Office  
Salina ..... Roundhouse  
Oakley ..... Telegraph Office  
Plainville ..... Telegraph Office  
Marysville ..... Telegraph Office  
Marysville ..... Register Room

**MISSOURI**

St. Joseph ..... Terminal Yard Office

**NEBRASKA**

Omaha ..... Tower "B"  
Omaha, 8th Street Yard ..... Enginemen's and Yardmen's Register Room  
Fremont ..... Telegraph Office  
Columbus ..... Telegraph Office  
Columbus ..... Train and Enginemen Register Room  
Grand Island ..... Telegraph Office  
Grand Island ..... Register Room  
Kearney ..... Telegraph Office  
Gothenburg ..... Telegraph Office  
Lexington ..... Telegraph Office  
North Platte ..... Chief Dispatcher's Office  
North Platte ..... Telegraph Office  
North Platte ..... Conductor's Register Room, Yard Office  
North Platte ..... Engine Dispatcher's Office  
North Platte ..... Hump Yard Locker Room  
North Platte ..... Yardmen's Locker Room  
North Platte ..... East End Yardmen's Room  
North Platte ..... North Crest Tower  
North Platte ..... IBM Office  
Sidney ..... Telegraph Office  
Kimball ..... Telegraph Office  
Gering ..... Telegraph Office  
Carleton ..... Telegraph Office  
Hastings ..... Yard Office  
Beatrice ..... Agent's Office

**UTAH**

Ogden ..... 28th Street Telegraph Office  
Ogden ..... 33rd Street Register Room

**WYOMING**

Cheyenne ..... Dispatcher's Office  
Cheyenne ..... Switchman's Register Room  
Cheyenne ..... Conductor's Register Room  
Cheyenne ..... Train and Engineer's Locker Room  
Laramie ..... Amtrak Depot  
Laramie ..... Telegraph Office  
Laramie ..... Conductor's Room  
Hanna ..... Telegraph Office  
Rawlins ..... Telegraph Office  
Rawlins ..... Conductor's Register Room  
Rawlins ..... Yard Office  
Rock Springs ..... Telegraph Office  
Rock Springs ..... Switchmen's Locker Room  
Green River ..... Telegraph Office  
Green River ..... Switchmen's Locker Room  
Green River ..... Train and Enginemen's Register Room  
Evanston ..... Telegraph Office

# SOUTH DAKOTA

WYO.

MINNESOTA  
IOWA



# NEBRASKA

IA.

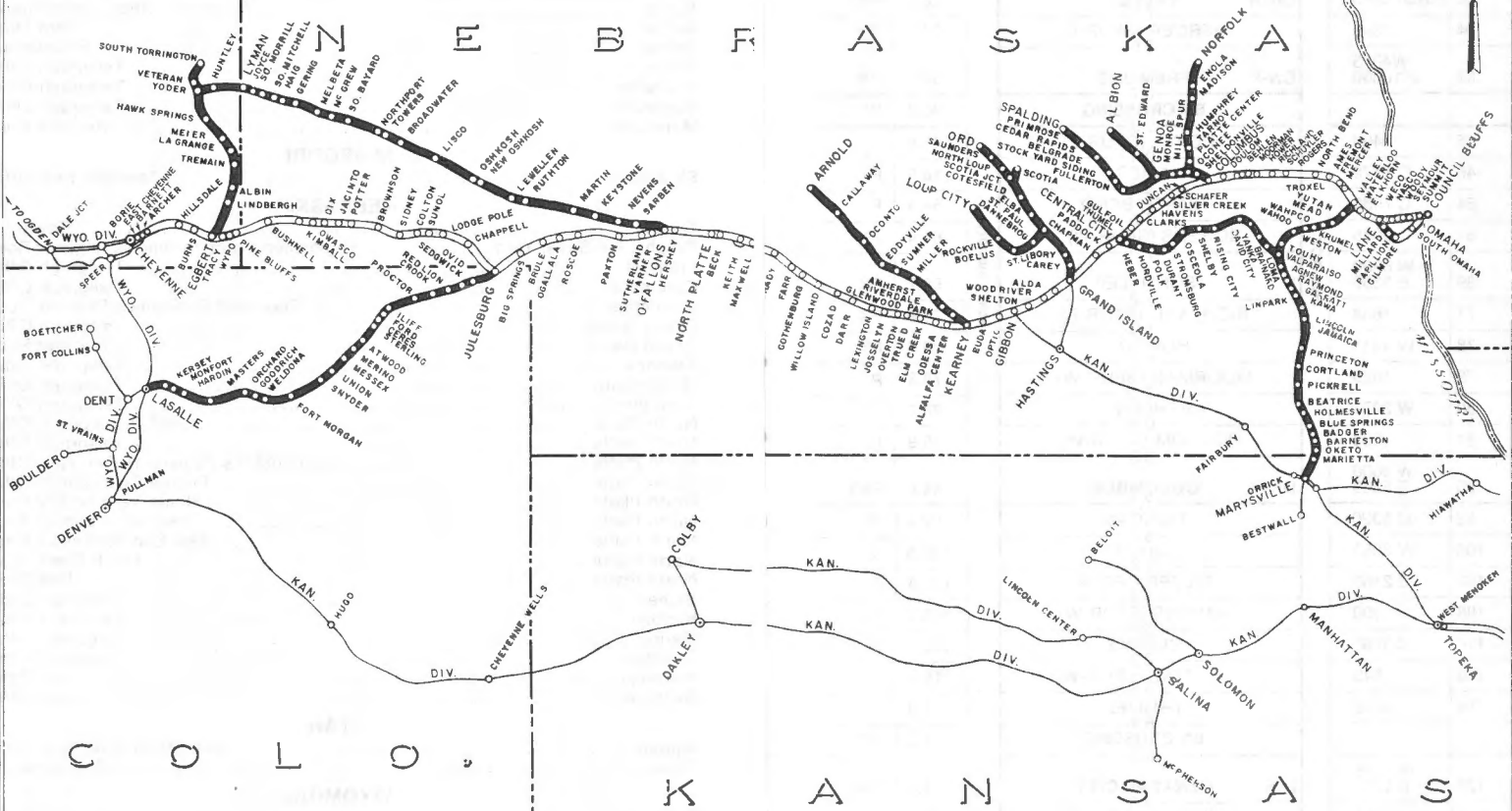

UNION PACIFIC RAILROAD  
**EASTERN DISTRICT**  
**NEBRASKA DIVISION**

SCALE OF MILES

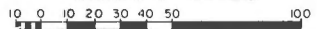

OFFICE OF CHIEF ENGINEER - OMAHA, NEBR.  
 C.E. DRAWING NO. 82727

NEBRASKA DIVISION

WESTWARD		FIRST SUBDIVISION	EASTWARD	
Station Number	LENGTH OF SIDINGS	Timetable No. 7	MILE POST	RULE 6(B)
	FEET			
0		DN-R COUNCIL BLUFFS YL	0.0	FIPX
		2.1		
		EAST END MISSOURI RIVER BR. YL	2.1	IPX
		0.3		
		* WEST END MISSOURI RIVER BR. YL	2.4	IPX
		0.7		
3		DN TOWER "B" YL	3.1	IPX
		0.8		
		20TH STREET YL	3.9	IPX
		1.3		
5		SUMMIT YL	5.2	IPX
		3.7		
9	W 2000	SEYMOUR	8.9	PX
		2.8		
12	E 11353	WOODY	11.7	PXY
		0.5		
12	1700	NASCO (SPUR-W)	12.2	X
		1.4		
13	E 8240	WECO	13.6	PX
		3.1		
17		LANE	16.7	PX
		5.0		
22	C 3400	ELKHORN	21.7	P
		2.8		
25	2050	WATERLOO (SPUR-W)	24.5	
		3.5		
28	W 7950 E3950-8850	DN-R VALLEY	28.0	PXY
		6.3		
34	1358	MERCER (SPUR-E)	34.3	PX
		5.0		
39	W4073 W10000	DN-R FREMONT	39.3	PX
		0.7		
		BN CROSSING	40.0	IP
		5.9		
45	2400	TROXEL (SPUR-E)	45.9	
		0.4		
46	C 3670	AMES	46.3	P
		8.1		
54	C 7530	NORTH BEND	54.4	P
		7.0		
61	2055	ROGERS (SPUR-W)	61.4	PX
		7.3		
69	W 6300 E 5350	D SCHUYLER	68.7	PX
		8.2		
77	1634	RICHLAND (SPUR-E)	76.9	PX
		1.9		
78	W 4211	HOWER	78.8	PX
		0.5		
79	1525	MOORMAN (SPUR-W)	79.3	P
		0.6		
80	W 2073	BEHLEN	80.0	PX
		0.9		
81	1238	DOULOM (SPUR-W)	80.9	P
		3.6		
85	W 6600 E 6300	DN-R COLUMBUS	84.5	PXY
		7.7		
92	C 5320	DUNCAN	92.2	P
		8.3		
100	W 3093	SCHAFER	100.5	X
		1.8		
102	E 2460	SILVER CREEK	102.3	P
		5.9		
108	900	HAVENS (SPUR-W)	108.2	P
		5.4		
114	C 3700	CLARKS	113.6	P
		2.3		
116	543	GULFOIL (SPUR-W)	115.9	
		2.0		
118	3646	THUMEL	117.9	
		6.4		
		BN CROSSING	124.3	AP
		0.6		
125	W 4758 E 5300	D-R CENTRAL CITY	124.9	PXY
		3.6		
129	1400	PADDOCK (SPUR-W)	128.5	
		6.6		
135	C 7400	CHAPMAN	135.1	P
		11.1		
147		DN-R GRAND ISLAND	146.2	FIPXY

\* Five main tracks between MP 0.5 and east end Missouri River Bridge.  
\* Four main tracks between 20th Street and Summit.

NEBRASKA DIVISION

WESTWARD		FIRST SUBDIVISION—CONT.	EASTWARD	
Station Number	LENGTH OF SIDINGS	Timetable No. 7	MILE POST	RULE 6(B)
	FEET			
147		DN-R GRAND ISLAND	146.2	FIPXY
		0.3		
		BN CROSSING	146.5	I
		8.0		
155	E 2166	ALDA	154.5	PXY
		7.8		
162		WOOD RIVER	162.3	PX
		7.6		
170	C 3305	SHELTON	169.9	PX
		5.4		
		CP 175 (Jct.)	175.3	PXY
		0.7		
176	E 4236	D GIBBON	176.0	P
		3.8		
180	1561	OPTIC (SPUR-E)	179.8	P
		4.5		
184	E 3227	BUDA CP184	184.3	PX
		4.8		
189	W 8543 E 5190	D-R KEARNEY	189.1	PXY
		5.0		
194	E 1960	ALFALFA CENTER	194.1	X
		4.2		
198	C 3630	ODESSA	198.3	P
		6.3		
205	C 6250	ELM CREEK	204.6	P
		4.7		
209	836	TRUED (SPUR-E)	209.3	
		4.0		
213	C 10600	OVERTON	213.9	P
		4.0		
218	E 1679	JOSSLYN	217.9	PX
		6.5		
224	W 5450 E 6014	D-R LEXINGTON	224.4	PXY
		8.1		
233	C 3750	DARR	232.5	P
		5.7		
238	C 14000	D COZAD	238.2	P
		5.0		
243	W 2830	WILLOW ISLAND	243.2	PX
		5.6		
249	W 5845 E 6000	D-R GOTHENBURG	248.8	PXY
		7.7		
256	W 10458	FARR	256.5	IP
		5.0		
262	C 3645	BRADY	261.5	P
		9.1		
271	E 2182	MAXWELL	270.6	PX
		2.4		
273	795	KEITH (SPUR-W)	273.0	P
		1.0		
		CP274	274.0	PX
		2.0		
		CP276	276.0	PX
		4.5		
281	450	BECK (SPUR-W)	280.5	
		2.9		
		CP283 YL	283.4	PX
		0.7		
284		DN-R NORTH PLATTE YL	284.1	FIPXY

(284.1)

Note 2 to Rule 99 is in effect on First Subdivision.

Yard limits are continuous from 0.0 to 5.2 and from 282.75 to 291.5

Rule 251 in effect between MP 3.45 and 5.2 on Main Tracks 3 and 4, between Summit and CP 175 and between Buda and CP 274.

Rule 261 in effect between CP 175 and Buda and between CP 274 and CP 283.

Signal 110 has vertical number plate.

Dwarf signal 285.3-2 has vertical number plate.

CLEARANCE AND REGISTER REQUIREMENTS

All westward trains must receive clearance at Council Bluffs.

Trains to or from Old Main Line need not receive clearance at Lane or Summit.

Trains to or from Kansas Division need not receive clearance at CP 175 (Jct.).

Only trains which originate or terminate at Valley, Fremont, Columbus, Central City, Grand Island, Kearney, Lexington or Gothenburg need register.

Union Pacific trains operating between Grand Island and Lincoln via BN must receive a BN clearance at Grand Island before entering upon Burlington Northern tracks, Grand Island.

In addition, trains operating between Grand Island and Lincoln via Grand Island and BN will be issued a BN clearance at North Platte which will include any train orders annulling a schedule and any slow or cautionary orders in effect at that time between Grand Island and Lincoln.

Trains operating between Lincoln and North Platte via Grand Island and UP must receive a UP clearance at Grand Island.

Trains to and from the BN at Grand Island need not register at Grand Island.

### SPEED RESTRICTIONS — FIRST SUBDIVISION

LOCATION	MPH
Maximum Speed	
Between Summit and North Platte	<b>70</b>
All tracks except main tracks	<b>15</b>
Lite Engines operating between Co. Bluffs/Omaha and Fremont.	
Westward — 60 mph	
Exception: Lite engines for trains WSOAT, WSLAT, WSLAV — Maximum Speed.	
Eastward — 60 mph (unless otherwise instructed by dispatcher)	
This includes those handling cars for Omaha/Co. Bluffs.	
Council Bluffs — Omaha	
Main Tracks 1 & 2	
Between 21st Street and MP 0.5	<b>15</b>
MP 0.5 and MP 2.4 west end Missouri River Bridge	<b>25</b>
MP 2.4 west end Missouri River Bridge and Summit	<b>40</b>
Main Tracks 3, 4 & 5, Council Bluffs	<b>15</b>
Main Tracks 3 & 4, Omaha	<b>25</b>
Running Tracks 7 & 8	<b>20</b>
Between Mile Posts —	
Summit	
<b>5.8 and 6.8</b>	<b>50</b>
Weco	
<b>14.1 and 14.7</b>	<b>60</b>
<b>15.9 and 16.2</b>	<b>60</b>
Lane	
<b>18.1 and 19.8</b>	<b>60</b>
Elkhorn	
<b>21.9 and 22.1</b>	<b>60</b>
<b>22.2 and 22.6</b>	<b>50</b>
<b>22.8 and 23.2</b>	<b>60</b>
Waterloo within city limits	
<b>24.0 and 24.8</b>	<b>55</b>
Fremont, within city limits (Between MP 38.5 and MP 40.7)	<b>25</b>
Old Passing Track	<b>5</b>
Trains departing CNW Yard on Main Track and South 1 Track	<b>15</b>
Other movements in CNW Yard	<b>5</b>
Schuyler, (between MP 68.7 and MP 69.2)	<b>50</b>
Columbus	
<b>83.8 and 85.0</b>	<b>35</b>
Columbus yard tracks	<b>10</b>
Central City	
<b>124.3</b>	
At semi-automatic interlocking BN crossing between interlocking signals	<b>45</b>
Grand Island	
<b>144.0 and 145.8</b>	<b>60</b>
<b>145.8 and 147.1</b>	<b>35</b>
<b>147.1 and 149.3</b>	<b>50</b>
Grand Island, freight trains moving on yard tracks, except yard track No. 1, all movements on East Yard Runaround, Scale Track, and through turnouts and sharp curves on leads to Diesel Servicing and MofW trackage just east of BN crossing.	<b>5</b>
When entering or leaving BN Transfer.	<b>10</b>
Yard track No. 1	<b>15</b>
Alda, wye trackage, both in and outside ordinance plant	<b>5</b>
All other Ordinance trackage except main tracks	<b>5</b>
Ordinance main tracks	<b>10</b>
Buda, all airfield trackage.	<b>10</b>
<b>187.75 and 189.75*Note</b>	
Westward — until engine passes MP 189.75, provided rear of train has passed MP 189.10	
Eastward — until engine passes MP 187.75, provided rear of train has passed MP 188.90	<b>45</b>
Lexington	
Main Street to 1500 feet east on Scale Track	<b>10</b>
On 3rd and 4th tracks north, east of depot	<b>5</b>
Cozad, on Armour & Co. spur tracks.	<b>5</b>

\*NOTE—Referring to Rule 12 (D), eastward resume speed sign located to right of eastward siding at Kearney.

LOCATION	MPH
Gothenburg, Note **	
<b>248.2 and 249.3</b>	<b>60</b>
<b>258.1 and 258.3</b>	<b>65</b>
Beck	
<b>281.1 and 281.9</b>	<b>55</b>
<b>282.5 and 283.8</b>	<b>45</b>
North Platte	
<b>283.2 and 291.5</b>	<b>40</b>

\*\*NOTE—Referring to Rule 12(D), westward reduce speed sign located to the north of westward siding. Westward resume speed sign located to the north of storage track.

NEBRASKA DIVISION

WESTWARD		SECOND SUBDIVISION	EASTWARD	
STATION NUMBER	LENGTH OF SIDINGS	Timetable No. 7	MILE POST	RULE 6(B)
	FEET			
284		DN-R NORTH PLATTE YL	284.1	FIPXY
		5.4		
		MP289.5 YL	289.5	PX
		1.5		
		CP291 YL	291.0	PX
		5.9		
297	N 3388	HERSHEY	296.9	PX
		0.8		
		CP298	297.7	PX
		3.0		
301	N 10600	O'FALLONS CP 300	300.7	PXY
		1.1		
302	2489	VARNER (SPUR-W)	301.8	
		1.6		
303	X 5440	SUTHERLAND	303.4	PX
		8.1		
		CP312	311.5	PX
		4.0		
316	N 1200 S 580	PAXTON (SPUR-W)	315.5	P
		7.0		
		CP322	322.5	PX
		5.2		
328	S 665 N 715	ROSCOE	327.7	P
		7.1		
335	N 11600 S 7079	OGALLALA	334.8	PX
		9.1		
344	S2530 N 545	BRULE	343.9	P
		5.8		
		CP350	349.7	PX
		4.2		
354	X 6008	BIG SPRINGS	353.9	PX
		9.1		
		CP363	363.0	PX
		2.3		
365	N 9500 S 9500	D-R JULESBURG	365.3	PXY
		12.2		
		CP378	377.5	PX
		2.8		
380	X 5583	CHAPPELL	380.3	PX
		9.4		
390	1693	LODGE POLE (SPUR-E)	389.7	P
		2.3		
		CP392	392.0	PX
		4.3		
396	N 1284	SUNOL	396.3	P
		4.7		
401	S 1435	COLTON	401.0	P
		6.8		
408	N 12280 S 12280	D-R SIDNEY	407.8	PXY
		7.7		
416	C 4169	BROWNSON	415.5	PY
		8.4		
		CP424	423.9	PX
		2.5		
426	N 5842	POTTER	426.4	P
		4.4		
431	657	JACINTO (SPUR-E)	430.8	
		4.6		
435	1738	DIX	435.4	P
		1.8		
		CP437	437.2	PX
		1.2		
440	N 9550	OWASCO	438.4	P
		6.1		
445	C6324	D-R KIMBALL	444.5	P
		4.0		
		CP449	448.5	PX
		8.1		
457	X 5983	BUSHNELL	456.6	PX
		2.9		
		CP459	459.5	PX
		7.3		
467	E 936 W 450	PINE BLUFFS (SPUR E-W)	466.7	P
		2.8		
		CP469	469.5	PX
		0.7		
470	590	WYPO (SPUR-W)	470.2	
		1.8		
472	698	TRACY (SPUR-E)	472.0	
		5.5		
478	N 10550 897	EGBERT (SPUR-E) CP 475 CP 478	475.4 477.5	PY
		3.2		
		CP481	480.8	PX
		2.5		
483	S 3080	BURNS	483.2	P
		6.5		
490	S 1544 N 284	HILLSDALE (SPUR-E)	489.7	P
		1.3		
		CP491	491.0	PX
		10.2		

NEBRASKA DIVISION

WESTWARD		SECOND SUBDIVISION CONT.	EASTWARD	
STATION NUMBER	LENGTH OF SIDINGS	Timetable No. 7	MILE POST	RULE 6(B)
	FEET			
501	S 5956	ARCHER CP 501	501.2	PX
		5.1		
506		BARNETT YL*	506.3	PX
		2.0		
		CP 508 YL	508.3	PX
		1.2		
510		DN-R CHEYENNE YL**	509.5	FPTXY
		(225.4)		

Yard limits are continuous from 282.75 to 291.5 and from 506.25 to 511.81.

South running track between CP 291 and CP 298.

\*Three main tracks between Barnett and CP 508.

\*\*Four main tracks between CP 508 and Cheyenne.

Note 2 to Rule 99 is in effect on Second Subdivision.

Rule 261 in effect between CP 291 and Cheyenne.

Westward trains enroute Third Subdivision must identify opposing trains between North Platte and Julesburg.

CLEARANCE AND REGISTER REQUIREMENTS

Trains from North Platte Branch will retain their identity on Second Subdivision and need not receive clearance at O'Fallons CP 300.

Trains from North Platte Cut-Off will retain their identity on Second Subdivision and need not receive clearance at Egbert.

Only trains which originate or terminate at Julesburg, Sidney or Kimball need register.

Trains to or from Third Subdivision need not receive clearance at Julesburg.

SPEED RESTRICTIONS — SECOND SUBDIVISION

LOCATION	MPH
Maximum speed	70
Big Springs, over highway crossing when using siding	5
Brownson, on warehousing industrial area tracks.	
Straight track.	10
Curves	5
Hillsdale, on industry track.	5
Between Mile Posts —	
North Platte	
283.2 AND 291.5	40
South Running Track (CP 291 to CP 298)	40
Paxton	
323.5 and 324.4	60
407.5 Sidney, until engine passes 10th Ave. Crossing	60
Brownson	
422.6 and 423.5	60
Bushnell	
456.9 and 457.2	65
462.8 and 463.0	65
466.5 Pine Bluffs, until engine passes Main Street Crossing.	60
Burns	
486.2 and 486.5	60
Hillsdale	
493.7 and 494.0	60
497.7 and 498.2	60
Archer	
502.2 and 503.0	50
Cheyenne	
509.1 and 510.5 until engine passes these locations	20
Reduce speed signs located north side No. 1 track and south side No. 4 track also apply to tracks 2 and 3.	

## NEBRASKA DIVISION

WESTWARD		THIRD SUBDIVISION	EASTWARD	
STATION NUMBER	LENGTH OF SIDINGS	Timetable No. 7 STATIONS	MILE POST	RULE 6(B)
	FEET			
365	4476	D-R JULESBURG YL	0.0	PY
19-372	3412	7.1 OVID	7.1	
19-380	3602	7.5 SEDGWICK	14.6	
19-388	4254	8.5 RED LION	23.1	
19-395	1550	7.0 CROOK	30.1	
19-404	2816	8.7 PROCTOR	38.8	
19-411	1400	6.8 ILIFF	45.6	
19-415	625	4.5 FORD	50.1	
19-420	2000	4.4 CERES	54.5	
		2.9 BN CROSSING YL	57.4	P
19-423	8277	0.1 DN-R STERLING YL	57.5	P
19-429	2355	6.6 ATWOOD (SPUR-W)	64.1	
19-436	1428	6.1 MERINO (SPUR-W)	70.2	
19-441	6910	5.8 MESSEX	76.0	P*
19-446	565	4.6 UNION	80.6	P**
19-452	4599	6.4 SNYDER	87.0	
19-464	4825	11.6 FT. MORGAN	98.6	P***
19-474	3809	10.4 WELDONA	109.0	
19-480	1162	5.2 GOODRICH	114.2	
19-483	3797	3.5 ORCHARD	117.7	
19-490	950	7.1 MASTERS	124.8	
19-501	5800	10.6 HARDIN	135.4	
19-506	380	4.9 MONFORT	140.3	
19-508	3554	2.8 KERSEY	143.1	
14-687	2723	8.0 DN-R LASALLE YL	151.1	FPY
		(151.1)		

Note 2 to Rule 99 is in effect on Third Subdivision.

Yard limits are continuous from 56.12 to 59.12.

\*Bell System Auto Dialer to train dispatcher

\*\*Radio Phone

\*\*\*Dial Phone

### CLEARANCE AND REGISTER REQUIREMENTS

All trains must receive clearance at Sterling.

Only trains which originate or terminate at Julesburg or Sterling need register.

Eastward BN trains having received UP clearance at Brush need not receive clearance at Union.

Trains to or from Second Subdivision need not receive clearance at Julesburg.

### SPEED RESTRICTIONS — THIRD SUBDIVISION

LOCATION	MPH
Maximum speed.	80
Ovid Sugar Company Yard	5
LaSalle Yard Between MP 150.7 and 151.1	20

## NEBRASKA DIVISION — First Subdivision Branches

WESTWARD		OLD MAIN LINE	EASTWARD	
Station Number	LENGTH OF SIDINGS	Timetable No. 7 STATIONS	MILE POST	RULE 6(B)
	FEET			
5		SUMMIT YL	5.2	IPX
100-06		1.2 SOUTH OMAHA YL	6.4	PX
		4.7 GILMORE JUNCTION YL	10.9	IP
100-12	3600	1.4 GILMORE YL	12.3	
100-17	3250	4.5 PAILLION YL	16.8	
		2.4 MOPAC CROSSING YL	19.2	A
100-23	2911	3.3 MILLARD YL	22.5	
17		3.6 LANE YL	26.1	PX
		(20.9)		

Yard Limits are continuous from Summit to Lane.

Rule 251 is in effect between Summit and Gilmore Junction.

WESTWARD		NORFOLK BRANCH	EASTWARD	
STATION NUMBER	LENGTH OF SIDINGS	Timetable No. 7 STATIONS	MILE POST	RULE 6(B)
	FEET			
85		DN-R COLUMBUS YL	0.0	FPY
103-04	1105	4.2 SHELDONVILLE	4.2	
103-09	400	R OCONEE YL	9.4	Y
103-15	1057	5.3 PLATTE CENTER	14.7	
103-20	1456	5.6 TARNOV	20.3	
103-26	2537	5.4 HUMPHREY	25.7	
103-35	1534	9.7 MADISON	35.4	
103-41	4760	5.5 ENOLA	40.9	
		7.8 CNW CROSSING YL	48.7	A
		1.5 CNW CROSSING YL	50.2	
103-50		0.6 D-R NORFOLK YL	49.3	Y
		(49.3)		

Yard limits are continuous from 47.5 to 49.3.

WESTWARD		ALBION BRANCH	EASTWARD	
STATION NUMBER	LENGTH OF SIDINGS	Timetable No. 7 STATIONS	MILE POST	RULE 6(B)
	FEET			
103-09	1009	R OCONEE YL	0.0	Y
104-02	430	2.0 MILL SPUR (SPUR-E)	2.0	
104-04	2243	2.0 MONROE	4.0	
104-11	1640	7.3 GENOA	11.3	Y
104-22	2169	11.0 ST. EDWARD	22.3	
104-34	1207	R 11.4 ALBION	33.7	Y
		(34.7)		

### CLEARANCE REQUIREMENTS

Westward trains via Old Main Line must receive clearance at Council Bluffs and not receive clearance at Summit.

Eastward trains via Old Main Line need not receive clearance at Lane.

Trains to or from Albion Branch will retain their identity and need not receive clearance at Oconee.

### SPEED RESTRICTIONS

LOCATION — OLD MAIN LINE	MPH
Maximum speed.	25
All tracks except main tracks.	15
MP 19.2, MoPac Crossing, between home signals of automatic interlocking.	20

**SPEED RESTRICTIONS (CONT.)**

LOCATION	MPH	LOCATION	MPH
<b>Norfolk Branch</b> Maximum speed.	<b>40</b>	<b>37.2 and 37.4</b>	<b>35</b>
All tracks other than main tracks	<b>5</b>	<b>Ablion Branch</b> Maximum speed	<b>40</b>
Between Mile Posts — <b>0.0 and 1.0</b>	<b>5</b>	All tracks other than main tracks	<b>5</b>
<b>25.4 and 25.6</b>	<b>35</b>	<b>11.0 and 12.1</b> (until engine passes last road crossing)	<b>25</b>
<b>29.8 and 30.6</b>	<b>35</b>	<b>22.2 and 23.0</b> (until engine passes last road crossing)	<b>25</b>
<b>34.0 and 34.3</b>	<b>35</b>		
<b>36.3 and 36.4</b>	<b>35</b>		

**NEBRASKA DIVISION — First Subdivision Branches**

WESTWARD		CEDAR RAPIDS BRANCH		EASTWARD	
STATION NUMBER	LENGTH OF SIDINGS	Timetable No. 7		MILE POST	RULE 6(B)
	FEET	STATIONS			
104-11	1640	R	<b>GENOA</b> 13.7	0.0	Y
105-14	1604		<b>FULLERTON</b> 8.5	13.7	
105-22	585		<b>STOCKYARD SIDING</b> 0.9	22.2	
105-23	792		<b>BELGRADE (SPUR-W)</b> 7.2	23.1	
105-30	1052		<b>CEDAR RAPIDS</b> 6.3	30.3	
105-37	1645		<b>PRIMROSE</b> 7.7	36.6	
105-44	1955		<b>SPALDING</b> (44.6)	44.3	Y

WESTWARD		ORD BRANCH		EASTWARD	
STATION NUMBER	LENGTH OF SIDINGS	Timetable No. 7		MILE POST	RULE 6(B)
	FEET	STATIONS			
147		DN-R	<b>GRAND ISLAND YL</b> 0.4	0.0	FPXY
			<b>BN CROSSING YL</b> 2.1	0.4	I
106-03	634		<b>CAREY YL</b> 8.6	2.5	
106-11	1130		<b>ST. LIBORY</b> 10.8	11.1	
106-22	1348		<b>ST. PAUL</b> 8.8	21.9	Y
106-31	1416		<b>ELBA</b> 6.1	30.7	
106-37	1271		<b>COTESFIELD</b> 7.7	36.8	
106-45			<b>SCOTIA JUNCTION (SPUR-W)</b> 1.2	44.5	
106-46	714		<b>SCOTIA</b> 4.3	45.7	
106-45			<b>SCOTIA JUNCTION (SPUR-W)</b> 4.3	44.5	
106-49	1311		<b>NORTH LOUP</b> 9.7	48.8	
106-58	550		<b>SAUNDERS (SPUR-E)</b> 2.2	58.5	
			<b>BN CROSSING</b> 0.3	60.7	
106-61	1311		<b>ORD</b> (61.3)	61.0	Y

Yard Limits are continuous 0.0 to MP 3.8.

WESTWARD		LOUP CITY BRANCH		EASTWARD	
STATION NUMBER	LENGTH OF SIDINGS	Timetable No. 7		MILE POST	RULE 6(B)
	FEET	STATIONS			
106-22	1348		<b>ST. PAUL</b> 8.3	0.0	Y
107-08	W 778 E 440		<b>DANNEBROG (SPUR-W-E)</b> 10.3	8.3	
107-19	1431		<b>BOELUS</b> 7.2	18.6	
107-26	1406		<b>ROCKVILLE</b> 13.2	25.8	
107-39	1487		<b>LOUP CITY</b> (39.6)	39.0	Y

**NEBRASKA DIVISION — First Subdivision Branches**

WESTWARD		KEARNEY BRANCH		EASTWARD	
STATION NUMBER	LENGTH OF SIDINGS	Timetable No. 7		MILE POST	RULE 6(B)
	FEET	STATIONS			
189		D-R	<b>KEARNEY YL</b> 5.5	0.0	PY
11-006	700		<b>GLENWOOD PARK (SPUR-E)</b> 4.6	5.5	
11-010	1583		<b>RIVERDALE</b> 6.8	10.0	
11-017	1074		<b>AMHERST</b> 9.5	16.8	
11-026	1428		<b>MILLER</b> 6.2	26.3	
11-033	1661		<b>SUMNER</b> 7.9	32.5	
11-040	W 1210 E 350		<b>EDDYVILLE (SPUR-W-E)</b> 11.7	40.4	
11-052	1867		<b>OCONTO</b> 13.4	52.1	
11-066	1168	D	<b>CALLAWAY</b> 17.6	65.5	
11-083	1951		<b>ARNOLD</b> (83.1)	83.1	

**CLEARANCE REQUIREMENTS**

Trains to or from Cedar Rapids Branch will retain their identity and need not receive clearance at Genoa.

**SPEED RESTRICTIONS**

LOCATION	MPH
<b>Cedar Rapids Branch</b> Maximum speed.	<b>40</b>
0.00 and 1.0	<b>25</b>
All tracks other than main tracks	<b>5</b>
<b>Ord Branch</b> Maximum speed	<b>40</b>
<b>Carey Airport Trackage</b>	<b>10</b>
<b>17.7 and 18.2</b>	<b>25</b>
<b>22.2 and 61.0</b>	<b>25</b>
<b>Loup City Branch</b> Maximum speed	<b>20</b>
<b>Kearney Branch</b> Maximum speed	<b>25</b>

**NEBRASKA DIVISION — First Subdivision Branches**

WESTWARD		BEATRICE BRANCH		EASTWARD	
STATION NUMBER	LENGTH OF SIDINGS	Timetable No. 7		MILE POST	RULE 6(B)
	FEET	STATIONS			
28		DN-R	VALLEY YL	0.0	FPY
			5.8 BN CROSSING	5.8	A
50-006	842		0.5 YUTAN (SPUR-E)	6.3	
50-012	4247		5.3 MEAD	11.6	
50-015	866		3.1 WAHPCO (SPUR-W)	14.7	
50-017	620		2.7 KRUMEL (SPUR-E)	17.4	
50-019	1255		1.5 WAHOO	18.9	
			0.7 BN CROSSING	19.6	
50-026	3397		6.7 WESTON	26.3	
50-033	1692		6.9 TOUHY	33.2	
50-037	4453	R	4.1 VALPARAISO	37.3	PY
50-042	1101		4.5 AGNEW	41.8	
50-047	1474		4.7 RAYMOND	46.5	
50-048	5313		1.3 GARRATT	47.8	
50-052			4.4 KAWA (SPUR-W)	52.2	
50-054			2.5 LINPARK YL (SPUR-W)	54.7	
			0.8 B.N. JCT. YL	55.5	I*
			1.0 BN CROSSING YL	56.5	I*
50-057	1100	DN-R	0.6 LINCOLN YL	57.1	P
			0.3 BN CROSSING YL	57.4	I**
			1.6 BN CROSSING	59.0	I**
50-065	5821		6.4 JAMAICA	65.4	
50-075	945		9.3 PRINCETON	74.7	
50-080	1900		4.8 CORTLAND	79.5	
50-089	3657		9.4 PICKRELL	88.9	
50-097	4320	D	7.9 BEATRICE YL	96.8	P
50-106	1221		8.9 HOLMESVILLE (SPUR-W)	105.7	
50-110	1121		4.6 BLUE SPRINGS	110.3	
			2.8 BN CROSSING	113.1	A
50-114	5343		1.2 BADGER	114.3	
50-118	758		3.7 BARNESTON	118.0	
50-124	854		6.4 OKETO	124.4	
50-126	1394		1.5 MARIETTA	125.9	
17-148		DN-R	8.3 MARYSVILLE YL	134.2	FPT
			(134.2)		

Yard limits are continuous MP 54.5 to MP 58.9.

At Lincoln, trains and engines are governed by Operating Rules, Timetable and Special Instructions of BN while using their tracks.

\*Baird Tower via UP Radio

\*\*Hall Tower via UP Radio

**REGISTER REQUIREMENTS**

Only trains which originate or terminate at Valparaiso or Lincoln need register.

**SPEED RESTRICTIONS — BEATRICE BRANCH**

LOCATION	MPH
Maximum speed.	40
Between Mile Posts — Valley	
0.1 and 0.32	15
3.8 and 4.0	35
5.8 BN Crossing until engine passes opposing home signal of automatic interlocking	20
Yutan	
6.4 and 7.7*Note	25

**SPEED RESTRICTIONS BEATRICE BRANCH (CONT.)**

LOCATION	MPH
Wahoo, city track. 19.1 and 19.5	6 30
Weston 28.8 and 36.3	35
Touhy 36.3 and 37.4	25
Between Mile Posts — Lincoln	
55.4 and 56.5	20
56.9 and 57.5	15
57.2 Until engine passes between west scale track and east house track switch	5
59.0 BN Crossing through interlocking limits.	25
65.4 Jamaica Siding	5
Beatrice 96.5 and 97.3 **Note	15
Beatrice, Allers Grain Company spur and Kilpatrick track.	5
98.8 and 101.4	25
105.7 Holmesville Elevator Spur	5
107.2 and 112.6	30
110.3 Blue Springs siding	5
113.1 BN Crossing until engine passes opposing home signal of automatic interlocking	20
Marysville — Entering and using yard tracks. Before westward train passes MP 132.25, member of crew must communicate with yardmaster and be governed by his instructions.	10

Note — Referring to Rule 12 (D)

\*Eastward Reduce Speed Sign at MP 6.4 located on left side of track.

\*\*Eastward Resume Speed Sign at MP 96.5 located on left side of track.

WESTWARD		STROMSBURG BRANCH		EASTWARD	
STATION NUMBER	LENGTH OF SIDINGS	Timetable No. 7		MILE POST	RULE 6(B)
	FEET	STATIONS			
50-037		R	VALPARAISO YL	0.0	PY
102-07	804		7.4 LOMA	7.4	
102-14	967		6.1 BRAINARD	13.5	
102-22	3300		8.3 YANKA	21.8	
102-23	1156		1.4 DAVID CITY	23.2	
			0.3 BN CROSSING	23.5	
102-33	1355		9.8 RISING CITY	33.3	
102-40	1507		6.8 SHELBY	40.1	
102-48	656		7.4 OSCEOLA	47.5	
102-53	1200		5.4 STROMSBURG	52.9	
102-57	1079		3.9 DURANT	56.8	
102-63	2497		6.2 POLK	63.0	
102-69	900		5.5 HORDVILLE	68.5	
102-74	972		5.3 HEBER YL	73.8	
			1.5 BN CROSSING YL	75.3	AP
125		D-R	0.6 CENTRAL CITY YL	75.9	PY
			(75.9)		

Yard limits are continuous from 73.55 to end of branch.

## SPEED RESTRICTIONS — STROMSBURG BRANCH

LOCATION	MPH
Maximum speed.	40
On tracks other than main tracks	5
Between Mile Posts — Valparaiso	MPH
1.25 and 6.4	30
6.4 and 8.0	25
8.1 and 11.0	30
Brainard 13.5 until engine passes public crossings.	25
David City	20
23.0 and 23.5	20

## NEBRASKA DIVISION — Second Subdivision Branches

WESTWARD		NORTH PLATTE BRANCH		EASTWARD	
STATION NUMBER	LENGTH OF SIDINGS	STATIONS	MILE POST	RULE 6(B)	
	FEET				
301		O'FALLONS YL	0.0	PXY	
12-013	1881	<sup>12.8</sup> SARBEN	12.8		
12-019	6664	<sup>6.6</sup> NEVENS	19.4		
12-028	2486	<sup>9.0</sup> KEYSTONE	28.4	P	
12-035	2475	<sup>6.5</sup> MARTIN	34.9		
12-052	516	<sup>16.8</sup> RUTHTON (SPUR-W)	51.7		
12-059	3451	<sup>7.6</sup> LEWELLEN	59.3		
12-068	6664	<sup>8.5</sup> NEW OSHKOSH	67.8		
12-071	2025	<sup>3.0</sup> OSHKOSH	70.8	P	
12-086	1750	<sup>15.6</sup> LISCO	86.4		
12-100	1939	<sup>14.0</sup> BROADWATER	100.4	P	
12-110	1337	<sup>9.2</sup> TOWERS	109.6		
12-114	8000	<sup>4.5</sup> NORTHPORT YL	114.1	P	
12-115		<sup>1.4</sup> BN CROSSING	115.5	AP*	
12-127	789	<sup>11.2</sup> SOUTH BAYARD	126.7		
12-132	2148	<sup>5.4</sup> MCGREW	132.1		
12-128	1403	<sup>5.8</sup> MELBETA	137.9		
12-146	3132	<sup>8.0</sup> DN-R GERING YL	145.9	FPTY	
12-152	1430	<sup>6.4</sup> HAIG	152.3		
12-156	1484	<sup>3.5</sup> SOUTH MITCHELL	155.8		
12-162	2136	<sup>6.3</sup> SOUTH MORRILL	162.1		
12-164		<sup>2.1</sup> JOYCE	164.2		
12-168	2464	<sup>3.7</sup> LYMAN	167.9	Y	
12-174	630	<sup>6.0</sup> HUNTLEY (SPUR-W)	173.9		
12-182	2250	<sup>7.7</sup> R YODER YL	181.6	Y	
12-188	2348	<sup>6.5</sup> VETERAN	188.1		
12-201	2491	<sup>12.5</sup> D-R SO. TORRINGTON YL	200.6	Y	
		(200.6)			

## CLEARANCE REQUIREMENTS

At O'Fallons, trains to or from North Platte Branch will retain their identity and need not receive clearance at O'Fallons.

\*BN Dispatcher Phone

## SPEED RESTRICTIONS — NORTH PLATTE BRANCH

LOCATION	MPH
Maximum speed.	40
Between Mile Posts —	
115.5 BN crossing between home signals of interlocking.	20
Gering, until engine passes 10th St. Crossing (MP 146.0)	10
Between Mile Posts —	
147.0 and 147.5	35
Yoder	
183.5 and 184.0	30
187.1 and 189.0	30
190.7 and 192.1	35
197.1 and 198.3	25
South Torrington, over Main Street Crossing	10

## NEBRASKA DIVISION — Second Subdivision Branches

WESTWARD		NORTH PLATTE CUT-OFF		EASTWARD	
STATION NUMBER	LENGTH OF SIDINGS	STATIONS	MILE POST	RULE 6(B)	
	FEET				
12-182	2250	R YODER YL	62.7	Y	
114-52	2310	<sup>10.8</sup> HAWK SPRINGS	51.6	P	
114-43	1083	<sup>8.3</sup> MEIER	43.3		
114-41	2354	<sup>2.8</sup> LA GRANGE	40.5	P	
114-34	485	<sup>7.0</sup> TREMAIN (SPUR-E)	33.5		
114-22	2553	<sup>12.0</sup> ALBIN	21.5	P	
114-15	1668	<sup>6.9</sup> LINDBERGH	14.6		
478		<sup>14.6</sup> EGBERT YL	0.0	PY	
		(62.7)			

## CLEARANCE REQUIREMENTS

At Egbert, trains to or from North Platte Cut-Off will retain their identity and need not receive clearance.

## SPEED RESTRICTIONS

LOCATION	MPH
North Platte Cut-off	
Maximum speed.	40
Between Mile Posts —	
Egbert	
5.6 and 6.0	30
9.1 and 11.75	30
Lindbergh	
18.0 and 18.25	30
20.81 and 21.01	30
Albin	
23.7 and 33.22	25
27.0 and 27.2 Through tunnel between Albin & Tremain	20
38.3 and 38.6	30
LaGrange	
46.5 and 47.5	30
50.5 and 51.0	30

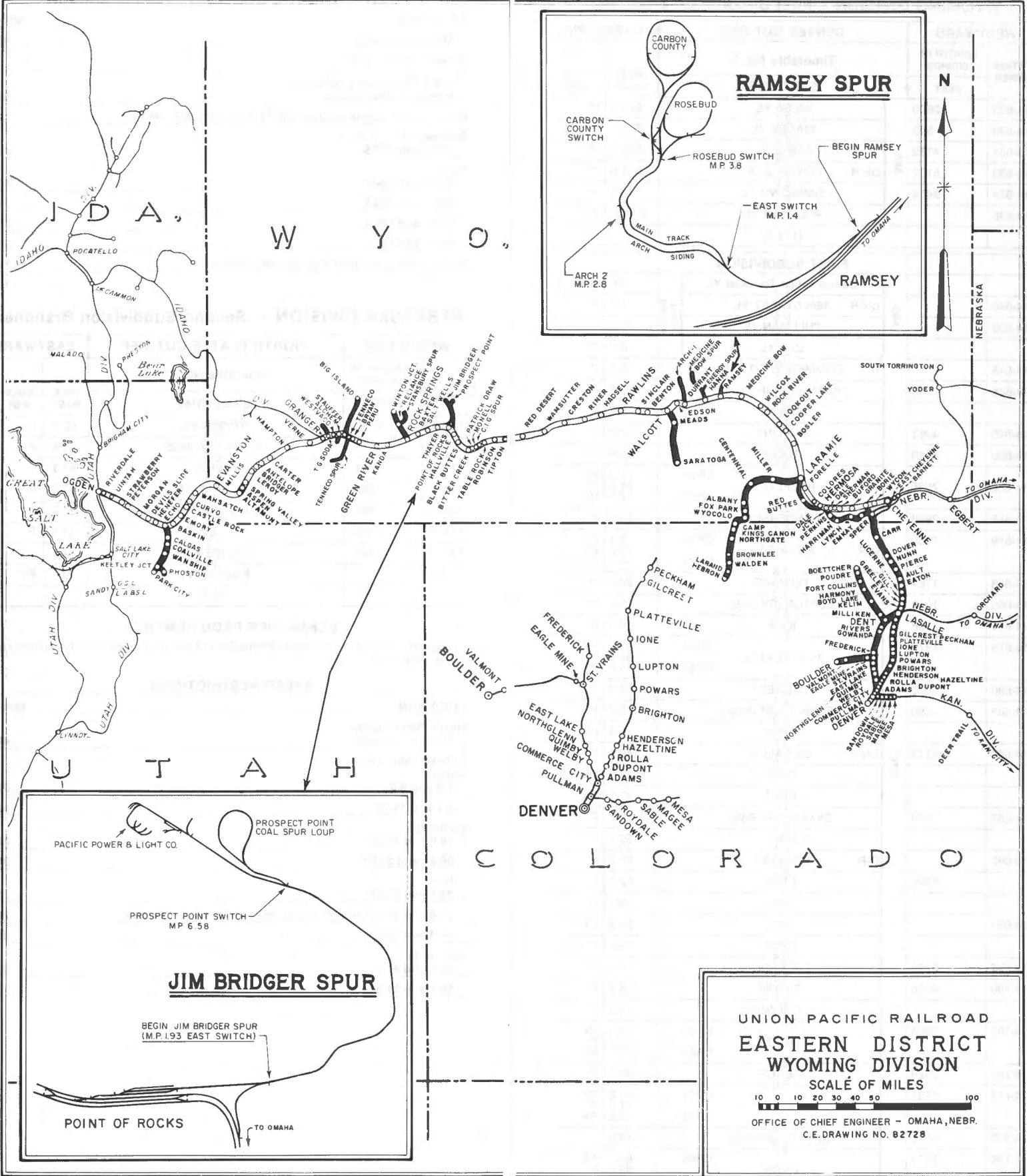

**RAMSEY SPUR**

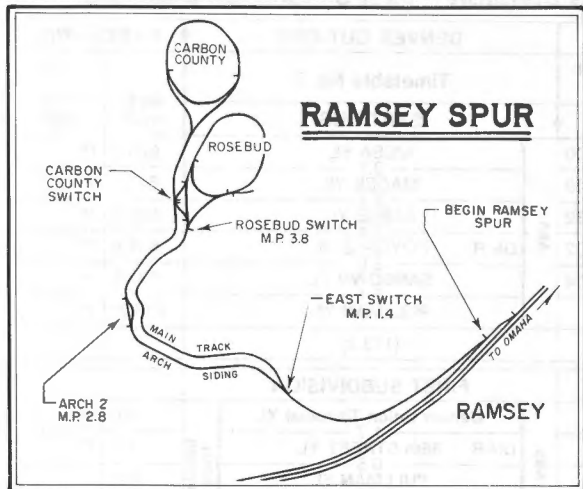

**JIM BRIDGER SPUR**

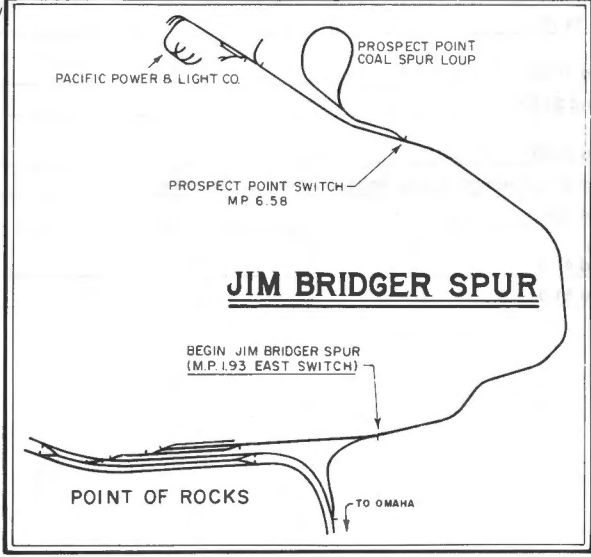

**UNION PACIFIC RAILROAD  
EASTERN DISTRICT  
WYOMING DIVISION**

SCALE OF MILES  
0 10 20 30 40 50 100

OFFICE OF CHIEF ENGINEER - OMAHA, NEBR.  
C.E. DRAWING NO. 62728

WYOMING DIVISION - First Subdivision Branches

WESTWARD		DENVER CUT-OFF		EASTWARD	
STATION NUMBER	LENGTH OF SIDINGS	Timetable No. 7		MILE POST	RULE 6(B)
	FEET	STATIONS			
14-625	2600	MESA YL	3.1	625.0	P
14-628	599	MAGEE YL	2.4	628.1	P
14-631	4132	SABLE YL	2.4	630.5	P
14-633	5102	DN-R ROYDALE YL	2.6	631.9	PY
14-634	3454	SANDOWN YL	3.1	634.5	P
14-638		PULLMAN YL		638.2*	Y
		(113.2)			

FIRST SUBDIVISION						
Denver Union Terminal YL						
STATION NUMBER	LENGTH OF SIDINGS	FEET	STATIONS		MILE POST	RULE 6(B)
			STATIONS			
14-640			DN-R 36th STREET YL	1.7	1.7	P
14-638			PULLMAN YL	0.5	2.2*	
			CP5 YL	2.7	4.9	IP
14-645			R COMMERCE CITY YL	0.3	5.2	P
14-646	500		ADAMS (SPUR-E) YL	0.9	6.1	P
			CP6 YL	0.2	6.3	P
14-648	4293		DUPONT	1.9	8.2	P
14-650	3140		ROLLA	2.4	10.6	p
14-652	7935		HAZELTINE	0.9	11.3	PX
			CP11		11.5	P
			CP13		12.9	PX
14-655	2998		HENDERSON	2.6	14.1	P
14-659	7960		D-R BRIGHTON	5.1	19.1	PX
			CP19		19.2	P
			CP21		20.7	PX
14-663	1161		POWARS	3.6	22.8	P
14-666	1040		LUPTON (SPUR-E)	3.0	25.8	P
14-671	2198		IONE	4.5	30.3	P
14-675	7975		PLATTEVILLE	4.5	33.9	PX
			CP34		34.8	P
			CP36		35.6	PX
14-680	5480		GILCREST	5.5	40.3	P
14-683	580		PECKHAM (SPUR-W)	2.1	42.4	P
			CP45	2.9	45.3	PX
14-687	9118		DN-R LA SALLE	0.8	46.1	P
			CP46	0.2	46.3	PX
			CP47	0.9	47.2	PX
14-689	590		EVANS (SPUR-W)	1.1	48.3	P
			CP51	2.4	50.7	P
14-692			D-R GREELEY	1.1	51.8	P
			CP53	0.7	52.5	P
			CP54	1.7	54.2	P
14-694			GILL	0.4	54.6	PY
			CP56	1.1	55.7	P
14-696	3740		LUCERNE	0.4	56.1	P
14-700	4056		EATON	2.7	58.8	P
			GW CROSSING	0.5	59.3	IP
14-703	7905		AULT	3.7	62.0	PX
			CP62		63.0	P
			CP64		63.7	PX
14-707	2929		PIERCE	3.7	66.7	P
14-712	7951		NUNN	5.0	71.2	PX
			CP71		71.7	P
			CP73		72.8	PX
14-717	1010		DOVER (SPUR-E)	5.3	77.0	
14-726	7355		CARR	8.9	84.6	PX
			CP85		85.9	P
			CP86		86.2	PX
				11.8		

WYOMING DIVISION - First Subdivision Branches

WESTWARD		DENVER CUT-OFF		EASTWARD	
STATION NUMBER	LENGTH OF SIDINGS	Timetable No. 7		MILE POST	RULE 6(B)
	FEET	STATIONS			
14-518	6489	SPEER JCT.	0.9	97.7	PY
		CP518	1.3	98.6†	PY
		W. SPEER	3.4	99.9‡	P
		CP519	0.3	103.3§	PX
14-519	5164 1314	BORIE		519.4	PX
		(113.4)			

(\* 638.2=2.2 (†) 98.6=518.3 No. 4 (‡) 99.9=519.8 No. 4 (§) 103.3=519.1 No. 1&2 Note 2 to Rule 99 is in effect on Denver Cut-off and First Subdivision.

Yard limits are continuous on Denver Cut-Off from MP 625.5 to MP 638.2 and on First Subdivision from 0.4 to 6.25.

CLEARANCE AND REGISTER REQUIREMENTS

Clearance need not be received by trains entering or leaving First Subdivision at Speer or Borie.

Only trains which originate or terminate at Roydale, Commerce City, Brighton, LaSalle or Greeley need register.

SPEED RESTRICTIONS - DENVER CUT-OFF AND FIRST SUBDIVISION

LOCATION	Pggr.	MPH Ft.
Maximum speed between Denver and Speer	79	60
Borie Cut-Off between Speer and Borie	50	50
Denver Union Terminal Speed Restrictions apply within interlocking limits at Denver.		
Rocky Mountain Arsenal trackage.		10
Beyond gate.		5
Between Mile Posts - Denver Yard		
0.4 and 3.0 both tracks	30	25
Maximum speed through Spring Switch at MP 4.0 on Union Pacific Track and on cut-off to DRGW Belt Line		12
Maximum speed on DRGW Belt Line to North Yard, Denver		20
Maximum speed over Diamond (Burlington-Northern and DRGW Railroad crossing at North Yard, Denver)		10
Maximum speed on all yard tracks at DRGW North Yard		10
3.0 and 6.6 until engine passes these locations	35	35
Brighton		
17.9 and 20.0 until engine passes these locations	40	40
Lupton		
25.5 and 26.3	40	40
LaSalle		
45.9 and 46.9 until engine passes these locations	20	20
46.9 and 48.0	60	50
Evans		
48.0 and 49.7	65	55
49.7 and 50.8	60	50
Greeley		
50.8 and 52.4 until engine passes these locations	20	20
Lucerne		
58.2 and 58.8	70	60
58.8 and 59.3	60	45
Carr		
86.30 and 86.45	70	60
91.8 and 96.1	70	60
96.1 and 97.7	60	50
97.7 and 97.8	25	25
97.8 and 98.5	40	40
102.6 and 103.3 (Borie Cut-Off)	15	15
Borie Cut-Off between Speer and Borie	50	50

WYOMING DIVISION

WESTWARD		SECOND SUBDIVISION		EASTWARD	
STATION NUMBER	LENGTH OF SIDINGS	Timetable No. 7		MILE POST	RULE 6(B)
	FEET	STATIONS			
510		DN-R	CHEYENNE YL CP511 YL	509.5 510.9	FPTXY PX
515	S900		5.0 WYCON (SPUR-E) 4.9	514.5	P
519	N1432 S4621		BORIE CP519 9.6 CP520	519.1 519.4 519.7	PX P PX
529	N4238		GRANITE CP528 7.6 CP530	528.5 529.5	PX P PX
537	C6151		BUFORD CP536 CP537	535.9 536.6 537.2	PX P PX
540	S1341		SHERMAN (SPUR-W) 3.8	540.4	PY
545	S1046		DALE (SPUR-E) 2.6	543.0	
			DALE JCT. CP545 1.8	544.8	PX
			3.5		
548	S772		HERMOSA CP547 CP549	547.3 548.3 548.6	PX P PX
554	N662		5.5 COLORES (SPUR-E) 7.9	553.8	
563	S369		FORELLE (SPUR-E) 7.9	561.7	
			4.3		
566		DN-R	LARAMIE CP565 CP567	565.3 566.0 567.4	PX FPY PX
			4.6	570.6	PX
			CP570		
			11.6	582.2	PX
			CP582		
			2.6		
585	C4300		BOSLER CP585	584.8	P
590	S634		5.8 COOPER LAKE (SPUR-E)	590.6	P
594	N1089		3.5 LOOKOUT (SPUR-W) CP594	594.1	PX
			6.9	601.0	PX
			CP601		
			4.2	605.2	PY
			ROCK RIVER CP605		
			3.8	609.0	PX
			WILCOX CP609		
			7.8	616.8	PX
			CP617		
623	C5984		6.7 MEDICINE BOW CP623	623.5	P
			1.0	624.5	PX
			CP624		
			8.1	632.6	PX
			CP633		
			6.4	639.0	PX
639	N19198		RAMSEY CP639		
			2.0	641.0	P
			CP641		
			2.0	643.0	PX
643	S19202	D-R	HANNA CP643		
649			7.1 DURRANT CP650	650.1	PX
657	N873		6.5 EDSON (SPUR-W)	656.6	P
			5.7		
662	N912 S2400		WALCOTT CP662	662.3	PX
			9.8	672.1	PX
			BENTON CP672		
			4.2	676.3	P
676	N2566		SINCLAIR		
			6.5		
683	N10788 N11990		CP678 CP680 CP681 CP683	678.0 680.3 681.2 682.7	PX PX PX PX
	S18700	DN-R	RAWLINS CP685	682.8 685.0	FP PX

CTC-ACS

TRACKS 1, 2

WYOMING DIVISION

WESTWARD		SECOND SUBDIVISION		EASTWARD	
STATION NUMBER	LENGTH OF SIDINGS	Timetable No. 7		MILE POST	RULE 6(B)
	FEET	STATIONS			
510		DN-R	CHEYENNE YL CP511 YL	509.5 510.9	FPTXY PX
15-518	S1115 C6740		8.8 SPEER CP517 CP518 CP520	517.2 518.3 519.3	PXY PXY PX
15-526	6558		7.3 EMKAY CP525	525.1 525.6 526.5	PX PX PX
15-534	6687		8.9 CP527		
15-534	6687		LYNCH CP533	533.5 534.5 534.9	PX PX PX
15-543	7079		8.6 CP535		
15-543	7079		HARRIMAN CP542	541.9 543.1 543.4	PX P PX
15-550	6492		6.9 CP543		
			PERKINS CP548	548.8 550.0 550.2	PX PX PX
			4.3 CP550		
			DALE JCT. CP545	554.3	PX
548	S772		HERMOSA CP547 CP549	B547.3 B548.3 B548.6	PX P PX
557	5852		8.4 RED BUTTES CPB556 CPB557	B556.1 B556.7 B557.4	PX PX PX
			8.6 CPB564	B565.3	PX
			0.3 CP565	B565.6	PX
566		DN-R	LARAMIE	565.6	FPY

<sup>1</sup>554.3 = 554.8 Nos. 1 & 2  
<sup>2</sup>B565.6 = 565.3 Nos. 1 & 2

Yard limits are continuous from MP 506.25 to 511.81.

Note 2 to Rule 99 is in effect on Second Subdivision.

**CLEARANCE AND REGISTER REQUIREMENTS**

Clearance need not be received by trains entering or leaving Second Subdivision at Speer or Borie.

For train movements on Medicine Bow and Energy Spurs see Special Rule 96 (RW) Second Subdivision.

Trains from Encampment Branch need not receive clearance at Walcott.

Only trains which originate or terminate at Laramie or Hanna need register.

On Coal Spurs, westward trains are defined as those trains moving to coal tipples and eastward trains as those moving from coal tipples.

**WYOMING DIVISION**  
**SPEED RESTRICTIONS — SECOND SUBDIVISION**

LOCATION	MPH	
	Pggr.	Frt.
Between Mile Posts— Cheyenne 509.1 and 510.5 until engine passes these locations Reduce speed signs located North side No. 1 track and South side No. 4 track also apply to tracks 2 and 3. 510.5 and 511.8	20	20
40		
Cheyenne yard: Yard lead at east end All yard leads at the west end North 1, 2, 6 and 7 tracks South 1, 2, 4 and 6 tracks Balloon track All other tracks	15 15 15 15 10 5	15 15 15 15 10 5
Maximum speeds between Cheyenne and Dale Junction No. 1 and No. 2 tracks: Maximum speeds including Dale Junction to CP565 No. 1 and No. 2 tracks: Dale Jct. No.1 & 2 tracks 540.7 and 544.1 No. 1 & 2 tracks 544.1 and 546.4 No. 3 track 553.5 and 555.1 All eastward trains with tonnage in excess of 100 tons per operative brake and operative dynamic brakes on all units in the consist must not exceed 20 MPH on No. 1 and No. 2 tracks from MP 536 to MP 519, and must not exceed 30 MPH from MP 519 to Cheyenne. Eastward trains with tonnage in excess of 100 tons per operative brake and which do not have effective dynamic brake on all units in consist must not exceed 20 MPH on No. 1 and No. 2 tracks from MP 536 to Cheyenne. IMPORTANT — for movement on descending grades see Special Rule 1042 (R).	70 45 55 40 40	55 40 45 40 40
Maximum speed on Borie Cut-Off between Speer and Borie 102.6 and 103.3	50 15	50 15
Maximum speed between Cheyenne and Dale Junction on No. 3 track and between Cheyenne and Speer on No. 4 track Less than 100 tons per operative brake with operative dynamic brake without operative dynamic brake More than 100 tons per operative brake with operative dynamic brake without operative dynamic brake	60 55 45 40 30	55 55 45 40 30
Maximum speed on No.3 track between CP 547 and CP 565* B-547.3 and B-549.0 B-549.0 and B-565.6 Important — For movement on descending grades see Special Rule 1042 (R)	45 70	40 60
Maximum speed between Laramie and Rawlins	79	70
Laramie Tie yard lead between MP 565.6 and MP 565.85		10
Live Scale Track Warehouse Tracks 2, 3, 4		5 5
Maximum Speed — Coal Spur Tracks		
Ramsey Spur (Arch II, Rosebud and Carbon County) 0.0 and 3.6 2.7 and 2.9 (Arch Siding Only) 3.6 and 4.2		25 15 15
Hanna (Energy and Medicine Bow Suprs) Energy Spur 0.0 and 0.7 0.7 and 3.4 Medicine Bow Spur 0.0 and 0.4 (MP 0 at switch from Energy Spur) 0.4 and 3.0 3.0 and 12.7 12.7 and 12.8 12.8 and 13.1		30 40 15 20 40 10 25

\*Note — Between CP 547 and CP 565 via Red Buttes mile post numbers are prefixed with letter B.

**WYOMING DIVISION**  
**SPEED RESTRICTIONS — SECOND SUBDIVISION CONT.**

LOCATION	MPH	
	Pggr	FRT
Durant (Arch I) 0.0 and 5.2		40
Other trackage on coal spurs		5
Hanna Yard trackage south of south siding Other trackage		10 5
Rawlins sidings in accordance with signal indications, not exceeding 682.3 and 682.8, until engine has passed over hand operated switches	40	40 20
20		20
Between Mile Posts — No. 1 and No. 2 tracks Borie 522.1 and 525.6		55 45
Granite 530.0 and 532.1 537.9 and 540.4 540.7 and 544.1 544.1 and 546.4		55 50 55 40
40		40
CPB-564 and CP 570 (SIDING ONLY)		40
Bosler 587.7 and 588.4 593.3 and 593.7 598.5 and 602.5		70 65 65
75		65
Medicine Bow 637.5 and 637.8		70
70		60
Ramsey 639.9 and 643.5 (SOUTH SIDING ONLY NORTH RUNNING TRACK ONLY)		40 30
40		30
Hanna 643.4 and 643.7 645.1 and 648.0		70 60
70		60
Durrant 650.2 and 650.7 653.1 and 656.4 661.0 and 661.5 662.8 and 666.5		70 60 75 60
70		60

**TRAIN MOVEMENTS**

Train movements on Ramsey Spur are authorized by Radio Block clearance. See Special Rule 96 (RW-1).

WYOMING DIVISION

WESTWARD		THIRD SUBDIVISION	EASTWARD	
STATION NUMBER	LENGTH OF SIDINGS	Timetable No. 7	MILE POST	RULE 6(B)
	FEET			
683	11602	DN-R RAWLINS	682.8	FPXY
	19126			
690	600-791	2.2 CP685	685.0	PX
		5.2 HADSELL (SPUR E-W)	690.2	P
		9.4 CP700 (SPUR-E)	699.6	PX
		1.1 RINER	700.7	P
701	1500	1.5 CP702	702.2	PX
		9.8		
712	W2865	CRESTON	712.0	PY
	C10002			
724	W11200 E9080	D WAMSUTTER	724.2	PXY
733	X2547	8.5 RED DESERT	732.7	PX
740	W2470	7.3 TIPTON	740.0	PX
743	5000	4.1 ROBINSON (SPUR-W)	744.1	P
747	E10279	2.6 TABLE ROCK	746.7	PI
749	400	2.0 CIG SPUR (SPUR-W)	748.7	
752	300	3.0 MONELL (SPUR-E)	751.7	P
754	3200	1.9 PATRICK DRAW (SPUR-W)	753.6	
		3.8		
757	W11000 E10298	BITTER CREEK	757.4	PXi
	W6560			
766	W7340 X871	8.6	766.0	PX
	771	N3185	0.7 CP766	766.0
4.5 BLACK BUTTES			766.7	PX
777	C8103	6.2 HALLVILLE (SPUR-W)	771.2	P
784	W12550	6.7 POINT OF ROCKS	777.4	PX
		4.5 THAYER	784.1	PX
789	312	7.5 SALT WELLS (SPUR-W)	788.6	P
796	C5646	4.7 BAXTER (SPUR-W)	796.1	P
		1.3 CP801	800.8	PX
802	16690	D ROCK SPRINGS	802.1	PXY
		2.0 CP804	804.1	PX
809	X6294	4.9 KANDA	809.0	PX
		5.7 CP814 YL	814.7	PX
817		0.4 CENTER GREEN RIVER YL	815.1	PX
		1.9 DN-R GREEN RIVER YL	817.0	FPTXY
		(134.2)		

Yard limits are continuous from MP 814.6 to 817.7.

CLEARANCE REQUIREMENTS

All trains with interdivisional crews will receive clearance at Green River but need not register.

Note 2 to Rule 99 is in effect on Third Subdivision.

Rules 251 to 253 inclusive are in effect on Third Subdivision between CP702 and CP801. Rule 261 in effect between Rawlins and CP702 and between CP801 and Green River and at CP766.

WYOMING DIVISION

SPEED RESTRICTIONS — THIRD SUBDIVISION		
LOCATION	MPH	
	Pgr.	Tr.
Maximum speed between Rawlins and Rock Springs	79	70
Between Rock Springs and Green River	79	60
Jim Bridger spur — maximum speed	25	10
MP 4.0 and 4.7	10	10
MP 6.2 and 8.0	10	10
Spurs not otherwise shown		10
Rawlins, sidings, in accordance with signal indications not exceeding	40	40
MP 682.3 and MP 682.8 until engine has passed over hand operated switches	20	20
MP 816.7 and MP 816.9, Green River, Tracks 1, 2 & Running Tracks until engine has passed over hand operated switches	20	20
Green River Running Tracks	30	30
Between Mile Posts — Both Tracks		
CP 700 and CP 702 (SIDING ONLY)	40	40
703.0 and 704.2	70	60
708.6 and 709.0	70	60
Creston		
713.7 and 714.3	70	60
Tipton		
740.2 and 740.9	70	60
742.7 and 743.1 (On Westward Track Only)	70	60
Bitter Creek		
760.5 and 762.3	70	60
Hallville		
774.3 and 776.6	70	60
Baxter		
797.3 and 798.4	55	45
798.4 and 800.5	60	50
Rock Springs		
800.8 and 804.0 (SIDING ONLY)	40	40
800.5 and 801.25	65	55
801.25 and 803.25	40	40
803.25 and 803.5	65	55
806.6 and 807.5	70	60
807.5 and 807.8	60	50
Kanda		
809.6 and 814.1	55	45
814.1 and 816.7	40	30
816.9 and 818.2	40	30

TRAIN MOVEMENTS

Train movements on Jim Bridger Spur are authorized by Radio Block clearance. See Special Rule 96 (RW-1).

# WYOMING DIVISION

WESTWARD		FOURTH SUBDIVISION		EASTWARD	
STATION NUMBER	LENGTH OF SIDINGS	Timetable No. 7		MILE POST	RULE 6(B)
	FEET	STATIONS			
817		DN-R	GREEN RIVER YL CP817	817.0	FP TXY
			2.1 CP819	819.4	P
825	805		5.9 PERU (SPUR-E) CP825	824.9	PX
830	824		0.3 BRYAN (SPUR-W)	830.2	P
831			0.5 TENNECO (SPUR-E)	830.7	
			2.7 CP833	833.4	PX
834			0.7 STAUFFER (SPUR-E)	834.1	P
835			1.0 ALCHEM CP835	835.1	P
838			2.2 WESTVACO	837.3	PX
843			0.2 TG SODA (SPUR-E)	842.5	P
			3.3 CP844	843.9	PX
847	15057		6.8 CENTER GRANGER CP847	847.2	PXY
9-0854	C 5795		11.9 VERNE	854.0	P
9-0866	X 2180		9.5 HAMPTON	865.9	PX
9-0875	C 6277		5.2 CARTER	875.4	P
9-0881	C 1221		5.0 ANTELOPE	880.6	P
9-0886	C 6068		4.9 BRIDGER	885.6	P
9-0891	C 983		7.1 LEROY	890.5	P
9-0898	C 5807		2.5 SPRING VALLEY	897.6	P
9-0902			4.1 ASPEN	900.1	PX
9-0904	4944		8.5 ALTAMONT	904.2	PX
9-0913	C 1267		4.5 MILLIS (SPUR-E)	912.7	P
9-0917	W 8875 E 8264	D	9.9 EVANSTON	917.2	PXY
9-0928	C 4254		5.0 WAHSATCH (SPUR-W-E)	927.1	P
9-0933	241		4.1 CURVO (SPUR-E)	932.1	P
9-0936	4651-762		7.1 CASTLEROCK (SPUR-W-E)	936.2	P
9-0943	C 5797		4.6 EMORY (SPUR-E)	943.3	P
9-0948	400		4.8 BASKIN (SPUR-E)	947.9	P
9-0952	E 5845 W 5556		4.4 ECHO	952.7	PX
9-0957	C 5489		4.0 HENEFER	957.1	P
9-0961	C 5483		7.6 DEVIL'S SLIDE	961.1	P
9-0968	C 5546		7.4 MORGAN	968.7	P
9-0976	C 5494		1.6 PETERSON (SPUR-W)	976.1	P
9-0978			7.4 STRAWBERRY CP977	977.7	PX
9-0985	995-3324		3.5 UINTAH (SPUR-W-E)	985.1	P
			1.3 EAST RIVERDALE CP988	988.6	PX
9-0990			2.7 RIVERDALE YL CP990	989.9	PX
9-0993		DN-R	OGDEN YL	992.6	FPY
			(175.6)		

Westward trains must keep to the left from MP 931.5, to Strawberry.

Eastward trains must keep to the left from Strawberry to MP 931.5.

Note 2 to Rule 99 is in effect on Fourth Subdivision.

Rules 251 and 253 inclusive are in effect on Fourth Subdivision between Center Granger and Aspen and between Altamont and Strawberry. Rule 261 is in effect between Green River and Center Granger, between Aspen and Altamont and between Strawberry and Riverdale.

Signal 9174 has vertical number plate.

CTC-ACS is in effect on No. 1 and No. 2 tracks between Strawberry and Riverdale, and on Riverdale By-Pass Track between East Riverdale and W. Bridge Jct, CP 818.

ABS-ACS is in effect on No. 1 and No. 2 tracks between Riverdale and Ogden Union Depot.

Movements on Tenneco, TG Soda and Stauffer Spurs are governed by staff system. Staffs are located in metal boxes near Tenneco, TG Soda and Stauffer Spur main track entering switches.

Yard limits are continuous from MP 814.6 to 817.7 and MP 989.5 to Ogden — Utah Division.

## CLEARANCE REQUIREMENTS

Eastward trains enroute to Wyoming Division at Granger must receive Wyoming Division clearance in addition to Idaho Division clearance at their initial station and need not receive clearance at Granger.

Westward trains enroute to Idaho Division at Granger must receive Idaho Division clearance in addition to Wyoming Division clearance at their initial station and need not receive clearance at Granger.

Eastward interdivisional trains from Utah Division must receive Wyoming Division clearance, in addition to Utah Division clearance at Salt Lake City.

Westward interdivisional trains enroute to Utah Division must receive Utah Division clearance in addition to Wyoming Division clearance at their initial station.

All trains with interdivisional crews will receive clearance at Green River, but need not register.

Only trains which originate or terminate at Ogden need register or receive clearance at Ogden. Trains not required to register or receive clearance at Ogden must acknowledge receipt to train dispatcher of any clearance or train orders received at Ogden.

## SPEED RESTRICTIONS — FOURTH SUBDIVISION

LOCATION	MPH	
	Reg.	Frt.
MP 816.7 and MP 816.9, Green River, Tracks 1, 2 & Running Tracks until engine has passed over hand operated switches	20	20
Green River Running Tracks	30	30
Maximum speed between: Green River and Evanston	79	65
Evanston and Ogden	79	50
Tenneco Spur		25
0.0 and 8.8		10
Stauffer Spur		25
7.0 and 8.0		10
Alchem Spur		15
TG Soda Spur		40
MP 0.0 and MP 0.6		30
MP 3.6 and MP 4.8		15
MP 4.8 and MP 5.2		5
Westvaco running track		10
Granger, sidings-CP 844 and CP 847 CP 847 and CP 2	40	40
Ogden, between East Riverdale and W. Bridge Jct. CP 818 on Bypass Track.	40	40
<b>Between Mile Posts — Both Tracks</b>		
Green River		
814.1 and 816.7	40	30
816.9 and 818.2	40	30
818.2 and 820.7	60	50
822.4 and 823.6	60	50
Peru		
825.4 and 826.6	70	60
827.9 and 828.4	70	60
Bryan		
833.6 and 834.1	70	60
TG Soda		
844.8 and 845.4	65	65
Granger		
849.9 and 850.2	70	60
860.1 and 860.3	70	60
862.2 and 862.5	70	60
Hampton		
866.7 and 869.2	70	60
870.9 and 874.5	70	60
Carter		
878.2 and 878.5	70	60
880.1 and 880.3	60	50
Antelope		
880.3 and 882.5	70	60
882.5 and 885.0	60	50

**SPEED RESTRICTIONS — FOURTH SUBDIVISION CONT.**

Bridger		70	60
885.0 and 887.3			
887.3 and 887.5		65	50
LOCATION	MPH Psgr. Frt.	LOCATION	MPH Psgr. Frt.
<b>Between Mile Posts — Westward Track</b>			
Leroy			
887.5 and 896.1		70	60
896.1 and 901.7		60	45
<b>Between Mile Posts — Both Tracks</b>			
Altamont and Aspen Tunnels			
901.7 and 903.6		50	40
Altamont			
903.6 and 908.6		60	45
908.6 and 910.4		75	65
Millis			
910.4 and 915.6		70	60
915.6 and 916.0		60	45
916.0 and 917.6		60	35
Evanston			
917.9 and 919.1		60	45
920.6 and 921.1		70	50
Between Mile Posts — Westward Track	MPH Psgr. Frt.	Between Mile Posts — Eastward Track	MPH Psgr. Frt.
925.9 and 926.5		925.9 and 926.5	
926.5 and 927.5		926.5 and 939.1	
927.5 and 928.8		940.9 and 941.6	
928.8 and 935.8		941.6 and 942.9	
Castle Rock			
935.8 and 939.4		50	40
939.4 and 942.9		55	45
Between Mile Posts — Both Tracks	MPH	Between Mile Posts — Both Tracks	MPH
Emory		Emory	
942.9 and 952.1		952.1 and 952.5	
952.1 and 952.5		952.5 and 954.5	
952.5 and 954.5		958.1 and 959.5	
958.1 and 959.5		959.8 and 962.8	
959.8 and 962.8		963.1 and 965.1	
963.1 and 965.1		967.2 and 967.8	
967.2 and 967.8		972.4 and 972.6	
972.4 and 972.6		974.1 and 976.1	
974.1 and 976.1		977.0 and 977.3	
977.0 and 977.3		978.7 and 980.3	
978.7 and 980.3		980.3 and 983.8	
980.3 and 983.8		981.0 and 983.5	
981.0 and 983.5		983.5 and 987.9	
983.5 and 987.9		987.9 and 989.5	
987.9 and 989.5			

**WYOMING DIVISION — First Subdivision Branches**

STATION NUMBER	LENGTH OF SIDINGS FEET	DENT BRANCH Timetable No. 7 STATIONS	EASTWARD	
			MILE POST	RULE 6(B)
		CP5 YL	4.9	P
20-648	747	3.3 WELBY (SPUR-W)	8.2	
20-650	1455	1.6 QUIMBY (SPUR-W)	9.8	
20-652		1.9 NORTHGLENN (SPUR-E)	11.7	
20-654	1710	2.1 EAST LAKE	13.8	
20-663	2538	8.4 ST. VRAINS YL	22.2	Y
20-667	4420	3.9 FREDERICK	26.1	
20-675	201	8.5 GOWANDA (SPUR-W)	34.6	
20-677		2.3 RIVERS (SPUR-E)	36.9	
20-683	984	5.9 DENT YL	42.8	Y
20-691		7.8 DN-R LA SALLE YL	50.6	FPY
		(45.6)		

Between Denver and LaSalle, extra trains will run via Lupton unless otherwise instructed.

Yard limits are continuous between Dent and LaSalle.

Trains or engines must receive verbal authority from train dispatcher before movement may be made between Dent and LaSalle.

**CLEARANCE AND REGISTER REQUIREMENTS**

Westward trains via Dent Branch must receive clearance at 36th Street.

Eastward trains via Dent Branch must receive clearance at LaSalle.

Only trains which originate or terminate at LaSalle need register.

Trains from Boulder or Fort Collins Branches need not receive clearance.

**SPEED RESTRICTIONS**

LOCATION	MPH	LOCATION	MPH
Dent Branch		Between Mile Posts —	
Maximum speed.	40	21.5 and 21.9	15
Between mile posts		25.6 and 25.8	15
MP 5.0 to MP 6.4	20		

STATION NUMBER	LENGTH OF SIDINGS FEET	FORT COLLINS BRANCH Timetable No. 7 STATIONS	EASTWARD	
			MILE POST	RULE 6(B)
20-683	984	DENT YL	0.0	Y
138-02	1500	1.7 MILLIKEN YL	1.7	
		7.3 GW CROSSING	9.0	
138-09		0.1 KELIM	9.1	
138-14	480	4.6 BOYD LAKE (SPUR-W)	13.7	
138-20	2055	5.8 HARMONY	19.5	
138-25	2644	5.5 D FORT COLLINS YL	25.0	Y
		0.2 BN CROSSING YL	25.2	
		0.1 BN CROSSING YL	25.3	
138-28	536	2.6 POUDRE (SPUR-W) YL	27.9	
138-30		2.1 BOETTCHER YL	30.0	
		0.8 END OF TRACK YL	30.8	
		(30.8)		

Yard limits continuous between Dent and Milliken and from MP 21.8 to end of track MP 30.8.

**WYOMING DIVISION - First Subdivision Branches**
**SPEED RESTRICTIONS**

LOCATION	MPH
<b>Fort Collins Branch</b> Maximum speed	<b>25</b>
Dent, over west Wye switch. MP 0.04	10
Between Mile Posts <b>12.75 and 18.50</b>	<b>10</b>
MP 22.6 until engine has passed over Prospect Street	10

WESTWARD		BOULDER BRANCH		EASTWARD	
STATION NUMBER	LENGTH OF SIDINGS	Timetable No. 7		MILE POST	RULE 6(B)
	FEET	STATIONS			
20-663		R	ST. VRANS YL	8.2	Y
136-10	5929		EAGLE MINE (SPUR-W) 2.0	10.1	
136-15	477		ERIE 5.0	15.1	
			BN CROSSING 0.0	15.1	
136-24	1022		VALMONT 8.9	24.0	
			BN CROSSING 2.0	26.0	
136-28			BOULDER YL 0.9	26.7	
			(18.6)		

At Boulder, trains and engines are governed by Operating Rules, timetable and special instructions of BN while using their tracks.

**SPEED RESTRICTIONS**

LOCATION	MPH
<b>Boulder Branch</b> Maximum speed	<b>25</b>
Between Mile Posts — <b>8.1 and 15.1</b> <b>24.0 and 26.9</b>	<b>15</b> <b>10</b>
Lakeside Spur MP 1, over BN crossing.	10
Lakeside Lead	5

**WYOMING DIVISION - Second Subdivision Branches**

WESTWARD		ENCAMPMENT BRANCH		EASTWARD	
STATION NUMBER	LENGTH OF SIDINGS	Timetable No. 7		MILE POST	RULE 6(B)
	FEET	STATIONS			
662			WALCOTT 6.8	0.0	P
116-07	569		MEADS 17.3	6.8	
116-24	1090		SARATOGA 0.2	24.1	
			END OF TRACK	24.3	
			(24.3)		

Movements on Encampment Branch governed by staff system — Special Rule 300 (R) governs. Staff located in box on phone booth MP 661.87 at Walcott.

**SPEED RESTRICTIONS**

LOCATION	MPH
<b>Encampment Branch</b> Maximum speed.	<b>40</b>
Between Mile Posts — <b>0.0 and 1.0</b>	<b>15</b>
<b>24.1 and 24.3</b>	<b>10</b>

WESTWARD		COALMONT BRANCH		EASTWARD	
STATION NUMBER	LENGTH OF SIDINGS	Timetable No. 7		MILE POST	RULE 6(B)
	FEET	STATIONS			
566		DN-R	LARAMIE YL	0.0	FPXY
21-015	1223		MILLER 14.7	14.7	
21-030	1077		CENTENNIAL (SPUR-E) 15.0	29.7	
21-040	453		ALBANY 10.7	40.4	
21-055	932		FOX PARK 14.2	54.6	PY
21-064	2851		WYOCOLO 9.2	63.8	
21-071	1601		CAMP 7.0	70.8	
21-074	997		KINGS CANON (SPUR-E) 2.8	73.6	
21-080	1497		NORTHGATE 6.2	79.8	Y
21-088	1068		BROWNLEE 8.5	88.3	
21-092	3336	D-R	WALDEN YL 3.9	92.2	P
			LARAND YL 8.5	100.7	
			HEBRON YL 6.9	107.6	
			END OF TRACK YL 0.4	108.0	
			(108.0)		

Yard limits are continuous from MP 92 to 101.

**SPEED RESTRICTIONS**

LOCATION	MPH
<b>Coalmont Branch</b> Maximum speed.	<b>25</b>
Between Mile Posts — <b>15.3 and 17.5</b>	<b>20</b>
<b>29.6 and 30.4</b>	<b>15</b>
<b>35.8 and 38.1</b>	<b>20</b>
<b>38.1 and 48.3</b>	<b>10</b>
<b>48.3 and 53.7</b>	<b>20</b>
<b>53.7 and 56.0</b>	<b>15</b>
<b>56.2 and 77.9</b>	<b>10</b>
<b>92.0 and 93.7</b>	<b>15</b>
<b>93.7 and 101.0</b>	<b>5</b>

**Wyoming Division — Third and Fourth Subdivision Branches**

WESTWARD		SOUTH PASS BRANCH		EASTWARD	
STATION NUMBER	LENGTH OF SIDINGS	Timetable No. 7		MILE POST	RULE 6(B)
	FEET	STATIONS			
802		D	ROCK SPRINGS YL	0.0	PXY
117-06			6.0 RELiance YL	6.0	Y
117-10	2580		3.5 WINTON JUNCTION YL	9.5	
			(9.5)		

Yard limits are continuous from junction switch Rock Springs through Winton Jct.

**SPEED RESTRICTIONS**

LOCATION	MPH
South Pass Branch Maximum speed	15
Reliance Spur	5
Stansbury Spur	15

WESTWARD		PARK CITY BRANCH		EASTWARD	
STATION NUMBER	LENGTH OF SIDINGS	Timetable No. 7		MILE POST	RULE 6(B)
	FEET	STATIONS			
9-0952			ECHO	0.0	P
126-04	800		4.0 CALGAS (SPUR-E)	4.0	
126-06	771		1.7 COALVILLE	5.7	
126-13	911		7.7 WANSHIP	13.4	
126-25	840		11.1 KEETLEY JCT.	24.5	
126-28			2.9 PARK CITY	27.4	Y
			(27.4)		

WESTWARD		ONTARIO BRANCH		EASTWARD	
STATION NUMBER	LENGTH OF SIDINGS	Timetable No. 7		MILE POST	RULE 6(B)
	FEET	STATIONS			
126-25			KEETLEY JCT.	0.0	
127-02			2.2 PHOSTON	2.2	
			0.3 END OF TRACK	2.5	
			(2.5)		

**CLEARANCE REQUIREMENTS**

Trains from Park City Branch need not receive clearance at Echo, but must obtain verbal authority from train dispatcher before occupying Fourth Subdivision tracks.

Park City and Ontario Branches are governed by staff system. Special Rule 300(R) governs. Staff located in staff box in phone booth at Echo.

Staff required for movement between MP 0.33 and end of branch. Between MP 0.00 and MP 0.33 Rule 105 will apply.

**SPEED RESTRICTIONS**

LOCATION	MPH
Park City Branch Maximum Speed.	25
Between Mile Posts — 0.0 and 3.25	15
3.25 and 3.75	10
3.75 and 4.3	15
5.1 and 5.2	15
13.2 and 13.5	15
14.8 and 19.0	10
19.0 and 21.0	15
24.0 and 24.1	15
25.1 and 25.2	15
26.3 and 27.4	15
Ontario Branch Maximum Speed.	15

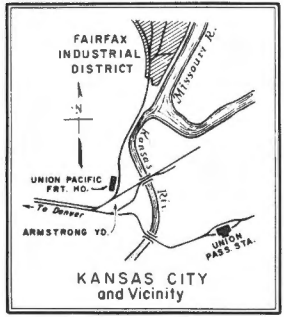
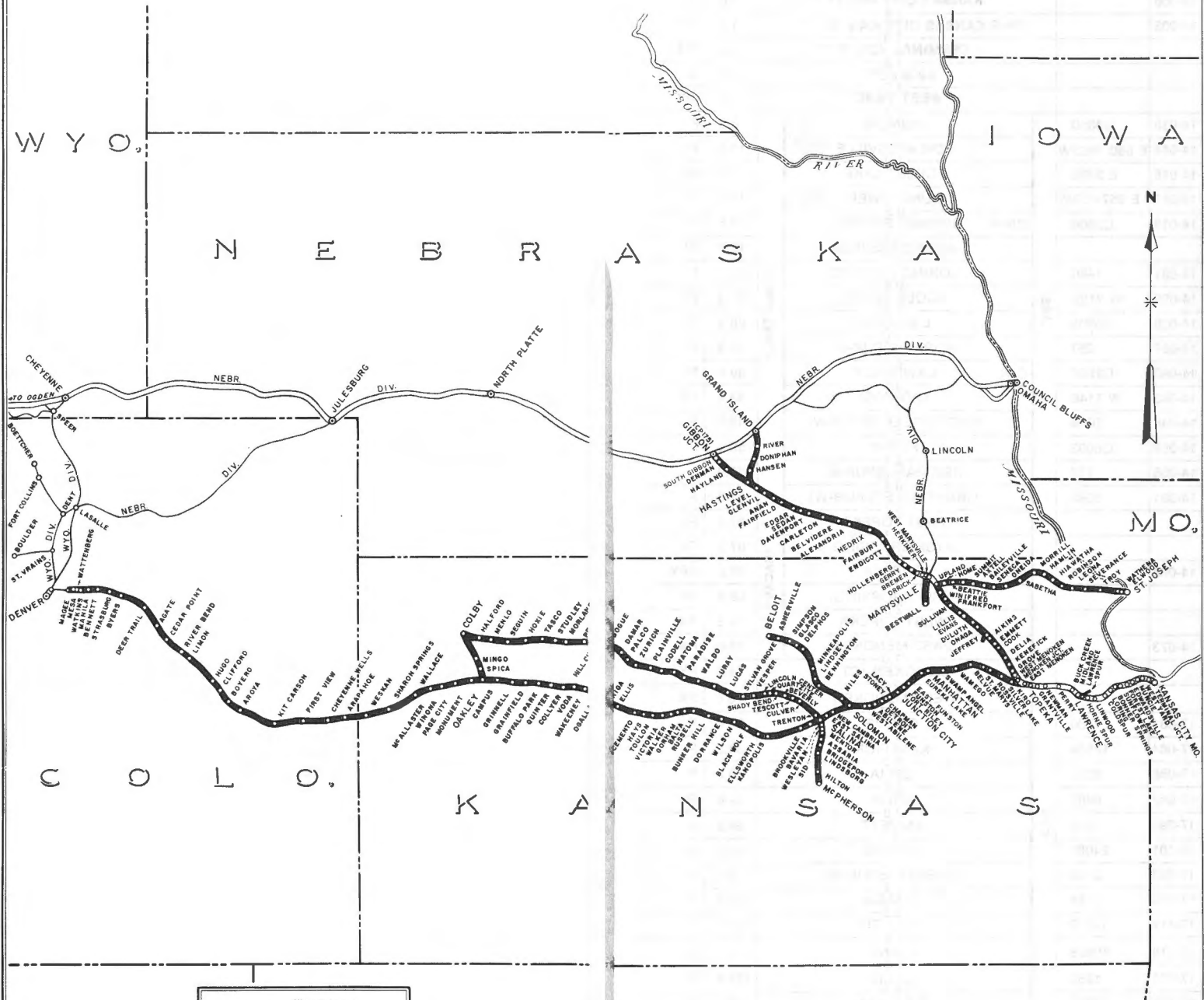

**UNION PACIFIC RAILROAD**  
**EASTERN DISTRICT**  
**KANSAS DIVISION**  
 SCALE OF MILES  
 10 0 10 20 30 40 50 100  
 OFFICE OF CHIEF ENGINEER - OMAHA, NEBR.  
 C.E. DRAWING NO. 82726

# KANSAS DIVISION

WESTWARD		FIRST SUBDIVISION	EASTWARD		
STATION NUMBER	LENGTH OF SIDINGS	Timetable No. 7		MILE POST	RULE 6(B)
	FEET	STATIONS			
14-000		<b>KANSAS CITY MO. YL *</b>		0.0	IP
14-003		DN-R <b>KANSAS CITY KAN. YL **</b>		1.4	IFTY
		<b>TERMINAL JCT. YL**</b>		3.3	IPX
		<b>KAW JCT.**</b>		5.2	IX
		<b>WEST YARD**</b>		6.4	IPX
14-010	C4350	MUNCIE		8.9	P
14-014	E 560-1620W	EDWARDSVILLE (SPUR E-W)		13.9	P
14-015	E 3339	FOREST LAKE		15.0	PX
14-017	E 257-663W	SUNFLOWER (SPUR E-W)		16.7	P
14-018	C2806	DN-R BONNER SPRINGS		17.5	P
		ATSF CROSSING		18.0	IP
14-021	1480	LORING (SPUR-E)		20.7	P
14-022	W 2122	COLD SPUR		21.3	PX
14-028	C5905	LINWOOD		28.3	P
14-037	257	HORNE (SPUR-E)		37.3	P
14-040	C1997	D-R LAWRENCE		39.6	P
14-043	W 1146	MIDLAND		43.2	PX
14-046	1089	BUCK CREEK (SPUR-W)		46.1	P
14-052	C6093	PERRY		52.1	P
14-056	717	NEWMAN (SPUR-E)		55.9	
14-061	1593	GRANTVILLE (SPUR-W)		61.3	P
		EAST TOPEKA		67.4	PX
		ATSF CROSSING		67.5	PX
14-068	6571	DN-R TOPEKA		68.0	FPX
		SSW CROSSING		68.2	IP
		WEST TOPEKA		70.2	PX
14-073		EAST MENOKEN		73.0	PX
		<b>MENOKEN JCT.</b>		74.0	PY
		WEST MENOKEN		76.0	PX
17-081	1730	GROVE		80.7	P
17-084	12502	KENEFICK		84.2	P
17-088	2031	DELIA		88.2	P
17-092	9467	COOK		92.0	P
17-095	1808	EMMETT		94.8	P
17-101	24081	AIKINS		102.0	P
17-103	3100	JEFFREY (SPUR-W)		102.2	PX
17-110	1854	ONAGA		109.9	P
17-112	12512	DULUTH		112.7	P
17-118	10938	EVANS		118.3	P
17-122	1950	LILLIS		121.8	P
17-127	12837	SULLIVAN		126.8	P
		MOPAC CROSSING		130.9	IP
17-131	9887	D FRANKFORT		131.8	P
17-137	6162	WINIFRED		137.0	P
17-143		UPLAND		142.6	P
17-148		DN-R MARYSVILLE		148.1	FPTXY
		(148.1)			

Yard limits are continuous MP 0.0 to MP 4.0

Rules 251 to 253 inclusive apply between West Yard MP 6.4 and East Topeka. Rule 261 in effect between East Topeka and Marysville.

\*Four Main Tracks between Kansas City, Mo. MP 0.0 and K.C., Ks. MP 1.4.

\*\*Two Main Tracks between K.C., Ks. MP 1.4 and West yard MP 6.4.

Note 2 to Rule 99 is in effect on First Subdivision.

Trains to or from Denver Cut-Off need not receive clearance at Menoken.

All trains must register by registering ticket at Kansas City.

Trains from St. Joseph Branch will retain their identity and need not receive clearance at Upland.

At Kansas City, trains to Denver Cut-Off must receive clearance from Denver dispatcher and from Kansas City dispatcher.

Only Trains which originate or terminate need register at Bonner Springs, Lawrence or Topeka.

Westward SSW trains must receive clearance at SSW yard office, Kansas City and eastward SSW trains must receive clearance at SSW Tower, Topeka.

## SPEED RESTRICTIONS — FIRST SUBDIVISION

LOCATION	MPH
Maximum speed	<b>70</b>
Kansas City on Running Tracks 1 and 2 between Kaw River Bridge and end of block sign at State Line and on Running Tracks 3 and 4 between Kaw River Bridge and 11th Street	<b>15</b>
Until entire movement has cleared video cameras at the following locations both inbound and outbound.	
On Interchange Lead MP 1.9	<b>10</b>
On both Elevator Track 1 and Elevator Track 2	<b>5</b>
On Main tracks west end Kaw River Bridge MP 1.04	<b>10</b>
Between Mile Posts —	
Armstrong	
<b>1.86 and 3.31</b> (Elevator Track 1)	<b>20</b>
<b>1.46 and 1.86</b> (Inbound and outbound trains)	
(Elevator Track 1 and No. 2)	<b>5</b>
Terminal Jct.	
<b>3.28 and 3.30</b>	<b>30</b>
<b>4.6 and 7.4</b>	<b>80</b>
Edwardsville	
<b>13.1 and 13.4</b>	<b>60</b>
<b>16.3 and 17.2</b>	<b>55</b>
Bonner Springs	
<b>17.9 and 18.0</b>	<b>30</b>
<b>20.1 and 20.5</b>	<b>60</b>
Loring	
<b>21.4 and 21.8</b>	<b>60</b>
<b>23.6 and 23.9</b>	<b>60</b>
<b>25.3 and 25.6</b>	<b>60</b>
<b>26.3 and 26.6</b>	<b>60</b>
<b>27.5 and 27.8</b>	<b>60</b>
Linwood	
<b>33.1 and 33.4</b>	<b>60</b>
<b>36.5 and 36.9</b>	<b>50</b>
Lawrence	
<b>38.5 and 40.5</b>	<b>40</b>
<b>42.5 and 43.1</b>	<b>60</b>
Lawrence spur — Maximum speed	<b>5</b>
Grantville	
<b>65.7 and 66.3</b>	<b>60</b>
Topeka	
<b>67.2 and 68.5</b> (on No. 2 Track Only)	<b>20</b>
<b>67.2 and 69.6</b> (on No. 1 Track Only)	<b>20</b>
<b>70.0 and 71.5</b>	<b>40</b>
Menoken (West leg of Wye)	<b>20</b>
<b>76.6 and 76.8</b>	<b>60</b>
<b>78.5 and 78.7</b>	<b>60</b>
<b>79.7 and 79.9</b>	<b>60</b>
Grove	
<b>81.3 and 81.6</b>	<b>60</b>

**SPEED RESTRICTIONS — FIRST SUBDIV. CONTD.**

LOCATION	MPH
Emmett 99.0 and 99.4	50
Jeffrey Spur — Maximum speed Beyond, MP 5.6	25 10
Aikins 106.1 and 106.4	60
109.2 and 109.6	50
117.3 and 117.9	60
Mo Pac Crossing 130.7 and 131.1	45
Winifred 140.3 and 140.6	50
Marysville Freight trains entering and using yard tracks.	10
147.3 and 147.8	35
147.8 and 148.4	20
Marysville — over street crossings	20
148.4 and 149.3 until engine passes these locations	20

**KANSAS DIVISION**

WESTWARD		SECOND SUBDIVISION	EASTWARD	
STATION NUMBER	LENGTH OF SIDINGS	STATIONS	MILE POST	RULE 6(B)
	FEET			
17-148		DN-R MARYSVILLE	148.1	FPTXY
		1.3 CP 149	149.4	PX
		0.9 WEST MARYSVILLE	150.3	PX
17-153	2227	3.2 HERKIMER (SPUR-W)	153.5	P
		2.0 ORRICK	155.5	P
17-158	12120	3.1 BREMEN	158.6	P
17-163	13514	5.9 GERRY	164.5	P
17-172	12776	7.1 HOLLENBERG	171.6	P
		8.8 BN CROSSING	180.4	IP
17-182	1487	0.2 ENDICOTT	180.6	P
17-188	13353	4.0 FAIRBURY	184.6	P
17-194	9227	9.0 HEDRIX	193.6	P
17-203	12725	8.3 ALEXANDRIA	201.9	P
17-212	6375	7.4 BELVIDERE	209.3	P
		0.9 BN CROSSING	210.2	IP
17-219	13024	5.9 D CARLETON	216.1	P
17-226	13179	9.9 DAVENPORT	226.0	P
17-231	3049	3.6 SEDAN	229.6	P
		4.1 BN CROSSING	233.7	IP
17-236	12553	1.2 EDGAR	234.9	P
17-244	6404	6.8 FAIRFIELD	241.7	P
17-249	12765	6.3 ANAN	248.0	P
17-253	2599	3.5 GLENVIL	251.5	P
17-257	19163	3.5 LEVEL	256.4	PY
		4.1 BN CROSSING	260.5	IP
17-262	12922	3.2 D-R HASTINGS	263.7	PY
17-275	12992	10.2 HAYLAND	273.9	P
17-283	9996	5.9 DENMAN	279.8	P
		5.4 CP 285	285.2	P
		2.7 GIBBON JCT. (CP 175)	287.9	PY
		(139.8)		

Note 2 to Rule 99 is in effect on Second Subdivision.

**CLEARANCE REQUIREMENTS**

Trains to or from Nebraska Division need not receive clearance at Gibbon Jct. (CP175).

**SPEED RESTRICTIONS — SECOND SUBDIVISION**

LOCATION	MPH
Maximum Speed	70
Between Mile Posts — Marysville Freight trains entering and using yard tracks.	10
148.4 and 149.3 Until engine passes these locations	20
Hanover Industry spur 0.0 and 1.7	25
Fairbury 185.9 and 186.9	30
188.4 and 188.7	50
189.5 and 189.9	55
190.9 and 191.3	55
196.9 and 197.2	60
198.3 and 199.7	50
Carleton 217.8 and 218.1	55
218.6 and 219.2	55
223.3 and 223.8	55
Hastings Kansas Ave. Lead to Tracks 5, 6, 7	5
No. 7 Track	5
South Yard Tracks	5
260.0 and 262.7	30
285.2 and 287.7 (On No. 1 Track Only)	40
287.4 and 287.7 (On No. 2 Track Only)	40

KANSAS DIVISION

KANSAS DIVISION

**KANSAS DIVISION**

WESTWARD		DENVER CUT-OFF SALINA SUBDIVISION		EASTWARD	
STATION NUMBER	LENGTH OF SIDINGS	Timetable No. 7		MILE POST	RULE 6(B)
	FEET	STATIONS			
14-073		CTC	EAST MENOKE	73.0	PXY
14-075	1615		2.2 KIRO	75.2	P
14-079	4578		3.5 SILVER LAKE	78.7	P
14-084	6558		4.9 ROSSVILLE	83.6	P
14-092	4068		8.0 D ST. MARYS	91.6	P
14-098	2032		6.2 BELVUE	97.8	
14-105	7007		6.9 WAMEGO	104.7	
14-115	324		10.1 SWAMP ANGEL (SPUR-E) YL	114.8	
14-118	1042		3.4 INDUSTRIAL PARK (SPUR-W) YL	118.2	
14-119	6774		1.1 D-R MANHATTAN YL	119.3	P
14-126	906		6.6 EUREKA LAKE (SPUR-W)	125.9	
14-132	6386		5.7 EAST FUNSTON	131.6	
14-134			2.0 FUNSTON	133.6	
14-136			2.1 D FORT RILEY	135.7	
14-140	6873	3.8 D-R JUNCTION CITY YL	139.5	PXY	
14-143	W565 E808	3.5 LACY (SPUR-E-W)	143.0		
14-151	1679	7.6 STONE (SPUR-W)	150.6		
14-152	6591	1.7 CHAPMAN	152.3		
14-159	1178	6.2 DETROIT	158.5		
14-164	5818	5.2 DN-R ABILENE YL	163.7	P	
14-165		0.8 ATSF CROSSING YL	164.5	AP	
14-172	1791 3528	0.2 WEST ABILENE YL	164.7		
14-180	4132	7.6 D SOLOMON YL	172.3	PY	
14-185		7.6 NEW CAMBRIA	179.9		
14-187		4.7 EAST SALINA YL	184.6	P	
14-195	2763	2.0 DN-R SALINA YL	186.6	FPTY	
14-201	5275	0.6 ATSF CROSSING	187.2	A	
14-219	2917	7.6 BAVARIA	194.8	P	
14-224	4902 5103	6.1 BROOKVILLE	200.9	P	
14-232	1660	18.4 DN KANOPOLIS	219.3	PY	
14-240	2584	4.4 ELLSWORTH	223.7	P	
14-246	2925	0.7 BN CROSSING	224.4	I	
14-253	1111	7.1 BLACK WOLF	231.5	P	
14-263	3022	8.4 WILSON	239.9	P	
14-267	775	6.3 DORRANCE	246.2	P	
14-272	5024	7.2 BUNKER HILL	253.4	P	
14-276	1305	10.2 RUSSELL	263.6	P	
14-280	899	2.9 BALTA	266.5	P	
14-285	1291	5.9 GORHAM	272.4	P	
14-290	5278	3.1 WALKER	275.5	P	
14-295	1030	4.1 VICTORIA	279.6	P	
14-303	3748	5.2 TOULON	284.8	P	
		5.3 HAYS	290.1	P	
		5.2 YOCEMENTO (SPUR-E)	295.3		
		8.0 ELLIS	303.3	PY	

**KANSAS DIVISION**

WESTWARD		DENVER CUT-OFF SALINA SUBDIVISION CONT.		EASTWARD		
STATION NUMBER	LENGTH OF SIDINGS	Timetable No. 7		MILE POST	RULE 6(B)	
	FEET	STATIONS				
14-303	3748	D	ELLIS 5.1	303.3	PY	
14-308	2719		RIGA 4.7	308.4	P	
14-314	1412		OGALLAH 9.2	313.1		
14-322	2336		WAKEENEY 7.7	322.3	P	
14-330	806		VODA 5.8	330.0		
14-336	1437		COLLYER 7.5	335.8	P	
14-343	3610		QUINTER 7.6	343.3	P	
14-351	3032		BUFFALO PARK 5.4	350.9	P	
14-356	1810		GRAINFIELD 8.9	356.3	P	
14-365	2370		GRINNELL 6.0	365.2	P	
14-371	3400		CAMPUS 6.2	371.2	P	
14-377	5726		DN-R OAKLEY YL	377.4	PY	
			(304.4)			

Note 2 to Rule 99 is in effect on Salina Subdivision.

**CLEARANCE AND REGISTER REQUIREMENTS**

Westward trains enroute to Denver Cut-Off must receive clearance at Topeka.

Westward ATSF trains at Abilene must receive clearance at ATSF depot.

Only trains which originate or terminate need register at Manhattan, Junction City, or Abilene.

At Salina UP trains enroute to First Subdivision must receive clearance from Kansas City Dispatcher in addition to clearance from Denver Cut-Off Dispatcher.

ATSF trains having received clearance at Abilene or Salina need not receive clearance at West Abilene or East Salina.

Trains to or from First Subdivision need not receive clearance at Menoken Jct.

**SPEED RESTRICTIONS**

**DENVER CUT-OFF — SALINA SUBDIVISION**

LOCATION	MPH	LOCATION	MPH
Maximum speed.		148.7 and 148.9	50
Between Menoken and Salina	65	149.9 and 150.3	50
Between Salina and Oakley	60	Chapman, within city limits.	
Menoken		152.1 and 152.7	40
(West Leg of Wye)	20	Abilene, between Oplena and Elm Streets.	
Silver Lake, within city limits.		163.3 and 164.0	25
78.6 and 78.9	45	Abilene, over ATSF crossing.	
Rossville, within city limits.		164.5	25
83.7 and 84.4	45	165.9 and 166.2	50
St. Marys, within city limits.		167.9 and 168.3	35
91.0 and 91.8	30	169.3 and 169.6	50
94.7 and 95.0	55	Solomon	
Belvue		172.3 and 172.4	35
99.7 and 99.8	55	173.3 and 173.5*** Note	30
104.6 and 104.8* Note	35	New Cambria	
Wamego		181.2 and 181.3	50
105.4 and 107.0	50	Salina, over Ohio Street Crossing	
117.8 and 118.2	55	185.2	30
118.8 and 119.0	50	Over ATSF crossing.	
119.1 and 119.4	25	187.2	25
Manhattan		190.6 and 190.9	55
121.9 and 122.0	50	Brookville	
123.1 and 123.5	35	201.7 and 202.2	50
124.7 and 125.3	50	203.9 and 208.1	50
East Funston		208.4 and 208.4	45
132.5 and 132.7	50	210.0 and 212.8	30
133.7 and 137.2** Note	30		
Junction City			
141.0 and 141.5	55		
143.6 and 145.3	35		

**KANSAS DIVISION**

**SPEED RESTRICTIONS**

**DENVER CUT-OFF — SALINA SUBDIVISION CONT.**

LOCATION	MPH	LOCATION	MPH
213.1 and 216.1	30	Russell	
216.3 and 217.1	45	263.0 and 264.2	35
Kanopolis		Victoria, within city limits.	
221.9 and 224.5	30	279.2 and 279.6	40
224.6 and 225.0	45	Hays, within city limits.	
225.6 and 225.8	55	288.6 and 290.4	35
228.3 and 228.7	50	301.8 and 302.6	35
230.6 and 230.9	45	302.6 and 303.6	20
Black Wolf		303.6 and 307.0	40
231.7 and 233.5	35	Wakeeney	
234.7 and 234.8	45	322.2 and 322.4	
235.0 and 236.2	35	Between first crossing west and second crossing east of depot	25
238.4 and 238.6****Note	55	323.3 and 324.0	40
Wilson, within city limits.		331.7 and 332.1	50
239.6 and 240.4	40	335.0 and 335.5	50
Dorrance		Collyer	
249.5 and 250.0	45	336.5 and 337.1	45

Note — Referring to Rule 12(D)

- \* Resume speed sign for eastward trains south of siding at Wamego.
- \*\* Reduce speed sign for westward trains north of main track at Funston.
- \*\*\* Reduce speed sign for westward trains north of siding at Solomon.
- \*\*\*\*Reduce speed sign for eastward trains on left side of track.

WESTWARD		DENVER CUT-OFF DENVER SUBDIVISION		EASTWARD	
STATION NUMBER	LENGTH OF SIDINGS	Timetable No. 7		MILE POST	RULE 6(B)
	FEET	STATIONS			
14-377	5726	DN-R	OAKLEY YL	377.4	PY
14-386	2456		MONUMENT	386.1	P
14-394	1915		PAGE CITY	393.6	P
14-399	1788		WINONA	399.0	P
14-408	855		McALLASTER	408.4	P
14-421	2168		WALLACE	421.2	P
14-430	3599	D	SHARON SPRINGS	429.8	PY
14-442	3082		WESKAN	441.8	P
14-453	1829		ARAPAHOE	453.3	P
14-463	2670	D	CHEYENNE WELLS	463.0	P
14-474	2451		FIRST VIEW	473.5	P
14-488	2806		KIT CARSON	487.5	P
14-508	2292	ABS	AROYA	507.6	P
14-518	2576		BOYERO	517.7	P
14-526	4760		CLIFFORD	526.7	P
14-536	3777		HUGO	535.8	PY
14-551	2075		LIMON YL	550.5	P
			LIMON JUNCTION YL	550.6	P
14-557	712		RIVER BEND (SPUR-E)	556.4	P
14-563	4947		CEDAR POINT	563.0	P
14-572	4837		AGATE	571.7	P
14-584	2483 2262		DEER TRAIL	584.0	P
14-597	2426		BYERS	596.4	P
14-603	1099		STRASBURG	602.5	P
14-609	4976		BENNETT	609.3	P

**KANSAS DIVISION**

WESTWARD		DENVER CUT-OFF DENVER SUBDIVISION CONT.		EASTWARD	
STATION NUMBER	LENGTH OF SIDINGS	Timetable No. 7		MILE POST	RULE 6(B)
	FEET	STATIONS			
14-609	4976		BENNETT	609.3	P
14-614	2600		MANILA	613.7	P
14-618	4632		WATKINS	618.4	P
14-622	970		WATTENBERG (SPUR-E)	622.5	
14-625	2700		MESA YL	625.0	P
14-628	817		MAGEE YL	628.1	P
			(250.7)		

Yard limits are continuous from MP 625.5 to 638.2.

Note 2 to Rule 99 is in effect on Denver Subdivision.

**CLEARANCE AND REGISTER REQUIREMENTS**

Trains enroute to Kansas Division must receive clearance at 36th Street.

**SPEED RESTRICTIONS  
DENVER CUT-OFF — DENVER SUBDIVISION**

LOCATION	MPH
Maximum speed: Between Oakley and Magee	60
Between Mile Posts — Oakley	
383.4 and 384.3	50
Winona	
401.3 and 401.8	50
405.5 and 405.8	45
419.6 and 420.5	50
Wallace	
424.9 and 425.0	50
Sharon Springs	
429.9 Until engine passes crossing *Note	20
Weskan	
450.8 and 451.1	50
Arapahoe	
454.5 and 454.6	50
Cheyenne Wells	
Within City Limits	50
512.4 and 512.7	50
Hugo	
534.8 and 536.6	35
537.7 and 537.9	50
543.9 and 544.9	50
546.3 and 546.6	50
River Bend	
556.6 and 559.3	40
561.3 and 562.1	50
562.9 and 567.2	45
Deer Trail	
587.2 and 589.8	40
Byers	
588.9 and 601.5	50
Strasburg	
605.2 and 607.1	50
Watkins	
619.3 and 620.5	50

\*Note referring to Rule 12(D)

Reduce speed sign for Westward trains located on left side of track.  
Resume speed sign for Eastward trains located on left side of track.

**KANSAS DIVISION — First Subdivision Branches**

WESTWARD		ST. JOSEPH BRANCH		EASTWARD	
STATION NUMBER	LENGTH OF SIDINGS	Timetable No. 7		MILE POST	RULE 6(B)
	FEET	STATIONS			
18-113		DN-R	ST. JOSEPH TERM. YD. YL	0.0	P
18-112	3768		ELWOOD YL	1.7	
18-108	1420		WATHENA	4.8	
18-099	930		TROY	13.9	
18-089	1668		SEVERANCE	24.8	
18-084	1703		LEONA	28.9	
18-079	1358		ROBINSON	34.2	
			MoPac CROSSING	42.2	A
18-071	1805	D	HIAWATHA YL	42.7	PY
18-063	870		HAMLIN	50.1	
18-059	1230		MORRILL	53.9	
18-053	4694		SABETHA	60.7	
18-045	1497		ONEIDA	68.8	
18-036	1420		SENECA	77.2	
18-029	1262		BAILEYVILLE	84.2	
18-024	2014		AXTELL	89.2	
18-019	571		SUMMIT (SPUR-E)	94.1	
18-014	1838		BEATTIE	99.3	
18-008	1550		HOME	105.2	
17-143			UPLAND	107.8	P
			(107.8)		

Trains from St. Joseph Branch will retain their identity and need not receive clearance at Upland.

**SPEED RESTRICTIONS — ST. JOSEPH BRANCH**

LOCATION	MPH
Maximum Speed	40
Missouri River Bridge — St. Joseph	5
Between Mile Posts — 7.0 and 13.8	10
Troy 14.0 and 26.3	25
Robinson 40.6 and 40.9	30
Over MoPac Crossing — Hiawatha 42.2	25
43.6 and 44.7	25
51.0 and 51.4	25
54.0 and 58.5	30
Sabetha, until engine passes public crossings 60.4 and 60.9	30
73.2 and 73.8	30
Seneca, until engine passes public crossings 75.8 and 75.9 76.7 and 77.5	25 30
82.1 and 89.0	25
Axtell within City Limits 94.5 and 95.0	25
99.4 and 101.3	30

**KANSAS DIVISION — First and Second Subdivision Branches**

WESTWARD		BESTWALL SPUR		EASTWARD	
STATION NUMBER	LENGTH OF SIDINGS	Timetable No. 7		MILE POST	RULE 6(B)
	FEET	STATIONS			
17-148		DN-R	MARYSVILLE YL	0.0	FPT
133-45	1796		BESTWALL	10.3	

**SPEED RESTRICTION — BESTWALL SPUR**

LOCATION	MPH
Between Marysville and Bestwall	20

Staff System (Special Rule 300-R) is in effect on Bestwall Spur between yard limit sign at Marysville and Bestwall. Staff will be received from and must be returned to operator at Marysville.

WESTWARD		GRAND ISLAND BRANCH		EASTWARD	
STATION NUMBER	LENGTH OF SIDINGS	Timetable No. 7		MILE POST	RULE 6(B)
	FEET	STATIONS			
17-262		DN-R	HASTINGS YL	0.0	PY
131-08	3266		HANSEN	6.8	
131-13	1623		DONIPHAN	12.2	
131-19	737		RIVER (SPUR-W) YL	18.4	
			BN CROSSING YL	21.5	
147		DN-R	GRAND ISLAND YL	22.3	PY
			(22.3)		

Yard limits are continuous from MP 18 to end of branch.

Staff System (Special Rule 300-R) is in effect on Grand Island Branch between yard limit sign at Hastings and yard limit sign at Grand Island. Staff will be received from and must be returned to yard office at Hastings. When crew is released at Grand Island, staff must be delivered to operator who must consult train dispatcher before returning staff to crew.

**SPEED RESTRICTIONS — GRAND ISLAND BRANCH**

LOCATION	MPH
Between Hastings and Grand Island	25
BN Crossing MP 21.5	20

**KANSAS DIVISION — Denver Cut-Off Branches**

WESTWARD		PLAINVILLE BRANCH		EASTWARD	
STATION NUMBER	LENGTH OF SIDINGS	Timetable No. 7		MILE POST	RULE 6(B)
	FEET	STATIONS			
14-187		DN-R	SALINA YL	0.0	FPTY
16-003	1014		TRENTON	3.4	
16-012	1276		CULVER	11.5	
16-019	1501		TESCOTT (SPUR-E)	18.5	P
16-024	2466		BEVERLY	23.8	P
16-026	194		SHADY BEND (SPUR-W)	26.4	
16-033	967		QUARTZITE (SPUR-W)	32.9	
16-034	1421		LINCOLN CENTER	33.2	P
			ATSF CROSSING	33.8	I
16-041	2468		VESPER	40.7	
16-047	1938		SYLVAN GROVE	46.9	P
16-056	1714		LUCAS	56.0	P
16-065	1753		LURAY	65.4	P
16-072	2061		WALDO	71.5	
16-079	1258		PARADISE	79.2	P
16-087	1618		NATOMA	87.0	P
16-095	1478		CODELL	95.1	
16-104	1899	D-R	PLAINVILLE YL	103.5	PY
16-110	1783		ZURICH	110.4	
16-118	1110		PALCO	117.8	P
16-123	1091		DAMAR	122.7	
16-129	1265		BOGUE	129.3	P
16-138	1157		HILL CITY	138.0	PY
16-145	1186		PENOKEE	144.7	
16-150	1306		MORAND	150.2	
16-155	1338		STUDLEY	155.4	
16-163	1239		TASCO	162.5	
16-170	1495		HOXIE	170.4	P
16-179	1233		SEGUIN	179.1	
16-186	1450		MENLO	186.2	
16-194	1149		HALFORD	194.0	
16-204	946		COLBY	203.5	Y
16-213	1952		MINGO	212.5	
16-218	1350		SPICA (SPUR-E)	218.0	
14-377		DN-R	OAKLEY YL	224.7	PY
			(224.7)		

**SPEED RESTRICTIONS — PLAINVILLE BRANCH**

LOCATION	MPH	LOCATION	MPH
Maximum Speed	40	94.1 and 98.5	25
Quartzite		101.2 and 102.8	25
0.0 and 6.6	25	Palco-Damar	
6.6 and 21.8	30	115.5 and 125.0	30
21.8 and 31.0	25	129.0 and 137.9	30
33.0 and 34.0	25	Hill City, until engine passes	
37.0 and 51.5	30	Crossing	
51.5 and 52.9	25	137.9	5
Lucas		137.9 and 177.5	30
61.5 and 63.8	30	Exception:	
Waldo		165.3 (Bridge)	20
67.0 and 79.0	30	194.0 and 203.1	30
83.7 and 85.9	25	Colby over east leg of wye	
Natoma		203.1 and 203.3	15
87.8 and 88.0	25	Oakley	
		223.8 and 224.5	15

**KANSAS DIVISION — Denver Cut-Off Branches**

WESTWARD		SOLOMON BRANCH		EASTWARD	
STATION NUMBER	LENGTH OF SIDINGS	Timetable No. 7		MILE POST	RULE 6(B)
	FEET	STATIONS			
14-172		D-R	SOLOMON YL	0.0	PY
129-07	3042		NILES	6.5	
129-15	2541		BENNINGTON	14.7	
129-21	628		LINDSEY	20.9	
129-23	704		MINNEAPOLIS	23.3	
			ATSF CROSSING	23.7	
129-35	1683		DELPHOS	34.7	
129-42	1617		GLASCO	41.6	
129-47	1476		SIMPSON	46.8	
129-50	1190		ASHERVILLE	49.8	
			MoPac CROSSING	57.2	
129-57	1374	D-R	BELOIT YL	57.4	
			(57.4)		

WESTWARD		McPHERSON BRANCH		EASTWARD	
STATION NUMBER	LENGTH OF SIDINGS	Timetable No. 7		MILE POST	RULE 6(B)
	FEET	STATIONS			
14-187		DN-R	SALINA YL	0.0	FPTY
			ATSF CROSSING	0.5	
			MoPac CROSSING	0.6	
130-03	153		WESLEYAN (SPUR-E)	2.9	
130-05	686		SID	5.3	
130-08	1618		MENTOR	8.0	
130-12	1513		ASSARIA	12.2	
130-16	822		BRIDGEPORT	15.8	
			MoPac CROSSING	20.7	
130-21	1257		LINDSBORG	20.9	
130-30	1459		HILTON	30.3	
			ATSF CROSSING	35.1	
130-35	1154	D	McPHERSON	35.4	
			(35.4)		

**SPEED RESTRICTIONS**

LOCATION	MPH	LOCATION	MPH
Solomon Branch		McPherson Branch	
Maximum speed	30	Maximum speed	40
Between Mile Posts —		Between Mile Posts —	
20.2 and 21.0	10	0.0 and 5.1	10
22.7 and 23.7	10	25.2 and 33.0	30
24.5 and 57.4*	10	34.8 and 35.8	10
Thru Niles, Verdi (9.2)		Over Crossings at:	
Bennington & Lindsey	25	MP 8.1, (10.07 (eastward	
		trains) — 5 mph)	
		13.1, 21.6	10
		MP 33.8	25
		Thru Assaria	25

\*Eastward resume speed sign placed on north side of track.

# SOUTH-CENTRAL DISTRICT

**R. E. IRION**  
General Manager

**J. E. SANFORD**  
General Superintendent

## UTAH DIVISION

### J. R. HART

G. R. JENSEN  
F. L. HEBDON  
D. E. BERGERON  
J. S. MAUGHAN  
W. L. MILTON  
J. B. PEAY  
D. E. GODDEN  
G. F. CHERRY  
D. P. McALLISTER  
T. R. NIPKO  
D. W. KRAFZCIK  
B. J. CAIN  
O. G. STOCKHAUS  
A. D. WALLACE  
R. FIDEL  
M. J. GALLAWA  
M. L. RAWLINSON  
G. W. UNDERWOOD  
W. S. NUA  
C. G. DANA  
A. J. HILL  
K. S. KERR  
G. H. MAXWELL  
D. C. JONES  
K. A. STAPLES  
R. A. FORBES

### Superintendent

Division Assistant Superintendent  
Terminal Superintendent  
Assistant Terminal Superintendent  
Terminal Trainmaster  
Terminal Trainmaster  
Terminal Trainmaster  
Road Foreman-Assistant Trainmaster  
Terminal Superintendent  
Assistant Terminal Superintendent  
Terminal Trainmaster  
Road Foreman-Assistant Trainmaster  
Trainmaster  
Assistant Trainmaster  
Assistant Trainmaster  
Assistant Trainmaster (DRGW)  
Trainmaster  
Trainmaster  
Road Foreman-Assistant Trainmaster  
Road Foreman-Assistant Trainmaster  
Assistant Director of Safety  
Manager of Safety  
Safety Engineer-M/W  
Division Engineer  
General Roadmaster  
Mechanical Supt.-West  
Manager-Operating Rules

### Salt Lake City, Utah

Salt Lake City, Utah  
Salt Lake City, Utah  
Salt Lake City, Utah  
Salt Lake City, Utah  
Salt Lake City, Utah  
Salt Lake City, Utah  
Ogden, Utah  
Ogden, Utah  
Ogden, Utah  
Ogden, Utah  
Clearfield, Utah  
Clearfield, Utah  
Clearfield, Utah  
Clearfield, Utah  
Provo, Utah  
Milford, Utah  
Milford, Utah  
Las Vegas, Nevada  
Salt Lake City, Utah  
Salt Lake City, Utah  
Salt Lake City, Utah  
Salt Lake City, Utah  
Salt Lake City, Utah  
Salt Lake City, Utah

## CALIFORNIA DIVISION

### D. M. WHEELER

L. D. SMITH  
P. G. WALKER  
W. E. THOMPSON  
C. W. CRAWFORD  
G. R. TROUTMAN  
W. J. STEELE  
D. R. BORLA  
T. M. LINDSEY  
R. W. PIPPIN, JR.  
G. A. PETERSON  
R. J. LAMPE  
R. E. MAIN  
R. L. SALOGA  
L. W. STOHS  
D. R. LYON  
R. C. KLEPPER  
W. B. ELLIOTT  
T. M. SHEPARD  
H. M. DUNN, JR.  
F. H. BITHELL  
F. D. WENGERT  
H. C. STEELMAN  
D. J. IPSEN  
A. D. McGINNIS

### Superintendent

Division Assistant Superintendent  
Dir. Harbor Oprns.  
Trainmaster  
Trainmaster  
Terminal Superintendent  
Assistant Terminal Superintendent  
Intermodal Terminal Superintendent  
Terminal Trainmaster  
Terminal Trainmaster  
Intermodal Terminal Trainmaster  
Terminal Trainmaster  
Terminal Superintendent  
Terminal Trainmaster  
Trainmaster  
Terminal Superintendent  
Asst. Term. Supt.  
Road Foreman-Asst. Trainmaster  
Road Foreman-Asst. Trainmaster  
Road Foreman-Asst. Trainmaster  
Division Engineer  
Asst. Div. Engineer  
Manager of Safety  
Manager-Operating Rules

### Los Angeles, Calif.

Los Angeles, Calif.  
Los Angeles, Calif.  
Los Angeles, Calif.  
Los Angeles, Calif.  
Los Angeles, Calif.  
Los Angeles, Calif.  
Los Angeles, Calif.  
Los Angeles, Calif.  
Los Angeles, Calif.  
Los Angeles, Calif.  
Yermo, Calif.  
Yermo, Calif.  
Yermo, Calif.  
Las Vegas, Nev.  
Las Vegas, Nev.  
Las Vegas, Nev.  
Los Angeles, Calif.  
Los Angeles, Calif.  
Las Vegas, Nev.  
Los Angeles, Calif.  
Los Angeles, Calif.  
Los Angeles, Calif.  
Los Angeles, Calif.

### DIVISION CHIEF DISPATCHER

C. H. WHITE ..... Salt Lake City, Utah

### CHIEF DISPATCHER

B. S. SCHULTHIES ..... Salt Lake City, Utah

### Assistant Chief Train Dispatchers

J. T. HOLYOAK ..... Salt Lake City, Utah  
D. R. HACKING ..... Salt Lake City, Utah  
J. A. WORKMAN ..... Salt Lake City, Utah  
S. A. MADSEN ..... Salt Lake City, Utah  
J. L. CLARKEN ..... Salt Lake City, Utah  
J. L. BUNDY ..... Salt Lake City, Utah  
J. H. COX ..... Salt Lake City, Utah  
G. L. ADAMS ..... Salt Lake City, Utah  
R. C. SHIRING ..... Salt Lake City, Utah

### UTAH DIVISION MILEAGE

Main Track ..... 731.6  
Branches ..... 263.1  
Total ..... 994.7

### CALIFORNIA DIVISION MILEAGE

Main Track ..... 336.0  
Branches ..... 80.7  
Total ..... 416.7

### STANDARD CLOCKS ARE LOCATED AS SHOWN BELOW:

**Salt Lake City** ..... Switchmen's Locker Room, 13th North  
..... Register Room, Passenger Station  
..... Train Dispatcher's Office  
..... Trainman's Register Room, North Yard Office  
..... Engineer's Register Room, North Yard  
..... Switchmen's Register Room, North Yard  
..... Hostler's Register Room, North Yard

**Clearfield** ..... Yard Office, Freeport Center

**Ogden** ..... Yard Office, 28th Street  
..... Trainmen's Register Room, 33rd Street  
..... Switchmen's Locker Room, 33rd Street  
..... Switchmen's Locker Room, 28th Street  
..... Switchmen's Locker Room, Riverdale

**Pocatello** ..... Switchmen's Locker Room, Hump  
..... Train Dispatcher's Office  
..... Communications Office  
..... Switchmen's Locker Room, New Yard  
..... Crew Dispatcher's Office

**Provo** ..... Yard Office

**Milford** ..... Telegraph Office

**Las Vegas** ..... Enginemen's Locker Rooms  
..... Conductor's Register Room  
..... Tower  
..... East Carman's Register Room

**Yermo** ..... Telegraph Office  
..... Conductors Register Room

**East Yard, Los Angeles** ..... Switchmen's Locker Room  
..... Enginemen's Locker Room  
..... Conductor's Register Room  
..... Harbor Register Room

**East Los Angeles** ..... Telegraph Office

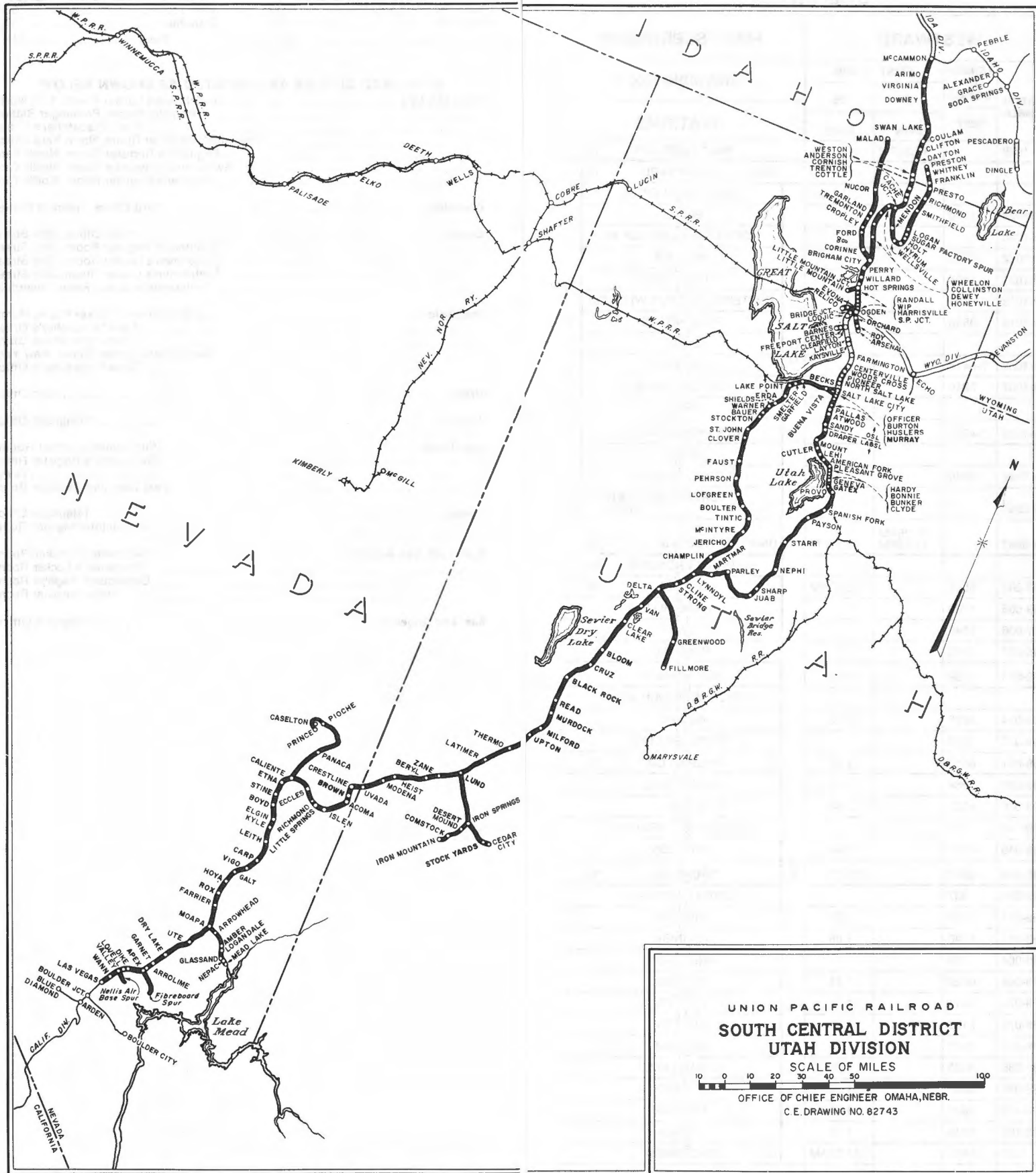

UTAH DIVISION

WESTWARD		FIRST CLASS		FIRST SUBDIVISION	
STATION NUMBER	LENGTH OF SIDINGS	Timetable No. 7		STATIONS	
		5	25		
	FEET	Daily	Daily		
9-1029		10.30PM		SALT LAKE CITY	YL
				DN-R NORTH YARD	YL
				18TH NORTH CP785	YL
9-1026	4140			BECKS	
9-1024				NORTH SALT LAKE CP788	
9-1022	4680			PIONEER	
9-1021	2404			WOODS CROSS	
9-1018	780			CENTERVILLE (SPUR-W) CP793	
9-1014	3556			FARMINGTON	
				CP802	
9-1009	2-6418			KAYSVILLE	
9-1007	2210			LAYTON CP804	
				CP807	
9-1002	C-4727			CLEARFIELD CP809	
				CP811	
9-0994	2640			LODJIC (SPUR-E)	
9-0994				BRIDGE JCT CP817 YL CP818	
				1.0	
9-0993		11.25PM 11.45PM	11.55PM	DN-R OGDEN	YL
				DRGW CROSSING	YL
99-002	6573		12.02AM	S P JCT.	YL
99-005	1500			HARRISVILLE	
99-006	1140			WIP	
99-007	1140			RANDALL	
99-009	5938		12.08	HOT SPRINGS	
				LITTLE MOUNTAIN JCT.	
99-014	5965		12.13	WILLARD	
99-017	1050			PERRY (SPUR-W)	
99-021	6519		12.20	D BRIGHAM CITY	YL
99-030	5984		12.29	HONEYVILLE	
99-036	6039		12.34	DEWEY	
99-040	540			COLLINSTON (SPUR-W)	
99-045	6010		12.42	WHEELON	
99-049	8619		s12.55	CACHE JCT.	YL
99-056	937			COTTLE (SPUR-E)	
99-057	6102		1.03	TRENTON	
99-061	1740		1.06	CORNISH	
99-064	780			ANDERSON	
99-065	6022		1.11	WESTON	
99-071	6011		1.17	DAYTON	
99-075	2100		1.20	CLIFTON	
99-078	6007		1.24	COULAM	
99-085	6005		1.29	SWAN LAKE	
99-095	5991		1.39	DOWNEY	
99-100	3600		1.44	VIRGINIA	
99-105	6046		1.49	ARIMO	
1038	5991		A1.57AM	D McCAMMON	
				(147.2)	

UTAH DIVISION

FIRST SUBDIVISION		EASTWARD		
TIMETABLE NO. 7		FIRST CLASS		RULE 6(B)
STATIONS	MILE POST	26	6	
		Daily	Daily	
SALT LAKE CITY	YL	782.8	A6.35AM	P
DN-R NORTH YARD	YL	783.6		FIFTY
18TH NORTH CP785	YL	785.5		PX
BECKS		786.1		P
NORTH SALT LAKE CP788		787.5		PX
PIONEER		789.2		P
WOODS CROSS		791.0		PX
CENTERVILLE (SPUR-W) CP793		793.2		PX
FARMINGTON		797.3		P
CP802		802.5		P
KAYSVILLE		803.2		P
LAYTON CP804		804.2		P
CP807		807.2		PX
CLEARFIELD CP809		808.7		PXY
CP811		811.5		PX
LODJIC (SPUR-E)		816.7		P
BRIDGE JCT. CP817 YL CP818		817.2 817.5		PX PX
1.0				
DN-R OGDEN	YL	0.0	5.20AM	5.40AM 5.25AM
DRGW CROSSING	YL	0.7		A
S P JCT.	YL	2.5	5.04	P
HARRISVILLE		4.7		
WIP		5.8		P
RANDALL		6.3		
HOT SPRINGS		9.0	4.58	P
LITTLE MOUNTAIN JCT.		9.5		PY
WILLARD		14.6	4.53	P
PERRY (SPUR-W)		17.3		
D BRIGHAM CITY	YL	21.1	4.46	PY
HONEYVILLE		30.4	4.36	P
DEWEY		35.7	4.31	P
COLLINSTON (SPUR-W)		40.3		
WHEELON		44.0	4.23	P
CACHE JCT.	YL	48.6	S4.10	PXY
COTTLE (SPUR-E)		55.8		
TRENTON		56.6	4.02	P
CORNISH		60.6	3.58	
ANDERSON		63.8		
WESTON		65.4	3.54	P
DAYTON		71.4	3.48	P
CLIFTON		75.2	3.45	
COULAM		78.8	3.42	P
SWAN LAKE		84.4	3.37	P
DOWNEY		95.0	3.28	P
VIRGINIA		100.4	3.23	
ARIMO		104.8	3.19	P
D McCAMMON		111.2	3.12AM	PY
(147.2)				

Note 2 to Rule 99 is in effect on First Subdivision.

On single track except in CTC territory, westward trains are superior to trains of the same class in the opposite direction. See Rule 72.

### CLEARANCE REQUIREMENTS

Trains From	En Route To	Must Receive	In Addition To	At	Need not receive clearance at
Utah Division	Idaho Division	Idaho Div. clearance	Utah Div. clearance	Salt Lake City	McCammon
Idaho Division	Utah Division	Utah Div. clearance	Idaho Div. clearance	Pocatello or Montpelier	McCammon
Utah Division	Wyoming Division	Wyo. Div. clearance	Utah Div. clearance	Salt Lake City	Ogden
Wyo. Division	Utah Division	Utah Div. clearance	Wyo. Div. clearance	Green River	Ogden

Only trains which originate or terminate at Ogden need register at Ogden.

Eastward Utah Division trains must identify opposing trains between Pocatello and McCammon, and between Montpelier and McCammon.

### UTAH DIVISION

#### SPEED RESTRICTIONS — FIRST SUBDIVISION

LOCATION	MPH	
	PSGR	FRT
<b>Between Salt Lake City and Ogden</b>		
Maximum Speed		
Between Mile Posts — 782.8 and 817.8	70	70
Salt Lake Salt Lake Switching District when moving in or out of industry tracks		5
792.2 and 792.4	70	60
Farmington 796.5 and 798.2	70	60
<b>Within Ogden Terminal Limits</b>		
Switches, Cecil Junction.	15	15
Main track No. 1 and south leg of Wye Track between Bridge Jct. and Patterson Ave.	15	15
North leg of wye between 28th Street and Bridge Junction	10	10
Riverdale By-Pass track (Between East Riverdale and Bridge Jct.)	40	40
<b>Between Ogden and McCammon</b>		

LOCATION	MPH		LOCATION	MPH	
	PSGR	FRT		PSGR	FRT
Maximum speed 0.0 and 111.2	70	60	53.5 and 53.9	65	55
Between Mile Posts — Perry 19.2 and 20.9	70	55	Cornish 64.1 and 64.5	65	55
20.9 and 21.1	35	35	Weston 66.1 and 67.1	50	40
Brigham City 23.1 and 23.4	65	55	Coulam 82.7 and 83.0	50	40
Dewey 37.8 and 38.0	50	40	Swan Lake 85.6 and 87.5	65	55
41.0 and 42.0	65	55	90.2 and 90.4	55	45
42.0 and 44.6	50	40	92.3 and 93.9*(See Note)	65	55
Wheelon 44.6* and 46.4*(See Note)	12	12	Downey 99.4 and 99.6	60	50
46.4 and 47.2	30	30	Virginia 102.4 and 102.6	65	55
47.2 and 47.5*(See Note)	60	40	Arimo 107.4 and 107.7	65	55
47.5 and 49.0	35	35	110.8 and 111.4	45	35
Cache Junction 49.0 and 49.3	25	25			
49.3 and 51.4	50	40			

Note — Reduce Speed\* signs have been placed on left side of track.

UTAH DIVISION

UTAH DIVISION

UTAH DIVISION

WESTWARD			SECOND SUBDIVISION	EASTWARD				
STATION NUMBER	LENGTH OF SIDINGS FEET	FIRST CLASS 35 DAILY	Timetable No. 7			MILE POST	FIRST CLASS 36 DAILY	RULE 8(B)
			STATIONS					
			DN-R NORTH YARD YL	Freight Line	783.6		FPTY	
			GRANT TOWER YL		782.9		IP	
			WP-UP JUNCTION CP782 YL	Passenger Line	781.7		PX	
	6004		CP779		779.2		P	
9-1029		10.35PM	SALT LAKE CITY YL		782.8	A6.20AM	P	
			DRGW CROSSING YL		782.6		AP	
			DRGW CROSSING YL		782.4		AP	
9-1033	2640		INDUSTRIAL CENTER (SPUR-W) YL		779.8		P	
			CP779		779.2		PX	
9-1034	6004		BUENA VISTA		778.5		P	
9-1036			CENTENNIAL PARK (SPUR-E)		777.6		P	
9-1045	6155		D GARFIELD		768.2		P	
			K.C.C. CONN.		767.1		P	
9-1047			SMELTER CP766		766.4		PX	
9-1049	6015		LAKE POINT		764.5		P	
9-1057	6005		ERDA		756.2		P	
9-1061	2032		SHIELDS		752.2		P	
9-1065	6005		WARNER		747.7		PY	
9-1068	1440		BAUER (SPUR-E)		745.0		P	
9-1070	6410		STOCKTON		743.1		P	
9-1077	6010		ST. JOHN		736.2		P	
9-1081			CLOVER (SPUR-E)		732.8		PY	
9-1090	6960		FAUST		722.8		P	
9-1096	6013		PEHRSON		717.1		P	
9-1103	6717		LOFGREEN		710.6		P	
9-1109	5996		BOULTER		704.5		P	
9-1114	6005		TINTIC		698.0		P	
9-1121	6037		McINTYRE		691.9		P	
9-1128	6165		JERICO		685.4		P	
9-1138	6797		CHAMPLIN		675.5		P	
			LYNNDYL CP667 CP666 CP664		666.9 665.7 664.4		P PX P	
9-1147	6069		CLINE (SPUR-E)		661.2		P	
9-1152			STRONG		658.3		P	
9-1164	6071 9024	S12.45AM	D DELTA		650.0	S3.55	PY	
9-1173	5998		VAN		639.8		P	
9-1182	5991		CLEAR LAKE		631.2		P	
9-1198	5990		BLOOM		617.3		P	
9-1203	6078		CRUZ		609.8		P	
9-1214	6027		BLACK ROCK		599.5		P	
9-1223	5997		READ		589.9		P	
9-1228	5995		MURDOCK		584.7		P	
9-1236	11630	A2.00AM	DN-R MILFORD CP578 CP577		578.0 576.8	2.50AM	P PXY	
			(206.8)					

Note 2 to Rule 99 is in effect on Second Subdivision.

**CLEARANCE AND REGISTER REQUIREMENTS**

Trains to or from Provo Subdivision need not receive clearance at Lynndyl.

Trains to or from Fillmore Branch need not receive clearance at Delta.

All trains must receive clearance at Milford.

Conductors on Amtrak Nos. 35 and 36 will register at Milford with Train Register Ticket to be delivered to the operator who will register for the conductor.

Movements on IPP Spur are governed by Radio Block Clearance. See Special Rule 96 (RU-1).

UTAH DIVISION

**SPEED RESTRICTIONS — SECOND SUBDIVISION**

LOCATION	MPH	
	PSGR	FRT
Maximum speed between MP 779.2 and MP 678.0 MP 678.0 and MP 576.5	79	60
Between Mile Posts — Milford 576.2* and 576.5 (See Note)	50	35
576.5 Until engine has passed over hand operated switch (Old Frisco Lead)	20	20
Delta 655.8 and 656.4	70	80
Lynndyl (Sidings) Until engine passes over hand operated switches	20	20
Champlin 678.9 and 680.5 680.5 and 689.0	65	50
	60	45
Tintic 699.6 and 700.0 702.1 and 703.8	70	60
	70	60
Boulter 705.8 and 711.3 711.3 and 715.9	55	40
	55	45
Pehrson 719.6 and 721.0	60	50
St. John 742.1 and 744.1	50	40
Warner 754.2 and 757.1*	60	45
Erda 757.1* and 758.9 (See Note) 762.7 and 763.4	55	40
	65	55
Smelter When using No. 20 Turnouts at Smelter 767.2 and 770.6	35	35
	70	60
Buena Vista — via Freight Line 779.2 and 780.8 780.8 and 782.9	50	50
	20	20
Within Interlocking Limits: Grant Tower (except south leg of wye) Grant Tower — South leg of wye	15	15
	10	10
Buena Vista — via Passenger Line 779.2*** and DRGW crossing, MP 782.4	25	25
Over DRGW crossings MP 782.4 and MP 782.6	20	20
Between Ninth South Street and Passenger Station and between Fourth West and Fifth West Streets	12	12
Salt Lake City When shoving cars between Sixth North Street and Twenty First South Street		5
IPP Spur 0.0 and 8.9	25	25
Offsite siding	15	15
All other tracks	15	15

NOTE: — Reduce Speed\* signs placed to left of track.

\*\*\*Reduce speed sign governing eastward trains located at beginning of restriction.

UTAH DIVISION

WESTWARD			THIRD SUBDIVISION (MOUNTAIN TIME)	EASTWARD				
STATION NUMBER	LENGTH OF SIDINGS FEET	FIRST CLASS 35 Daily	Timetable No. 7			MILE POST	FIRST CLASS 36 Daily	RULE 6(B)
			STATIONS					
9-1236	6600	2.05AM	DN-R	MILFORD	CP577 CP575	576.8 575.1	A2.45AM	PXY
9-1241	6026			5.4				
9-1251	6002			UPTON		571.4		P
9-1262	5988			9.9				
9-1272	9101			THERMO		561.5		P
9-1281	6006			10.8				
9-1286	5981			LATIMER		550.7		P
9-1297	6016			8.9				
9-1303	6004			LUND		541.8		PY
9-1312	6008			10.1				
9-1319	6490			ZANE		531.7		P
9-1324	6013			5.5				
9-1328	6041			BERYL		526.2		P
9-1338	6516			10.0				
9-1341	2520			HEIST		516.2		P
9-1342	5812			6.0				
9-1349	15105			MODENA		510.2		PY
	6250 7830	s4.15		UVADA		501.1		P
9-1353	6079			4.6				
9-1358	5976			*CRESTLINE		496.5		P
9-1363	5976			6.0				
9-1368	6013			BROWN		489.6		P
9-1375	6275			5.4				
9-1379	7140			ACOMA		484.2		P
9-1384	5925			8.6				
9-1394	5872			ISLEN		475.6		P
9-1399	6068			3.6				
9-1405	6100			LITTLE SPRINGS		472.0		P
9-1410	5977			1.4				
9-1415	6645			RICHMOND		470.6		P
9-1420	6056			4.7				
9-1430	6066			ECCLES		464.5		P
9-1439	6102			D	CALIENTE	CP461 CP460 CP458	461.0 459.8 458.3	s12.15AM P PXY
9-1456	6282			5.2				
9-1459	1680			ETNA		454.8		P
9-1461	6072			4.9				
9-1466	6107			STINE		449.9		P
9-1468	600			4.7				
9-1470	1860			BOYD		445.2		P
9-1473	2460			6.8				
9-1474	6119			ELGIN		438.4		P
9-1479	A7.10AM			9.9				
				KYLE		434.5		P
				5.4				
				LEITH		429.1		P
				10.4				
				CARP		418.7		P
				6.3				
				VIGO		413.4		P
				5.4				
				GALT		408.0		P
				5.2				
				HOYA		402.8		P
				4.7				
				ROX		398.1		P
				9.9				
				FARRIER		393.0		P
				D	MOAPA		383.1	PY
				9.3				
				UTE		373.8		P
				10.6				
				DRY LAKE		363.2		P
				6.2				
				GARNET		357.0		P
				3.2				
				ARROLIME		353.8		P
				1.8				
				APEX FIBREBOARD (SPUR-W)		352.0		P
				5.3				
				DIKE		346.7		P
				2.1				
				LOVELL (SPUR-W)		344.6		P
				2.0				
				VALLEY (SPUR-E) NELLIS AIR BASE (SPUR-W)		342.6		P
				5.8				
				NEVADA INDUS PARK (SPUR-W)		340.0		P
				0.9				
				WANN (SPUR-E)		339.1		P
				4.8				
				DN-R	LAS VEGAS	YL	334.3	9.50PM FPY
				(242.5)				

\*Distance between MP493 and 494 = 850 Ft. Acct. line change.

Note 2 to Rule 99 is in effect on Third Subdivision.

**CLEARANCE AND REGISTER REQUIREMENTS**

Trains to or from Cedar City Branch at Lund will retain their identity and need not receive clearance at Lund.

Trains to or from Piche-Prince Branches need not receive clearance at Caliente.

Trains to or from Mead Lake Branch need not receive clearance at Moapa.

All trains must receive clearance at Milford.

Conductors on Amtrak Nos. 35 and 36 will register at Milford with Train Register Ticket to be delivered to the operator who will register for the conductor.

UTAH DIVISION  
SPEED RESTRICTIONS — THIRD SUBDIVISION

LOCATION	MPH	
	PSGR	FRT
Maximum Speed		
Between 334.3 and 393.9	79	60
393.9 and 500.0	70	50
500.0 and 576.2	70	70
Las Vegas Industrial Park spur on curves		5
Nevada Industrial Park spur MP 340.0 all movements on curves		5
Between Mile Posts — Las Vegas		
333.0 and 334.6	20	20
335.4 and 336.1	60	50
Dike		
348.3 and 351.1	45	35
Fibreboard Spur		20 20
Apex		
356.1 and 358.5	45	35
358.5 and 359.5	60	50
Ute		
379.1 and 379.6	60	50
379.6 and 380.9	65	55
Farrier		
393.9 and 394.2	60	45
394.2 and 395.9	35	35
397.5 and 398.6	40	35
Hoya		
403.7 and 418.0* (See Note)	35	30
418.0 and 419.7	40	40
Galt (siding) Until engine passes over hand operated switches		20 20
Carp (siding) Until engine passes over hand operated switches		20 20
425.4 and 427.9	55	45
427.9 and 428.2* (See Note)	55	40
428.2* and 430.0	55	45
Leith		
430.0 and 430.7	35	30
430.7 and 441.9	35	35
Elgin		
441.9 and 444.0	25	25
444.0 and 452.5	35	30
Stine		
452.5 and 455.2	35	35
458.4 and 460.0	50	40
Caliente		
460.0 and 461.2	40	35
461.2 and 461.7	30	25
461.7 and 463.9	40	35
Eccles (siding) Until engine passes over hand operated switches		20 20
463.9 and 469.1	55	45
469.1 and 470.7	25	25
470.7 and 475.0* (See Note)	20	20
Islen		
475.0 and 477.3	25	25
477.3 and 481.7	40	35
Acoma		
481.7 and 486.8	60	50

Note — Reduce Speed\* signs placed to left of track.

# UTAH DIVISION SPEED RESTRICTIONS — THIRD SUBDIVISION

LOCATION	MPH	PSGR	FRT
486.8 and 488.7	30		30
Brown-Crestline 488.7 and 489.9	50		40
489.9 and 498.0	60		50
Crestline (siding) Until engine passes over hand operated switches	20		20
Uvada 500.0 and 502.5	70		55
Milford Sidings — Until engine passes over hand operated switches	20		20
576.2* and 576.5 (See Note)	50		35
MP 576.5 — Until engine has passed over hand operated switch (Old Frisco Lead)	20		20

Note — Reduce Speed\* signs placed to left of track.

66	50	486.8 and 488.7
68	50	486.8 and 488.7
70	50	486.8 and 488.7
72	50	486.8 and 488.7
74	50	486.8 and 488.7
76	50	486.8 and 488.7
78	50	486.8 and 488.7
80	50	486.8 and 488.7
82	50	486.8 and 488.7
84	50	486.8 and 488.7
86	50	486.8 and 488.7
88	50	486.8 and 488.7
90	50	486.8 and 488.7
92	50	486.8 and 488.7
94	50	486.8 and 488.7
96	50	486.8 and 488.7
98	50	486.8 and 488.7
100	50	486.8 and 488.7
102	50	486.8 and 488.7
104	50	486.8 and 488.7
106	50	486.8 and 488.7
108	50	486.8 and 488.7
110	50	486.8 and 488.7
112	50	486.8 and 488.7
114	50	486.8 and 488.7
116	50	486.8 and 488.7
118	50	486.8 and 488.7
120	50	486.8 and 488.7
122	50	486.8 and 488.7
124	50	486.8 and 488.7
126	50	486.8 and 488.7
128	50	486.8 and 488.7
130	50	486.8 and 488.7
132	50	486.8 and 488.7
134	50	486.8 and 488.7
136	50	486.8 and 488.7
138	50	486.8 and 488.7
140	50	486.8 and 488.7
142	50	486.8 and 488.7
144	50	486.8 and 488.7
146	50	486.8 and 488.7
148	50	486.8 and 488.7
150	50	486.8 and 488.7
152	50	486.8 and 488.7
154	50	486.8 and 488.7
156	50	486.8 and 488.7
158	50	486.8 and 488.7
160	50	486.8 and 488.7
162	50	486.8 and 488.7
164	50	486.8 and 488.7
166	50	486.8 and 488.7
168	50	486.8 and 488.7
170	50	486.8 and 488.7
172	50	486.8 and 488.7
174	50	486.8 and 488.7
176	50	486.8 and 488.7
178	50	486.8 and 488.7
180	50	486.8 and 488.7
182	50	486.8 and 488.7
184	50	486.8 and 488.7
186	50	486.8 and 488.7
188	50	486.8 and 488.7
190	50	486.8 and 488.7
192	50	486.8 and 488.7
194	50	486.8 and 488.7
196	50	486.8 and 488.7
198	50	486.8 and 488.7
200	50	486.8 and 488.7

Note — Reduce Speed\* signs placed to left of track.

# UTAH DIVISION

STATION NUMBER	LENGTH OF TRACK	PROVO SUBDIVISION		STATIONS	MILE MARKERS
		EASTWARD	WESTWARD		
0-100	0.500			LYNDLE CROSS	P. 085.7, 086.2
0-101	0.500			MAR TOWER	P. 087.0
0-102	0.500			WALLEY	P. 088.0
0-103	0.500			SHARPE	P. 089.0
0-104	0.500			WALKER	P. 090.0
0-105	0.500			WALKER	P. 091.0
0-106	0.500			WALKER	P. 092.0
0-107	0.500			WALKER	P. 093.0
0-108	0.500			WALKER	P. 094.0
0-109	0.500			WALKER	P. 095.0
0-110	0.500			WALKER	P. 096.0
0-111	0.500			WALKER	P. 097.0
0-112	0.500			WALKER	P. 098.0
0-113	0.500			WALKER	P. 099.0
0-114	0.500			WALKER	P. 100.0
0-115	0.500			WALKER	P. 101.0
0-116	0.500			WALKER	P. 102.0
0-117	0.500			WALKER	P. 103.0
0-118	0.500			WALKER	P. 104.0
0-119	0.500			WALKER	P. 105.0
0-120	0.500			WALKER	P. 106.0
0-121	0.500			WALKER	P. 107.0
0-122	0.500			WALKER	P. 108.0
0-123	0.500			WALKER	P. 109.0
0-124	0.500			WALKER	P. 110.0
0-125	0.500			WALKER	P. 111.0
0-126	0.500			WALKER	P. 112.0
0-127	0.500			WALKER	P. 113.0
0-128	0.500			WALKER	P. 114.0
0-129	0.500			WALKER	P. 115.0
0-130	0.500			WALKER	P. 116.0
0-131	0.500			WALKER	P. 117.0
0-132	0.500			WALKER	P. 118.0
0-133	0.500			WALKER	P. 119.0
0-134	0.500			WALKER	P. 120.0
0-135	0.500			WALKER	P. 121.0
0-136	0.500			WALKER	P. 122.0
0-137	0.500			WALKER	P. 123.0
0-138	0.500			WALKER	P. 124.0
0-139	0.500			WALKER	P. 125.0
0-140	0.500			WALKER	P. 126.0
0-141	0.500			WALKER	P. 127.0
0-142	0.500			WALKER	P. 128.0
0-143	0.500			WALKER	P. 129.0
0-144	0.500			WALKER	P. 130.0
0-145	0.500			WALKER	P. 131.0
0-146	0.500			WALKER	P. 132.0
0-147	0.500			WALKER	P. 133.0
0-148	0.500			WALKER	P. 134.0
0-149	0.500			WALKER	P. 135.0
0-150	0.500			WALKER	P. 136.0
0-151	0.500			WALKER	P. 137.0
0-152	0.500			WALKER	P. 138.0
0-153	0.500			WALKER	P. 139.0
0-154	0.500			WALKER	P. 140.0
0-155	0.500			WALKER	P. 141.0
0-156	0.500			WALKER	P. 142.0
0-157	0.500			WALKER	P. 143.0
0-158	0.500			WALKER	P. 144.0
0-159	0.500			WALKER	P. 145.0
0-160	0.500			WALKER	P. 146.0
0-161	0.500			WALKER	P. 147.0
0-162	0.500			WALKER	P. 148.0
0-163	0.500			WALKER	P. 149.0
0-164	0.500			WALKER	P. 150.0
0-165	0.500			WALKER	P. 151.0
0-166	0.500			WALKER	P. 152.0
0-167	0.500			WALKER	P. 153.0
0-168	0.500			WALKER	P. 154.0
0-169	0.500			WALKER	P. 155.0
0-170	0.500			WALKER	P. 156.0
0-171	0.500			WALKER	P. 157.0
0-172	0.500			WALKER	P. 158.0
0-173	0.500			WALKER	P. 159.0
0-174	0.500			WALKER	P. 160.0
0-175	0.500			WALKER	P. 161.0
0-176	0.500			WALKER	P. 162.0
0-177	0.500			WALKER	P. 163.0
0-178	0.500			WALKER	P. 164.0
0-179	0.500			WALKER	P. 165.0
0-180	0.500			WALKER	P. 166.0
0-181	0.500			WALKER	P. 167.0
0-182	0.500			WALKER	P. 168.0
0-183	0.500			WALKER	P. 169.0
0-184	0.500			WALKER	P. 170.0
0-185	0.500			WALKER	P. 171.0
0-186	0.500			WALKER	P. 172.0
0-187	0.500			WALKER	P. 173.0
0-188	0.500			WALKER	P. 174.0
0-189	0.500			WALKER	P. 175.0
0-190	0.500			WALKER	P. 176.0
0-191	0.500			WALKER	P. 177.0
0-192	0.500			WALKER	P. 178.0
0-193	0.500			WALKER	P. 179.0
0-194	0.500			WALKER	P. 180.0
0-195	0.500			WALKER	P. 181.0
0-196	0.500			WALKER	P. 182.0
0-197	0.500			WALKER	P. 183.0
0-198	0.500			WALKER	P. 184.0
0-199	0.500			WALKER	P. 185.0
0-200	0.500			WALKER	P. 186.0

UTAH DIVISION  
SPEED RESTRICTIONS — THIRD SUBDIVISION

Note — Reduce Speed\* signs placed to left of track.

UTAH DIVISION

UTAH DIVISION

UTAH DIVISION

WESTWARD		PROVO SUBDIVISION			EASTWARD	
STATION NUMBER	LENGTH OF SIDINGS	Timetable No. 7			MILE POST	RULE 6(B)
	FEET	STATIONS				
		DN-R	NORTH YARD	YL	783.6	FPTY
			GRANT TOWER	YL	P-800.1	IP
			DRGW CROSSING	YL	P-797.9	A
	4020		OFFICER	YL	P-797.4	
	900		BURTON	YL	P-796.8	
			DRGW CROSSING	YL	P-796.6	
5-1034	3956		HUSLERS	YL	P-795.6	
5-1036	2227		MURRAY	YL	P-793.0	
5-1037	1714		PALLAS	YL	P-791.7	
5-1039			ATWOOD (SPUR-E)	YL	P-790.5	
5-1042	5072		SANDY	YL	P-787.0	
5-1046	2760		DRAPER		P-782.6	
5-1053	3667		MOUNT		P-775.8	
5-1058	3657		CUTLER		P-771.1	
5-1059	2047		LEHI		P-769.3	
5-1062	150		AMERICAN FORK (SPUR-E)		P-766.4	
5-1065	4002		PLEASANT GROVE	YL	P-763.0	
5-1067	1500		HARDY (SPUR-W)	YL	P-761.8	
5-1069	240		BONNIE (SPUR-W)	YL	P-760.3	
5-1070	840		BUNKER (SPUR-E)	YL	P-759.9	
5-1071	720		CLYDE (SPUR-W)	YL	P-759.4	
5-1072	5975	CTC	GENEVA	YL	P-757.9	P
			DRGW CROSSING	YL	P-757.3	A
5-1075			GATEX (SPUR-E)	YL	P-756.1	
5-1076		DN-R	PROVO	YL	P-752.7	FPTY
			CPP749	YL	P-748.9	P
5-1085	1463	CTC	SPANISH FORK (SPUR E-W)		P-744.4	
5-1092	5420		PAYSON		P-736.3	P
5-1107	6129		STARR		P-722.2	P
5-1118	6108		NEPHI		P-711.5	P
5-1128	13420		SHARP		P-700.6	P
5-1133	6135		JUAB		P-696.0	P
5-1148	6138		PARLEY		P-680.7	P
P-1153	3092		MARTMAR		P-676.1	
9-1147	6930		LYNN DYL CP666		P-665.7	PX
				(135.1)		

Note 2 to Rule 99 is in effect on Provo Subdivision. ABS is in effect between MPP-798.5 and MPP-797.2.

On single track, except in CTC territory, eastward trains are superior to trains of the same class in the opposite direction. See Rule 72.

Provo Subdivision yard limits are continuous from MP P-800.1 to MP P-786.35 and from MP P-764.0 to MP P-748.9.

**CLEARANCE REQUIREMENTS**

Trains to or from Second Subdivision need not receive clearance at Lyndyl.

Westward Provo Subdivision trains must receive authority from train dispatcher to leave North Yard.

Westward Provo Subdivision trains must receive authority from train dispatcher or Provo yardmaster before entering yard limits at Pleasant Grove MP P-764.0.

Eastward Provo Subdivision trains must receive authority from train dispatcher to enter North Yard before entering yard limits at Sandy MP P-786.35.

UTAH DIVISION

**SPEED RESTRICTIONS — PROVO SUBDIVISION**

LOCATION	MPH
Maximum Speed P-665.7 and P-800.1	40
Maximum speed in CTC territory between Geneva and Provo (Yard Limits)	40
Between Mile Posts — Lyndyl P-665.8 and P-666.3	30
P-666.3 and P-667.2	35
P-674.8 and P-676.4	35
P-676.4 and P-686.2	30
Parley siding	20
P-691.8 and P-692.6	30
P-692.6 and P-694.4	35
Sharp siding until engine passes over hand operated switches	20
Nephi City Limits between P-710.0 and P-711.8** (See Note)	30
P-732.6 and P-733.5	30
Star siding until engine passes over hand operated switches	20
Provo P-752.8 and P-753.4	20
P753.4 and P-755.0	30
Geneva P-757.37 West Switch Over Road Crossings in Steel Plant	20 15
P-765.6 and P-767.5	35
Lehi City Limits, between P-768.7 and P-771.1	30
Sugar Factory Trackage west of stockyards	5
Cutler P-773.4 and P-777.6	30
P-777.6 and P-778.0	20
P-778.0 and P-782.7	35
Atwood Midvale Smelter Trackage	12
P-798.5 and P-797.2	20
Salt Lake City When shoving cars between Sixth North and Twenty First South Streets	5
Between Second South and Ninth South Streets	12

Note — Resume Speed\*\* signs placed to left of track.

## UTAH DIVISION BRANCHES

WESTWARD		FILLMORE BRANCH		EASTWARD	
STATION NUMBER	LENGTH OF SIDINGS	Timetable No. 7		MILE POST	RULE 6(B)
	FEET	STATIONS			
9-1164	6071 9024	D	DELTA 21.7	0.0	PY
281-22	495		GREENWOOD (SPUR-E) 10.3	21.7	
281-32			FILLMORE (32.0)	32.0	Y

WESTWARD		CEDAR CITY BRANCH		EASTWARD	
STATION NUMBER	LENGTH OF SIDINGS	Timetable No. 7		MILE POST	RULE 6(B)
	FEET	STATIONS			
9-1272	9101		LUND YL 20.3	0.0	PY
283-21		D	IRON SPRINGS YL 9.6	20.3	PY
	2640		STOCK YARDS (SPUR-W) 1.9	29.9	
283-33		D	CEDAR CITY YL (31.8)	31.8	

WESTWARD		IRON MOUNTAIN BRANCH		EASTWARD	
STATION NUMBER	LENGTH OF SIDINGS	Timetable No. 7		MILE POST	RULE 6(B)
	FEET	STATIONS			
283-21		D	IRON SPRINGS YL 4.5	0.0	PY
284-04			DESERT MOUND 6.	4.5	
284-11			COMSTOCK 3.8	10.9	Y
284-15			IRON MOUNTAIN YL (14.7)	14.7	

WESTWARD		PIOCHE-PRINCE BRANCHES		EASTWARD	
STATION NUMBER	LENGTH OF SIDINGS	Timetable No. 7		MILE POST	RULE 6(B)
	FEET	STATIONS			
9-1353	11150	D	CALIENTE 14.5	0.0	PY
285-15	1460		PANACA 18.2	14.5	
285-33			PIOCHE 6.5	32.7	Y
286-07			CASELTON 2.1	6.5	
286-09	179		PRINCE (41.3)	8.6	

## UTAH DIVISION BRANCHES

WESTWARD		MEAD LAKE BRANCH		EASTWARD	
STATION NUMBER	LENGTH OF SIDINGS	Timetable No. 7		MILE POST	RULE 6(B)
	FEET	STATIONS			
9-1430	6066	D	MOAPA YL 3.3	0.0	PY
287-03	1020		ARROWHEAD (SPUR-W) 6.2	3.3	
287-10	240		AMBER (SPUR-E) 0.7	9.5	
287-10	525		LOGANDALE 3.5	10.2	
287-14	1260		GLASSAND (SPUR-W) 2.9	13.7	
287-16			NEPAC 0.1	16.6	
287-17			MEAD LAKE (16.7)	16.7	Y

### CLEARANCE REQUIREMENTS

Trains to or from Third Subdivision need not receive clearance at Lund, Caliente or Moapa.

Movements on Pioche-Prince Branches are governed by staff system. Staff located in staff-waybill box 500 feet west of the stem of wye switch. See Special Rule 300(R).

Movements on Mead Lake Branch are governed by staff system. Staff located in staff box 500 feet west of stem of wye at Moapa. See Special Rule 300(R).

Movements on Cedar City Branch are governed by radio block clearance. See Special Rule 96 (RU-2).

Movements on Iron Mountain Branch are governed by radio block clearance. See Special Rule 96 (RU-3).

Movements on Fillmore Branch are governed by staff system. Staff is located in staff box at CTC phone at center Delta. See Special Rule 300(R).

### SPEED RESTRICTIONS

LOCATION	MPH
<b>Fillmore Branch</b>	
Maximum Speed	25
(All trains and engines must move prepared to stop at MP 18.5 if track is obstructed with drifting sand at that point.)	
<b>Cedar City Branch</b>	
Maximum Speed	40
23.0 and 29.0	20
Cedar City yard tracks	10
<b>Iron Mountain Branch</b>	
Maximum Speed	25
0.0 and 1.2	20
10.1 AND 14.5	15
<b>Pioche Branch</b>	
Maximum Speed	25
17.0 and 22.1	10
22.1 and 24.6	20
24.6 and 25.0	10
25.0 and 25.3	20
30.4 and 30.6	15
32.3 and end of track	10
<b>Caselton Spur</b>	
Maximum Speed	10
<b>Prince Branch</b>	
Maximum Speed	10
7.5 and 8.7	5
<b>Mead Lake Branch</b>	
Maximum Speed	25
1.6 and 2.3	20
5.0 and 6.7	10
7.0 and 9.0	20
<b>Fibreboard Spur</b>	
Maximum Speed	20

20-6-V-D-TC

UTAH DIVISION

UTAH DIVISION BRANCHES

WESTWARD		CACHE VALLEY BRANCH		EASTWARD	
STATION NUMBER	LENGTH OF SIDINGS	Timetable No. 7		MILE POST	RULE 6(B)
	FEET	STATIONS			
99-049	5300 3319		CACHE JCT. YL	0.0	PY
272-09	1883		MENDON	8.6	
272-14	1023		WELLSVILLE	13.8	
272-18	1224		HYRUM	17.6	
272-20	671		HOLT	20.2	
272-22	5280		SUGAR FACTORY (SPUR-E)	21.7	
272-24	2311	D-R	LOGAN	24.1	Y
272-32	911		SMITHFIELD	31.5	
272-37	1692		RICHMOND	37.4	
272-42	7700		PRESTO (SPUR-W)	41.5	
272-44	1699		FRANKLIN	43.6	
272-48	1301		WHITNEY	48.1	
272-51	1319		PRESTON	50.8	Y
			(50.8)		

WESTWARD		MALAD BRANCH		EASTWARD	
STATION NUMBER	LENGTH OF SIDINGS	Timetable No. 7		MILE POST	RULE 6(B)
	FEET	STATIONS			
99-021	6519	D-R	BRIGHAM CITY YL	0.0	PY
269-06	2643		CORINNE	5.5	
269-12	1469		FORD	11.5	
269-14	1457		CROPLEY	13.7	
269-18	2409		TREMONTON	17.8	
269-20	1147		GARLAND	19.7	Y
269-31			NUCOR	31.0	
269-52	1091	D	MALAD	51.5	Y
			(51.5)		

WESTWARD		SYRACUSE BRANCH		EASTWARD	
STATION NUMBER	LENGTH OF SIDINGS	Timetable No. 7		MILE POST	RULE 6(B)
	FEET	STATIONS			
9-1002			CLEARFIELD YL	0.0	PXY
			DRGW CROSSING YL	0.3	IP
		DN-R	FREEPORT YL	0.6	PY
266-02			BARNES YL	2.1	
			(2.1)		

Yard limits are continuous from Clearfield to Barnes.

UTAH DIVISION BRANCHES

WESTWARD		LITTLE MOUNTAIN BRANCH		EASTWARD	
STATION NUMBER	LENGTH OF SIDINGS	Timetable No. 7		MILE POST	RULE 6(B)
	FEET	STATIONS			
			LITTLE MOUNTAIN JCT.	0.0	PY
263-14			LITTLE MOUNTAIN	13.8	
			(13.8)		

Movements on Little Mountain Branch are governed by staff system. Staff is located in staff box near stem of wye, Hot Springs. See Special Rule 300(R).

WESTWARD		HILL FIELD BRANCH		EASTWARD	
STATION NUMBER	LENGTH OF SIDINGS	Timetable No. 7		MILE POST	RULE 6(B)
	FEET	STATIONS			
9-0993		DN-R	OGDEN YL	0.0	
151-02	655		ORCHARD (SPUR-W) YL	2.6	
151-03	855		COZYDALE (SPUR-E) YL	3.4	
151-04	335		ROY (SPUR-W) YL	4.2	
151-06			ARSENAL YL	6.7	
			END OF TRACK YL	6.8	
			(6.8)		

On Hill Field Branch, yard limits are continuous from Ogden Junction, to and including End of Track MP 6.8.

WESTWARD		EVONA BRANCH		EASTWARD	
STATION NUMBER	LENGTH OF SIDINGS	Timetable No. 7		MILE POST	RULE 6(B)
	FEET	STATIONS			
9-0993		DN-R	OGDEN YL	0.0	FPYT
2-6701			EVONA (SPUR-E) YL	0.7	
2-6701			RELICO (SPUR-E) YL	1.0	
			END OF BRANCH YL	1.6	
			(1.6)		

On Evona Branch, yard limits are continuous from Ogden to and including End of Branch, MP 1.6

On First Subdivision Branches, Westward trains are superior to trains of the same class in the opposite direction. — See Rule 72.

SPEED RESTRICTIONS

LOCATION	MPH
Between Mile Posts — Cache Valley Branch Maximum Speed	40
7.5 and 9.0	35
13.6 and 13.9	15
13.9 and 17.7	35
17.7 and 18.0	15
18.0 and 24.0	35
Logan Anderson Coach Spur	4
25.6 and 25.7	35
31.1 and 32.6	35
37.4 and 39.9	35
42.9 and 44.0	25
44.6 and 51.1	35

**SPEED RESTRICTIONS CONT.**

LOCATION	MPH
<b>Malad Branch</b>	
Maximum Speed	40
1.0 and 1.5	30
3.8 and 3.9	30
5.2 and 6.5	30
11.7 and 12.1	30
27.0 and 27.9	30
29.3 and 29.9	30
34.9 and 35.1	30
42.4 and 42.7	30
48.4 and 50.2	30
<b>Syracuse Branch</b>	
Maximum Speed	10
<b>Clearfield</b>	
Freeport Center Area	10
Freeport Center and Clearfield Wye Tracks	8
<b>Little Mountain Branch</b>	
Maximum Speed	40
0.0* and 0.4 (See Note)	15
1.5 and 1.7	25
3.5 and 3.8	25
14.3 and 14.4* (See Note)	15
<b>Hill Field Branch</b>	
Maximum Speed	15
<b>Between Mile Posts —</b>	
4.4 and 4.8	10

Note — Speed\* restriction signs located at point of restriction.

MILE POST	LOCATION	RESTRICTION
4.4	Between Mile Posts	10
4.8	Between Mile Posts	10
1.0	Malad Branch	30
1.5	Malad Branch	30
3.8	Malad Branch	30
3.9	Malad Branch	30
5.2	Malad Branch	30
6.5	Malad Branch	30
11.7	Malad Branch	30
12.1	Malad Branch	30
27.0	Malad Branch	30
27.9	Malad Branch	30
29.3	Malad Branch	30
29.9	Malad Branch	30
34.9	Malad Branch	30
35.1	Malad Branch	30
42.4	Malad Branch	30
42.7	Malad Branch	30
48.4	Malad Branch	30
50.2	Malad Branch	30
0.0	Little Mountain Branch	15
0.4	Little Mountain Branch	15
1.5	Little Mountain Branch	25
1.7	Little Mountain Branch	25
3.5	Little Mountain Branch	25
3.8	Little Mountain Branch	25
14.3	Little Mountain Branch	15
14.4	Little Mountain Branch	15



UNIT DIVISION

UNIT DIVISION



**UNION PACIFIC RAILROAD**  
**SOUTH CENTRAL DISTRICT**  
**CALIFORNIA DIVISION**

SCALE OF MILES

OFFICE OF CHIEF ENGINEER - OMAHA, NEBR.  
 C. E. DRAWING NO. 82745

CALIFORNIA DIVISION

CALIFORNIA DIVISION

CALIFORNIA DIVISION

WESTWARD			FIRST SUBDIVISION (PACIFIC TIME)			EASTWARD		
STATION NUMBER	LENGTH OF SIDINGS FEET	FIRST CLASS 35 Daily	Timetable No. 7			MILE POST	FIRST CLASS 36 Daily	RULE 8(B)
			STATIONS					
9-1479		6.25AM	DN-R	LAS VEGAS	YL	334.3	A8.35PM	FPY
				CP 330		330.5		PX
				CP 328		328.6		PX
9-1486	3403			BOULDER JCT.		327.4		PY
				CP 326		326.4		PX
9-1490	6480			ARDEN		322.4		PY
9-1491				BLUE DIAMOND SPUR		321.8		P
9-1498	6288			SLOAN		314.8		P
9-1504	5690			ERIE		309.3		P
9-1512	5730			JERAN		301.3		P
9-1517	5791			BORAX		296.4		P
9-1526	6116			CALADA		287.6		P
9-1535	5774			NIPTON		277.5		P
9-1541	5769			MOORE		272.4		P
9-1545	5761			IVANPAH		267.4		P
9-1550	5760			BRANT		263.2		P
9-1555	6062			JOSHUA		257.9		P
9-1559	6271 6355			CIMA		254.0		PY
9-1563	5667			CHASE		250.4		P
9-1566	5723			ELORA		247.3		P
9-1570	5781			DAWES		243.3		P
9-1574	5788			HAYDEN		239.3		P
9-1577	9191 9191			KELSO		235.4		P
9-1587	5757			KERENS		226.1		P
9-1595	6100			SANDS		218.0		P
9-1601	5758			BALCH		211.6		P
9-1609	5765			CRUCERO		203.5		P
9-1616	6198			BASIN		197.0		P
9-1621	640			AFTON (SPUR-E) CP 192		191.8		P
9-1626	6116			DUNN		187.4		P
9-1631	5718			FIELD		182.3		P
9-1635	5771			MANIX		177.5		P
9-1645				TOOMEY CP 168		168.0		PX
				CP 164 YL		163.9		PX
				DN-R YERMO YL		162.0		FP XY
				(171.2)				

Note 2 to Rule 99 is in effect on First Subdivision.

**CLEARANCE REQUIREMENTS**

All trains must receive clearance at Yermo.

Conductors on run-through trains will register at Yermo with register ticket which must include all delays encountered, and train orders and clearances will be handed up to rear end crew by operator.

CALIFORNIA DIVISION  
SPEED RESTRICTIONS — FIRST SUBDIVISION

LOCATION	MPH P8GR	FRT
Maximum Speed		
Between 163.1 and 309.3	79	70
Between 309.3 and 334.3	79	60
Between Mile Posts — Yermo		
162.0 until engine has passed over hand operated switch	20	20
Toomey Running Track (Between East Yermo and Toomey)	40	40
Field		
186.1 and 188.4	70	60
Dunn		
188.4 and 191.8	55	45
191.8 and 194.1	50	40
194.1 and 196.2	55	45
230.9 and 231.2	70	60
Kelso		
246.5 and 246.7	45	45
251.3 and 254.4	45	45
Cima		
254.0 and 236.0		
Westward freight trains not required to use retainers per Special Rule 1042(RC)		25
Westward freight trains being controlled exclusively with dyanmic brake		35
Westward passenger trains handled by diesel locomotive with dynamic brake in operation; diesel locomotive running light with dynamic brake in operation.	45	45
Erie		
309.3* and 309.8** (See Note)	70	60
311.7 and 312.5	50	40
Sloan		
314.6** and 317.1 (See Note)	40	30
318.5 and 319.7	40	30
319.7 and 321.1	65	55
Arden		
Las Vegas North Running Track (Between CP 326.0 and MP 332.6)	40	40
Las Vegas		
333.0 and 334.6	20	20
334.6 and 336.1	60	50
Blue Diamond Spur		
Maximum Speed		25
0.02 and 0.10		20
1.4 and 1.6		20
3.5 and 4.3		20
5.1 and 5.2		20
6.3 and 6.6		20
8.7 and 9.0		12
9.8 and 10.7		12

Note — Reduce Speed\* or Resume Speed\*\* signs placed to left of track.

CALIFORNIA DIVISION

WESTWARD			SECOND SUBDIVISION		EASTWARD		
STATION NUMBER	LENGTH OF SIDINGS FEET	FIRST CLASS 35 DAILY	Timetable No. 7		MILE POST	FIRST CLASS 36 DAILY	RULE (B)
			STATIONS				
			DN-R	YERMO YL	162.0		FPY
9-1650			CTC	CP 161 YL	160.5		P
9-1654		9.50AM		DAGGETT CP 159	158.5	5.30PM	
9-1663		A10.00AM		BARSTOW	150.1	5.20PM	
9-1746				SAN BERNARDINO	67.3		
9-1749				COLTON	64.5		
				RIVERSIDE JCT. CP 58	58.1		P
9-1755			D	RIVERSIDE	57.5		P
9-1759	6095			STREETER	53.8		P
9-1760	5476			ARLINGTON	53.2		P
9-1765	5986			PEDLEY	48.2		PY
9-1767	5952		D	MIRA LOMA	45.2		P
9-1769				CHAMPAGNE (SPUR-W)	43.3		
9-1773	2258			BALLOU	40.4		
				CP38	38.4		P
				SP CROSSING	38.1		IP
9-1775				ONTARIO	37.8		P
9-1777	5968		CTC	MONTCLAIR	36.1		P
				SP CROSSING CP 33	33.0		
9-1781				POMONA	31.9		P
9-1784	5791			SPORA	29.0		P
9-1789	6032			WALNUT	24.8		P
				PUENTE JCT. CP 18	17.8		P
9-1796	5937		D	CITY OF INDUSTRY	16.9		P
				BARTOLO CP 11	11.3		P
9-1802				WHITTIER JCT. CP 10	10.9		P
9-1803	5918			PICO-RIVERA	10.5		P
9-1804	3214			MONTEBELLO	8.1		P
				CP8 YL	7.7		P
				CP7 YL	7.2		P
9-1806			DN	EAST LOS ANGELES YL	5.9		P
9-1809			R	EAST YARD YL	4.2		FPY
9-1810				DOWNEY ROAD CP 3 YL	2.8		P
			CTC	NINTH ST. JCT. YL	1.7		P
				FIRST ST. CP 0 YL	0.0		P
9-1812				PASADENA JCT. YL			P
				ATSF CROSSING (Mission Tower)			P
9-1813				LOS ANGELES (Union Station)			
				(164.8)			

Note 2 to Rule 99 is in effect on Second Subdivision.

CALIFORNIA DIVISION  
CLEARANCE REQUIREMENTS

All trains must receive clearance at Yermo.  
 Trains originating at Los Angeles Union Station need not receive clearance at LAUPT but must receive clearance at East Los Angeles.  
 Trains from Anaheim Branch need not receive clearance at Whittier Jct.  
 Eastward Union Pacific trains which will operate via ATSF must secure ATSF clearance card at Union Pacific East Yard, Los Angeles.  
 Westward Union Pacific trains which will operate via ATSF must secure ATSF clearance card at Yermo.  
 Union Pacific trains originating at Colton and operating on ATSF tracks must secure ATSF clearance card at Colton and must secure UP clearance on UP tracks west of Riverside.  
 Between Daggett and Riverside Jct. trains are governed by Operating Rules, Timetable and Special Instructions of ATSF Ry.  
 Between Los Angeles and LAUPT CO. terminal limits 200 ft. west of ATSF Crossing (Mission Tower) trains and engines are governed by Operating Rules and Special Instructions of LAUPT.  
 Between Pasadena Jct. and Los Angeles movement of trains and engines are governed by interlocking signals.

SPEED RESTRICTIONS — SECOND SUBDIVISION

LOCATION	MPH	PSGR	FRT
Maximum Speed Between			
0.0 and 58.1	75	60	
158.5 and 163.1	75	60	
Between Mile Posts —			
Los Angeles Union Passenger Terminal			
Los Angeles River Bridge and MP 0.0	15	15	
5.7 and 58.1 freight trains averaging in excess of 85 tons per operative brake			40
Ninth Street Jct.			
0.0 and 1.6	35	35	
1.6 and 7.7	20	20	
East Yard			
Eastward Trains — Track 3			
5.7 and 7.7	40	40	
7.7 and 10.2	65	60	
Pico-Rivera			
10.2* and 11.3 (See Note)	65	55	
11.3 and 38.1	65	60	
Ontario			
38.1 and 38.4 Over SP Crossing	45	45	
38.4 and 40.0	65	60	
Pedley			
49.9 and 50.8	70	60	
51.8 and 53.4	65	55	
Streeter			
53.4 and 55.4	50	50	
55.4 and 57.0	45	45	
Riverside			
57.0 and 58.1	20	20	
Daggett			
158.8 and 159.0	30	30	
Yermo			
162.0 until engine has passed over hand operated switch	20	20	

Note — Reduce Speed\* signs placed to left of track.

# CALIFORNIA DIVISION BRANCHES

Following branches are completely within yard limits:

San Pedro Branch  
 Anaheim Branch  
 Crestmore Branch  
 Glendale Branch  
 Lakewood Branch  
 Pasadena Branch  
 Boulder City Branch

WESTWARD		SAN PEDRO BRANCH		EASTWARD	
STATION NUMBER	LENGTH OF SIDINGS	Timetable No. 7		MILE POST	RULE 6(B)
	FEET	STATIONS			
9-1809		R	EAST YARD YL		FPY
295-00		DN	HOBART ATSF Crossing YL	3.1	IP
			L.A. JCT. RY. CROSSING YL	3.6	I
295-04	3739		SP CROSSING YL	5.1	A
			BELL YL	5.4	
			SP CROSSING YL	7.4	A
295-07	716		WORKMAN YL	9.3	
			SP CROSSING YL	11.2	A
295-10	5915	R	PARAMOUNT YL	12.5	
295-11			RIOCO YL	13.8	
295-12			DOUGLAS JCT. YL	14.6	
			SP CROSSING YL	17.4	A
295-15			CARSON YL	17.7	
295-16	5807		MANUEL YL	19.2	
			THENARD CONN. YL	21.6	
			SP CROSSING YL	21.7	
295-19		D	MEAD TRANSFER YL	22.1	P
			HENRY FORD BLVD. DRAWBRIDGE YL	23.2	I
295-21			TERMINAL ISLAND YL	24.2	PY
295-23			EAST SAN PEDRO YL	25.3	
			(22.2)		

Maintenance of Way Rule 99(J) does not apply.

## SPEED RESTRICTIONS

LOCATION	MPH
<b>San Pedro Branch</b>	
Maximum Speed	20
Lead known as Consolidated Lumber Company track:	
On straight track	10
On curves	5
Thenard connecting track	5
Between Mile Posts —	
21.8 and 23.8	10
23.6 and 25.2	5
Maximum speed all tracks Mead yard.	10

WESTWARD		ANAHEIM BRANCH		EASTWARD	
STATION NUMBER	LENGTH OF SIDINGS	Timetable No. 7		MILE POST	RULE 6(B)
	FEET	STATIONS			
9-1802			WHITTIER JCT. YL	0.0	P
			SP CROSSING YL	0.1	
292-02	1037		WHITTIER YL	2.4	
			COLIMA JCT. YL	5.2	
292-10			LA HABRA YL	9.6	
			FULLERTON JCT. YL	10.5	
			ATSF CROSSING YL	15.5	I
292-17	585	D	FULLERTON YL	17.3	
292-20	1056		ANAHEIM YL	19.9	
			(20.4)		

Between Colima Jct. and Fullerton Jct. trains and engines are governed by Operating Rules, Timetable and Special Instructions of Southern Pacific Co.

## SPEED RESTRICTIONS — ANAHEIM BRANCH

LOCATION	MPH
Maximum Speed	20
Between Mile Posts —	
0.2 and 0.12	5
0.2 and 0.3	10
0.3 and 2.8	15
5.1 and 5.2	10
10.5 and 11.0	5
11.0 and 15.6	15
16.8 and 17.7	15
18.5 and 20.4	10

## CALIFORNIA DIVISION BRANCHES

WESTWARD		CRESTMORE BRANCH		EASTWARD			
STATION NUMBER	LENGTH OF SIDINGS	Timetable No. 7				MILE POST	RULE 6(B)
	FEET	STATIONS					
9-1765	5986	PEDLEY	YL	0.0	PY		
290-07		CRESTMORE	YL	6.8			
		(6.9)					

WESTWARD		GLENDALE BRANCH		EASTWARD			
STATION NUMBER	LENGTH OF SIDINGS	Timetable No. 7				MILE POST	RULE 6(B)
	FEET	STATIONS					
293-01		GLENDALE JCT.	YL	0.0			
294-01		ARROYO JCT.	YL	3.0			
294-04		GLENDALE	YL	3.5			
294-04		FOREST LAWN	YL	4.2			
		(4.2)					

WESTWARD		LAKEWOOD BRANCH		EASTWARD			
STATION NUMBER	LENGTH OF SIDINGS	Timetable No. 7				MILE POST	RULE 6(B)
	FEET	STATIONS					
295-12		DOUGLAS JCT.	YL	0.0			
296-02	3300	LAKEWOOD	YL	1.6	Y		
		END OF TRACK	YL	2.8			
		(2.8)					

WESTWARD		PASADENA BRANCH		EASTWARD			
STATION NUMBER	LENGTH OF SIDINGS	Timetable No. 7				MILE POST	RULE 6(B)
	FEET	STATIONS					
9-1812		PASADENA JCT.	YL	0.9			
293-01		GLENDALE JCT.	YL	1.6			
293-02		AVENUE 33	YL	2.7			
		(1.8)					

WESTWARD		BOULDER CITY BRANCH		EASTWARD			
STATION NUMBER	LENGTH OF SIDINGS	Timetable No. 7				MILE POST	RULE 6(B)
	FEET	STATIONS					
9-1486		BOULDER JCT.	YL	0.0	PY		
288-10	2527	D HENDERSON	YL	9.9			
288-22		BOULDER CITY	YL	22.2	Y		
		(22.4)					

## CALIFORNIA DIVISION BRANCHES

On single track, except in CTC territory, eastward trains are superior to trains of the same class in the opposite direction. See Rule 72.

### CLEARANCE REQUIREMENTS

Trains to or from First Subdivision need not receive clearance at Boulder Jct.

### SPEED RESTRICTIONS

LOCATION	MPH
<b>Crestmore Branch</b>	
Maximum Speed	10
<b>Glendale Branch</b>	
Maximum Speed	20
3.06 and 4.2	10
Trains and engines are governed by SP Co. timetable and rules while using SP Co. tracks between Avenue 18 (MP 0.36) and Arroyo Jct.	
<b>Lakewood Branch</b>	
Maximum Speed	20
MP 0.6 (Over Del Amo Blvd.)	10
MP 2.5 (Over Wardlow Road)	10
<b>Pasadena Branch</b>	
Maximum Speed	20
MP 1.6 and 2.7	5
<b>Boulder City Branch</b>	
Maximum Speed	20
Between East and West Leg Wye	15

# NORTHWESTERN DISTRICT

**A. L. SHOENER**  
General Manager

**L. B. MASKILL**  
General Superintendent

## IDAHO DIVISION

<b>A. L. O'NEILL</b>	<b>Superintendent</b>	<b>Pocatello, Idaho</b>
P. C. WYATT	Assistant Superintendent	Pocatello, Idaho
L. J. SCHREIBER	Terminal Superintendent	Pocatello, Idaho
R. V. DOYLE	Assistant Terminal Superintendent	Pocatello, Idaho
T. K. SHUMWAY	Terminal Trainmaster	Pocatello, Idaho
G. C. PHILLIPS	Terminal Trainmaster	Pocatello, Idaho
D. L. LEWIS	Terminal Trainmaster	Pocatello, Idaho
R. E. RILEY	Trainmaster	Burley, Idaho
R. B. FISKE	Trainmaster	Kemmerer, Wyo.
V. M. TORRES	Trainmaster	Nampa, Idaho
R. F. STEPHAN	Trainmaster	Nampa, Idaho
D. L. SULLIVAN	Terminal Superintendent	Nampa, Idaho
M. G. TRANSTRUM	Trainmaster	Idaho Falls, Idaho
T. D. WELLS	Trainmaster	Soda Springs, Idaho
R. T. BATEMAN	Road Foreman-Assistant Trainmaster	Pocatello, Idaho
H. S. ROSE	Road Foreman-Assistant Trainmaster	Pocatello, Idaho
T. W. GOUGH	Road Foreman-Assistant Trainmaster	Pocatello, Idaho
G. D. MIDDLETON	Road Foreman-Assistant Trainmaster	Pocatello, Idaho
D. L. WRIGHT	Terminal Trainmaster	Nampa, Idaho
M. W. WALL	Road Foreman-Assistant Trainmaster	Nampa, Idaho
L. A. HOFFER	Road Foreman-Assistant Trainmaster	Nampa, Idaho
G. F. HITE	Division Engineer	Pocatello, Idaho
G. G. PHILLIPS	General Roadmaster	Pocatello, Idaho
W. F. JESSE	General Roadmaster	Nampa, Idaho
G. P. WOOD	Manager of Safety	Pocatello, Idaho
I. G. PERKINS	Division Chief Train Dispatcher	Pocatello, Idaho
H. W. BAKER	Manager-Operating Rules	Pocatello, Idaho

### Assistant Chief Dispatchers

T. J. CARNEY	Pocatello, Idaho
A. E. O'BRIEN	Pocatello, Idaho
H. E. GREEN	Pocatello, Idaho
J. R. DRAPER	Pocatello, Idaho
M. M. CAVERHILL	Pocatello, Idaho
W. D. HILL	Pocatello, Idaho
W. ALLEY	Pocatello, Idaho
J. S. RIGBY	Pocatello, Idaho
W. D. BURGEL	Pocatello, Idaho

## OREGON DIVISION

<b>R.J. LARKIN</b>	<b>Superintendent</b>	<b>Albina, Oregon</b>
J. L. VERHAAL	Assistant Superintendent	Albina, Oregon
M. O. DODGE	Superintendent Northern Terminals	Argo, Washington
S. R. COLOSSO	Terminal Superintendent	Argo, Washington
B. E. STANGER	Assistant Terminal Superintendent	Argo, Washington
K. W. PRIDACHUK	Terminal Trainmaster	Argo, Washington
J. M. FREEMAN	Terminal Superintendent	Tacoma, Wash.
R. D. ARNEY	Terminal Superintendent	Albina, Oregon
C. F. PARSONS	Assistant Terminal Superintendent	Albina, Oregon
B. V. LAUGHLIN	Trainmaster	Albina, Oregon
R. MOORE	Trainmaster	Albina, Oregon
C. L. TAYLOR	Terminal Trainmaster	Albina, Oregon
S. E. BURNS	Terminal Trainmaster	Albina, Oregon
K. M. KUBIK	Terminal Trainmaster	Albina, Oregon
J. L. TURNER	Terminal Trainmaster	Albina, Oregon
D. L. JONES	Terminal Trainmaster	Albina, Oregon
V. J. HOES	Terminal Trainmaster	Tacoma, Wash.
H. P. LEWIS	Trainmaster	Spokane, Wash.
K. E. DURANT	Trainmaster	Spokane, Wash.
T. E. SIMON	Terminal Superintendent	Spokane, Wash.
L. R. MARSHALL	Assistant Terminal Superintendent	Hinkle, Oregon
D. C. DODGE	Terminal Trainmaster	Hinkle, Oregon
L. J. FROST	Terminal Trainmaster	Hinkle, Oregon
D. J. DUFFY	Trainmaster	Hinkle, Oregon
D. D. CLIFFORD	Terminal Trainmaster	Hinkle, Oregon
P. N. MARTIN	Trainmaster	The Dalles, Oregon
M. L. GRIFFIN	Trainmaster	La Grande, Oregon
L. D. DAHLIN	Road Foreman-Assistant Trainmaster	La Grande, Oregon
W. T. WATSON	Road Foreman-Assistant Trainmaster	Albina, Oregon
C. D. RHODIG	Road Foreman-Assistant Trainmaster	Albina, Oregon
S. BROOKS	Road Foreman-Assistant Trainmaster	Hinkle, Oregon
R. L. WARNER	Asst. Mechanical Superintendent-West	Albina, Oregon
D. L. MONSON	Division Engineer	Albina, Oregon
G. D. ALTENBURG	General Roadmaster	Albina, Oregon
T. R. KING	General Roadmaster	Spokane, Wash.

J. L. SLANE	Manager of Safety	Albina, Oregon
L. L. McCORMICK	Chief Train Dispatcher	Albina, Oregon
M. S. BARKDULL	Manager-Operating Rules	Spokane, Wash.

### Assistant Chief Dispatchers

G. M. NONNE	Albina, Oregon
C. L. VOEGELE	Albina, Oregon
E. J. BOEHM	Albina, Oregon
R. G. SPJUT	Albina, Oregon
O. G. ADAMS	Albina, Oregon
D. L. LEE	Albina, Oregon
S. E. CROWN	Albina, Oregon
M. B. BURNETT	Albina, Oregon

Union Pacific Operating Rules govern on the following:  
Idaho Division

Oregon Division — First, Second, Third, Fourth and Sixth Subdivisions.

Consolidated Code of Operating Rules govern on the following:

Oregon Division — Fifth Subdivision.

Olympia and Grays Harbor Branches.

### Standard clocks are located as shown below: NORTHWESTERN DISTRICT

Blackfoot	Telegraph Office
Boise Freight	Yard Office
Burns	Telegraph Office
Dillon	Telegraph Office
Emmett	Telegraph Office
Glenns Ferry	Telegraph Office
Huntington	Telegraph Office
Idaho Falls	Telegraph Office
Idaho Falls	Switchmen's Reg. Room
Kemmerer	Telegraph Office
Montpelier	Telegraph Office
Nampa	Switchmen's Locker Room
Nampa	Crew Dispatcher's Office
Nyssa	Telegraph Office
Ontario	Telegraph Office
Pocatello	Train Dispatcher's Office
Pocatello	Crew Dispatcher's Office
Pocatello	Switchmen's Locker Room, New Yd.
Pocatello	Switchmen's Locker Room, Hump
Pocatello	Communications Office
Pocatello	Switchmen's Locker Room, Day St.
Rupert	Telegraph Office
Soda Springs	Telegraph Office
Twin Falls	Telegraph Office

Albina	Train Dispatcher's Office
Albina	Trainmen's Register Room
Albina	Barnes Yard Office
Argo	Trainmen's Register Room
Bend (Joint)	B.N. Inc. Telegraph Office
Bonnors Ferry	Telegraph Office
Centralia (Joint)	B.N. Inc. Tel. Office
Eastport	Telegraph Office
Hinkle	Enginemen's Register Room
Hinkle	Yard Office
Hoquiam (Joint)	B.N. Inc. Tel. Office
Kellogg-Wardner	Telegraph Office
Kellogg-Wardner	Register Room
Kennewick	Telegraph Office
La Grande	Crew Dispatcher's Office
La Grande	Telegraph Office
Moscow	Telegraph Office
Olympia	Telegraph Office
Pendleton	Telegraph Office
Spokane	Telegraph Office
Spokane	Trainmen's Reg. Room
Sandpoint	Telegraph Office
Tacoma	Yard Office
Trentwood	Telegraph Office
The Dalles	Telegraph Office
Troutdale	Telegraph Office
Walla Walla	Telegraph Office
Wallula	Telegraph Office
Yakima	Telegraph Office
Yakima	Trainmen's Register Room

### CONSOLIDATED CODE SYMBOLS AND ABBREVIATIONS

6 (A). The following letters placed in the columns provided in the timetable indicate:

A— automatic interlocking;	P— dispatchers telephone;
B— bulletins — general orders;	Q— radio installation;
C— continuous office;	R— train register;
F— fuel;	T— turntable or wye;
I— manual interlocking;	U— railroad crossing not protected by signals or gates;
J— junction;	W— water;
K— standard clock;	X— crossover;
M— railroad crossing protected by signals or gates;	Y— yard limits;
O— agent or operator;	Z— track scales.

#### Idaho Division Mileage

#### Oregon Division Mileage

Main Track .....	800.7	Main Track .....	764.2
Branches .....	1125.9	Branches .....	946.0
Total .....	1926.6	Total .....	1710.2



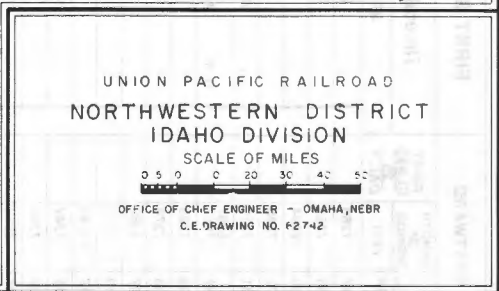
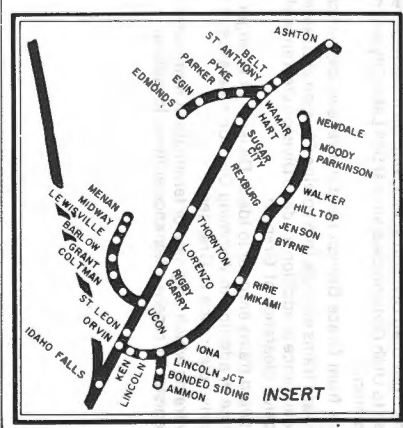
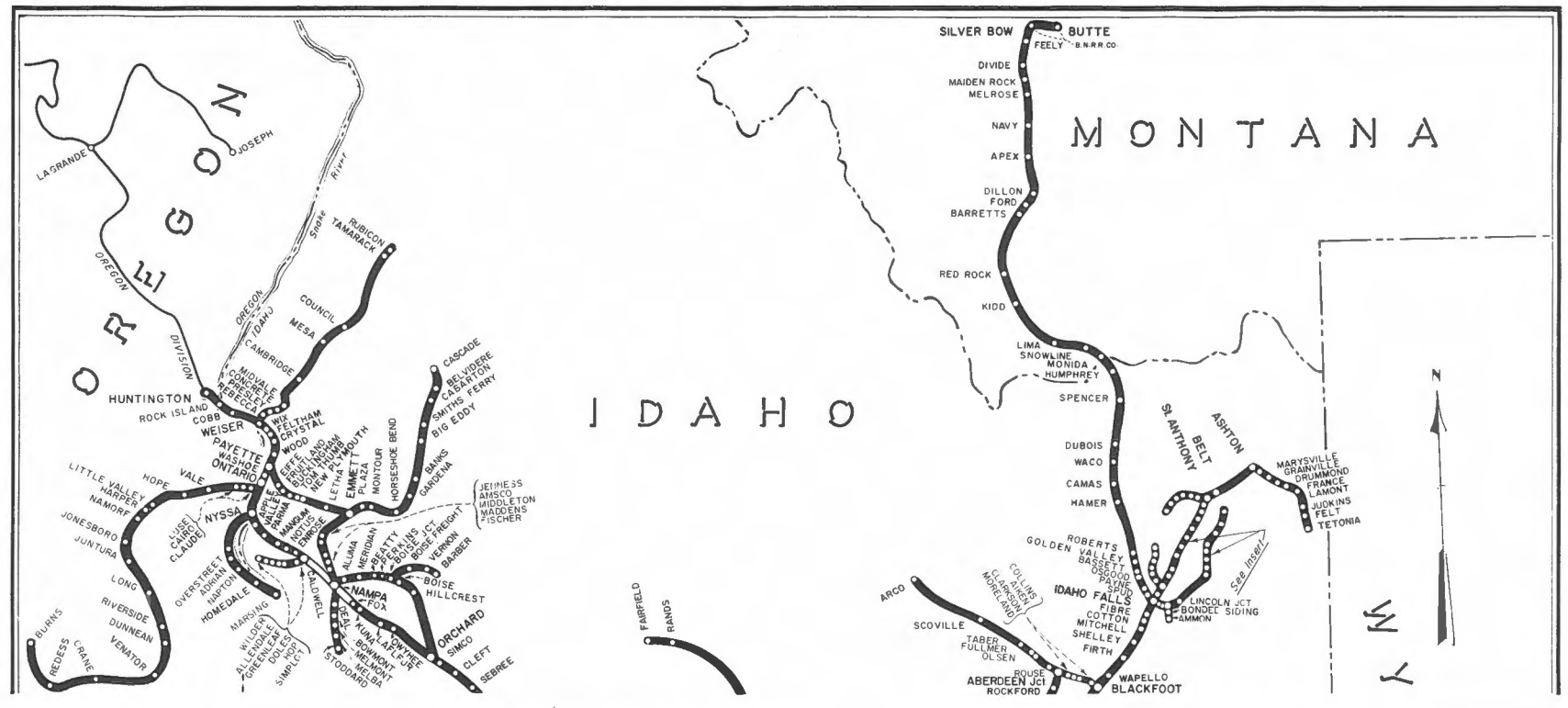

IDAHO DIVISION

WESTWARD			FIRST SUBDIVISION	EASTWARD		
STATION NUMBER	LENGTH OF SIDINGS FEET	FIRST CLASS 26 DAILY	Timetable No. 7	MILE POST	FIRST CLASS 26 DAILY	RULE (B)
			STATIONS			
847	7260		GRANGER	0.0		PY
855	7359		MOXA	8.4		P
863	12034		NUTRIA	16.4		P
872	7345		OPAL	24.7		P
881	7370		WATERFALL	33.3		P
887	6567 7867		D-R KEMMERER	39.9		P
898	7329		FOSSIL	48.0		P
903	7374		NUGGET	53.3		P
907	7352		ORR	59.4		P
910	4712		SAGE	63.0		P
912	11783		LEEFE	65.3		PY
919	7342		BECKWITH	72.0		P
925	7399		PIXLEY	77.4		P
931	8566		COKEVILLE	83.8		P
935	7367		MARSE	88.8		P
941	7331		CHAUSSE	94.5		P
945	2035		PEGRAM	98.1		P
950	7405		HARER	102.3		P
955			DINGLE	107.9		P
962			D-R MONTPELIER	115.0		FPT XY
969			PESCADERO	120.4		P
974	10039		GEORGETOWN	127.7		P
983	7354		MANSON	138.2		P
993	7465		D-R SODA SPRINGS	146.2		PY
999	7297		ALEXANDER	151.2		P
1003	7426		TALMAGE	156.7		P
1009	7112 9050		BANCROFT	162.0		P
1018	7337		PEBBLE	170.3		P
1025			BLASER	177.0		P
1027	1600		LAVA HOT SPRINGS	180.5		PX
1032			TOPAZ	186.0		P
1038		1.57AM	D McCAMMON	191.3	A3.12AM	PXY
1049	5777		INKOM	201.7		PX
1061		A2.20AM	DN-R POCATELLO YL	214.2	2.50AM	FPT XY
			(214.2)			

Note 2 to Rule 99 is in effect on First Subdivision.

**CLEARANCE AND REGISTER REQUIREMENTS**

Trains enroute to Utah Division at McCammon must receive Utah Division clearance, in addition to Idaho Division clearance at Pocatello, and must identify opposing trains between Pocatello and McCammon and need not receive clearance at McCammon.

Trains from Utah Division at McCammon must receive Idaho Division clearance in addition to Utah Division clearance at Salt Lake City and need not receive clearance at McCammon.

Trains from Grace Branch need not receive clearance at Alexander.

Eastward trains enroute to Wyoming Division at Granger must receive Wyoming Division clearance in addition to Idaho Division clearance at their initial station and need not receive clearance at Granger.

Westward trains enroute to Idaho Division at Granger must receive Idaho Division clearance in addition to Wyoming Division clearance at their initial station and need not receive clearance at Granger.

Only trains which originate or terminate at Kemmerer, Montpelier or Soda Springs need register or receive clearance at these locations.

IDAHO DIVISION

SPEED RESTRICTIONS — FIRST SUBDIVISION

LOCATION	MPH		LOCATION	MPH	
	PSGR	FRT		PSGR	FRT
Maximum Speed	70	70	131.6 and 132.2	70	60
Between Mile Posts —			135.6 and 135.8	70	60
Granger Siding	40	40	Manson		
0.0 and 0.8	40	40	138.7 and 139.3	60	50
Opal			141.0 and 141.9	55	45
When switching east end			142.4 and 143.4	65	55
El Paso tracks		5	Soda Springs		
28.7 and 29.6	70	60	143.7 and 146.3	45	45
31.3 and 32.3	50	40	148.0 and 148.3	70	60
33.0 and 33.1	70	60	Alexander		
Waterfall			152.1 and 152.4	60	50
34.6 and 34.8	60	50	Bancroft		
35.5 and 40.8	40	35	163.5 and 164.7	70	60
Kemmerer			167.5 and 168.1	70	60
42.3 and 44.6	65	55	168.9 and 169.3	60	50
Nuggett			Pebble		
54.5 and 55.8	40	30	171.2 and 171.7	60	50
55.9 and 57.8	40	35	171.9 and 174.7	65	55
58.0 and 61.2	70	60	176.3 and 176.7	70	60
63.6 and 65.4	60	50	Blaser		
66.5 and 68.2	65	55	177.4 and 178.5	55	45
Cokeville			179.0 and 180.0	45	35
87.4 and 87.7	60	50	Lava Hot Springs		
92.9 and 93.1	60	50	180.0 and 181.7	65	55
Chausse			181.8 and 183.1	55	45
96.7 and 96.9	70	60	183.2 and 184.8	65	55
98.3 and 99.2	60	50	185.5 and 187.9	35	35
99.5 and 99.7	65	55	188.2 and 190.2	60	50
102.6 and 104.8	60	50	McCammom		
105.2 and 105.4	70	60	192.1 and 192.7	60	50
Pescadero			195.0 and 195.3	60	50
120.6 and 123.4	60	50	197.7 and 200.0	65	55
125.2 and 126.7	60	50	200.0 and 201.0	60	50
Georgetown			Inkom		
127.6 and 130.1	60	50	202.3 and 202.6	60	50

IDAHO DIVISION

# IDAHO DIVISION

WESTWARD			SECOND SUBDIVISION	EASTWARD						
STATION NUMBER	LENGTH OF SIDINGS FEET	FIRST CLASS 25 DAILY	Timetable No. 7			MILE POST	FIRST CLASS 25 DAILY	RULE (B)		
			STATIONS							
1061		2.30AM	ABS	DN-R	POCATELLO	YL	214.2	A2.40AM	FPT XY	
						POCATELLO JCT.	YL	216.3		PX
1067						DON		220.0		PX
1071	C7645					MICHAUD		224.4		P
1074	2869					SCHILLER (SPUR-W)		226.5		P
1077	8267					BANNOCK		230.1		P
1086	7104				D	AMERICAN FALLS		238.7		P
1090	6053					BORAH		242.3		P
1097	8258					QUIGLEY		250.0		P
1103	5952					WAPI		256.0		P
1107	8280				DEWOFF		260.3		P	
1115	5980				HAWLEY		267.4		P	
1120	13190		CTC	D	MINIDOKA		272.6		PY	
1123	5848					MAX		276.8		P
1132	8273					ADELAIDE		284.6		P
1136	5985					KIMAMA		289.8		P
1143	5976					SENER		295.5		P
1151	8359					OWINZA		303.1		P
1161	900					DIETRICH		314.7		P
1169	12870	s4.10AM			D	SHOSHONE		321.8	s1.00AM	PXY
1178	8269					TUNUPA		330.5		P
1185	3150 8232					GOODING		337.7		P
1191	8283				FULLER		344.8		P	
1198	5861				BLISS		350.0		PY	
1205	6021				TICESKA		356.0		P	
1214					KING HILL		367.7		PX	
1221		A5.00AM		D-R	GLENN'S FERRY		374.0	11.59PM	PX	
					(159.8)					

Note 2 to Rule 99 is in effect on Second Subdivision.

### CLEARANCE AND REGISTER REQUIREMENTS

Only trains which originate or terminate at Glenns Ferry need register or receive clearance at Glenns Ferry.

### SPEED RESTRICTIONS — IDAHO SECOND SUBDIVISION

LOCATION	MPH PSGR FRT	LOCATION	MPH PSGR FRT
Maximum Speed Between Pocatello and Glenns Ferry	70 70	323.3 and 323.9	70 60
Westward trains on No. 2 track using cross-over at Pocatello Jct.	15 15	325.0 and 326.6	70 60
Between Mile Posts — 218.8 and 220.0	65 50	Gooding Over public crossings MP 337.5 and 338.0	45 45
American Falls 237.9 and 241.3	65 55	340.7 and 341.2	60 50
Dietrich 314.7 and 316.3 No. 2 Track	55 45	342.3 and 343.4	60 50
Shoshone Over public crossings MP 321.5 and 321.8	35 35	Ticeska 360.2 and 360.8	55 45
Through No. 20 equi- lateral at end of two main tracks, MP 323.1	60 60	364.9 and 366.0	60 60
		King Hill 367.5 and 368.3	70 60
		369.1 and 371.1	60 50
		371.1 and 373.2	45 35
		Glenns Ferry Over Commercial Street crossings MP 374.1	20 20

IDAHO DIVISION

WESTWARD			THIRD SUBDIVISION	EASTWARD			
STATION NUMBER	LENGTH OF SIDINGS FEET	FIRST CLASS 25 DAILY	Timetable No. 7		MILE POST	FIRST CLASS 26 DAILY	RULE 6(B)
			STATIONS				
1221		5.00AM	D-R	GLENN'S FERRY	374.0	A11.59PM	PX
1230	C8399			HAMMETT	382.7		P
1240	C8341			REVERSE	393.3		P
1249	8234		D	MOUNTAIN HOME	401.8		PY
1255	8251			SEBREE	408.2		P
1260	8242			CLEFT	413.7		P
1266	895			SIMCO (SPUR-W)	419.1		P
1270	9349	5.45		ORCHARD	423.6	11.15AM	P
1282	1020			OWYHEE	435.2		P
1286	1020	Operates via Boise Cut-off		LA FLEUER (SPUR-W)	438.9	Operates via Boise Cut-off	P
1294	8053			KUNA	446.4		P
1297				FOX	448.8		P
1304		s7.00	DN-R	NAMPA	456.8	s9.55	FPT XY
1313			D	CALDWELL	465.7		P
1316	6014			ENROSE	469.2		P
1320	8292			NOTUS	472.6		P
1324	1155			MANGUM	476.4		P
1328	8261		D	PARMA	480.4		P
1333	1210			APPLE VALLEY	486.1		P
1336	8717		DN	NYSSA	488.5		PY
1346	8311 8440	s7.40	D	ONTARIO	498.9	s9.15	PY
1348	1485			WASHOE (SPUR-W)	501.1		P
1350	8100		D	PAYETTE	502.7		P
1353	495			WOOD (SPUR-W)	506.4		P
1357	8256			CRYSTAL	509.6		P
1360	1100			FELTHAM	512.9		P
1362	660			WX	514.2		P
1363	8070 8246		D	WEISER	516.1		PY
1373	7974			COBB	526.1		P
1381	8242			ROCK ISLAND	532.8		P
1386	8295	A8.20AM	D-R	HUNTINGTON	538.8	8.30PM	P
				(164.8)			

Note 2 to Rule 99 is in effect on Third Subdivision.

Clearance and Register Requirements — See Next Page.

IDAHO DIVISION

THIRD SUBDIVISION CLEARANCE AND REGISTER REQUIREMENTS

All trains must receive clearance at Nampa.

Only trains which originate or terminate at Glenns Ferry or Huntington need register or receive clearance at Glenns Ferry or Huntington.

Trains enroute to Oregon Division at Huntington must receive Oregon Division clearance in addition to Idaho Division clearance at Nampa and need not receive clearance at Huntington.

Trains No. 25 and 26 may register at Nampa by Train Register Ticket.

SPEED RESTRICTIONS — IDAHO THIRD SUBDIVISION

LOCATION	MPH		LOCATION	MPH	
	PSGR	FRT		PSGR	FRT
Maximum speed	70	70	Nyssa		
Glenns Ferry			Over public crossing		
Over Commercial Street			489.1	60	60
crossing MP 374.1	20	20	Ontario		
Between Mile Posts —			Public crossings		
376.5 and 377.6	60	50	498.7 and 498.8	55	55
Hammett			Tokyo 1 and 2. East		
384.9 and 390.7	60	50	team and East Ware-		
Mountain Home			house Tracks over		
Over public crossings			5th and 6th Avenue		
400.75 and 402.25	35	35	crossing.	5	5
Kuna			Payette		
447.3 and 450.8	70	60	Public crossings		
454.7 and 456.0			502.6 and 503.2	60	60
No. 1 track	65	55	Crystal		
No. 2 track	40	40	When using turn out		
Fox			East end.	15	15
448.8 and 454.7			Weiser		
No. 2 track	50	50	515.8 and 516.4	60	60
Nampa			523.2 and 524.9	70	60
456.0 and 457.1			524.9 and 528.1	60	50
No. 1 track	35	35	529.4 and 535.5	70	60
456.0 and 458.0			535.5 and 536.9	55	45
No. 2 track	20	20	536.9 and 539.0	40	30
458.0 and 464.8			Huntington		
No. 2 track	50	50	Between Oregon		
Caldwell			Division Mile Posts —		
465.0 and 466.0	50	50	389.9 and 388.5	45	40
Parma			Huntington — Thru siding	15	15
Public crossings					
481.0 and 481.3	60	60			

IDAHO DIVISION

IDAHO DIVISION

IDAHO DIVISION

WESTWARD			FOURTH SUBDIVISION	EASTWARD		
STATION NUMBER	LENGTH OF SIDINGS FEET	SECOND CLASS 277 DAILY	Timetable No. 7			
			STATIONS	MILE POST	SECOND CLASS 278 DAILY	RULE 8(B)
1061			POCATELLO JCT. YL	135.1		P
		11.01AM	MONTANA JCT. YL	136.7	A8.10AM	P
99-138	1265		CHUBBUCK (SPUR E-W)	138.2		
99-140	5885	11.06	TYHEE	140.8	8.02	
99-146	7095	11.13	FORT HALL	146.0	7.55	P
99-151	3410	11.20	GIBSON	151.0	7.48	
99-158	3685	11.30	DN BLACKFOOT YL	158.1	7.38	PY
99-164	3465	11.40	WAPELLO	164.0	7.28	
99-169	5830	11.47	D FIRTH	169.4	7.21	P
99-176	4950	11.56AM	D SHELLY	175.5	7.12	P
99-177	825		MITCHELL	176.9		
99-179	3410	12.10PM	COTTON	179.3	7.07	
99-180	385		FIBRE (SPUR-E)	180.4		
99-185		12.27	DN-R IDAHO FALLS YL	184.8	7.01	FP TY
99-190	715		SPUD (SPUR-E)	189.6		
99-191	2475	12.36	PAYNE	191.2	6.26	
99-195			OSGOOD (SPUR-W)	195.0		
99-197	2585	12.43	BASSETT	196.5	6.19	
99-199	1320		GOLDEN VALLEY (SPUR-E) (SPUR-W)	198.2		
99-202	2585	12.50	ROBERTS	202.0	6.12	
99-218	2475	1.07	HAMER	217.5	5.55	
99-223	2420	1.15	CAMAS	223.3	5.47	
99-229	1650		WACO	228.6		
99-235	5060	1.28	DUBOIS	234.9	5.34	Y
99-249	2750	1.48	SPENCER	248.5	5.12	
99-258	5595	2.07	HUMPHREY	258.5	4.53	
99-265	2915	2.20	MONIDA	264.7	4.40	Y
99-273	2420	2.35	SNOWLINE	273.3	4.25	P
99-280	4455	2.45	LIMA	280.5	4.15	
99-294	2310	3.07	KIDD	294.0	3.51	
99-303	7370	3.17	RED ROCK	301.8	3.41	
99-320	7590	3.43	BARRETTS	320.2	3.15	
99-322	1265		FORD	322.2		
99-328	7095	4.05	DN-R DILLON YL	328.0	3.01	P
99-340	2145	4.22	APEX	340.3	2.15	
99-349	2255	4.43	NAVY	348.5	1.54	Y
99-359	2915	5.01	MELROSE	358.8	1.37	
99-366	1100		MAIDEN ROCK	365.8		
99-370	1870	5.27	DIVIDE	369.9	1.10	
99-381	880	5.47	FEELY	380.6	12.50	
99-390	3010	A6.10PM	DN-R SILVER BOW YL	390.0	12.30AM	PY
99-397		A7.01PM	D BUTTE YL	397.0	12.01AM	P
			(261.9)			

Westward trains are superior to trains of the same class in the opposite direction. — See Rule 72.

Note 2 to Rule 99 is in effect between Pocatello Jct. and Idaho Falls and between Spencer and Humphrey.

Time shown at Butte is for information only. Between Silver Bow and Butte, trains are governed by operating rules, timetable and special instructions of Burlington Northern, Inc.

CLEARANCE REQUIREMENTS

All trains must receive clearance at: Idaho Falls, Dillon.

Westward trains must receive clearance at Pocatello and need not receive clearance at Pocatello Jct. or Montana Jct.

IDAHO DIVISION

SPEED RESTRICTIONS — FOURTH SUBDIVISION

LOCATION	MPH	LOCATION	MPH
Maximum speed		Spencer	
Between Pocatello Jct. and Idaho Falls	60	247.9 and 251.0	45
		251.0 and 251.4	35
Between Idaho Falls and Silver Bow	49	252.7 and 254.9	25
		254.9 and 257.6	20
Between Mile Posts — Pocatello Jct. 135.1 and 136.7	25	Humphrey	
		258.3 and 259.2	30
Tyhee		262.9 and 267.6	30
142.3 and 143.5	50		
152.6 and 152.9	50	Monida	
		269.7 and 269.9	35
Blackfoot		271.0 and 271.8	35
Over public crossings			
157.3 and 158.8	20	Snowline	
		277.4 and 279.7	30
Firth		Lima	
Public crossing 169.5	35	Over public crossings	
		279.7 and 280.3	15
Shelley		Red Rock	
Over public crossings		309.2 and 310.2	30
175.0 and 176.0	30		
Idaho Falls		Over public crossings	
Over public crossings		182.5 and 185.5	25
182.5 and 185.5	25		
		185.5 and 185.9	10
		187.4 and 188.6	35
		190.7 and 191.0	40
Roberts			
205.4 and 206.1	45		
208.4 and 210.2	45		
213.7 and 214.0	45		
Hamer			
218.3 and 218.5	45		
Dubois			
235.6 and 236.7	35		
237.8 and 238.0	45		
239.1 and 239.3	45		
244.4 and 246.7	35		

**IDAHO DIVISION — First Subdivision Branches**

WESTWARD		CUMBERLAND BRANCH		EASTWARD	
STATION NUMBER	LENGTH OF SIDINGS	Timetable No. 7		MILE POST	RULE 6(B)
	FEET	STATIONS			
887	7477 7867	DN-R	KEMMERER YL	0.0	P
227-05	2475		GLENCOE JCT. YL	5.3	
			FMC COAL SPUR YL	10.9	
(6.0)					

Cumberland Branch yard limits are continuous from MP 0.0 to end of branch at MP 10.9.

**SPEED RESTRICTIONS — CUMBERLAND BRANCH**

LOCATION	MPH	LOCATION	MPH
Maximum speed	20	FMC Spur	
Between Mile Posts — 0.0 and 0.3	15	Maximum speed	20
4.9 and 5.6	15	10.0 and 10.9	10

WESTWARD		ELKOL BRANCH		EASTWARD	
STATION NUMBER	LENGTH OF SIDINGS	Timetable No. 7		MILE POST	RULE 6(B)
	FEET	STATIONS			
227-05	2475		GLENCOE JCT. YL	0.0	
229-04			ELKOL YL	3.2	
(3.2)					

Elkol Branch yard limits are continuous from MP 0.0 to end of branch at MP 3.2.

**SPEED RESTRICTION — ELKOL BRANCH**

LOCATION	MPH	LOCATION	MPH
Maximum speed	20	1.0 and 2.5 on descending grade	20
Between Mile Posts — 0.0 and 0.2	15	2.5 and end of Track	15

WESTWARD		GRACE BRANCH		EASTWARD	
STATION NUMBER	LENGTH OF SIDINGS	Timetable No. 7		MILE POST	RULE 6(B)
	FEET	STATIONS			
999	7297		ALEXANDER YL	0.0	P
235-06	770		GRACE YL	6.0	
(6.0)					

Grace Branch yard limits are continuous from MP 0.0 to End of Branch.

**SPEED RESTRICTIONS — GRACE BRANCH**

LOCATION	MPH	LOCATION	MPH
Maximum speed	20	Grace Elevator Tracks	5
Truss Bridge MP 5.33	10		

**IDAHO DIVISION — First Subdivision Branches**

WESTWARD		CONDA BRANCH		EASTWARD	
STATION NUMBER	LENGTH OF SIDINGS	Timetable No. 7		MILE POST	RULE 6(B)
	FEET	STATIONS			
993	7465	DN-R	SODA SPRINGS YL	0.0	PY
360-02	3740		MONSANTO YL	1.8	
360-06	825		EPCO YL	6.0	
360-07			CONDA YL	7.0	Y
(7.0)					

Conda Branch yard limits are continuous from MP 0.0 to End of Branch.

**SPEED RESTRICTIONS — CONDA BRANCH**

LOCATION	MPH	LOCATION	MPH
Maximum speed	20	Conda Yard	5

WESTWARD		DRY VALLEY BRANCH		EASTWARD	
STATION NUMBER	LENGTH OF SIDINGS	Timetable No. 7		MILE POST	RULE 6(B)
	FEET	STATIONS			
360-06	9873		EPCO YL	0.0	
370-12			WOOLEY VALLEY	11.7	
370-18			DRY VALLEY	18.4	Y
(18.4)					

**SPEED RESTRICTIONS — DRY VALLEY BRANCH**

LOCATION	MPH	LOCATION	MPH
Maximum speed.	25	Between Mile Posts — 0.0 and 1.0	15
EpcO - all yard tracks	10	3.5 and 4.9	15
Exception: Mountain Fuel Track No. 1	5	17.5 and 18.4	5
Center Load Track above rollover dumper	5		

**TRAIN MOVEMENTS**

Train movements on Dry Valley Branch are authorized by Radio Block clearance. See Special Rule 96(RI).

**IDAHO DIVISION — Second Subdivision Branches**

WESTWARD		TWIN FALLS BRANCH			EASTWARD	
STATION NUMBER	LENGTH OF SIDINGS	Timetable No. 7			MILE POST	RULE 6(B)
	FEET	STATIONS				
1120	13190	D-R	MINIDOKA	YL	0.0	PY
236-08	3410		ACEQUIA		8.1	P
236-14	9185	DN	RUPERT	YL	13.5	PY
236-16	715		SCHOW	YL	16.5	
236-20	1485		HEYBURN	YL	19.6	
236-22	2750 2970	DN	BURLEY	YL	21.8	PY
236-26	3575		STARRH'S FERRY	YL	26.0	
236-28	1265		HOBSON (SPUR-E)		28.5	
236-34	2750		MILNER		33.6	
236-41	3355		MURTAUGH		41.8	
236-48	1100		BILLS		49.0	
236-50	1925		HANSEN		49.7	
236-53	2805		KIMBERLY		53.3	
236-56	1430		McMILLAN	YL	56.4	
236-59		DN-R	TWIN FALLS	YL	59.0	PY
236-63	1980		CURRY		63.4	
236-66	2805		FILER		66.0	P
236-69	2090		PEAVEY		68.5	
236-71	1925		CEDAR		71.4	
236-74		D	BUHL	YL	73.8	PY
			(73.8)			

Maintenance of Way Rule 99(J) does not apply.

**CLEARANCE REQUIREMENTS**

All trains must receive clearance at Twin Falls. Twin Falls Branch Yard Limits are continuous from MP 19.0 to MP 26.75 and MP 55.7 to MP 60.3.

**SPEED RESTRICTIONS — TWIN FALLS BRANCH**

LOCATION	MPH	LOCATION	MPH
Maximum speed	40	Burley, over street crossings	12
Rupert, over streets and alleys	12	Kimberly, within city limits	35

WESTWARD		RAFT RIVER BRANCH			EASTWARD	
STATION NUMBER	LENGTH OF SIDINGS	Timetable No. 7			MILE POST	RULE 6(B)
	FEET	STATIONS				
236-22	2970	DN-R	BURLEY	YL	0.0	PY
239-03	1595		UNITY	YL	3.1	
239-04	1320		ELCOCK	YL	4.0	
239-05	715		EVANS (SPUR-E)	YL	4.7	
239-06	1045		SPRINGDALE	YL	6.0	
239-08	1155		HATCH	YL	7.5	
239-09	770		DECLO	YL	9.0	
			(9.0)			

Raft River Branch yard limits are continuous from MP 0.0 to End of Branch.

**SPEED RESTRICTIONS — RAFT RIVER BRANCH**

LOCATION	MPH	LOCATION	MPH
Maximum speed	20	Burley, over street crossings	12

Westward trains are superior to trains of the same class in the opposite direction. — See Rule 72.

**IDAHO DIVISION — Second Subdivision Branches**

WESTWARD		KETCHUM BRANCH			EASTWARD	
STATION NUMBER	LENGTH OF SIDINGS	Timetable No. 7			MILE POST	RULE 6(B)
	FEET	STATIONS				
1169		D-R	SHOSHONE	YL	0.0	PY
242-15	1815		RICHFIELD		15.1	Y
			(15.65)			

**SPEED RESTRICTIONS — KETCHUM BRANCH**

LOCATION	MPH
Maximum speed	40

WESTWARD		HILL CITY BRANCH			EASTWARD	
STATION NUMBER	LENGTH OF SIDINGS	Timetable No. 7			MILE POST	RULE 6(B)
	FEET	STATIONS				
242-15	1815		RICHFIELD		0.0	Y
243-37	330		RANDS		36.8	
243-44	1980		FAIRFIELD		44.0	
			(44.5)		44.5	

**SPEED RESTRICTIONS — HILL CITY BRANCH**

LOCATION	MPH	LOCATION	MPH
Maximum speed	25	Between Mile Posts — 0.0 and 0.3	15

WESTWARD		OAKLEY BRANCH			EASTWARD	
STATION NUMBER	LENGTH OF SIDINGS	Timetable No. 7			MILE POST	RULE 6(B)
	FEET	STATIONS				
236-22	2750	DN-R	BURLEY	YL	0.0	PY
237-02	320		CRIPPEN (SPUR-E)		2.1	
237-03	110		RUBY (SPUR-W)		3.1	
237-04	1320		BEEVILLE		4.3	
237-05	1100		PELLA		5.2	
237-08	3080		NORTH KENYON		8.1	
237-10	440		KENYON		9.6	
237-12	296		MARTIN (SPUR-E)		11.5	
237-14	495		CHURCHILL		13.5	
237-16	1100		TROUT		16.3	
237-18	385		MARION		17.8	
237-19	1155		WARR		19.0	
237-22	935		OAKLEY		21.8	
			(21.8)			

Movements on Oakley Branch are governed by the Staff System. Staff located in staff box at Burley Depot. See Special Rule 300(R) and 300(R-1).

**SPEED RESTRICTIONS — OAKLEY BRANCH**

LOCATION	MPH	LOCATION	MPH
Maximum speed	25	Burley, over street crossings	12

**IDAHO DIVISION — Second Subdivision Branches**

WESTWARD		NORTH SIDE BRANCH		EASTWARD	
STATION NUMBER	LENGTH OF SIDINGS	Timetable No. 7		MILE POST	RULE 6(B)
	FEET	STATIONS			
236-14	9185	DN-R	RUPERT YL 3.5	0.0	PY
238-04	825		TRAVERS YL 0.9	3.5	
238-05	7865		MYERS YL 1.3	4.4	
238-06	1705		PAUL YL 5.7	5.7	
238-11	825		HYNES 4.5	11.4	
238-16	2530		SCHODDE 8.1	15.9	
238-24	1045		HAZELTON 2.9	24.0	
238-27	1320		BLACK 1.2	26.9	
238-28	970		EDEN 10.2	28.1	
238-38	550		SUGAR LOAF 2.3	38.3	
238-41	1155		FALLS CITY 1.9	40.6	
238-43	495		BARRYMORE 3.3	42.5	
238-46	330		HYDRA 2.1	45.8	
238-48	2530	D	JEROME 8.8	47.9	PY
238-57	2530		WENDELL 1.4	56.7	
238-58	825		KING 8.1	58.1	
238-66	430		TUTTLE 6.7	66.2	
1198	5845		BLISS (72.9)	72.9	PY

Maintenance of Way Rule 99(J) does not apply.

Trains to or from Second Subdivision need not receive clearance at Bliss.  
North Side Branch yard limits are continuous from MP 0.0 to MP 6.3

**SPEED RESTRICTIONS — NORTH SIDE BRANCH**

LOCATION	MPH
Maximum Speed	40

Westward trains are superior to trains of the same class in the opposite direction. — See Rule 72.

**IDAHO DIVISION — Third Subdivision Cut-Off**

WESTWARD		BOISE CUT-OFF		EASTWARD			
STATION NUMBER	LENGTH OF SIDINGS	FIRST CLASS 25 DAILY	Timetable No. 7		MILE POST	FIRST CLASS 26 DAILY	RULE 6(B)
	FEET		STATIONS				
1270	9349	5.45AM	ORCHARD 21.7	B423.5	A11.15PM	P	
8-1292	660	6.15	HILLCREST 3.4	B445.2	10.43	P	
8-1296		6.25	BOISE YL 0.6	B448.6	10.40	PY	
8-1298			BOISE JCT. 3.4	B450.9		P	
8-1299	1430		PERKINS 2.6	B451.5		P	
8-1302	1375		BEATTY 5.3	B454.9		P	
8-1305	3850	6.40	MERIDIAN 5.0	B457.5	10.10	P	
8-1311			ALUMA (SPUR-W)	B462.8			
1304		A7.00AM	DN-R NAMPA YL (44.3)	B467.8	9.55PM	FP TY	

**CLEARANCE REQUIREMENTS**

Trains to or from Third Subdivision need not receive clearance at Orchard.

**SPEED RESTRICTIONS — BOISE CUT-OFF**

LOCATION	MPH	LOCATION	MPH
Boise Cut-off		Boise	
Maximum speed	40	Over public crossings between MP B-446.5 and MP B-451.25	20
Between Mile Posts — Orchard			
B-439.5 and B-440.4	25		

**IDAHO DIVISION — Third Subdivision Branches**

WESTWARD		IDAHO NORTHERN BRANCH		EASTWARD	
STATION NUMBER	LENGTH OF SIDINGS	Timetable No. 7		MILE POST	RULE 6(B)
	FEET	STATIONS			
1304		D-C	DN-R NAMPA YL	0.0	FPY
24-003	2310		2.6 FISCHER YL	2.6	P
24-006	275		3.5 MADDENS	6.1	
24-009	660		3.3 MIDDLETON	9.4	
24-014	550		4.2 AMSCO (SPUR-E)	13.6	
24-019	715		5.2 JENNESS	18.8	
24-027	4510		8.1 D-R EMMETT YL	26.9	PY
24-032	1980		4.9 PLAZA	31.8	
24-041	2035		9.2 MONTOUR	41.0	
24-050	1485		8.7 HORSESHOE BEND YL	49.7	
24-055	1485	5.2 GARDENA	54.9		
24-064	1650	9.0 BANKS	63.9		
24-075		11.3 BIG EDDY (SPUR-E)	75.2		
24-083	1430	7.5 SMITHS FERRY	82.7	PY	
24-093	715	10.0 CABARTON	92.7		
24-096	1485	2.6 BELVIDERE	95.3		
24-099	1485	3.8 D CASCADE YL	99.1	PY	
			(99.7)		

Yard limits are continuous MP 0.0 to MP 3.58.

**CLEARANCE REQUIREMENTS**

All trains must receive clearance at Emmett.

**SPEED RESTRICTIONS — IDAHO NORTHERN BRANCH**

LOCATION	MPH	LOCATION	MPH
Maximum speed	40	37.4 and 38.7	15
Between Mile Posts — 0.2 and 0.4	15	38.7 and 40.3	30
8.7 and 8.8	25	44.1 and 45.7	35
13.8 and 14.8	30	45.7 and 49.1	25
18.9 and 22.4	15	50.3 and 53.0	20
Trains handling high cars between Jenness and MP 22.4	12	53.0 and 60.0	15
Emmett, over street crossings	12	60.0 and 64.0	20
31.2 and 33.2	25	64.0 and 81.0	15
33.2 and 37.4	20	83.1 and 92.5	20
		92.5 and 98.1	30

**IDAHO DIVISION — Third Subdivision Branches**

WESTWARD		PAYETTE BRANCH		EASTWARD	
STATION NUMBER	LENGTH OF SIDINGS	Timetable No. 7		MILE POST	RULE 6(B)
	FEET	STATIONS			
1350	8100	D-R	PAYETTE YL	0.0	P
253-04	325		3.8 EIFFIE (SPUR-W)	3.8	
253-05	1265		1.3 FRUITLAND	5.1	
253-07	880		1.7 BUCKINGHAM	6.8	
253-08			2.0 TOM THUMB	8.8	
253-11	1430		2.3 NEW PLYMOUTH	11.1	
253-22	495		10.5 LETHA	21.6	
24-027	4510	D-R	8.1 EMMETT YL	29.7	PY
			(29.7)		

**SPEED RESTRICTIONS — PAYETTE BRANCH**

LOCATION	MPH	LOCATION	MPH
Maximum speed	40	Public crossing MP 6.9	10
Between Mile Posts — 0.0 and 0.7	10	9.6 and 9.8	25
1.1 and 4.9	25	10.6 and 10.8	25
6.5 and 6.7	25	13.7 and 13.9	35
		25.2 and 25.6	35
		Emmett, over street crossings	12

Westward trains are superior to trains of the same class in the opposite direction. — See Rule 72.

WESTWARD		NEW MEADOWS BRANCH		EASTWARD	
STATION NUMBER	LENGTH OF SIDINGS	Timetable No. 7		MILE POST	RULE 6(B)
	FEET	STATIONS			
1363	8246	D	WEISER YL	0.0	PY
244-06	1650		6.0 REBECCA	6.0	
244-12	440		5.6 PRESLEY	11.6	
244-19	2255		7.5 CONCRETE	19.1	
244-32	1155		12.7 MIDVALE	31.8	
244-41	1650		8.7 CAMBRIDGE	40.5	
244-57	1210		16.1 MESA (SPUR-W)	56.6	
244-60	2750	D	3.5 COUNCIL YL	60.1	Y
244-82	1375		21.7 TAMARACK	81.8	Y
244-84	2035		2.3 RUBICON	84.1	Y
			(84.5)		

**SPEED RESTRICTIONS — NEW MEADOWS BRANCH**

LOCATION	MPH	LOCATION	MPH
Maximum speed	40	36.8 and 39.1	20
Between Mile Posts — 4.3 and 5.7	35	39.1 and 42.4	30
7.4 and 7.7	25	42.4 and 43.2	20
9.9 and 11.0	25	45.1 and 54.8	25
11.0 and 29.3	20	54.8 and 56.7	20
32.9 and 33.5	25	65.4 and 67.3	30
33.5 and 34.3	20	67.3 and 80.7	20
34.3 and 36.8	25	83.9 and end of track	20

Westward trains are superior to trains of the same class in the opposite direction. — See Rule 72.

**IDAHO DIVISION — Third Subdivision Branches**

WESTWARD		OREGON EASTERN BRANCH		EASTWARD	
STATION NUMBER	LENGTH OF SIDINGS	Timetable No. 7		MILE POST	RULE 6(B)
	FEET	STATIONS			
1346	8440	D	ONTARIO YL	0.0	PY
25-003	385		2.7 CLAUDE (SPUR-W) YL	2.7	
25-004	660		1.0 CAIRO YL	3.7	
25-007	1760		3.2 LUSE	6.9	
25-016	6325		8.6 VALE	15.5	
25-024	2145		8.0 HOPE	23.5	
25-035	2420		11.3 LITTLE VALLEY	34.8	
25-042	2475		7.2 HARPER	42.0	
25-051	2365		9.3 NAMORF	51.3	
25-062	1265		10.9 JONESBORO	62.2	
25-074	2475		11.4 JUNTURA	73.6	Y
25-087	2365		13.0 LONG	86.6	
25-093	2310		6.2 RIVERSIDE	92.8	
25-103	1430		10.0 DUNNEAN	102.8	
25-110	1375		7.4 VENATOR	110.2	
25-127	1430		16.4 CRANE	126.6	
25-144	1430		16.9 REDESS	143.5	
25-157	1155		13.3 BURNS YL	156.8	Y
			(156.8)		

Oregon Eastern Branch yard limits are continuous MP 0.0 to MP 4.0.

**SPEED RESTRICTIONS — OREGON EASTERN BRANCH**

LOCATION	MPH	LOCATION	MPH
Maximum speed	40	66.9 and 68.4	30
Between Mile Posts — 4.0 and 27.8	20	70.3 and 71.2	20
27.8 and 28.6	25	71.2 and 72.2	30
29.5 and 33.8	20	74.9 and 77.0	30
36.8 and 38.1	20	78.6 and 89.3	25
47.5 and 48.2	35	89.3 and 91.1	35
48.2 and 50.8	30	95.1 and 97.4	30
50.8 and 52.2	25	102.0 and 157.2	20
53.7 and 59.3	25		
59.3 and 61.4	30		
63.9 and 65.1	30		

WESTWARD		STODDARD BRANCH		EASTWARD	
STATION NUMBER	LENGTH OF SIDINGS	Timetable No. 7		MILE POST	RULE 6(B)
	FEET	STATIONS			
1304		DN-R	NAMPA YL	0.0	FPTY
246-04	825		4.5 DEAL YL	4.5	
246-09	2090		4.4 BOWMONT YL	8.9	
246-12	330		2.7 MELMONT (SPUR-E) YL	11.6	
246-15	1320		3.0 MELBA YL	14.6	
146-17	2530		2.4 STODDARD YL	17.0	
			(17.0)		

Stoddard Branch yard limits are continuous from MP 0.0 to End of Branch.

**IDAHO DIVISION — Third Subdivision Branches**

**SPEED RESTRICTIONS — STODDARD BRANCH**

LOCATION	MPH	LOCATION	MPH
Maximum speed	20	Between Stoddard and end of track	15
Between Mile Posts 0.0 and 0.8	15		
1.0 and 15	10		

Westward trains are superior to trains of the same class in the opposite direction. — See Rule 72.

WESTWARD		HOMEDALE BRANCH		EASTWARD	
STATION NUMBER	LENGTH OF SIDINGS	Timetable No. 7		MILE POST	RULE 6(B)
	FEET	STATIONS			
1336	8717	DN-R	NYSSA YL	0.0	PY
248-08	1870		8.1 OVERSTREET	8.1	
248-11	935		2.5 ADRIAN	10.6	
248-17	1485		6.3 NAPTON	16.9	
248-24	2915		7.6 HOMEDALE	24.5	
248-33	880		8.6 MARSING	33.1	
			(33.1)		

**SPEED RESTRICTION — HOMEDALE BRANCH**

LOCATION	MPH
Maximum Speed	25

WESTWARD		WILDER BRANCH		EASTWARD	
STATION NUMBER	LENGTH OF SIDINGS	Timetable No. 7		MILE POST	RULE 6(B)
	FEET	STATIONS			
1313		D-R	CALDWELL YL	0.0	P
247-03	1870		2.5 SIMPLOT YL	2.5	
247-04	990		1.2 WEITZ YL	3.7	
247-04	605		0.7 HOP (SPUR-E) YL	4.4	
247-05	1210		0.6 DOLES YL	5.0	
247-07	440		2.0 GREENLEAF (SPUR-W) YL	7.0	
247-10	605		2.7 ALLENDALE YL	9.7	
247-12	2035		1.3 WILDER YL	11.0	
			(11.0)		

Wilder Branch yard limits are continuous from MP 0.0 to End of Branch.

**SPEED RESTRICTIONS — WILDER BRANCH**

LOCATION	MPH	LOCATION	MPH
Maximum speed	20	Between MP 0.0 and 0.3	10

WESTWARD		BOISE BRANCH		EASTWARD	
STATION NUMBER	LENGTH OF SIDINGS	Timetable No. 7		MILE POST	RULE 6(B)
	FEET	STATIONS			
8-1298			BOISE JCT. YL	0.0	
245-03		D	3.2 BOISE FREIGHT YL	3.2	P
245-06	495		3.1 VERNON (SPUR-E,W) YL	6.3	
245-08			2.1 BARBER YL	8.4	
			(8.4)		

Boise Branch yard limits are continuous from MP 0.0 to End of Branch.

IDAHO DIVISION

IDAHO DIVISION

**SPEED RESTRICTIONS — BOISE BRANCH**

LOCATION	MPH
Maximum speed	10
Over public crossings MP 2.6 to MP 3.6	5

Westward trains are superior to trains of the same class in the opposite direction. — See Rule 72.

**IDAHO DIVISION — Fourth Subdivision Branches**

WESTWARD		GAY BRANCH	EASTWARD	
STATION NUMBER	LENGTH OF SIDINGS	Timetable No. 7 STATIONS	MILE POST	RULE 6(B)
	FEET			
99-146	7095	FORT HALL	0.0	P
	1650	NINE MILE	9.3	
380-20		GAY	20.4	Y
		(20.4)		

Movements on Gay Branch are governed by Staff System. Staff located in phone booth at Fort Hall at the switch from Fort Hall siding to Gay Branch. See Special Rule 300(R) and 300(R-1).

**SPEED RESTRICTIONS — GAY BRANCH**

LOCATION	MPH
Maximum Speed	20
Between Mile Posts — 0.0 and 0.2	15
3.1 and Gay	15

WESTWARD		GOSHEN BRANCH	EASTWARD	
STATION NUMBER	LENGTH OF SIDINGS	Timetable No. 7 STATIONS	MILE POST	RULE 6(B)
	FEET			
255-18	1430	AMMON	18.1	
255-21		BONDED SIDING (SPUR-W)	20.8	
264-03		LINCOLN JCT.	21.6	
		(3.5)		

MP 0.06 to MP 17.53 — side track

**SPEED RESTRICTIONS — GOSHEN BRANCH**

LOCATION	MPH	LOCATION	MPH
Maximum speed	25	21.4 and 21.6	10

WESTWARD		ABERDEEN BRANCH	EASTWARD	
STATION NUMBER	LENGTH OF SIDINGS	Timetable No. 7 STATIONS	MILE POST	RULE 6(B)
	FEET			
256-07		ABERDEEN JCT.	0.0	
259-04	1485	ROCKFORD	4.1	
259-06	880	LIBERTY	5.9	
259-10	1485	PINGREE	10.3	
259-17	1430	SPRINGFIELD	16.5	
259-28	1760	D ABERDEEN	28.2	Y
		(28.2)		

Movements on Aberdeen Branch are governed by Staff System. Staff located in phone booth at Aberdeen Jct. See Special Rule 300(R) and 300(R-1).

**IDAHO DIVISION — Fourth Subdivision Branches**

**SPEED RESTRICTIONS — ABERDEEN BRANCH**

LOCATION	MPH	LOCATION	MPH
Maximum speed	25	Cars exceeding gross weight of 240,000 pounds but not exceeding 263,000 lbs.	15

Westward trains are superior to trains of the same class in the opposite direction. — See Rule 72.

WESTWARD			YELLOWSTONE BRANCH	EASTWARD		
STATION NUMBER	LENGTH OF SIDINGS	SECOND CLASS	Timetable No. 7 STATIONS	MILE POST	SECOND CLASS	RULE 6(B)
	FEET	477 Daily Except Saturday and Sunday			478 Daily Except Saturday and Sunday	
99-185		6.00AM	DN-R IDAHO FALLS YL	0.0	A4.40PM	FP TY
26-003	825	6.10	ORVIN YL	3.0	4.25	P
26-004			ST. LEON (SPUR-E)	3.7		
26-008	2805	6.23	UCON	7.6	4.15	P
26-013			GARRY (SPUR-E)	12.5		
26-014	2530	6.42	RIGBY	13.8	4.00	
26-018	1705	6.50	LORENZO	18.1	3.45	P
26-021	1155	6.57	THORNTON	20.7	3.35	
26-026	3135	7.10	D REXBURG	26.0	3.20	P
26-030	2420	7.20	D SUGAR CITY	29.8	3.10	
26-031	1705		HART	30.7		Y
26-032			WAMAR (SPUR-E)	31.3		
26-037	5225	7.35	D ST. ANTHONY YL	36.8	2.55	PY
26-038			BELT YL	38.3		
26-051	2145	A8.10AM	D-R ASHTON YL	51.0	2.20PM	PY
			(51.0)			

Maintenance of Way Rule 99(J) does not apply.

Yellowstone Branch yard limits are continuous from MP 0.0 to MP 3.0 and from MP 34.7 to MP 38.4.

**SPEED RESTRICTIONS — YELLOWSTONE BRANCH**

LOCATION	MPH	LOCATION	MPH
Maximum speed	40	St. Anthony, over highway crossing just west of depot	10
Rexburg, Sugar City and St. Anthony, over streets	20		

Westward trains are superior to trains of the same class in the opposite direction. — See Rule 72.

**IDAHO DIVISION — Fourth Subdivision Branches**

WESTWARD		EAST BELT BRANCH		EASTWARD	
STATION NUMBER	LENGTH OF SIDINGS	Timetable No. 7		MILE POST	RULE 6(B)
	FEET	STATIONS			
26-003	825	ORVIN YL		0.0	PY
264-00		KEN (SPUR-W) YL		0.4	
264-02	1045	LINCOLN YL		2.2	
264-03		LINCOLN JCT. YL		3.0	
264-06	2145	IONA		5.3	
264-14	330	MIKAMI (SPUR-E)		14.0	
264-16	990	RIRIE		16.2	
264-21	495	BYRNE		21.2	
264-26	495	JENSON		25.5	
264-28	670	HILLTOP (SPUR-E)		27.3	
264-28	1100	WALKER		28.1	
264-32	1870	PARKINSON		32.2	
264-34	495	MOODY		34.3	
264-38	550	D	NEWDALE	38.0	P
			(38.0)		

East Belt Branch yard limits are continuous from MP 0.0 to MP 3.2.

**SPEED RESTRICTIONS — EAST BELT BRANCH**

LOCATION	MPH	LOCATION	MPH
Maximum speed	40	19.5 and 24.0	20
Between Mile Posts — 4.7 and 4.9	20	28.0 and 28.7	35
16.0 and 16.3	20	30.2 and 37.7	25
18.8 and 19.0	25		

WESTWARD		WEST BELT BRANCH		EASTWARD	
STATION NUMBER	LENGTH OF SIDINGS	Timetable No. 7		MILE POST	RULE 6(B)
	FEET	STATIONS			
26-008	2805	UCON	YL	0.0	P
262-03	880	COLTMAN (SPUR-E) YL		2.6	
262-05	825	GRANT (SPUR-E) YL		4.6	
262-07	770	BARLOW YL		6.8	
262-09	1045	LEWISVILLE YL		8.7	
262-10	880	MIDWAY YL		9.6	
262-11	1815	MENAN YL		10.4	

Trackage retired between Menan MP 10.8 and Edmonds MP 26.5

**ST. ANTHONY BRANCH**

262-27	825	EDMONDS	YL	26.7	
262-29	495	EGIN	YL	29.2	
262-34	880	PARKER	YL	33.3	
262-35	220	PYKE (SPUR-E)	YL	35.2	
26-037	5225	D	ST. ANTHONY	38.5	PY
			(22.8)		

West Belt Branch yard limits are continuous from MP 0.0 to 10.4 and St. Anthony Branch yard limits from 26.7 to 38.5.

**IDAHO DIVISION — Fourth Subdivision Branches**
**SPEED RESTRICTIONS — WEST BELT BRANCH AND ST. ANTHONY BRANCH**

LOCATION	MPH	LOCATION	MPH
Maximum speed	20	Highway Crossing 37.44	5
Cars exceeding gross weight of 240,000 pounds but not exceeding 263,000 lbs.			15

Westward trains are superior to trains of the same class in the opposite direction. — See Rule 72.

WESTWARD		MACKAY BRANCH		EASTWARD	
STATION NUMBER	LENGTH OF SIDINGS	Timetable No. 7		MILE POST	RULE 6(B)
	FEET	STATIONS			
99-158	3685	DN-R	BLACKFOOT YL	0.0	PY
256-02	4675	COLLINS YL		2.9	
256-03	495	AIKEN YL		3.8	
256-04	330	CLARKSON YL		4.3	
256-05	1430	MORELAND YL		5.6	
256-07		ABERDEEN JCT. YL		7.1	
256-08	165	ROUSE (SPUR-E)		7.6	
256-16	605	OLSEN (SPUR-E)		15.9	
256-19	495	FULLMER (SPUR-E)		18.8	
256-20	1540	TABER		20.1	
256-40	1650	SCOVILLE		39.7	Y
256-59	1760	D	ARCO	59.1	PY
			(59.45)		

Mackay Branch yard limits are continuous from MP 0.0 to MP 7.1

**SPEED RESTRICTIONS — MACKAY BRANCH**

LOCATION	MPH	LOCATION	MPH
Between Blackfoot and MP 60.0	25	Cars exceeding gross weight 240,000 pounds between Blackfoot and MP 59.45	15
Spurs at Collins	10		
Aberdeen Jct. Turnout	15		

**IDAHO DIVISION — Fourth Subdivision Branches**

WESTWARD		TETON VALLEY BRANCH		EASTWARD	
STATION NUMBER	LENGTH OF SIDINGS	Timetable No. 7		MILE POST	RULE 6(B)
	FEET	STATIONS			
26-051	2145	D-R	ASHTON YL	0.0	PY
265-02	880		MARYSVILLE	1.7	
265-06	1540		GRAINVILLE	6.0	
265-09	1045		DRUMMOND	8.5	
265-13	550		FRANCE	12.7	
265-16	1540		LAMONT	15.7	
265-22	550		JUDKINS (SPUR-W)	22.2	
265-26	990		FELT	26.2	
265-30	1045		TETONIA	30.3	PY
			(30.8)		

**SPEED RESTRICTIONS — TETON VALLEY BRANCH**

LOCATION	MPH	LOCATION	MPH
Maximum speed	25	Between Mile Posts —	
Bridges 4.52, 6.98 and 19.97	12	19.0 and 19.3	15
		25.0 and 25.4	15

Westward trains are superior to trains of the same class in the opposite direction. — See Rule 72.



I  
D  
D  
I  
V  
I  
S  
I  
O  
N

I  
D  
D  
I  
V  
I  
S  
I  
O  
N

# BRITISH COLUMBIA

CANADA  
UNITED STATES

# WASHINGTON

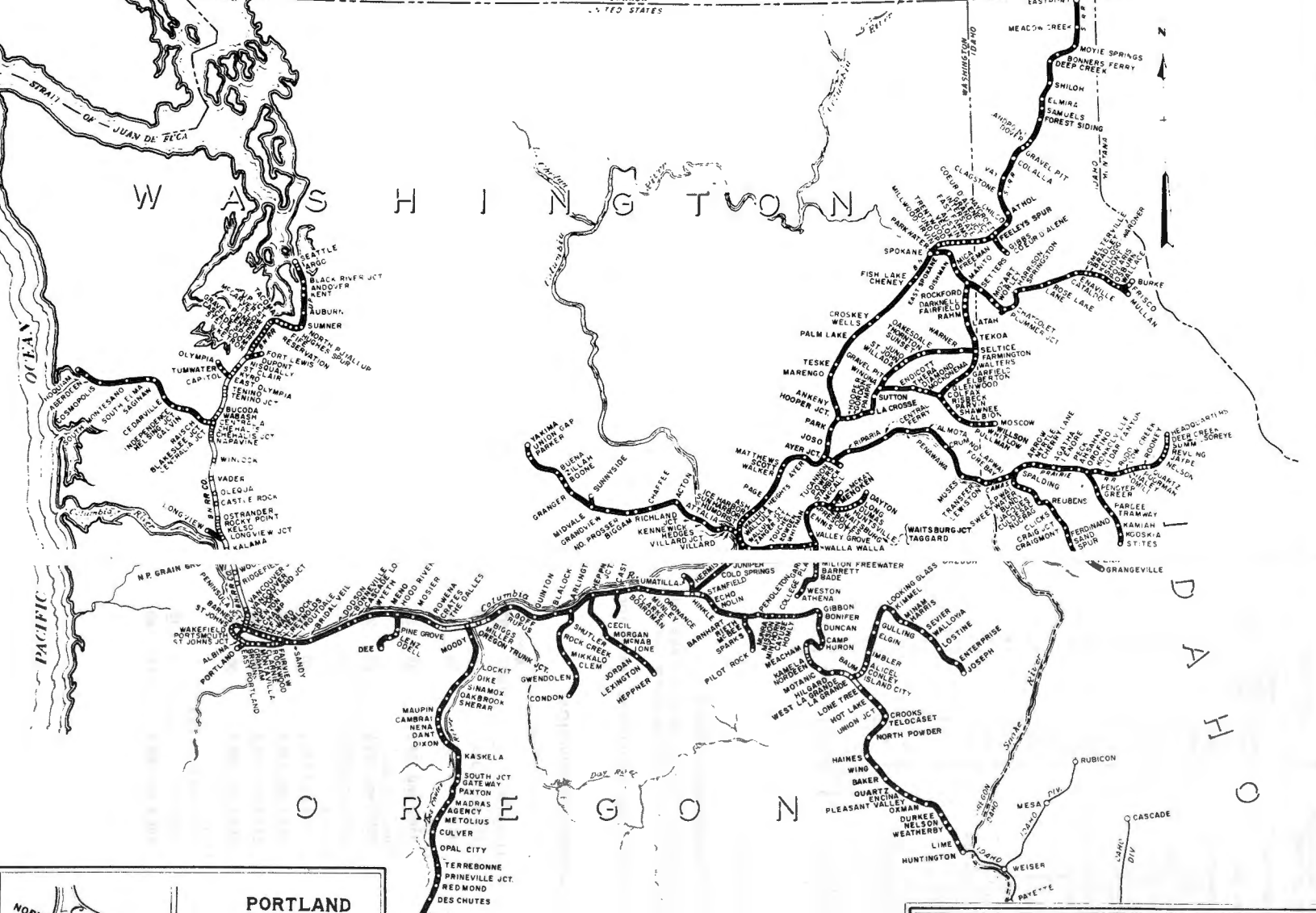

-116-

-117-

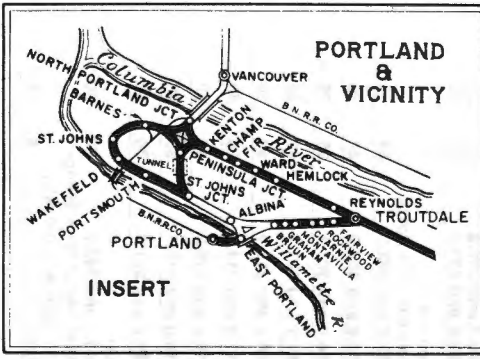

UNION PACIFIC RAILROAD  
**NORTHWESTERN DISTRICT**  
**OREGON DIVISION**

SCALE OF MILES

10 0 10 20 30 40 50 100

OFFICE OF CHIEF ENGINEER - OMAHA, NEBR  
 C.DRAWING NO 82741

**OREGON DIVISION**

WESTWARD			FIRST SUBDIVISION (MOUNTAIN TIME)		EASTWARD			
STATION NUMBER	LENGTH OF SIDINGS FEET	FIRST CLASS — 25 DAILY	Timetable No. 7			MILE POST	FIRST CLASS — 26 DAILY	RULE 6(B)
			STATIONS					
1386	8295	8.20AM	D-R	HUNTINGTON	389.8	A8.30PM	P	
1391	5215			5.5 LIME	384.3		P	
1398	8510			6.9 WEATHERBY	377.4		P	
1403	2875			8.8 NELSON	372.6		P	
1407	9960			3.9 DURKEE	368.7		P	
1414	8339			7.4 OXMAN	361.3		P	
1420	6535			6.1 PLEASANT VALLEY	355.2		P	
1424	10245			3.3 ENCINA	351.9		P	
1428	5270			4.4 QUARTZ	347.5		P	
1434	10495	s9.40	D	5.7 BAKER	341.8	s7.25	PY	
1438	5190			4.1 WING	337.7		P	
1444	8633			5.5 HAINES	332.2		P	
1453	8460			10.0 NORTH POWDER	322.3		P	
1463	7210			9.7 TELOCASET	312.6		PY	
1467	8456			4.1 CROOKS	308.5		P	
1473	5240			2.8 UNION JCT.	302.5		PY	
1477				7.4 HOT LAKE (SPUR-E)	299.7			
1481				4.3 LONE TREE	295.3		P	
				0.9 CP291	291.0		P	
1486	A10.45AM		DN-R	LA GRANDE	290.1	6.25PM	FPTY	

Note 2 to Rule 99 is in effect on First Subdivision.

**CLEARANCE AND REGISTER REQUIREMENTS**

Trains enroute to Idaho Division must receive Idaho Division clearance in addition to Oregon Division clearance at La Grande and need not receive clearance at Huntington.

Only trains which originate or terminate at Huntington need receive clearance or register at Huntington.

**SPEED RESTRICTIONS — FIRST SUBDIVISION**

LOCATION	MPH		LOCATION	MPH	
	PSGR	FRT		PSGR	FRT
Maximum Speed	70	70	343.6 and 345.1	50	50
La Grande			346.9 and 347.2	70	60
No. 1 Track			Quartz		
282.5 and 288.9	25	25	348.4 and 354.5	35	30
288.9 and 291.1	20	20	Pleasant Valley		
No. 2 Track			355.9 and 364.6	30	20
285.7 and 289.8	25	25	366.2 and 366.6	70	60
289.8 and 291.1	20	20	Durkee		
Union Jct.			370.7 and 371.1	70	60
Between Mile Posts —			372.7 and 377.3	35	30
302.6 and 303.2	65	55	377.3 and 383.2	35	35
303.2 and 304.0	40	30	383.8 and 388.4	35	30
304.0 and 307.1	35	25	Lime		
307.1 and 307.7	40	30	High line track and connection.		10
308.7 and 311.9	40	30	388.4 and 389.9	45	40
311.9 and 314.3	50	40			
315.4 and 316.0	40	30			
316.0 and 319.5	30	25			
321.2 and 321.6	70	60			
Baker					
341.1 and 342.7	50	50			
West Leg of Wye, Ellingson Spur and Industry Spur.	5	5			

**OREGON DIVISION**

WESTWARD			SECOND SUBDIVISION (PACIFIC TIME)		EASTWARD			
STATION NUMBER	LENGTH OF SIDINGS FEET	FIRST CLASS — 25 DAILY	Timetable No. 7			MILE POST	FIRST CLASS — 26 DAILY	RULE 6(B)
			STATIONS					
1486		9.55AM	DN-R	LA GRANDE	290.1	A5.15PM	FPTY	
				1.1 CP289	289.0		PX	
				1.0 CP288	288.0		PX	
				2.0 CP286	286.0		PX	
1494	9295			3.8 HILGARD	282.2		P	
1500	8727			6.6 MOTANIC	275.6		P	
1504				3.5 NORDEEN	272.1		P	
1504	C6965			5.5 KAMELA	271.0		PY	
1511				MEACHAM	265.5		P	
1518	9057			3.7 HURON	258.0		P	
1522	6085			6.8 CAMP	254.3		P	
1527	8541			8.0 DUNCAN	248.5		P	
1536	8619			2.6 BONIFER	239.5		P	
1538	5090			7.3 GIBBON	236.9		PY	
1546	5765			2.4 HOMLY	229.6		P	
1548	2290			2.3 CAYUSE	227.2		P	
1551	9121			3.9 MINTHORN	224.9		P	
1555	1295			2.0 MISSION (SPUR-E)	221.0		P	
1557	5662			MUNRA	219.0		P	
1560	7935	s12.10PM	D	PENDLETON	215.7	s3.00	P	
1564	13450			3.0 RIETH	212.7		P	
1567	6390			1.1 BARNHART	208.1		P	
1577	9269			9.1 NOLIN	199.0		P	
1583	6290			6.5 ECHO	192.5		P	
				1.0 CP189	188.7			
1587				3.3 CP188	188.4		P	
1591	A12.45PM		DN-R	HINKLE	185.3	2.20PM	FPHY	

Note 2 to Rule 99 is in effect on Second Subdivision.

**SPEED RESTRICTIONS — SECOND SUBDIVISION**

LOCATION	MPH		LOCATION	MPH	
	PSGR	FRT		PSGR	FRT
Maximum Speed			214.1 and 217.6	35	35
Between Hinkle and Pendleton	70	65	217.6 and 218.9	50	45
Between Pendleton and La Grande	70	60	227.3 and 231.6	40	30
Hinkle			232.5 and 234.0	55	45
Between Mile Posts —			236.6 and 237.9	35	25
CP 182 and CP 189			238.2 and 239.3	50	40
Main Track No. 1	40	40	239.7 and 242.0	25	25
Main Track No. 2	70	70	242.4 and 243.3	55	45
182.0 and 184.4	60	50	244.0 and 244.8	45	35
184.4 and 189.0	60	50	245.7 and 246.1	55	45
Mikami Spur		10	247.3 and 257.2	35	30
Echo			257.2 and 282.0	25	20
Over street crossings.	50	50			
191.8 and 192.2	50	50	La Grande		
193.4 and 194.5	50	40	No. 1 Track		
195.4 and 195.6	55	45	282.5 and 288.9	25	25
196.7 and 198.2	55	45	288.9 and 291.1	20	20
200.7 and 201.6	60	50	No. 2 Track		
202.3 and 204.5	55	45	285.7 and 289.8	25	25
205.3 and 206.2	65	55	289.8 and 291.1	20	20
206.7 and 206.9	60	50			
208.9 and 210.9	55	45			
212.8 and 214.1	50	40			
Rieth Siding					
213 and 213.3	20	20			

# OREGON DIVISION

WESTWARD		THIRD SUBDIVISION			EASTWARD			
STATION NUMBER	LENGTH OF SIDINGS FEET	FIRST CLASS 25 DAILY	Timetable No. 7			MILE POST	FIRST CLASS 26 DAILY	RULE 6(B)
			STATIONS					
1591		12.50PM	DN-R	HINKLE	TRACKS	185.3	A2.15PM	FPY
				1.3 CP184		183.7		
				2.0 CP182		182.1		
1597				3.1 ORDNANCE		178.9		P
1600	8785			3.0 MUNLEY		175.9		P
1605	6465			6.1 CLARKE		169.8		P
1612	9844			5.6 BOARDMAN		164.2		P
1617	9527			7.5 CASTLE		156.7		P
1627	9735			9.8 HEPPIER JCT.		146.9		P
1638	9962			8.2 ARLINGTON		138.7		P
1646	9747			9.9 BLALOCK		128.8		P
1652	9740			7.9 QUINTON		120.9		P
1661	10795			8.3 GOFF		112.6		P
1666	1375			3.9 RUFUS		108.7		P
1672	6402			4.9 BIGGS	DOUBLE TRACK	103.8		P
1675	2585			3.4 MILLER		100.4		X
1680				10.0 OREGON TRUNK JCT.		94.9		PX
1691		A2.15PM	DN-R	THE DALLES YL		84.9	12.45PM	FPTX
(99.6)								

### CLEARANCE AND REGISTER REQUIREMENTS

Trains to or from Heppner or Condon Branches need not receive clearance at Heppner Jct. or Arlington.

Trains enroute to Bend Branch must receive BN clearance at The Dalles.

Only trains which originate or terminate at The Dalles need register or receive clearance at The Dalles.

Rules 251 to 253 inclusive apply between Biggs and The Dalles.

Note 2 to Rule 99 is in effect on Third Subdivision.

NOTE — Distance between MP 165 and MP 166, between Boardman and Clarke is 0.36 mile.

### SPEED RESTRICTIONS — THIRD SUBDIVISION

LOCATION	MPH		LOCATION	MPH	
	PSGR	FRT		PSGR	FRT
Maximum Speed	70	70	Between Mile Posts —		
Between Mile Posts —			181.8 and 182.0	60	50
83.2 and 85.1	40	40	CP 182 and CP 189		
85.1 and 88.2	70	65	Main Track No. 1	40	40
96.5 and 97.8	70	65	Main Track No. 2		
98.8 and 99.3	60	50	182.0 and 184.4	70	70
104.5 and 104.9	70	60	184.4 and 189.0	60	50
113.4 and 114.7	70	60	Carty Industrial Lead		
			Maximum Speed		25
			0.5 and 0.7		20
			1.5 and 1.7		15
			11.7 and 11.8		10
			Hinkle		
			Mikami Spur		10
The Dalles					
Transfer Trks. 12, 13, 14 & 15					
Runaround Track					
Inbound Track					
Outbound Track					
Crossover Track to					
Runaround Tracks					10

Vicinity  
of  
Turntable

OREGON DIVISION

OREGON DIVISION

OREGON DIVISION

WESTWARD			FOURTH SUBDIVISION		EASTWARD		
STATION NUMBER	LENGTH OF SIDINGS FEET	FIRST CLASS 25 DAILY	Timetable No. 7		MILE POST	FIRST CLASS 26 DAILY	RULE 6(B)
			STATIONS				
1691		2.20PM	DN-R	THE DALLES YL	84.9	A12.40PM	FPTX
1694			ABS	CRATES YL	81.7		P
1700	8615			ROWENA	76.6		P
1706	6385			MOSIER	69.1		P
1712	5070	s2.50		HOOD RIVER	63.1	s12.15PM	P
1716	9895			MENO	58.4		P
1726	6340			WYETH	49.8		P
1733	6752	s3.20		CASCADE LOCKS	43.0	s11.45AM	P
1737				BONNEVILLE (SPUR-W)	38.0		P
1741	10635			DODSON	33.3		P
1749	6360			BRIDAL VEIL	26.7		P
1753	10560			SANDY	17.0		P
1760	2850			TROUTDALE YL	15.6		P
3-1762	2664			FAIRVIEW YL	12.9		P
3-1764	2950			ROCKWOOD YL	11.8		P
3-1768	2430			CLARNIE YL	7.8		P
3-1771	1375			GRAHAM YL	4.4		P
2-1781			DN	EAST PORTLAND YL	0.6		IPY
1760	6045			TROUTDALE VIA KENTON YL	22.0		P
1762	2210			REYNOLDS YL	20.0		P
1765	2480			HEMLOCK YL	17.0		P
1769				FIR YL	12.4		P
1775	8403			CHAMP YL	10.4		P
1775				KENTON YL	7.7		P
1776				PENINSULA JCT. YL	5.6		PY
2-1778				ST. JOHNS JCT. YL	4.0		P
2-1780			DN-R	ALBINA YL	1.6		FPT
2-1781			DN	EAST PORTLAND YL	0.6		IPY
3-1775		A4.35PM		PORTLAND YL	0.0	10.55AM	IP
				VIA GRAHAM (84.5)			
				VIA KENTON (90.9)			

CLEARANCE REQUIREMENTS

Eastward trains and engines via Graham must receive clearance at East Portland and need not receive clearance at Albina, except Amtrak trains when cleared at VC office need not receive clearance at East Portland.

Rules 251 to 253 inclusive apply between Crates and The Dalles.

Yard limits are continuous from Albina to East Troutdale via Kenton and Graham.

All westward trains moving on the Kenton Line must contact East Tower Yardmaster before passing west end of Champ.

At Portland, trains and engines are governed by Operating Rules and Special Instructions of Portland Terminal Railroad Company while using Portland Terminal Railroad Company tracks.

Between East Portland and Troutdale on the Graham Line, a train or engine which is to be met or passed by another train or engine must not clear the main track except at Bruun, Graham, Clarnie or Rockwood.

NOTE — Distance between MP 56 and MP 57, between Wyeth and Meno is 0.6 mile.

Note 2 to Rule 99 is in effect on Fourth Subdivision.

On single track eastward trains are superior to trains of the same class in the opposite direction. — See Rule 72.

OREGON DIVISION

SPEED RESTRICTIONS — FOURTH SUBDIVISION

LOCATION	MPH		LOCATION	MPH	
	PSGR	FRT		PSGR	FRT
Maximum Speed	70	65	23.8 and 24.0	50	40
Portland Union Station, on all tracks P.T.R.R.Co. Yard and through Interlocking	10	10	24.8 and 25.9	60	50
North Portland Tracks 103 and 104	10	10	Bridal Veil 27.5 and 29.4	60	50
Between Mile Posts — East Portland 0.9 and St. Johns Jct.	10	10	30.2 and 31.4	60	50
Over all curves East Portland, at either end of Willamette River Bridge and thru Interlocking 0.4	6	6	31.7 and 32.8	65	55
Via Graham Between East Portland and MP 15.9			35.5 and 37.3	55	45
Maximum Speed	60	50	38.2 and 39.9	60	50
0.9 and 2.7	35	25	41.4 and 42.5	30	25
2.7 and 5.2	35	35	42.5 and 45.0	50	40
10.8 and 12.0	55	45	45.0 and 49.0	55	45
13.2 and 13.5	50	40	49.5 and 58.5	60	55
Via Kenton Yard Track No. 2	10	10	Meno 59.4 and 63.4	50	40
Over Columbia Boulevard, near Peninsula Jct. 5.6	25	25	63.4 and 66.4	55	45
Over North Tyndall Av. 6.7	10	10	66.4 and 66.7	45	35
6.2 and 7.3	20	20	67.1 and 68.4	55	45
8.5 and 8.8	20	20	68.4 and 70.4	40	30
Troutdale 15.9 and 18.1	70	60	70.4 and 72.7	50	40
18.1 and 18.5	55	45	73.7 and 75.0	60	50
20.1 and 22.4	60	50	75.0 and 75.9	55	45
The Dalles Transfer Trks. 12, 13, 14 & 15			76.3 and 77.0	60	50
Runaround Track			77.5 and 78.2	65	55
Inbound Track			79.0 and 81.2	55	45
Outbound Track			81.2 and 83.2	60	50
Crossover Track to Runaround Tracks			The Dalles 83.2 and 85.1	40	40
			85.1 and 88.2	70	65

Vicinity of Turntable

10

OREGON DIVISION

OREGON DIVISION

# OREGON DIVISION

WESTWARD		FIFTH SUBDIVISION		EASTWARD		
STATION NUMBER	LENGTH OF SIDINGS	Timetable No. 7		MILE POST	RULE 6(A)	
	FEET	STATIONS				
1954		SEATTLE 3.1		183.1	Y	
1951		ABS	C-R ARGO 6.3	180.0	BFIJKP QTWYZ	
			MILW-PC CROSSING 0.0	173.7	IY	
1945	1300 3235		C-R BLACK RIVER 0.4	173.7	IJPY	
		CTC	BN CROSSING 1.8	173.3	I	
1943			ANDOVER 4.6	171.5		
1938	3393		KENT 5.2	166.9		
1933	4508		AUBURN 7.8	162.3		
1925	4539		SUMNER 1.6	154.5		
1924			NORTH PUWALLUP 4.9	152.9		
1919	4597		FIFE 1.3	148.0	JPY	
1917			ABS	C RESERVATION 0.2	146.7	IJPY
				BN CROSSING 0.1	146.5	U
				BN CROSSING 1.7	146.4	U
		C	UP JCT. (136.0)	144.7	IJPY	

Between Reservation and North Portland Junction, trains are governed by Operating Rules, Timetable and Special Instructions of Burlington Northern Inc.\*

1780		C	VANCOUVER 1.9	8.7	
1778		C	NORTH PORTLAND JCT. 1.2	6.8	IJPY
1776		CTC	PENINSULA JCT. 2.6	5.6	PTY
1778			ST. JOHNS JCT. 1.4	4.0	P
2-1780			C-R	ALBINA (181.5)	1.6

Note 2 to Rule 99 is in effect on Fifth Subdivision.

Rules 261 and 264 inclusive apply between Reservation and Fife.

Yard limits are continuous from Black River to Seattle, from Fife to Reservation and North Portland Jct. to Albina.

### CLEARANCE AND REGISTER REQUIREMENTS

All trains departing Albina need not receive clearance at Albina.

In addition to BN clearance, all Union Pacific eastward trains and engines, except Union Pacific switch engines going to Terminal 6, must receive UP clearance at North Portland.

In addition to BN clearance, all Union Pacific trains originating at Centralia must receive UP clearance at Centralia.

All trains must receive BN clearance at Reservation and UP Jct. (Tacoma) when entering BN trackage at those locations.

Conductors of all trains may register by register ticket per Operating Rule 83(A) at Black River.

\*Consolidated Code of Operating Rules (Edition of 1980) applies on the Fifth Subdivision. On Union Pacific tracks, all U.P. Superintendent's Bulletins, current Timetable and Special Instructions as well as the Consolidated Code, applies.

# SPEED RESTRICTIONS — FIFTH SUBDIVISION

LOCATION	MPH		LOCATION	MPH	
Maximum Speed	45		Auburn		
Between Mile Posts —			160.8 and 162.3	40	
0.9 and St. Johns Jct.	10	10	Siding (161.8 and 162.8)	20	
St. Johns Jct. and 6.8	25	25	Kent		
Via Kenton			166.0 and 171.0	40	
Yard Track No. 2	10	10	Siding (167.2 and 168.0)	20	
Over Columbia			Black River Jct.		
Boulevard, Near			173.2 and 173.9	20	
Peninsula Jct. 5.6	25	25	Through PC-UP crossover		
Over North Tyndall			switches within interlocking		
Ave. 6.7	10	10	173.7	20	
6.2 and 7.3	20	20	180.1 and 182.7	15	
8.5 and 8.8	20	20	Tacoma		
			146.0 and 146.9	15	
Tacoma			Fife Siding (147.4 and 148.5)	30	
146.0 and 146.9	15		Sumner		
			154.3 and 154.9	30	
			Siding (153.7 and 154.7)	10	
			Argo		
			Through interlocking	15	

# OREGON DIVISION

## STATION NUMBERS — FIFTH SUBDIVISION

1783 Vancouver Jct.	1838 Vader	1892 Nisqually
1794 Ridgefield	1845 Winlock	1898 Ketron
1799 Woodland	1851 Napavine	1900 Steilacoom
1807 No. Pac. Grain	1858 Chehalis	1901 West Tacoma
1809 Kalama	1862 Centralia	1903 Pioneer
1815 Longview Jct.	1864 Wabash	1906 Titlow
1-1819 Longview	1869 Bucoda	1914 McCarver St.
1819 Kelso	1872 Tenino Junction	1916 Tacoma
1820 Rocky Point	1873 Tenino	1940 Graystone Spur
1822 Ostrander	1881 East Olympia	1943 Tukwila
1828 Castle Rock	1886 Kyro	1944 Concora Pass
	1888 St. Clair	

**OREGON DIVISION**

WESTWARD					SIXTH SUBDIVISION	
STATION NUMBER	LENGTH OF SIDINGS FEET	SECOND CLASS			Timetable No. 7	
		151 Daily	859 Daily	119 Daily	STATIONS	
34-161		10.01PM		2.01PM	ABS	DN-R SPOKANE 2.5
		A10.09PM		A2.10PM		DN BN CROSSING 14.5

Between BN Crossing and Fish Lake, trains are governed by Operating Rules, Timetable and Special Instructions of Burlington Northern Inc.

		10.43PM		2.45PM	ABS	FISH LAKE 4.7
77-169	5140	10.50		2.52		CHENEY 16.8
77-151	2730				CROSKY 4.3	
77-147	6595	11.22		3.23	WELLS 6.3	
77-141	2605	11.32PM		3.33	PALM LAKE 12.0	
77-129	300				TESKE (SPUR-W) 4.1	
77-125	3700	12.01AM		4.01 <sup>298</sup>	MARENGO 13.5	
77-111	2660	12.21		4.16	ANKENY 8.0	
77-103	2065	12.33		4.25	HOOPER JCT. 5.7	
77-098	200				PARK (SPUR-W) 5.5	
77-092	6715	12.45		4.41	JOSO 4.1	
			10.30PM		AYER JCT. 3.8	
77-082		1.20	10.37	5.01	AYER 11.2	
77-072	9770	1.40	10.53	5.12	MATTHEWS 4.6	
77-068	4660				SCOTT 5.4	
77-062	9752	2.01	11.09 <sup>120</sup>	5.23	WALKER 9.8	
77-052	9710				PAGE 8.7	
77-044	4440				ASH 4.1	
77-039	1410				SUN HARBOR 1.5	
77-038	4345				HUMORIST 4.6	
77-034	3970				WALLULA HEIGHTS (SPUR-E) 2.8	
77-031	7640				DN-R WALLULA 1.7	
77-029					WALLULA JCT. 10.2	
77-019	7395				JUNIPER 10.0	
77-009	7490				COLD SPRINGS 9.1	
1591					DN-R HINKLE (189.5)	

**CLEARANCE AND REGISTER REQUIREMENTS**

No. 860 must receive Camas Prairie clearance prior to departing Wallula.

Eastward trains via Fish Lake must receive BN clearance prior to departing Wallula.

Westward trains must receive BN clearance prior to departing BN Crossing.

Conductors of the following trains may register by register ticket, per Operating Rule 83(A):

Wallula — all trains.

Eastward BN trains leaving UP tracks via east leg of wye at Wallula will register by register ticket at Attalia. Conductor of such trains will report arrival at Attalia by telephone to operator, Wallula.

**OREGON DIVISION**

SIXTH SUBDIVISION		EASTWARD				
Timetable No. 7		MILE POST	SECOND CLASS			RULE 8(B)
STATIONS			120 Daily	298 Daily	860 Daily	
ABS	DN-R SPOKANE YL	371.7	A2.25AM	A6.01PM		FIPY
	DN BN CROSSING YL	369.2	2.15AM	5.40PM		IP

Between BN Crossing and Fish Lake, trains are governed by Operating Rules, Timetable and Special Instructions of Burlington Northern Inc.

ABS	FISH LAKE	354.7	A1.45AM	A5.20PM		P
	CHENEY	350.0	1.35	5.10		P
ABS	CROSKY	333.2				P
	WELLS	328.9	1.08	4.40		P
ABS	PALM LAKE	322.6	12.59	4.30		P
	TESKE (SPUR-W)	310.6				
ABS	MARENGO	306.5	12.38	4.01 <sup>119</sup>		PY
	ANKENY	293.0	12.21 <sup>151</sup>	3.35		P
ABS	HOOPER JCT.	285.0	12.10AM	3.20		PY
	PARK (SPUR-W)	279.3				
ABS	JOSO	273.8	11.50	3.05		P
	AYER JCT.	269.7			A830PM	IP
ABS	AYER	267.9	11.40	2.45	8.25	IPY
	MATTHEWS	256.7	11.25	2.25	8.10	P
ABS	SCOTT	252.1				P
	WALKER	246.7	11.09 <sup>859</sup>	2.10	7.55	P
ABS	PAGE	236.9	10.54	1.55	7.40	P
	ASH	228.2				P
ABS	SUN HARBOR	224.1				
	HUMORIST	222.6				
ABS	WALLULA HEIGHTS (SPUR-E)	218.0				
	DN-R WALLULA YL	215.2				PY
ABS	WALLULA JCT. YL	213.5				PY
	JUNIPER	203.3				P
ABS	COLD SPRINGS	193.3				P
	DN-R HINKLE YL	184.2				FPY

Note 2 to Rule 99 is in effect on Sixth Subdivision between Hinkle and Fish Lake.

On single track, except where Rule 261 is in effect, eastward trains are superior to trains of the same class in the opposite direction. — See Rule S-71.

Rules 261 to 264 inclusive apply between west switch Joso and east switch Ayer.

Speed Restrictions for Sixth Subdivision. See next page.

Mileage Equation = MP 269.69 Equals MP 267.64.

Z-O-S-D-V-D-R-O

O-R-D-I-V-I-S-I-O-N

**OREGON DIVISION**  
**SPEED RESTRICTIONS — SIXTH SUBDIVISION**

LOCATION	MPH	LOCATION	MPH
Maximum Speed	60	239.7 and 240.1	50
Hinkle		244.5 and 245.7	45
Between Mile Posts — 184.7 and 185.1	20	248.2 and 248.5	55
183.7 and 185.1 West and East legs of Wye.	20	Between East switch Ayer and Ayer Jct.	40
Cold Springs 200.7 and 201.0	50	271.6 and 273.0	20
Juniper 209.2 and 210.2	35	275.1 and 282.2	45
210.2 and 211.7	40	286.2 and 286.5	50
Wallula Jct. 214.2 and 215.6 over manual switches	20	290.7 and 291.1	50
Wallula Wallula siding 213.5 and 215.0	20	291.9 and 292.3	35
219.7 and 220.0	40	294.4 and 294.5	45
221.6 and 222.0	50	295.4 and 297.0	50
Humorist 226.7 and 227.0	50	305.6 and 305.9	40
Ash 229.3 and 229.6	50	Marengo 308.6 and 309.0	50
230.6 and 232.3	35	Cheney 350.0 and 351.8. Over street crossings.	35
234.2 and 234.6	50	352.8 and 353.5	45
235.4 and 236.0	45	Fish Lake MP 354.7 through turn-out.	30
238.4 and 239.0	45	BN Crossing Through interlocking MP 369.2	10
		Over street crossings between BN Crossing MP 369.2 and Spokane MP 371.7	20

WESTWARD		SPOKANE SUBDIVISION			EASTWARD			
STATION NUMBER	LENGTH OF SIDINGS FEET	SECOND CLASS 9 DAILY	Timetable No. 7			MILE POST	SECOND CLASS 8 DAILY	RULE 6(B)
			STATIONS					
88-141	3990	9.01AM	D-R	EASTPORT	YL	140.8	A8.45PM	PY
88-126	2205	9.30		MEADOW CREEK		126.5	6.27	
88-120	690			MESENBRINK (SPUR-E)		119.8		
88-119	1730	9.51		MOYIE SPRINGS		119.2	6.08	
88-110	2270	10.50	D	BONNERS FERRY	YL	109.6	5.45	PY
				BN CROSSING	YL	109.3		
88-104	1110	11.04		DEEP CREEK		103.7	5.22	
88-096	4615	11.18		SHILOH		95.8	5.07	
88-090	2825	11.28		ELMIRA		90.2	4.57	
88-087	2205	11.33		SAMUELS		86.8	4.52	
88-082	2830	11.41		FOREST SIDING		82.1	4.44	
	4900	12.28PM	D-R	(BN Crossing) SANDPOINT	YL	74.7	4.32	IPY
88-072	2445	12.36		DOVER (SPUR-W)		71.5	4.17	
88-058	8615	1.03		VAY		57.7	3.50	
88-050	6200	1.15		CLAGSTONE		49.6	3.39	
88-043	2260	1.28		ATHOL		42.7	3.27	
88-037	1900	1.36		CHILCO		36.2	3.19	
88-027	200			HAYCROFT (SPUR-E)		26.6		
88-026	1730	1.51		COEUR D'ALENE JCT.		25.5	3.04	Y
88-022	2690	1.57		GRAND JCT. (BN Crossing)		22.0	2.57	
88-021	420			INTERSTATE (SPUR-W)		20.2		
88-018	2645	2.05		EAST FARMS		17.7	2.50	
88-013	2070			AUSTIN (SPUR-E)	YL	12.7		
88-012	1735	2.18	D	TRENTWOOD-VELOX	YL	10.8	2.38	PY
88-009	475	2.30*		MILLWOOD-IRVIN	YL	6.8	2.30*	
88-003	2190	2.40		SPOKANE SHOP	YL	2.7	2.20	
88-000		2.50		BN CROSSING	YL		2.10PM	IP
34-163		A3.01PM	D-R	SPOKANE	YL		2.01PM	FIPY
				(139.7)				

Eastward trains are superior to trains of the same class in the opposite direction. See Rule S-71.

**SPEED RESTRICTIONS — SPOKANE SUBDIVISION**

LOCATION	MPH	LOCATION	MPH
Maximum Speed	40	Deep Creek	
Between Mile Posts — BN Interlocking Limits.	10	105.4 and 105.9	35
22.0 (BN Crossing Frog)	15	109.9 (Bridge)	5
Clagstone (Siding)	10	109.0 and 110.2	15
Vay		110.2 and 116.7	20
60.0 and 68.8	35	116.7 and 117.4	15
68.8 and 69.4	25	117.4 and 123.7	20
Forest Siding		123.7 and 124.2	15
83.2 and 85.9	35	124.2 and 130.5	30
Elmira		132.7 and 133.5	30
92.6 and 96.6	35	133.5 and 139.1	35
Shiloh			
96.6 and 100.4	30		

Trains handling Canadian Pacific jumbo type equipment, series 382 M to 387 M inclusive, must not exceed 10 MPH at the following locations.

109.5 to 110.0	116.7 to 117.6
113.0 to 113.8	120.2 to 122.0
114.5 to 115.8	123.7 to 124.8

If excessive lateral movement is observed at other than restricted points speed will be immediately reduced until this motion stops.

These instructions do not apply to square type hoppers in this series.

**OREGON DIVISION — Second Subdivision Branches**

WESTWARD		PILOT ROCK BRANCH (PACIFIC TIME)		EASTWARD	
STATION NUMBER	LENGTH OF SIDINGS	Timetable No. 7		MILE POST	RULE 6(B)
	FEET	STATIONS			
1564	13450	RIETH		0.0	P
301-03	185	2.1 McBEE (SPUR-E)		2.1	
301-07	1170	3.9 SPARKS		6.0	
301-15	975	8.0 PILOT ROCK		14.0	
		(14.0)			

Movements on Pilot Rock Branch are governed by Staff System. Staff located in staff box adjacent to Junction Switch at Rieth. See Special Rule 300(R).

**SPEED RESTRICTIONS — PILOT ROCK BRANCH**

LOCATION	MPH	LOCATION	MPH
Maximum Speed	25	6.9 and 7.1	20
Between Mile Posts — 0.0 and 0.7	15	10.7 and 11.3	15
		13.0 and End of Track	15

WESTWARD			JOSEPH BRANCH (PACIFIC TIME)		EASTWARD		
STATION NUMBER	LENGTH OF SIDINGS	SECOND CLASS	Timetable No. 7		MILE POST	SECOND CLASS	RULE 6(B)
	FEET	305 Monday Wed. Friday	STATIONS			304 Sunday Tuesday Thurs.	
300-84	1960	10.01 AM	R	JOSEPH YL	83.3	A 1.50 PM	Y
300-78	1655	10.10		ENTERPRISE	77.6	1.25	
300-68	1885	10.35		LOSTINE	67.5	12.50	
300-80	2405	11.01		WALLOWA	59.5	12.25 PM	Y
300-48	300			HARRIS	48.0		
300-47	720	11.30		MINAM	46.7	11.55 AM	
300-40	3940	12.05 PM		KIMMELL	39.4	11.25	
300-34	2080	12.20		LOOKING GLASS	33.6	11.05	
300-25	1650	12.50		GULLING	24.9	10.35	
300-21	1805	1.30		ELGIN YL	20.6	10.20	Y
300-12	950	1.55		IMBLER	12.0	9.55	
300-08	995	2.10		ALICEL	8.1	9.40	
300-06	360			CONLEY	5.6		
300-04	2000			BAUM YL	3.7		
300-03	300			ISLAND CITY YL	2.2		
1486		A2.50 PM	DN-R	LA GRANDE YL	0.0	9.01 AM	FPTY
				(83.3)			

Joseph Branch yard limits are continuous from MP 0.0 to MP 4.75.

Eastward trains are superior to trains of the same class in the opposite direction. — See Rule 72.

**SPEED RESTRICTIONS — JOSEPH BRANCH**

LOCATION	MPH	LOCATION	MPH
Maximum Speed	40	64.4 and 65.2	20
Between Mile Posts — 0.0 and 0.3	15	67.0 and 67.1	30
15.6 and 19.1	15	69.9 and 70.6	30
21.1 and 21.9	20	71.8 and 72.8	25
23.6 and 25.6	20	75.0 and 81.8	25
25.6 and 56.0	15	82.5 and 83.6	15

**OREGON DIVISION — Third Subdivision Branch**

WESTWARD		UMATILLA BRANCH		EASTWARD	
STATION NUMBER	LENGTH OF SIDINGS	Timetable No. 7		MILE POST	RULE 6(B)
	FEET	STATIONS			
1591		DN-R	HINKLE YL	0.0	FPY
349-04	4675		4.1 HERMISTON YL	4.1	
349-11			6.1 UMATILLA YL	10.2	Y
			(10.2)		

Umatilla Branch yard limits are continuous from MP 0.0 to End of Branch.

**SPEED RESTRICTIONS — UMATILLA BRANCH**

LOCATION	MPH	LOCATION	MPH
Maximum Speed	20	Hermiston	
Between Mile Posts — 0.0 and 0.1	10	Street Crossing. 3.8	10
2.3 and 3.7	15	10.2 to End of Track	10

**OREGON DIVISION — Fourth Subdivision Branches**

WESTWARD		BEND BRANCH		EASTWARD	
STATION NUMBER	LENGTH OF SIDINGS	Timetable No. 7		MILE POST	RULE 6(A)
	FEET	STATIONS			
1680		OREGON TRUNK JUNCTION		0.0	JPXY

Between Oregon Trunk Junction and Bend, trains are governed by Operating Rules, Timetable and Special Instructions of Burlington Northern Inc.

STATION NUMBER	LENGTH OF SIDINGS	STATIONS	MILE POST	RULE 6(A)
32-151		C-R BEND	150.0	BFJKP TWYZ
		(150.0)		

Bend Branch shown for information only.

Station Nos. (Distance from Oregon Trunk Jct.)	STATIONS	
1680 Oregon Trunk Jct. ....	Ore.	32-070 Dixon .....
32-005 Moody .....	Ore.	32-073 Dant .....
32-017 Lockit .....	Ore.	32-080 Kaskela .....
32-026 Dike .....	Ore.	32-085 South Junction .....
32-029 Sinamox .....	Ore.	32-093 Gateway .....
32-039 Oakbrook .....	Ore.	32-099 Paxton .....
32-047 Sherar .....	Ore.	32-104 Madras .....
32-054 Maupin .....	Ore.	32-107 Agency .....
32-054 Cambrai .....	Ore.	32-109 Metolius .....
32-063 Nena .....	Ore.	32-114 Culver .....
		32-121 Opal City .....
		32-129 Terrebonne .....
		32-132 Prineville Jct. ....
		32-134 Redmond .....
		32-143 Des Chutes .....
		32-151 Bend .....

OREGON DIVISION

OREGON DIVISION

**OREGON DIVISION — Fourth Subdivision Branches**

WESTWARD		HEPPNER BRANCH	EASTWARD	
STATION NUMBER	LENGTH OF SIDINGS		Timetable No. 7	MILE POST
	FEET	STATIONS		
302-45	2260	HEPPNER	45.2	P
302-36	1210	8.9 LEXINGTON	36.3	
302-31	443	5.3 JORDAN	31.0	
302-28	890	2.7 IONE	28.3	
302-25	195	3.1 McNAB	25.2	
302-20	805	5.4 MORGAN	19.8	
302-14	330	5.2 CECIL	14.6	
1627	9735	14.6 HEPPNER JCT.	0.0	P
		(45.2)		

Movements on Heppner Branch are governed by Staff System. Staff located in staff box adjacent to junction switch at Heppner Jct. See Special Rule 300(R).

**SPEED RESTRICTIONS — HEPPNER BRANCH**

LOCATION	MPH	LOCATION	MPH
Maximum Speed	25	17.9 and 19.0	20
Between Mile Posts — 0.0 and 0.3	15	20.7 and 22.7	15
16.0 and 16.2	20	31.5 and 31.7	20
		44.7 and end of track	15

WESTWARD		CONDON BRANCH	EASTWARD	
STATION NUMBER	LENGTH OF SIDINGS		Timetable No. 7	MILE POST
	FEET	STATIONS		
303-45	1410	CONDON	44.5	Y
303-37	1250	8.2 GWENDOLEN	36.3	
303-29	1490	7.7 CLEM	28.6	
303-25	1490	4.2 MIKKALO	24.4	
303-16	635	8.4 ROCK CREEK	16.0	
303-08	1465	8.7 SHUTLER	7.3	
1638	9960	7.3 ARLINGTON	0.0	P
		(44.5)		

Movements on Condon Branch are governed by Staff System. Staff located in staff box in register building under freeway overhead at Arlington. See Special Rule 300(R).

**SPEED RESTRICTIONS — CONDON BRANCH**

LOCATION	MPH	LOCATION	MPH
Maximum Speed	25	25.5 and 25.8	15
Between Mile Posts — 0.0 and 0.4	15	27.8 and 28.9	15
15.4 and 16.1	20	29.9 and 31.3	20
16.1 and 18.6	15	33.0 and 33.4	15
On Descending Grade Between — 19.2 and 16.1	15	33.8 and 24.4	15
21.2 and 22.0	15	34.3 and 35.2	15
		44.0 and End of Track	15

**OREGON DIVISION — Fifth Subdivision Branches**

WESTWARD		GRAYS HARBOR BRANCH	
STATION NUMBER	LENGTH OF SIDINGS	Timetable No. 7	
	FEET	STATIONS	
1862		C-R	<b>CENTRALIA</b> 2.4

Between Blakeslee Junction and Centralia, trains are governed by Operating Rules, Timetable and Special Instructions of Burlington Northern Inc.

306-02			<b>BLAKESLEE JUNCTION</b> 0.0
			BN CROSSING 0.0
			MILW CROSSING 0.8
306-03	395		RAISCH 1.9
306-05	1330		GALVIN 8.6
306-14	2650		INDEPENDENCE 8.3
306-22	2690		CEDARVILLE 9.2
306-31	2325		SAGINAW 1.4
306-33	1120		SOUTH ELMA 10.0
306-42	2720		<b>SOUTH MONTESANO</b> 8.6
306-51	1895		COSMOPOLIS 2.0
306-53			SOUTH ABERDEEN JCT. 0.1
			BN CROSSING 0.6
306-54		O-R	<b>ABERDEEN</b> 3.6

Between Aberdeen and Hoquiam, trains are governed by Operating Rules, Timetable and Special Instructions of Burlington Northern Inc.

306-58		O-R	<b>HOQUIAM</b> (57.5)
--------	--	-----	--------------------------

**SPEED RESTRICTIONS — GRAYS HARBOR BRANCH**

LOCATION	MPH	LOCATION	MPH
Maximum Speed	40	50.9 and 52.1. When handling logs.	8
Between Mile Posts — 1.0 and 1.3	15	Aberdeen	
4.3 and 7.5	25	52.1 and 52.7. City Limits.	20
6.7 and 12.1	25	52.7 and 56.7. Street Crossings.	10
14.0 and 15.3	20	53.1 Boone St. Crossing.	5
15.3 and 19.8	25	54.8 Aberdeen Drawbridge	5
32.9 and 49.8	25		

**OREGON DIVISION — Fifth Subdivision Branches**

GRAYS HARBOR BRANCH		EASTWARD	
STATION NUMBER	LENGTH OF SIDINGS	Timetable No. 7	
	FEET	MILE POST	RULE 6(A)
C-R		0.0	BJJK TWYZ

Between Blakeslee Junction and Centralia, trains are governed by Operating Rules, Timetable and Special Instructions of Burlington Northern Inc.

		2.4	JMY
		2.4	M
		2.4	M
		3.2	
		5.1	
		13.7	
		22.0	
		31.2	
		32.6	
		42.6	TY
		51.2	Y
		53.2	JY
		53.3	UY
O-R		53.9	YZ

Between Aberdeen and Hoquiam, trains are governed by Operating Rules, Timetable and Special Instructions of Burlington Northern Inc.

O-R	<b>HOQUIAM</b>	57.5	
	(57.5)		

Eastward trains are superior to trains of the same class in the opposite direction. — See Rule S-71.

WESTWARD		OLYMPIA BRANCH		EASTWARD	
STATION NUMBER	LENGTH OF SIDINGS	Timetable No. 7		MILE POST	RULE 6(A)
	FEET	STATIONS			
1881		<b>EAST OLYMPIA</b> 1.9		0.0	JTY
309-02		CAPITO (SPUR-E) 2.9		1.9	Y
309-05		TUMWATER 2.5		4.8	Y
		BN CROSSING 0.1		7.3	Y
390-07		O-R	<b>OLYMPIA</b> (7.4)	7.4	BJKT WYZ

Olympia Branch yard limits are continuous from MP 0.0 to End of Branch.

**SPEED RESTRICTIONS — OLYMPIA BRANCH**

LOCATION	MPH	LOCATION	MPH
Maximum Speed	20	Tumwater	
Between Mile Posts — 0.0 and 0.2	10	5.0 and 5.8	15
		5.8 and 7.3	10
		7.3 and End of Track	6

**OREGON DIVISION — Sixth Subdivision Branches**

WESTWARD		WALLULA BRANCH		EASTWARD	
STATION NUMBER	LENGTH OF SIDINGS	Timetable No. 7		MILE POST	RULE 6(B)
	FEET	STATIONS			
346-47		D-R	WALLA WALLA YL	30.8	PY
333-29	375		COLLEGE PLACE YL	28.9	
			W.W.V.RY. CROSSING	28.7	
333-28	520		GARRETT	28.6	
333-24	590		WHITMAN	24.0	
333-19	1550		LOWDEN	19.4	
333-15	6165		TOUCHET	15.3	
333-04			ZANGAR JCT.	3.8	IP

Between Zanger Jct. and Wallula Jct. trains are governed by Operating Rules, Timetable and Special Instructions of Burlington Northern Inc., except will be governed by Union Pacific R.R. Block and Interlocking Signal Indications.

		WALLULA JCT. YL		IPY	
77-029				0.0	
			(30.8)		

**CLEARANCE REQUIREMENTS**

Eastward trains to Wallula Jct. must receive clearance at Wallula and all trains need not receive clearance at Zanger Jct.

**SPEED RESTRICTIONS — WALLULA BRANCH**

LOCATION	MPH	LOCATION	MPH
Maximum Speed	40	12.6 and 13.6	35
Between Mile Posts — 3.8 and 4.7	25	18.5 and 19.1	25
4.7 and 9.7	15	24.5 and 24.6	35
9.7 and 12.1	25	26.5 and 26.6	35
12.1 and 12.6	15	28.7 — W.W.V. Ry. Crossing	12

WESTWARD		SUNNYSIDE BRANCH		EASTWARD	
STATION NUMBER	LENGTH OF SIDINGS	Timetable No. 7		MILE POST	RULE 6(B)
	FEET	STATIONS			
334-64	1960		MIDVALE YL	0.0	Y
335-03			SUNNYSIDE YL	2.8	
			(2.8)		

Sunnyside Branch yard limits are continuous from MP 0.0 to End of Branch.

**SPEED RESTRICTION — SUNNYSIDE BRANCH**

LOCATION	MPH
Maximum Speed	20

**OREGON DIVISION — Sixth Subdivision Branches**

WESTWARD		PENDLETON BRANCH		EASTWARD	
STATION NUMBER	LENGTH OF SIDINGS	Timetable No. 7		MILE POST	RULE 6(B)
	FEET	STATIONS			
346-79	345		McKAY YL	78.6	
346-76	1200		MENOKEN YL	75.5	
346-72	1355		BOLLES YL	71.3	
346-70	55		McCALL	69.4	
346-67	1310		PRESCOTT	66.7	
346-62	410		ENNIS	60.9	
346-54	1105		VALLEY GROVE	53.6	
			BN CROSSING	47.2	
346-47		D-R	WALLA WALLA YL	46.8	PY
			W.W.V.RY. CROSSING	44.2	
346-41	1415		SPOFFORD	39.9	
			W.W.V.RY. CROSSING	36.3	
346-37	1900		MILTON-FREEWATER YL	36.1	
	600		BARRETT	33.1	
346-31	730		BADE	30.2	
346-22	3400		WESTON	20.8	
346-18	1055		ATHENA	17.0	
			(61.6)		

Pendleton Branch yard limits are continuous from Bolles to End of Branch at McKay.

Eastward trains are superior to trains of the same class in the opposite direction. — See Rule S-71.

**SPEED RESTRICTIONS — PENDLETON BRANCH**

LOCATION	MPH	LOCATION	MPH
Maximum Speed	25	W.W.V.Ry. Crossing, MP 36.3	10
Between Mile Posts — Athena		W.W.V.Ry. Crossing, MP 44.2	15
17.0 and 17.9 Over street crossings.	15	45.1 and 48.2 Over street crossings.	12
20.2 and 21.3	20	On West Leg of Wye	5
24.0 and 33.1 On descending grade	10	52.7 and 53.4	15
24.0 and 26.2	15	64.8 and 66.3	15
28.3 and 33.4	15	71.4 and 76.1	10
Milton-Freewater 35.8 and 36.8. Over street crossings.	15	78.4 to end of track	10

**OREGON DIVISION — Sixth Subdivision Branches**

WESTWARD			YAKIMA BRANCH			EASTWARD		
STATION NUMBER	LENGTH OF SIDINGS FEET	SECOND CLASS 363 Daily	Timetable No. 7			MILE POST	SECOND CLASS 364 Daily	RULE 6(B)
			STATIONS					
334-98		8.01PM	D-R	YAKIMA	YL	98.0	A2.45AM	FY
334-96	300	8.10		UNION GAP (SPUR-W)	YL	94.9	2.35	
				BN CROSSING		91.3		A
334-91	1100	8.20		PARKER		90.8	2.25	
				BN CROSSING		89.4		A
334-82		8.40		BUENA		81.9	2.10	
334-79	600	8:45		ZILAH	YL	78.5	2.05	
334-77	475			BOONE (SPUR-E)		76.4		
334-74	2705	8.53		GRANGER		73.7	1.57	
334-64	1960	9.10		MIDVALE		63.7	1.40	Y
334-59	2600	9.20		GRANDVIEW		57.5	1.30	
334-52	2275	9.35		NORTH PROSSER		50.7	1.15	
334-49	475			BIGGAM		48.3		
334-44	2750	9.50		CHAFFEE		43.0	1.01	
334-32	2660	10.20		ACTON		31.4	12.30	
334-20		10.40	R	RICHLAND JCT.	YL	18.8	12.05AM	
334-14	2205	10.55	D	KENNEWICK	YL	13.0	11.50PM	P
334-09	675	11.05		HEDGES	YL	8.5	11.30	Y
334-07	3675	11.15		VILLARD JCT.	YL	7.0	11.20	P
334-01	3670			ATTALIA	YL	0.6		P
77-031	7640	A11.30PM	DN-R	WALLULA	YL	0.0	11.05PM	PY
				(98.0)				

Maintenance of Way Rule 99(J) does not apply between Wallula and Richland Jct. All westward trains originating at Kennewick must receive clearance at Kennewick. Yard limits are continuous from Attalia to Wallula, and from Kennewick to Villard Jct. Slide detector signals between MP 41 and MP 42, see Special Rule 509 (RO-1). For movement over bridge MP 89.4 and crossing MP 91.3, see Special Rule 612 (RO).

**Except in Centralized Traffic Control territory, eastward trains are superior to trains of the same class in the opposite direction. — See Rule S-71.**  
**Exception — No. 363 is superior to No. 364.**

**MOVEMENT INSTRUCTIONS**

Movements on Government trackage between Richland Jct. and yard limit sign on Government trackage at MP 43.8 are governed by Staff System. Special Rule 300(R) will apply.

**SPEED RESTRICTIONS — YAKIMA BRANCH**

LOCATION	MPH	LOCATION	MPH
Maximum Speed	40	57.2 and 58.5	25
Between Mile Posts — 0.0 and 0.1	20	72.5 and 74.0	30
0.1 and 0.5	35	88.7 and 89.2	35
7.0 and 7.4	35	89.2 and 89.6	20
Bridge 7.4 and 8.0	15	89.6 and 90.1	35
8.0 and 8.5	35	91.0 and 91.7	20
		97.9 and End of Track	10
Richland Jct.		Sidings at the stations listed below:	
On Government Track between Richland Jct. and North Richland.	25	Richland	
23.1 and 23.7 (Shoofly)	10	Acton	
37.9 and 38.7	20	Benton City	
42.0 and 45.0	10	Chaffee	
(Government Yd. between Yakima River Bridge and Mem. Garden Cemetery)		North Prosser	10

**OREGON DIVISION — Sixth Subdivision Branches**

WESTWARD		DAYTON BRANCH		EASTWARD	
STATION NUMBER	LENGTH OF SIDINGS FEET	Timetable No. 7		MILE POST	RULE 6(B)
		STATIONS			
347-13	875	DAYTON	YL	13.1	Y
		DAYTON JCT.	YL	12.9	

Between Walsburg Jct. and Dayton Jct., trains are governed by Operating Rules, Timetable and Special Instructions of Burlington Northern Inc.

347-05		WAITSBURG JCT.	YL	5.2	
347-04	1235	D	WAITSBURG	3.5	
346-72	1345		BOLLES	0.0	
			(13.1)		

**SPEED RESTRICTIONS — DAYTON BRANCH**

LOCATION	MPH	LOCATION	MPH
Maximum Speed	25	0.6 and 5.2	20
Between Mile Posts — 0.0 and 0.6	15	Dayton 12.5 and End of Track	10

WESTWARD		TUCANNON BRANCH		EASTWARD	
STATION NUMBER	LENGTH OF SIDINGS FEET	Timetable No. 7		MILE POST	RULE 6(B)
		STATIONS			
350-04		STARBUCK		0.0	4.7
350-02	350	POWERS		3.1	
33-012		TUCANNON		0.0	P
				(4.7)	

**SPEED RESTRICTIONS — TUCANNON BRANCH**

LOCATION	MPH	LOCATION	MPH
Maximum Speed	25	Between Powers and Starbuck trains handling loaded C-3 covered hoppers not exceeding 263,000 lbs.	10
Between Tucannon and Starbuck Mile Posts — 3.7 and 4.0	15		

Eastward trains are superior to westward trains of the same class. — See Rule S-71.

OR DIVISION

OR DIVISION

**OREGON DIVISION — Sixth Subdivision Branches**

WESTWARD			TEKOA BRANCH	
STATION NUMBER	LENGTH OF SIDINGS FEET	SECOND CLASS		STATIONS
		859	391	
				Timetable No. 7
				Daily
				Daily Except Sat.
34-161			10.01AM	DN-R SPOKANE 2.1
34-159	2865		10.10	DISHMAN 2.4
34-150	3660		10.45	MICA 2.8
34-147	1010			FREEMAN 3.1
34-143			11.01	MANITO 3.4
34-138	1225		11.10	ROCKFORD 3.7
34-135	2170		11.20	DARKNELL 4.0
34-132	1840		11.30	FAIRFIELD 4.3
34-126	280			RAHM 4.6
34-123	1245		11.45AM	LATAH 4.9
33-116			12.01PM <sup>99c</sup>	TEKOA 5.2
33-110	720		A12.15PM	SELTICE 5.5
33-104	1440			FARMINGTON 5.8
33-098	800			WALTERS 6.1
33-095	1825			BN CROSSING 6.4
33-083	705			GARFIELD 6.7
33-077	1600			GLENWOOD 7.0
33-072	1700			COLFAX 7.3
33-068	1460			MOCKONEMA 7.6
33-065	835			DIAMOND 7.9
33-058	1480			THERA 8.2
33-052	3260			ENDICOTT 8.5
33-048	2320			WINONA 8.8
33-041	1345			SUTTON 9.1
				LA CROSSE 9.4

33-017	2690	10.01PM	R	RIPARIA 5.7
33-012	810	10.17PM		TUCANNON 4.6
		A10.30PM		AYER JCT. (129.8)

**CLEARANCE REQUIREMENTS**

Trains from connecting subdivisions need not receive clearance at Ayer Jct., or at Colfax or Winona, unless train order signal indicates Stop.

Trains from Camas Prairie at Riparia must receive UP clearance in addition to Camas Prairie clearance at Lewiston and need not receive clearance at Riparia.

Trains enroute to Camas Prairie at Riparia must receive Camas Prairie clearance in addition to UP clearance at Hinkle or Wallula.

Between Riparia and Lewiston trains will be governed by Camas Prairie R. R. Timetable and Special Rules.

**OREGON DIVISION — Sixth Subdivision Branches**

TEKOA BRANCH		EASTWARD			
STATIONS	MILE POST	SECOND CLASS			RULE 6(B)
		378	392	860	
Timetable No. 7					
Daily					
Daily Except Sat.					
DN-R SPOKANE	YL 161.0		A 1.40PM		FIPY
DISHMAN	YL 158.9		1.35		I
MICA	149.7		1.20		
FREEMAN	146.9				
MANITO	143.6		1.10		
ROCKFORD	138.4		12.55		
DARKNELL	135.1		12.45		
FAIRFIELD	131.7		12.35		
RAHM	126.6				
LATAH	123.3		12.15		
TEKOA	YL 116.1		12.01PM <sup>99i</sup>		Y
SELTICE	110.5		11.01AM		
FARMINGTON	104.5		10.40		
WALTERS	98.6				
BN CROSSING	95.4				
GARFIELD	95.1		10.15		
GLENWOOD	83.6				
COLFAX	YL 77.7	A4.15PM	9.30AM		PY
MOCKONEMA	72.5	4.01			
DIAMOND	68.5	3.55			
THERA	64.8				
ENDICOTT	57.9	3.40			
WINONA	YL 52.3	3.30PM			Y
SUTTON	48.0				
LA CROSSE	41.5				Y

RIPARIA	YL 17.5		A9.10PM	P
TUCANNON	11.8		8.50	PY
AYER JCT.	7.2		8.30PM	IP
	(129.8)			

Note 2 to Rule 99 is in effect on Tekoa Branch between Spokane and Manito. Eastward trains are superior to trains of the same class in the opposite direction, except that No. 391 and No. 387 are superior to No. 392 and No. 388. — See Rule S-71.

**SPEED RESTRICTIONS — TEKOA BRANCH**

LOCATION	MPH	LOCATION	MPH
Maximum Speed	40	53.3 and 55.0	35
Ayer Jct. Turn-out MP 7.17 MP 269.69 Sixth Subdivision	25	Endicott 57.8 and 58.1 Over street crossings.	25
Between Mile Posts —		61.2 and 61.5	35
11.8 and 12.7	25	62.7 and 63.0	35
41.0 and 41.8	20	64.9 and 65.6	30
42.6 and 43.7	35	68.2 and 69.0	25
49.3 and 50.0	25	69.0 and 70.1	30
50.0 and 51.5	35	73.2 and 77.1	15
51.5 and 53.3	25		

Speed Restrictions Tekoa Branch continued on next page.

OR DIVISION

OR DIVISION

**OREGON DIVISION — Sixth Subdivision Branches**

**SPEED RESTRICTIONS — TEKOA BRANCH (Continued)**

LOCATION	MPH	LOCATION	MPH
77.1 and 78.5	12	119.6 and 123.4	25
79.8 and 81.5	25	123.4 and 124.2	20
81.5 and 82.8	20	124.2 and 125.6	25
Between Mile Posts —		127.7 and 130.6	30
82.8 and 83.1	15	Fairfield 131.7 and 131.8	
83.1 and 86.5	25	Over street crossings.	25
86.5 and 87.0	15	133.3 and 133.6	15
87.0 and 91.2	20	133.6 and 135.8	35
91.2 and 91.9	15	135.8 and 137.0	25
91.9 and 95.8	25	137.0 and 138.5	15
98.7 and 102.4	30	138.5 and 141.2	25
104.0 and 104.6	20	142.6 and 144.0	20
104.6 and 105.8	25	148.2 and 148.7	35
111.8 and 115.0	30	149.9 and 155.4	25
117.1 and 117.6	15	Between BN Crossing	
Tekoa — Tilma Spur	10	163.5 and end of track	
117.6 and 119.6	20	on line through old yard.	12

**OREGON DIVISION — Sixth Subdivision Branches**

WESTWARD			PLEASANT VALLEY BRANCH		EASTWARD		
STATION NUMBER	LENGTH OF SIDINGS FEET	SECOND CLASS 391 Daily Except Sat.	Timetable No. 7			MILE POST	RULE 6(B)
			STATIONS				
33-110	720	1.01PM		SELTICE		48.0	
344-45				WARNER		45.3	
				5.6 BN CROSSING		39.7	
344-39	1735	1.20		0.6 OAKDALE		39.1	
344-31	2250	1.50		7.8 THORNTON		31.2	
344-25	1410			5.8 SUNSET		25.4	
344-21	530			4.8 JUNO		20.8	
344-18	1455	2.30		2.5 ST. JOHN		18.3	
344-12	1415	2.50		6.8 WILLADA		11.5	
344-04	2640	3.10		4.4 GRAVEL PIT		4.4	
33-052	3260	A3.30PM		WINONA	YL	0.0	Y
				(48.0)			

No. 391 need not receive clearance at Seltice.

**SPEED RESTRICTIONS — PLEASANT VALLEY BRANCH**

LOCATION	MPH	LOCATION	MPH
Maximum Speed	40	23.0 and 25.7	30
Between Mile Posts —		25.7 and 27.8	15
0.0 and 0.2	15	27.8 and 29.7	35
1.8 and 2.2	30	29.7 and 34.4	25
5.1 and 6.0	25	34.4 and 41.3	20
6.0 and 10.4	35	41.3 and 44.6	30
13.8 and 14.0	35	44.6 and 45.1	20
15.8 and 19.3	25	45.1 and 47.5	30
19.3 and 22.7	30	47.5 and 47.9	20
22.7 and 23.0	25		

WESTWARD		CONNELL BRANCH		EASTWARD	
STATION NUMBER	LENGTH OF SIDINGS FEET	Timetable No. 7		MILE POST	RULE 6(B)
		STATIONS			
33-041		D	LA CROSSE	0.0	Y
343-05	695		4.6 PAMPA	4.6	
343-08	365		3.6 GORDON	8.2	
343-15	575		6.5 HOOPER YL	14.7	
77-103	1585		1.0 HOOPER JCT. YL	15.7	PY
			(15.7)		

**SPEED RESTRICTIONS — CONNELL BRANCH**

LOCATION	MPH	LOCATION	MPH
Maximum Speed	25	15.1 and 15.7	10
Between Mile Posts —		Hooper Jct.	
3.4 and 3.6	20	West leg of wye	5
6.6 and 7.8	15	Connell Branch 15.7	
9.3 and 9.8	20	connection to Sixth	
		Subdivision.	10

Eastward trains are superior to trains of the same class in the opposite direction. — See Rule S-71.

WESTWARD		SIERRA NEVADA BRANCH		EASTWARD	
STATION NUMBER	LENGTH OF SIDINGS FEET	Timetable No. 7		MILE POST	RULE 6(B)
		STATIONS			
345-71			BRADLEY YL	0.0	
			2.0 END OF TRACK YL	2.0	
			(2.0)		

Sierra Nevada Branch yard limits are continuous from MP 0.0 to End of Branch.

**SPEED RESTRICTION — SIERRA NEVADA BRANCH**

LOCATION	MPH
Maximum Speed	10

WESTWARD			MOSCOW BRANCH		EASTWARD			
STATION NUMBER	LENGTH OF SIDINGS FEET	SECOND CLASS 379 Daily Except Sunday	Timetable No. 7			MILE POST	SECOND CLASS 378 Daily Except Sat.	RULE 6(B)
			STATIONS					
342-28		7:30AM	D-R	MOSCOW	YL	28.1	A6.15PM	
342-26	2355			2.3 WILLSON		25.8		
342-21	315	7.55		5.3 WHITLOW		20.5	5.50	
				1.2 BN CROSSING		19.3		
342-19	1225	8.05		0.6 PULLMAN		18.7	5.40	
342-13	1155	8.25		6.0 ALBION		12.7	5.20	
342-10	1020	8.35		3.0 SHAWNEE		9.7	5.10	
342-08	525			1.9 PARVIN		7.8		
342-05	310			4.5 RISBECK		4.5		
33-077		A9.15AM	D-R	COLFAX	YL	0.0	4.30PM	PY
				(28.1)				

Eastward trains are superior to trains of the same class in the opposite direction. Exception: on Moscow Branch No. 379 is superior to No. 378. See Rule S-71.

**OREGON DIVISION — Sixth Subdivision Branches**

**SPEED RESTRICTIONS — MOSCOW BRANCH**

LOCATION	MPH	LOCATION	MPH
Maximum Speed	25	12.2 and 15.0	15
Between Mile Posts — 0.0 and 1.1	12	15.0 and 17.3	20
1.1 and 3.1	15	17.3 and 20.0	15
3.9 and 4.2	20	Pullman 18.5 and 19.5 Street Crossings.	6
5.5 and 7.5	15	24.6 and 25.4	15
8.4 and 8.8	15	26.5 and 28.5 Street Crossings.	12
9.9 and 10.6	20		
10.6 and 11.3	15		

WESTWARD		WALLACE BRANCH		EASTWARD	
STATION NUMBER	LENGTH OF SIDINGS	Timetable No. 7		MILE POST	RULE 6(B)
	FEET	STATIONS			
34-143	3373	R	MANITO YL	0.4	
345-07	1257		6.5 SETTERS	6.9	
345-12	4660		5.4 MOZART	12.3	
345-13	1480		1.2 WORLEY	13.5	
345-20			2.7 PLUMMER YL	16.2	
345-26	1220		6.6 CHATCOLET	22.8	
345-34	1000		7.1 HARRISON	30.5	
345-38	2190		3.3 SPRINGSTON	33.8	
345-49	1080		11.4 LANE	45.2	
345-53	1760		4.9 ROSE LAKE	50.1	
345-61	1535		7.3 CATALDO	57.4	
345-66	375		5.1 ENAVILLE	62.5	Y
345-71			4.7 BRADLEY YL	67.2	
345-73	1710	D-R	1.7 KELLOGG-WARDNER YL	68.9	FP
345-76			3.9 SHONT YL	72.8	
345-79	1915		3.0 OSBURN YL	75.8	
345-84		D	4.4 WALLACE YL	80.2	
345-90	360		6.7 BURKE YL	86.9	
			(90.5)		

Mileage Equation 16.2 equals B19.8 (B = Milwaukee Trackage).  
Yard Limits are continuous from MP 62.25 to Burke.  
Eastward trains are superior to trains of the same class in the opposite direction.

**SPEED RESTRICTIONS — WALLACE BRANCH**

LOCATION	MPH	LOCATION	MPH
Maximum Speed	40	47.9 and 48.9	30
Between Mile Posts — 0.0 and 0.2	20	50.6 and 50.9	30
16.2 and 16.6	10	53.6 and 54.9	30
16.6 and B23.45	20	58.8 and 60.0	35
B19.3 and B19.8	15	60.0 and 61.2	25
23.45 and 28.7	20	62.4 and 64.6	35
MP 23.45	10	Kellogg-Wardner 67.2 and 68.9 St. Crossings	10
24.0 and 28.7	20	Wallace 80.0 and 80.5 St. Crossings	6
28.7 and 31.1	35	80.5 and 87.3	15
34.0 and 35.2	30	Burke to Wallace, Eastward.	10
38.3 and 39.9	35	Mullan Industrial Lead Maximum Speed	15
43.7 and 43.9	35	Wallace Public Crossings	5
		Mullan Public Crossings	10

**OREGON DIVISION — Sixth Subdivision Branches**

WESTWARD		COEUR D'ALENE BRANCH		EASTWARD	
STATION NUMBER	LENGTH OF SIDINGS	Timetable No. 7		MILE POST	RULE 6(B)
	FEET	STATIONS			
890-09		D	COEUR D'ALENE YL	8.8	
890-08	640		1.0 GIBBS YL	7.8	
88-026	1730		7.8 COEUR D'ALENE JCT. YL	0.0	Y
			(8.8)		

Coeur D'Alene Branch yard limits are continuous from MP 0.0 to End of Branch.

**SPEED RESTRICTIONS — COEUR D'ALENE BRANCH**

LOCATION	MPH
Maximum Speed	20
Between Mile Posts — 6.8 and 7.2	10

20-5-V-D BR

OR DIVISION

## MOUNT HOOD RAILWAY

R. J. Larkin, General Manager.....	Albina, OR
J. L. Verhaal, Asst. Supt.....	Albina, OR
R. Moore, Trainmaster.....	Hinkle, OR
B. D. Nebeker, Manager.....	Hood River, OR
C. D. Rhodig, Roadfrmn/Asst. Trnmstr.....	Albina, OR
D. L. Monson, Chief Engineer.....	Albina, OR
G. D. Altenburg, General Rdmstr.....	Albina, OR
J. L. Slane, Manager of Safety.....	Albina, OR
L. L. McCormick, Chief Dispatcher.....	Albina, OR
R. L. Warner, Mech. Supt. West.....	Albina, OR
D. K. Bies, Gen. Supt. of Transp.....	Portland, OR

WESTWARD		Timetable No. 7			EASTWARD	
STATION NUMBER	LENGTH OF SIDINGS	STATIONS		MILE POST	RULE 6(B)	
1	5070	D-R	HOOD RIVER	YL 0.0	P	
			2.9 SWITCHBACK	YL 2.9		
10	1236		2.7 PINEGROVE	YL 5.6		
			1.8 LENZ	YL 7.4		
20	1299 1087		1.1 ODELL	YL 8.5		
20	911-E		6.8 DEE	YL 15.3		
			5.8 PARKDALE	YL 21.1		
55	1247 948					

Yard Limits are continuous from Hood River to Parkdale (end of track).

## SPEED RESTRICTIONS

LOCATION	MPH	LOCATION	MPH
Maximum Speed	20	7.6 and 7.8	15
Between Mile Posts 0.0 and 1.8	15	10.7 and 11.1	15
1.8 and 2.1	10	12.9 and 13.1	15
2.8 and 3.7	10	15.3 and 16.2	10
3.7 and 5.6	15	16.2 and end of track	15

## SPECIAL INSTRUCTIONS

The Mount Hood Railway will operate in accordance with operating rules as outlined in Union Pacific Railroad Company, Eastern and South-Central Districts and Idaho Division Operating Rules, effective May 1, 1972.

The following rules are also in effect on Mount Hood Railway for employees whose duties are affected:

"Union Pacific Railroad Company and Spokane International Railroad Company, Maintenance of Way and Signal Rules, effective May 1, 1972."

**Form 7160.** "Union Pacific Railroad Company Freight Car Safety Inspection Standards."

**Form 7170.** "Union Pacific Railroad Company-Spokane International Railroad Company, Rules and Instructions Governing Operation of Air Brakes, Communicating Signal System, Electric headlights, Heating, Air Conditioning, Water Systems and Lighting."

**Form 7908.** "Union Pacific Railroad Rules Governing Duties and Department of Employee's Safety Instructions and Use of Radio."

2(A) Operating Rule 2 is not in effect on the Mount Hood Railway.

## ENGINE WHISTLE SIGNALS

**14 (RM)** In addition to locations listed in Union Pacific Operating Rule 14(l), engine whistle must be sounded and bell rung approaching private crossings when view of crossing is obscured, or when it can be seen that persons or vehicles are approaching or in the vicinity of the crossing.

## SWITCH LIGHTS

**27(RNW).** Switch lights will not be used on branch lines.

Where switch lights are not used, trains and engines must approach facing point switches prepared to stop if switch is not in normal position.

## SWITCHES AND DERAILS

**104 (RM).** Switches and Derails. Main track derails are located at the following points: Milepost 7.4 and Milepost 20.75.

**104 (RM).** If cars are left on tail of switch-back, milepost 2.9 switch must be left lined for ascending grade towards Parkdale.

## CLOSE CLEARANCES

**900 (RM).** There are close side clearances for personnel riding cars or locomotives along main track at Milepost 0.40 (Bridge). Additional close clearances may be expected at platforms, buildings and other structures along any side, industry or other track.

## RETAINING VALVES

**1042 (RM).** Trains being handled on descending grades from Parkdale to Dee and from Pinegrove to switch-back must have retaining valves placed in heavy holding positions on all cars in train.

# YAKIMA VALLEY TRANSPORTATION COMPANY

R. J. Larkin, Superintendent.....	Albina, OR
J. L. Verhaal, Assistant Superintendent.....	Albina, OR
D. J. Duffy, Trainmaster.....	Hinkle, OR
J. L. Price, Manager.....	Yakima, WA
S. Brooks, Asst. Trainmaster/Road Foreman of Engines.....	Hinkle, OR
D. L. Monson, Chief Engineer.....	Albina, OR
T. R. King, General Roadmaster.....	Spokane, WA
C. A. McKenzie, Roadmaster.....	Hinkle, OR
J. L. Slane, Manager of Safety.....	Albina, OR
L. L. McCormick, Chief Dispatcher.....	Albina, OR
R. L. Warner, Mechanical Superintendent West.....	Albina, OR
D. K. Bies, Gen. Supt. of Transp.....	Portland, OR

WESTWARD	Timetable No. 7	EASTWARD	
↓	STATIONS	MILE POST	RULE 6(A)
	YAKIMA 4.5	0.0	Y
	CONGDON 0.1	4.5	Y
	WIDEHOLLOW JCT. 1.1	4.6	Y
	WESTBROOK 1.0	5.7	Y
	PIEDMONT 0.3	6.7	Y
	HARWOOD 2.7	7.0	Y
	HENRYBRO	9.7	Y

Yard Limits (Y) from Yakima are continuous to Henrybro (end of track) and on all spur tracks. Train movements will be made in accordance with Special Rule 93(R-1).

Other trackage not shown in Timetable.

Selah Spur:	M.P. 0.3 to Selah, distance 4.8 miles.
Wiley Spur:	Widehollow Jct. to Wiley, distance 4.7 miles.
Orchard Spur:	Eastman (Nobhill Blvd. and 48th Ave.) to Orchard, distance 1.2 miles.

### SPEED RESTRICTIONS

LOCATION	MPH
Maximum Speed	20
6th Avenue between Pine & Walnut Streets	5
City Streets Yakima	12

### SPECIAL INSTRUCTIONS

Yakima Valley Transportation Company will operate in accordance with operating rules as outlined in "The Consolidated Code of Operating Rules," Edition of 1980.

Following rules are also in effect on Yakima Valley Transportation Company for employees whose duties are affected:

"Union Pacific Railroad Company and Spokane International Railroad Company, Maintenance of Way and Signal Rules" effective May 1, 1972.

Form 7170 "Union Pacific Railroad Company-Spokane International Railroad Company; Rules and Instructions Governing Operation of Air Brakes, Communicating Signal System, Electric Headlights, Heating, Air Conditioning, Water Systems and Lighting."

Form 7908 "Union Pacific Railroad Company, Safety Instructions."

Trains will not operate on Yakima City streets during the following time periods Monday thru Fridays:

Location	Hours Train Prohibited
West of 6th Ave.	1:00 AM to 1:00 PM 4:30 PM to 6:00 PM
On 6th Ave.	1:00 AM to 12 Noon 4:30 PM to 6:00 PM

Within the City Limits of Yakima the following will govern: All trains and on track equipment shall obey traffic signals at intersecting streets, and shall be preceded by a flagman at intersections which are protected by stop signs. During nondaylight hours, the engine of all trains shall be lighted on all sides, and the last car of each train shall have affixed at each side of the trailing end, a flashing red light visible from the rear and respective sides of the train or cut of cars.

#### Engine Whistle Signals

**15 (YR).** In addition to locations listed in Operating Rule 15 (1), engine whistle must be sounded and bell rung approaching private crossings when view of crossing is obscured or when it can be seen that persons or vehicles are approaching or in the vicinity of the crossing.

## WESTERN DISTRICT

**C. G. YUND**  
**General Manager**  
**C. AADNESEN**  
**General Superintendent**

**A. KINICKI**  
**W. F. SCHOBBER**  
**W. P. GRIZARD**

**Manager — Operating Rules**  
**Chief Train Dispatcher**  
**Manager — Safety**

**Sacramento, Calif.**  
**Sacramento, Calif.**  
**Sacramento, Calif.**

## WESTERN DIVISION

**C. M. PITTS**  
**R. R. AHEARN**  
**R. W. RIDINGER**  
**R. L. POITRAS**  
**W. A. HILL**  
**F. D. WEBB**  
**D. L. BUCCOLO**  
**J. B. LEONARD**  
**L. M. McDONALD**  
**R. D. COX**  
**H. HAYES**  
**W. K. O'BRIEN**  
**R. L. MEYER**  
**D. E. HENKE**  
**J. S. RICH**  
**S. E. HUMPHREYS**

**Division Superintendent**  
**Division Assistant Superintendent**  
**Terminal Superintendent**  
**Terminal Trainmaster**  
**Trainmaster**  
**Terminal Trainmaster**  
**Terminal Superintendent**  
**Terminal Trainmaster**  
**Terminal Trainmaster**  
**Terminal Superintendent**  
**Terminal Trainmaster**  
**Trainmaster**  
**Trainmaster**  
**Terminal Trainmaster**  
**Trainmaster**  
**Road Foreman —**  
**Assistant Trainmaster**  
**Road Foreman Engines**  
**Road Foreman Engines**  
**Road Foreman Engines**  
**Division Engineer**  
**General Roadmaster**

**W. G. CLEVELAND**  
**J. R. SANFORD**  
**D. S. BLACK**  
**J. M. DUNN**  
**J. M. JESSEN**

**Stockton, Calif.**  
**Stockton, Calif.**  
**Oroville, Calif.**  
**Oroville, Calif.**  
**Portola, Calif.**  
**Sacramento, Calif.**  
**Sacramento, Calif.**

**Sacramento, Calif.**  
**Sacramento, Calif.**  
**Oakland, Calif.**  
**Oakland, Calif.**  
**Milpitas, Calif.**  
**Milpitas, Calif.**  
**Stockton, Calif.**  
**Stockton, Calif.**  
**Stockton, Calif.**  
**Sacramento, Calif.**  
**Sacramento, Calif.**  
**Sacramento, Calif.**  
**Oroville, Calif.**  
**Oroville, Calif.**  
**Reno, Nevada**

**Stockton, Calif.**  
**Stockton, Calif.**  
**Oroville, Calif.**  
**Oroville, Calif.**  
**Portola, Calif.**  
**Sacramento, Calif.**  
**Sacramento, Calif.**

## EASTERN DIVISION

**R. R. GENTRY**  
**G. L. BONNER**  
**G. Y. NEU**  
**G. M. CHRIST**  
**J. W. HAMMOND**  
**G. AGUIRRE**  
**M. D. MOUDY**  
**G. R. GROVES**

**Division Superintendent**  
**Trainmaster**  
**Trainmaster**  
**Trainmaster**  
**Road Foreman Engines**  
**Road Foreman Engines**  
**Division Engineer**  
**General Roadmaster**

**Elko, Nevada**  
**Winnemucca, Nevada**  
**Elko, Nevada**  
**Salt Lake City, Utah**  
**Salt Lake City, Utah**  
**Elko, Nevada**  
**Elko, Nevada**  
**Elko, Nevada**

### EASTERN DIVISION MILEAGE

**Main Track 542.8**  
**Branches 37.3**  
**Total 580.1**

### WESTERN DIVISION MILEAGE

**Main Track 487.5**  
**Branches 358.3 (includes TS and SN)**  
**Total 845.8**

WESTERN PACIFIC OPERATING RULES GOVERN ON THE WESTERN DISTRICT.

## EMERGENCY PHONE NUMBERS

In an emergency, the fastest way to get help is to dial the number yourself, or in any emergency, dial "0" for operator. When describing the emergency, be specific, particularly with respect to location. Do not use milepost numbers with outside parties unless those parties, such as the "Forest Service" are familiar with our numbers. For easy reference, number of Chief Dispatcher is 916 442-5819.

	POLICE	FIRE AND RESCUE
San Francisco .....	911	415 861-8020
Oakland .....	415 273-3211	415 444-1616
San Leandro .....	415 638-2123	415 638-2121
Hayward .....	911	911
Union City .....	911	911
Fremont .....	911	911
Milpitas .....	408 263-1212	408 998-7212
San Jose .....	408 297-3565	408 294-4664
Pleasanton .....	911	911
Livermore .....	911	911
Tracy .....	209 835-2525	911
Lathrop .....	209 944-2121	209 823-7601
Stockton .....	209 944-8383	209 464-4646
Thornton .....		209 794-2341
Elk Grove .....		916 685-9501
Sacramento .....	916 449-5151	916 449-5252
Marysville .....	916 743-5443	916 742-2424
Yuba City .....	916 673-1121	916 673-1121
Oroville .....	916 533-1221	916 533-2525
Quincy .....	916 283-0400	916 283-1221
Greenville .....	916 284-7222	916 284-7777
Westwood .....	916 256-3222	916 256-3333
Bieber .....	916 294-5421	
Graeagle .....		916 836-2110
Portola .....	916 832-4242	916 832-4343
U.S. Forest Service .....	Mohawk Ranger .....	916 836-2575
	Quincy .....	916 836-2575
	Oroville Ranger .....	916 534-6500
Reno .....	702 785-2121	702 785-2345
Herlong .....	916 827-2205	916 827-2591
Winnemucca .....	911	911
Carlin .....	702 754-6710	702 754-6710
Elko .....	702 738-4011	702 738-4011
Wells .....	702 752-3333	702 752-3333
Wendover .....	801 655-2200	801 665-2345
Grantsville .....	801 822-5600	801 884-6611
Salt Lake City .....	911	911
Emergency Heli- copter Service .....	Elko .....	702 738-4011
	Salt Lake City (Holy Cross Hospital) .....	801 350-4630
	Reno (Washoe Medical Center) .....	702 785-4340
Manteca .....	209 823-2101	209 239-1351
Escalon .....	209 838-7093	209 838-2412
Ripon .....	209 599-2102	209 599-3211
Modesto .....	209 524-4721	209 523-5656
Turlock .....	209 668-1200	209 668-1200
Pittsburg .....	415 439-4990	415 432-3515
Woodland .....	916 662-3922	916 666-4464
Chico .....	916 895-4911	916 895-4911
California Highway Patrol .....	ZE1-2000	
Sheriff/Fire/ Ambulance .....	San Joaquin County .....	209 944-2121
	Sacramento County .....	916 441-3441
	Stanislaus County .....	Sheriff .....
		209 526-6432
	Fire .....	209 524-7381

## RULE 10-I RADIO COMMUNICATION

Oral authorization and acknowledgements between Foremen and Engineers for trains to pass "Red Conditional Stop" signs must be worded in the following forms:

### Foreman's Initiation

This is UP Foreman in charge of the work between MP ..... and MP .....UP Train Order No. .... we are in the clear and you may proceed past the red conditional stop sign and through the limits of the order at ..... M.P.H.\*

### Engineer's Response

This is Engineer UP S.P. Train ..... I may proceed past the red conditional stop sign and through the limits of UP Order No. .... between MP ..... and MP ..... at (Speed)\* repeat (Speed) miles Per Hour.\*

Foreman must acknowledge Engineer's response as follows:

UP/S.P. Train ....., between MP ..... and MP ..... (Speed)\* Miles Per Hours, OK on Order No. ....

\*Foreman may authorize train to proceed "at maximum authorized speed" if no speed restriction is required account Form W train order.

## RADIO COMMUNICATION WITH UP ENGINES AND CABOOSES

The Dispatchers' Radio Control System has been modified to permit the dispatcher to communicate with crews operating Union Pacific engines and cabooses on Western district in addition to Western Pacific engines and cabooses.

The following instructions apply:

### WESTERN PACIFIC ENGINES AND CABOOSE RADIOS:

Select Channel 1.

Operate push-to-talk button one full second.

Upon release of push-to-talk, a short coded tone burst will be received from the nearest dispatchers' base station, indicating that a request has been sent to the dispatcher.

### UNION PACIFIC ENGINE AND CABOOSE RADIOS:

Select Channel "1" (or "UPR" or "UP-1").

Operate "RED" "DISPATCHER" OR "CALL" button (depending upon marking) for one full second. The CALL button activates the radio transmitter.

Upon release of the CALL button a short tone burst will be heard indicating that a request has been sent to the dispatcher.

When the dispatcher selects the station and channel to respond, a similar tone burst will be heard and the dispatcher will transmit "UP FIRST SUB DISPATCHER-OVER" (or equivalent).

The requesting party should then identify and state their business. The dispatcher will then be able to identify the crew on the next transmission.

The Dispatcher Base Stations are located as follows:

#### First and Second Subdivision

SAN CARLOS  
RADUM  
MODESTO

STOCKTON  
SACRAMENTO  
MARYSVILLE

#### Third Subdivision

OROVILLE  
PULGA  
CAMP RODGERS

VIRGILIA  
KEDDIE  
BLAIRSDEN

#### Fifth Subdivision

HAWLEY  
RED ROCK  
SAND PASS  
GERLACH

FLOKA  
EAST JUNGO  
RAGLAN

#### Sixth Subdivision

GOLCONDA  
ELLISON  
DUNPHY

PALISADE  
ELKO

#### Seventh Subdivision

(ELKO)  
DEETH  
TOBAR  
SHAFTER

WENDOVER  
BURMESTER  
SALT LAKE CITY  
(5600 WEST)

When the base station is selected, the adjacent station(s) is disabled. Wait a reasonable time before initiating another request.

**SPEED AND CAR HANDLING RESTRICTIONS**  
**All Subdivisions and Branches**  
**INCLUDING TS AND SN**

GENERAL:	Maximum MPH
Through turnouts, crossovers, on wyes, on sidings and on all inside tracks (except as otherwise provided for).....	10
On inside tracks when curvature or other conditions require, speed will be further reduced to insure safe operation.	

RULE 10-J. Freight trains do not exceed 55 MPH if train exceeds Tons Per Operative Brake in table below.

Tons Per Operative Brake	Maximum Number of Cars (Including Caboose)
80 or less	70
80+ to 85	55
85+ to 90	50
90+ to 95	45
95+ to 100	40

In the Table, 80+ tons per operative brake represents any value over exactly 80.0 (similarly for the 85+, 90+ and 95+ tons per operative brake table values).

NOTE: See "SPECIAL RULES-SYSTEM" for method of computing tons per operative brake.

Freight trains except OMW, WPV, FF, OME WPX and TOF, SP trains CPEFF, OACHT, RVNPP and RVOGP, and other trains as designated by Chief Train Dispatcher will be governed by Fuel Conservation Speeds as follows:

Maximum Speed - 45 MPH except, if not otherwise restricted, may operate at speeds up to 55 MPH (but not to exceed track speed) at locations where locomotive is in Dynamic Brake, Idle or Run 1. In undulating territory or where an individual sag is encountered, power may be worked and speed may exceed 45 MPH (but not to exceed track speed) for very short distances (generally not to exceed twice the length of the train) when pulling up the ascending side of sags to minimize slack action.

Designation of train to be excepted from observation of fuel conservation requirements by Chief Train Dispatcher may be made verbally.

Speed restrictions listed below apply to specific equipment and conditions. In addition, compliance with other applicable speed restrictions is required.

NOTE: Restrictions on cars and equipment listed herein must be respected when operating on any foreign railroad.

	Maximum MPH
Movements within the confines of car and locomotive servicing areas	5
Movements onto or off from live rails of track scales .....	5
The movement of freight cars and cabooses onto or over turntables is prohibited except by Mechanical Department personnel	

**MW EQUIPMENT**

Trains handling derricks Nos. 37 and 79 and assigned outfits, straight track.....	35
On curves 5 MPH less than speed prescribed but not exceeding ..	30
For first five miles after leaving initial terminal .....	20
On SN and TS .....	10
(On SN and TS, must have weight restriction clearance before moving for 379,000 gross weight on rail with 19'10" truck centers.)	

Trains handling derricks (other than derrick Nos. 37 and 79).....	30
Third and Fourth Subdivisions .....	25
San Jose Branch (To west switch Milpitas) .....	20
West switch Milpitas to end of Branch .....	10
Tracy Branch .....	10
Reno Branch .....	20
Loyalton Branch .....	10
Marblehead Branch .....	10
Rowley Branch .....	20
Ellerbeck Branch .....	10
Warner Branch .....	10
SN and TS .....	20

Trains handling pile drivers and cranes on their own wheels except cranes 89 and 90	
Third and Fourth Subdivisions and Branches, SN and TS .....	20
All other Subdivisions .....	25

Trains handling Cranes WPMW 89 and 90	
Third and Fourth Subdivisions and Branches, SN and TS .....	25
All other Subdivisions .....	35

**SPEED AND CAR HANDLING RESTRICTIONS CONT.**

GENERAL: (Continued)	Maximum MPH
Trains handling cranes with booms leading .....	25
Jordan Spreaders Forward Movement.....	50
When the plow end of Jordan Spreaders 6, 7 and 13 are to be coupled to other cars or engines, an empty flat car must be placed next to plow end, to prevent damage to engine or equipment.	
Spreaders in reverse movement .....	25
Trains handling air dump cars, series WP-MW 11000, loaded or empty .....	25
Air dump cars, series WPMW 11000 loaded or empty, are to be handled near caboose except when being handled in short trains, locals, etc., or for immediate set out.	
Ribbon rail train, loaded .....	40

All WPMW (Maintenance of Way) cars are restricted to a maximum speed of 30 MPH and are restricted to movement in local freight or work trains unless otherwise specifically authorized by Chief Train Dispatcher, EXCEPT the following: (Does not apply to derricks and cranes. See above for restrictions.)

WPMW 0196 thru 0199.....	(LOCO SAND)
WPMW 0211 thru 0261.....	(BOX)
WPMW 0400 thru 0410.....	(BALLAST)
WPMW 0500 .....	(RAIL FLAT)
WPMW 1201 thru 1299.....	(TANK)
WPMW 8593 thru 8599.....	(MATERIAL)
WPMW 8651 thru 8689.....	(FLAT)
WPMW 6, 7 and 13.....	(JORDAN SPREADERS)
WPMW 79-9 .....	(TIE)

System Water cars (WPMW 1063, 1070, 1132, 1556, 1575, 1577, 1579, 1581 and 1583), System Diesel Fuel Cars and Journal Oil cars (WPMW 1202, 1203, 1208, 1210, 1212, 1213, 1215, 1217, 1223, 1224, 1225, 1231, 1232, 1233, 1235, 1245, 1249 and 1250) and Supply car WPMW 0291 are restricted to rear 20 cars of train. Exception, restriction does not apply to Diesel Fuel cars and Journal Oil cars as listed above on First Subdivision. It does apply to Water cars and Supply car on all subdivisions.

**NOTE:**

Diesel Fuel cars and Journal Oil cars not listed by number are not restricted to rear 20 cars of train.

Additionally, WPMW 8004, if not moving with pile driver, is restricted to rear 20 cars of train.

Refer to applicable speed restrictions for these cars.

COILED STEEL:	
Trains handling coiled steel except in trailer on flat car.....	45
Loads of coiled steel, other than TOFC, are to be entrained on or near head end of train.	
Trains handling empty steel gons as follows: WP 4401-4425, DRGW 56344-56374 and SP 323000-323089 .....	45

**COAL AND ORE:**

Unit coal trains, loaded or empty .....	50
On SP Paired Track, see Rule 33 under All Subdivisions in SP Timetable	
Unit coal trains, loaded, Third Subdivision .....	25
Westward trains handling 60 or more cars of COAL do not exceed 20 MPH at the following locations:	
MP 295 to MP 294	
MP 283 to MP 251.52	
MP 234 to MP 232.62	

Trains handling ore in open top cars .....	55
Trains handling copper concentrates in 61 ft. or longer gondolas .....	40

**COVERED HOPPERS:**

Trains handling blocks of 10 or more covered hoppers, loaded or empty .....	45
On Third Subdivision .....	40
Westward trains handling 60 or more cars of GRAIN do not exceed 20 MPH at the following locations:	
MP 295 to MP 294	
MP 283 to MP 251.52	
MP 234 to MP 232.62	
Trains handling more than 50 covered hoppers, loaded or empty .....	40
Trains handling 76 or more loaded covered hoppers on Third Subdivision.....	25
Covered Hopper cars, loaded, series ACFX and SHPX 25000 to 25999, in movement of silica sand from Mill Creek, Oklahoma to Berkeley, California via either UP or DRGW, equipped with friction bearings .....	50
Such cars must be observed closely en route.	

**SPEED AND CAR HANDLING RESTRICTIONS CONT.**

GENERAL: (Continued)	Maximum MPH
OTHER CARS:	
Trains handling empty bulkhead flats including center beam bulkhead flats.....	45
Scale test cars on own wheels except UP903006 must be handled next to caboose and trains handling such cars will not exceed	
Between Oakland and Salt Lake City.....	35
Between Keddie and Bieber.....	25
Branches.....	20

**BUSINESS CARS:**

- A) WP No. 1 is to be entrained only as follows:
- 1) When occupied — as last car in train (behind caboose), with platform to rear.
  - 2) When deadheaded — on rear of train, immediately ahead of or behind caboose.
- B) Other — As directed by Chief Train Dispatcher.

**SOUTHERN PACIFIC TRAINS**

Locomotive and car speed restrictions which apply to Southern Pacific trains on the Southern Pacific also apply to Southern Pacific trains on the Union Pacific.

**TABLE OF WEIGHT LIMITATIONS**

BETWEEN	AND	GROSS WEIGHT (Car & Contents)
WESTERN DISTRICT (All tracks)		263,000
Except Following:		
San Jose.....	San Jose Freight Depot.....	220,000
Loyalton Branch.....		220,000
Warner Branch.....		220,000
Rough and Ready Island Bridge.....	.5MPH	
(Port of Stockton)	Max. with.....	263,000
	15 MPH	
	Max. with.....	251,000
SACRAMENTO NORTHERN		263,000
Except Following:		
Sacramento.....	Oxford.....	220,000
Cannon.....	Montezuma.....	220,000
Cannon.....	Lib. Farm.....	220,000
Cannon.....	Vacaville.....	220,000
Colusa Jct.....	Sutter.....	220,000
Sutter.....	Tarke.....	169,000
TIDEWATER SOUTHERN		263,000

Note: Greater weights may be handled by authority of General Superintendent Transportation.

**LOCOMOTIVE SPECIFICATIONS, SPEED AND HANDLING RESTRICTIONS**

Maximum speeds in miles per hour shown below is subject to further restrictions as shown for each subdivision or branch.

Engine Number	Maximum Speed	Length Between Pulling Faces	Classification	Model	Starting Tractive Effort	Weight of Engine	Horsepower
<b>WP Engines</b>							
601-606	30	44	ES412	SW 9	61,950	247,800	1,200
608	30	44	ES412	NW 2	62,000	248,000	1,200
701-713	65	56	EM415	GP 7	62,950	251,700	1,500
725-732	65	56	EM418	GP 9	61,900	247,600	1,750
1501-1503	65	45	ES415	SW1500	64,700	257,870	1,500
2001-2010	70	56	EM420	GP 20	64,225	256,890	2,000
2251-2265	70	60	GF423	U 23 B	65,557	262,230	2,250
3001-3022	70	56	EF425	GP 35	64,650	258,975	2,500
3051-3069	70	60	GF430	U 30 B	71,500	289,000	3,000
3501-3559	70	59	EF430	GP 40	69,250	278,000	3,000
<b>SN Engines</b>							
607	30	44	ES412	NW 2	62,000	248,000	1,200
711-712	65	56	EM415	GP 7	61,700	246,800	1,500
<b>UP Engines</b>							
1200-1244	65	44	ES412	SW10	62,800	251,200	1,200
2400-2539	70	67	GF630	U 30C	98,250	396,000	3,000
2800-2809	70	65	GF628	U 28C	93,500	373,600	2,800
2810-2959	70	67	GF630	U 30C	97,750	391,060	3,000
3000-3122	70	66	EF630	SD 40	98,250	393,300	3,000
3123-3488	70	71	EF630	SD 40-2	97,500	390,800	3,000
3489-3808	70	71	EF630	SD 40-2	97,500	393,800	3,000
9000-9005	70	60	EF435	GP 40-X	68,750	274,000	3,500

Note: Certain UP locomotive units have unique speed restrictions at specific locations on 5th and 7th subdivisions.

Trains or engines having UP units listed below engine consists, do not exceed 50 MPH while engine is passing over the following locations.

- Between MP 439 and MP 474
- Between MP 845 and MP 857

**UP ENGINES**

- 3409-3416
- 3418-3426
- 3428-3473

Each lead locomotive used for controlling speeds in excess of 20 MPH must have the speed indicator tested by the engineer after departing originating terminal. Special survey-measured speed test sections listed below are to be used for speed indicator verification:

LOCATION	DIRECTION	SURVEYED M.P.
Oakland	East	M.P.17, 18, 19
Milpitas	West	M.P.7, 6, 5
Stockton	East	M.P.101, 102, 103
	West	M.P.81, 80, 79
Sacramento	East	M.P.146, 147, 148
	West	M.P.131, 130, 129
Oroville	East	M.P.210, 211, 212
	West	M.P.200, 199, 198
Bieber	West	M.P.110, 109, 108
Portola	East	M.P.327, 328, 329
	West	M.P.315, 314, 313
Winnemucca	East	M.P.545, 546, 547
	West	M.P.523, 522, 521
Carlin	East	M.P.657, 658, 659
Elko	East	M.P.691, 692, 693
	West	SP M.P.548, 547, 546
Salt Lake City	West	M.P.906, 905, 904

Engineers noting a speed variance will report this variance on Form 2A (FRA Locomotive Daily Inspection Report).

	Maximum MPH
<b>When operating engine from other than the lead unit in direction of movement</b>	
On curves and approaching highway or street crossing at grade ....	20

Where conditions require, speed must be further reduced to insure safety.

Foreign railroad diesel units, when used, will be permitted maximum speeds but will not exceed maximum speed stencilled in cab of each unit.

Trains handling engines dead in train must not exceed the maximum speed for such class engine.

Locomotive consist at head end of trains must not exceed six operative units. Any units in excess of six must be isolated.

Operative dynamic brake on head end of trains must not exceed four 6-axle units, six 4-axle units, or any combination thereof which totals 24 axles.

Diesel engines may be operated through water when its depth does not exceed three inches, measured from top of rail, at a speed not exceeding five miles per hour.

## TRACKS ON WHICH ENGINE MOVEMENTS RESTRICTED

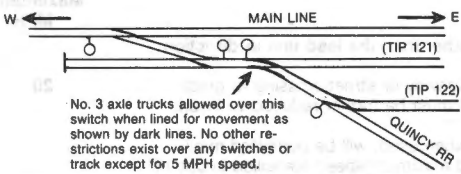
Location and Description of Track	Class of Engine	Prohibited
OAKLAND, Gerber Spur No. 14-783	All except 601 and 1501 class SN607, and UP 1200 class	Entire spur
RADUM	All	Beyond frog on all tracks except 1 and 2
STOCKTON Hunter Street Line	All except 601, 1501, 701 and 725 classes and SN 607, 711, 712 and UP 1200 class	Entire line.
MARYSVILLE Old SN freight connections	All except 601, 1501, 701 and 725 classes and SN 607, 711, 712 and UP 1200 class	Beyond frog.
CRAIG, Outfit spur	All	Beyond restricting sign.
GRAY'S FLAT	THREE axle trucks & all over one unit.	Entire spur.
QUINCY JCT. Stock Track (TIP 071 Off Siding) House Track (TIP 121) and Interchange Track (TIP 122)	3-AXLE TRUCKS  3-AXLE TRUCKS	Entire spur beyond clearance point.  a) 5 MPH on both tracks. b) Second inside switch from west end when lined for Track 122: Do not operate 3-AXLE truck over this switch in this position. There is no such restriction when switch is lined for Track 121. There is no such restriction over other portions of both tracks.
		
JUNGO	All	West of loading ramp No. 1 or 2 spur.
LAKE POINT	All over 4 units	Beyond frog.
TRACY BRANCH, Spur MP 0.5	All	Beyond frog.
RENO BRANCH	3051 & 3501 Class Three Axle Trucks	Between MP 30 and MP 33.
LOYALTON BRANCH	3051, 3501 Class Three Axle Trucks & all over 4 units	Entire Branch
ELLERBECK BRANCH	All over 2 units	Between Flux & Dolomite

**RULE 1203.** Movement of any locomotive or switching of cars over live rails of Track Scales is prohibited except at following locations:  
POZLA (MP 349.1)  
DUNPHY (MP 610.12)

Engines or loads exceeding 55 tons gross weight are restricted on the following spurs to the number of feet shown from clearance point. The spurs listed, except those at Elko, are to be used only for MofW or bad order setouts.

Sand Pass	310
Sano	200
Reynard	200
Phil	500
Trego	200
Cholona	200
Floka	230
Antelope	300
Gaskell	250
Raglan	200
Ellison	150
Kamos	150
Duggan	150
Tonka	150
Elko (Voegler)	300
Elburz	150

Tulaco	150
Sage	600
Silverzone	450
Cliffside	216
Ola	200
Barro	280
Low	580

## TIDEWATER SOUTHERN AND SACRAMENTO NORTHERN

All six axle locomotives and all locomotives weighing in excess of 289,000 lbs. are restricted from use on the Tidewater Southern and Sacramento Northern. All WP locomotives weigh 289,000 lbs. or less and are not restricted for use on Tidewater Southern and Sacramento Northern.

## MAXIMUM HORSEPOWER PER TON RATIOS

Maximum horsepower per ton ratios are listed below. All locomotive(s) not necessary to maintain these ratios must be shut down, if temperature permits, or isolated if temperature does not permit. Refer to Rule 1205 (Item C). Yellow tags will be used by engineers when tags are available. Horsepower ratings for locomotives operating on the Western District are listed in this section.

Trailing locomotives without fuel savers or with inoperative fuel savers should be shut down or isolated first.

FF, OME, OMW, TOF, WPX and WPV ..... 4.0

Subdivision	ALL OTHER TRAINS	
	Eastward	Westward
1	2.0	2.5
2	1.0	1.0
3	2.5	2.5
4*	4.0	3.5
5	2.0	2.5
6	1.5	1.5
7	2.5	2.5

\*Engineers operating with Reserve Engineers on eastward and westward trains can make the necessary adjustments at or near Keddie. Engineers operating without Reserve Engineers on eastward trains enroute to the Fourth Subdivision may leave Oroville with 4.0 HP/ton on line, using fuel savers to the maximum extent possible. Engineers operating without Reserve Engineers on westward trains from the Fourth Subdivision may continue to operate on the Third Subdivision with 3.5 HP/ton reducing to 2.5 HP/ton at the first opportunity.

**Example:** Symbol freight BAF has 53 loads, 26 empties, 5516 trailing tons departing Oroville. Locomotive consist is three GP-40s, totaling 9,000 horsepower. Horsepower per ton ratios are:

1.6 with three units	(9,000 ÷ 5516 = 1.6)
1.1 with two units	(6,000 ÷ 5516 = 1.1)
0.5 with one unit	(3,000 ÷ 5516 = 0.5)

Therefore, only two units are necessary to maintain the maximum allowable horsepower per ton ratio of 1.0 and the other unit must be shut down or isolated.

## WP TOUCHSTONE FUEL SAVER OPERATION

### A. Setup procedure:

- The "unit selector rotary switch" and the "fuel saver toggle switch" are both mounted in a box on the control stand. The "unit selector rotary switch" should be placed in the "LEAD UNIT" position on all locomotives. The "fuel saver toggle switch" should be placed in the "NORMAL OPERATION" position on all locomotives.
- The "fuel saver rotary setup switch" is on the rear wall of the locomotive cab. The switch positions for each equipped locomotive in various locomotive consists are displayed in the body of the table shown below. In the table, #2 and #3 indicate "#2 TRAIL" and "#3 TRAIL" switch positions respectively. The positions shown are recommended as general guidelines. Depending upon conditions, other configurations may be used. If more than six locomotives are in the consist, units seven and above should have their switches placed in "LEAD" and be isolated or shut down.

No. of Units in Consist	1st Loco	2nd Loco	3rd Loco	4th Loco	5th Loco	6th Loco
2	LEAD	#2				
3	LEAD	#2	#3			
4	LEAD	#2	#3	#3		
5	LEAD	LEAD*	#2	#3	#3	
6	LEAD	LEAD*	LEAD*	#2	#3	#3

"When the "fuel saver rotary setup switch" is placed in "LEAD" on a trailing locomotive, the switch is essentially in "off" as this position is not trainlined and will only function on the lead locomotive. If a particular trailing locomotive is not properly operating in fuel saver mode, its "fuel saver rotary setup switch" should be placed in "LEAD." Also, a red "Warning Tag" or other tag should be placed on this switch with the notation "INOPERATIVE FUEL SAVER" and a very brief explanation of the condition. Notify the Train Dispatcher's office and/or the Mechanical Department of this situation.

### B. Operation procedure (all the following instructions refer to operations made on the lead locomotive only):

- When all of the available power is not needed to maintain train speed, the Touchstone fuel saver should be activated by moving the "unit selector rotary switch" to "2nd UNIT" position and then moving the "fuel saver toggle switch" to the "THROTTLE NO. 1 DYN. BK. NORMAL" position. This will reduce to "RUN 1" any trailing locomotive with its "fuel saver rotary setup switch" in "#2 TRAIL."

2. If additional locomotives need to be reduced to "RUN 1," depending upon setup configuration, move the "unit selector rotary switch" to "3rd UNIT" position or "2nd & 3rd UNITS" position. This will reduce power on locomotives with their "fuel saver rotary setup switch" in "#3 TRAIL" or both "#2 TRAIL" and "#3 TRAIL" respectively.
  3. If speed falls below maximum authorized, as many locomotives as needed should be returned to the throttle position of the lead locomotive by reversing the procedure described in items 1 and 2 above.
  4. When the lead locomotive controls are placed in dynamic brake, all locomotives set up to operate in dynamic will function even if their Touchstone fuel savers are activated. Upon returning to power from dynamic brake, all locomotives will again function according to the fuel saver switch positions.
  5. If there are locomotives in the consist that are not equipped with an operable Touchstone fuel saver, these units will not be affected in any way by the use of this equipment.
- 

#### UP POWER SETTER FUEL SAVER OPERATION

- A. Union Pacific locomotives are equipped with the Vapor Power Setter fuel saver. There are two types of this equipment, Power Setter I and Power Setter II. Either device on the lead locomotive will operate the other device on a trailing locomotive. No special setup is required for either device, though some Power Setters are activated by an "on-off" switch located either on the face of the control box or on the control stand.
  - B. Power Setter II operation:
    1. The Power Setter II is mounted on top of the control stand. When all of the available power is not needed to maintain train speed, the Power Setter II should be activated by placing the switch usually marked "Power Setter" in the "up" position (this switch is in the vicinity of the "generator field switch"). This switch may be "up" or "down" on trailing locomotives. On some locomotives this switch may be disconnected or eliminated and the device is activated when the throttle is advanced beyond "IDLE." When the device is activated, a zero will appear in the digital indicator window.
    2. By depressing and releasing the "OFF LINE" or yellow button, the first trailing locomotive equipped with a Power Setter will reduce to "RUN 1" and a "1" will appear in the indicator window. Depressing the "OFF LINE" button a second time will reduce the power of the second trailing locomotive equipped and a "2" will appear in the indicator window. Up to five equipped trailing locomotives can be reduced to "RUN 1."
    3. If speed falls below maximum authorized, as many locomotives as needed should be returned to the throttle position of the lead locomotive by depressing the "ON LINE" or blue button. Each time this button is depressed, one equipped trailing locomotive is returned to the throttle position of the lead locomotive, starting from the last locomotive that was reduced to "RUN 1" and moving forward. The indicator window will show the number of locomotives remaining at reduced power.
    4. When the lead locomotive controls are placed in dynamic brake, all locomotive set up to operate in dynamic will function even if those locomotives have their Power Setter fuel saver devices activated. However, unlike the Touchstone fuel saver, upon returning to power from dynamic brake, the locomotives will *NOT* return to a reduced power condition as all locomotives are reset when going out of power.
    5. If there are locomotives in the consist not equipped with an operable Power Setter, these locomotives will not be affected in any way by the use of this equipment.
  - C. Power Setter I is essentially the same as Power Setter II except:
    1. The control box may be mounted above the front window.
    2. An "on-off" switch may be located on the face of the control box.
    3. The "OFF LINE" and "ON LINE" buttons may be on the face of the control stand.
    4. Light Emitting Diodes numbered zero through five replace the digital indicator window.
-

WESTERN DISTRICT — EASTERN DIVISION

EASTERN

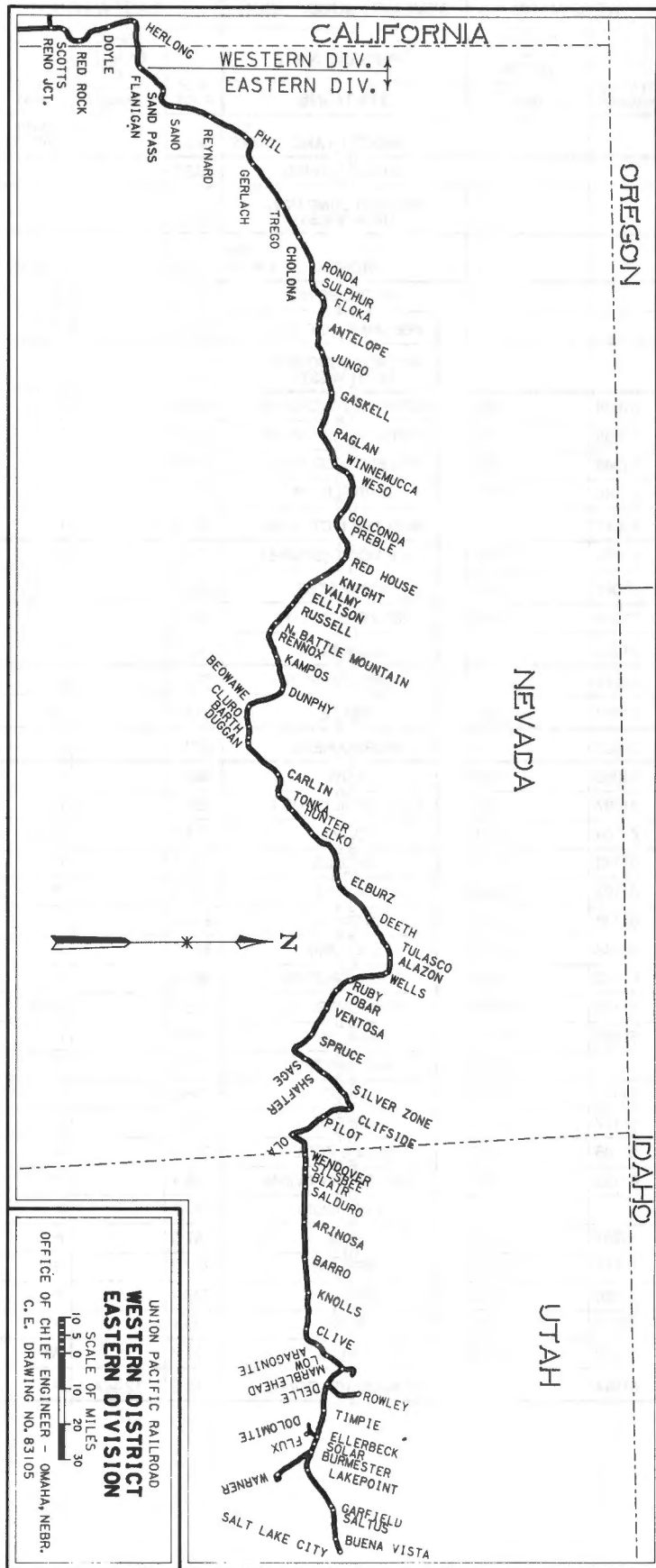

EASTERN DIVISION

WESTWARD		SEVENTH SUBDIVISION	EASTWARD		
STATION NUMBER	LENGTH OF SIDINGS	Timetable No. 7 STATIONS	MILE POST	FIRST CLASS	RULE 6(A)
	FEET			6 Daily	
		NORTH YARD <sup>YD</sup> LMTS	783.6		TO-BK FWYPO
		0.7 GRANT TOWER	782.9		IP
		1.2 WD/SCD JUNCTION (10TH WEST)	781.7		P
		ROPER <sup>YD</sup> LMTS	930.3		KFWYPO
		1.7 UP CROSSING	928.6		AI
		1.4 POLLARD JUNCTION	927.2		IP
		0.5 WD/SCD JUNCTION (10TH WEST)	926.7		P
61034	1080	2.8 BUENA VISTA (SPUR-W)	923.9		P
61035	480	1.8 TERMINAL (SPUR-W)	922.1		P
61045	6050	8.9 GARFIELD (SCD CONN)	913.2		P
61046	3397	1.8 GARFIELD PIT	911.7		P
61047		0.3 SMELTER (JCT. SCD)	911.4		P
61052	5030	5.1 LAKE POINT (SPUR-E)	906.3		P
61061	6168	9.2 BURMESTER	897.1		WYP
61064	2246	3.7 SOLAR (SPUR-W)	893.4		P
61065		0.5 ELLERBECK	892.9		P
61072	3500	7.2 TIMPIE (SPUR-W)	885.7		P
61079	8080	7.1 DELLE	878.6		YP
61087	1737	7.8 MARBLEHEAD	870.8		P
61092	6146	4.7 LOW	866.1		P
61097	440	4.6 ARAGONITE (SPUR-E)	861.5		P
61104	6161	7.3 CLIVE	854.2		P
61113	6150	8.9 KNOLLS	845.3		P
61123	6160	10.4 BARRO	834.9		P
61133	6143	9.8 ARINOSA	825.1		P
61143	6143	9.6 SALDURO	815.5		P
61149	4070	6.8 BLAIR (SPUR-W)	808.7		P
61151	10200	2.1 WENDOVER, UT.	806.6		WYP
61160	6143	8.0 OLA, NV.	798.6		P
	1800	2.9 DYKE (SPUR-W)	795.7		P
61169	6152	6.8 PILOT	788.9		P
61177	6143	7.8 CLIFSIDE	781.1		P
61186	6160	8.7 SILVER ZONE	772.4		P
61192	6198	6.0 SHAFTER (NN CONN)	766.4		P
		0.6 NN CROSSING	765.8		I
61201	6183	8.3 SAGE	757.5		P
61211	6153	10.3 SPRUCE	747.2		PY
61220	6160	9.0 VENTOSA	738.2		P
61230	6123	10.1 RUBY	728.1		P
61240	6198	10.4 WELLS	717.7		WP
61244		4.1 ALAZON (SP CONN)	713.6	12.44AM	P

EASTERN DIVISION

WESTWARD		SEVENTH SUBDIVISION CONT'D.	EASTWARD		
STATION NUMBER	LENGTH OF SIDINGS	Timetable No. 7 STATIONS	MILE POST	FIRST CLASS	RULE 6(A)
	FEET			6 Daily	
61244		ALAZON (SP CONN)	713.6	12.44AM	P
61249	1026	4.8 TULASCO (SPUR-E)	708.8		P
61257		7.8 SP CONN.	701.0		P
61258	5769	1.0 DEETH	700.0	12.30	P
61275	5844	16.7 ELBURZ	683.3	12.15AM	P
	2100	0.2 SP CONN	683.1		P
	800	9.5 PARDO (SPUR-E)	673.6		OP
		2.9 PROJECT TRACK (SPUR-E)	670.7		P
61293	YARD	5.3 ELKO (SP CONN) <sup>YD</sup> LMTS	665.4	≤11.59PM	TO-R-B KFWYPO
		(263.2)			

Automatic Block Signal System extends from Elko to Alazon, Eastward only.

Traffic Control System in effect Eastward Interlocking Home Signal, Pollard Jct., MP 927.2 to Alazon. See Rule 540.

Current UP-WP Joint Pamphlet is Union Pacific-Western Pacific Joint Pamphlet No. 2 (effective October 15, 1972) as amended by Joint Bulletin No. 1 dated July 24, 1980. This Joint Bulletin is posted at North Yard, Roper and Elko; be governed by Rule 4-C.

See SPECIAL INSTRUCTIONS — SEVENTH SUBDIVISION, for instructions concerning movement between Pollard Jct. and Roper.

CLEARANCE AND REGISTER REQUIREMENTS AND TRAIN MOVEMENT INSTRUCTIONS

**Rule T-82-A.** A clearance authorizing an eastward SP first-class train at Sparks for movement over the UP at Weso will apply only to Carlin, where another clearance must be obtained authorizing train Carlin to Alazon.

**Rules T-82-A and T-83** will not apply to SP trains at Elko, but they will be governed by train-order signal.

**Rule T-86.** Eastward inferior trains may run ahead of eastward superior trains Elko to Alazon Eastward superior trains must run expecting to find inferior trains running ahead.

**Rules T-83-A, T-83-B. Elko.** Eastward SP first-class trains register by ticket. Other eastward SP trains will not register.

**Rule T-83-B.** When an eastward schedule or section is checked on register at Carlin, or visual identification is made between Carlin and Elko, such identification or register check may be applied at Elko.

**Rule T-97.** Eastward extras between Elko and Alazon may be authorized by clearance as follows:

Eastward SP extras may be authorized by clearance issued at Carlin which will confer authority to run extra Carlin to Alazon.

Eastward UP extras may be authorized by clearance at Elko which will confer authority to run extra Elko to Alazon.

Other eastward extra movements may be authorized verbally by train dispatcher.

When necessary to annul the authority of an extra which has been authorized by clearance or verbally, a train order will be issued in the following form:

"Eng . . . . . is annulled as an extra from . . . . ."

**Rule 204.** Train orders may be issued to eastward SP trains on Sixth Subdivision which will affect their movement on the Seventh Subdivision between Elko and Alazon.

**Rule 221.** Applies only to eastward SP trains at Elko.

**Rule 204.** Train orders may be issued at North Yard and Elko which cover speed restrictions and track conditions on South Central District portion of track between Smelter and North Yard, and DRGW portion of track between Roper and 10th West.

**Salt Lake City — Rule T-82-A.** All trains departing Roper or North Yard which may operate via South Central District North Yard to Smelter must, in addition to Western District Clearance, receive a South Central Clearance at North Yard together with any orders in effect between 10th West and Smelter. Any trains which will operate via SP Alazon to Elko in addition to Western District Clearance must receive SP Clearance at North Yard together with any orders in effect between Alazon and Elko.

**Elko Rule T-82-A.** Eastward trains which may operate via UP Smelter to 10th West must, in addition to Western District clearance, receive a UP clearance at Elko together with any orders in effect between Smelter and 10th West.

## EASTERN DIVISION

### SPEED RESTRICTIONS — SEVENTH SUBDIVISION

LOCATION	MPH	LOCATION	MPH
Maximum Speed between MP 926.5 and MP 666.4	60	Shafter Over NN Crossing MP 765.78	50
Between Roper and Pollard Jct.	15	Sage 755.2 and 753.0	40
Pollard Jct. and MP 926.5	20	Alazon Using Crossover MP 713.57, Alazon	25
Smelter When using No. 20 turnouts at Smelter	35	Elburz 681.0 and 674.8	55
Between Mileposts Delle 868.8 and 864.3	50	Elko 666.4 and 665.4 (See Note)	15
Wendover 800.0 and 799.5	35		
799.5 and 784.5	45		
Pilot 784.5 and 775.3	25		

NOTE: When engine on eastward train on main track passes the limits of the 15 MPH restriction at MP 666.4, speed may be increased to 30 MPH until rear of train has passed MP 666.4

Trains or engines trailing through spring switch old main track to main track East Elko must not exceed 5 MPH until engine is on 12th St. Crossing then 20 MPH through switch.

NOTE: See Speed and Car Handling Restrictions section for list of UP units restricted to 50 MPH between MP 857 and MP 845.

Other Maximum Speeds	MPH
Westward Trains over Dual Control Switch at MP 670.7	20
Through turnouts with power-operated switches in reverse position. Pollard Jct. to West switch Wells, inclusive and through sidings at the stations listed	20
Shafter, NN Yard. Straight track 10 MPH, curves 5 MPH.	

### PASSENGER TRAINS

#### Seventh Subdivision

Between:		
MP 664.4 and MP 666.4 Elko Yard	Yard Speed	
After engine passes MP 666.4 speed may be increased to 35 MPH.		
MP 666.4 and MP 674.7	70	
MP 674.7 and MP 681.0	55	Note 1
MP 681.0 and Alazon	70	
Using crossover Alazon	25	

#### WESTWARD MOVEMENT ON UP TRACK, ALAZON TO ELKO

When moving westward on UP track between Alazon and Weso, maximum speed of passenger trains and light engines is 59 MPH, and for freight and mixed trains 49 MPH, but all other speed restrictions must be observed. Unless proceed signal received or it is known that warning devices are operating, such trains and engines must stop approaching road crossings where automatic warning devices are installed, and may proceed after member of crew protects crossing. In addition to street crossings within Elko city limits the following road crossings are protected by automatic warning devices.

Highway 11	MP 687.37
Deeth-Star Valley Road	MP 699.20

Do not exceed 20 MPH westward over dual control switch at MP 670.7 on UP Track.

Refer to section on Elko in SPECIAL INSTRUCTIONS — for instructions concerning westbound movements on UP track at Elko.

## EASTERN DIVISION

WESTWARD		SIXTH SUBDIVISION	EASTWARD			
STATION NUMBER	LENGTH OF SIDINGS	Timetable No. 7	MILE POST	FIRST CLASS	RULE 6(A)	
	FEET	STATION		6 Daily		
61293	YARD	ABS EASTWARD ONLY TCS	665.4	11.58PM	TO-R-B KFWYP	
61302	6065		ELKO (SP CONN) LMTS 8.4	665.4		
61309	1248		HUNTER (SPUR-E) 6.9	657.0		P
			TONKA (SPUR-E) 4.1	650.1		P
61312			EAST CARLIN (SP CONN) 1.4	646.0		P
61314	1296		CARLIN 1.2	644.6	11.34PM s11.29PM	R-BWP
61315			WEST CARLIN (SP CONN) 11.6	643.4		I
61326	1018		DUGGAN (SPUR-E) 1.3	631.8		P
61327			BARTH (SP CONN) 3.4	630.5	11.13	P
61331	5335		CLURO (SPUR-E) 7.6	627.1		P
61339	5999		BEOWAWE 9.4	619.5	11.02	TO-P
61348	5340		DUNPHY (SPUR-E) 8.8	610.1		OP
61357	5143		KAMPOS (SPUR-E) 10.0	601.3		P
61367	5860		RENNOX (SPUR-E) 8.8	591.3		P
61376	341		RUSSELL (SPUR-E) 7.1	582.5		P
61383	6268	ELLISON 3.2	575.4	10.25	P	
61386	4.95 MILES TO SP, 9733 FT TO END OF SPUR IN PLANT	VALMY (SPUR-E) (SP CONN) 2.1	572.2		P	
61388	316	KNIGHT (SPUR-E) 7.1	570.1		P	
61395	5375	RED HOUSE (SPUR-E) 14.6	563.0		P	
61409	5020	GOLCONDA (SPUR-E) 12.4	548.4		P	
61422		WESO (SP CONN) 3.7	536.0	9.51PM	P	
61426	N10,000 S 5,150	WINNEMUCCA (133.1)	532.3		BKWYP	

Traffic Control System in effect Weso to Winnemucca. See Rule 540.  
Automatic Block Signal System extends from Weso to Elko, Eastward only.  
**Rules 105 and 340-A.** North siding Winnemucca is a controlled siding.

### CLEARANCE AND REGISTER REQUIREMENTS AND TRAIN MOVEMENT INSTRUCTIONS

**Winnemucca. Rule T-82-A.** No clearance is required at UP Winnemucca for movement to Fifth or Sixth Subdivisions.

UP outbound crew members will contact train dispatcher prior to arrival of their train and train dispatcher will advise the order numbers or other instructions the train received prior to arrival Winnemucca. Train dispatcher will issue any further instructions and will give verbal authority to depart Winnemucca. Crew members will check the order numbers and messages against orders and instructions on the train.

Train orders or other written instructions regarding track conditions, underfoot conditions load dimensions, train movement, work to be performed, or other instructions concerning Fifth and Sixth Subdivisions will be issued to Westward UP Trains at Elko and Carlin and to Eastward UP Trains at Portola. At Winnemucca, inbound engineer leave such information on locomotive and inbound conductor leave such information in desk drawer of caboose. Clearance issued at Elko to Westward Trains will list orders in effect on Fifth Subdivision and between Weso and Winnemucca and additional clearance issued at Portola to Eastward Trains will list orders in effect on Sixth Subdivision.

**Valmy. Rules T-82-A, T-86.** Trains operating via SP Elko to Valmy, thence UP, Valmy to Elko will not require clearance at Valmy. UP clearance and applicable train orders covering eastward trip Valmy to Elko will be received by UP trains at Elko. Prior to leaving Valmy, crew member must contact train dispatcher for any further instructions. Trains finding leaving signal at Valmy displaying proceed indication may run ahead of any eastward superior trains.

**Elko. Rule T-82-A.** Westward UP trains require a UP clearance in addition to an SP clearance. Train orders to be received at Elko will cover Weso to Winnemucca and Fifth Subdivision, when applicable.

**Rule T-82-A.** SP trains which are to operate east of Weso on UP must, unless otherwise instructed, receive UP clearance at Sparks, Lovelock, Wendel or SP Winnemucca. Clearance at UP Winnemucca is not required.

A clearance authorizing an eastward SP first-class train at Sparks for movement over the UP at Weso will apply only to Carlin, where another clearance must be obtained authorizing train Carlin to Alazon.

**Rule T-86.** Eastward SP inferior trains arriving Weso may run ahead of superior trains Weso to Carlin when T.C.S. signal at Weso displays PROCEED indication. Under the same conditions, eastward inferior UP trains may run ahead of superior trains Weso to Alazon. Eastward inferior SP trains receiving proceed signal at East Carlin may run ahead of eastward superior trains Carlin to Alazon. Eastward superior trains must run expecting to find inferior trains running ahead under these conditions.

**Carlin. Rule T-83-A.** Register station for eastward first-class trains only. Registration will be by ticket and SP operator will enter same on joint register SP station Carlin.

**Elko. Rule T-83-A.** Eastward SP first-class trains register by ticket. Other eastward SP trains will not register.

**Rule T-83-B.** When an eastward schedule or section is checked on register at Sparks, or visual identification is made between Sparks and Weso, such identification or register check may be applied at Weso.

When an eastward schedule or section is checked on register at Carlin, or visual identification is made between Carlin and Elko, such identification or register check may be applied at Elko.

**Rule T-83-B.** Second paragraph will not apply at Carlin to work extras and westward extras. Such trains must not leave Carlin until it has been ascertained whether all regular trains due have arrived or left.

**Rule T-97.** Eastward extras between Weso and Alazon may be authorized by clearance as follows:

Eastward SP extras may be authorized by clearance issued at Sparks, Lovelock or Wendel which will confer authority to run extra Weso to Carlin.

Eastward SP extras may be authorized by clearance issued at Carlin which will confer authority to run extra Carlin to Alazon.

Eastward UP extras may be authorized by clearance issued at Portola which will confer authority to run extra Weso to Elko.

Eastward UP extras may be authorized by clearance at Elko which will confer authority to run extra Elko to Alazon.

Other eastward extra movements may be authorized verbally by train dispatcher. Such oral authorization will confer authority to run extra to Elko unless otherwise specified.

When necessary to annul the authority of an extra which has been authorized, either verbally or by clearance, a train order will be issued in the following form:

"Eng . . . . . is annulled as an extra from . . . . ."

**Rule 204.** Train orders may be issued to eastward SP trains at Sparks, Lovelock and Wendel which will affect their movement between Weso and Carlin.

Train orders may be issued to eastward SP trains on Sixth Subdivision which will affect their movement on the Seventh Subdivision between Elko and Alazon.

Train orders may be issued to westward SP and UP trains at SP Carlin and Westward UP trains at Elko which will affect their movement on UP between Weso and Flanigan and Weso and Portola.

Train orders may be issued to eastward UP trains at Portola which will affect their movement between Weso and Elko.

**Rule 540. Weso.** Westward trains may leave Weso without contacting the train dispatcher when westward signal indicates PROCEED and will retain their identity.

### EASTERN DIVISION SPEED RESTRICTIONS — SIXTH SUBDIVISION

LOCATION	MPH	LOCATION	MPH
Maximum Speed Between MP 665.4 and MP 532.3	60	East Carlin and West Carlin Using Turnouts, East and West Carlin	50 15
Between Mile Posts Elko 665.4 and 664.4	YARD SPEED	West Carlin 637.7 and 628.3	45
Hunter 650.8 and 650.4	50	Weso 536.0 and 532.3 Using Turnouts, Weso	55 25
<b>Other Maximum Speeds</b>			<b>MPH</b>
Westward Trains over Dual Control Switches at East Carlin Detour and Valmy			20
Through turnouts with power-operated switches in reverse position at Valmy and East end North Siding Winnemucca and through Sierra Pacific track Valmy which extends between UP and SP main tracks and through North Siding Winnemucca.			20
Movements on all industry tracks at Valmy are to be made at yard speed.			

**PASSENGER TRAINS**

**EASTERN**

<b>Sixth Subdivision</b>		
Using Turnouts Weso .....	<b>25</b>	
Between:		
MP 536.0 and MP 628.3 .....	<b>70</b>	Note 1
MP 628.3 and MP 637.7 .....	<b>45</b>	
MP 637.7 and MP 638.3 .....	<b>60</b>	Note 2
MP 638.3 and West Carlin .....	<b>70</b>	
West Carlin and East Carlin .....	<b>50</b>	
Using Turnouts, West and East Carlin .....	<b>15</b>	
East Carlin and MP 650.4 .....	<b>60</b>	Note 3
MP 650.4 and MP 650.8 .....	<b>50</b>	
MP 650.8 and MP 652.5 .....	<b>60</b>	Note 3
MP 652.5 and MP 664.4 .....	<b>70</b>	
MP 664.4 and MP 665.4 Elko Yard .....	<b>Yard Speed</b>	

**WESTWARD MOVEMENT ON UP TRACK ELKO TO WESO**

When moving westward on UP track between Elko and Weso, maximum speed of passenger trains and light engines is 59 MPH, and for freight and mixed trains 49 MPH, but all other speed restrictions must be observed. Unless proceed signal received or it is known that warning devices are operating, such trains and engines must stop approaching road crossings where automatic warning devices are installed, and may proceed after member of crew protects crossing. In addition to street crossings within Elko city limits the following road crossings are protected by automatic warning devices.

Eden Valley Road .....	MP 548.02
Preble Road .....	MP 553.60
Highway 21 .....	MP 618.59
Highway 51 .....	MP 642.61

Do not exceed 20 MPH westward over dual control switches at East Carlin Detour and Valmy on UP track.

Refer to sections on Elko, West Carlin and Valmy for instructions concerning westbound movements on UP track at those points.

**EASTERN**

# EASTERN/WESTERN DIVISIONS

WESTWARD		FIFTH SUBDIVISION	EASTWARD	
STATION NUMBER	LENGTH OF SIDINGS	Timetable No. 7	MILE POST	RULE 6(A)
	FEET	STATIONS		
61426	N10,000 S 5,150	<b>WINNEMUCCA</b>	532.3	BKWYP
		13.1		
61440	6145	RAGLAN	519.2	P
		10.6		
61450	6148	GASKELL	508.6	P
		12.0		
61461	6163	JUNGO	496.6	P
		9.0		
61471	6156	ANTELOPE	487.6	P
		8.2		
61479	6167	FLOKA	479.4	P
		8.8		
61488	6158	RONDA	470.6	P
		9.3		
61497	6150	CHOLONA	461.3	P
		10.1		
61507	6145	TREGO	451.2	P
		13.3		
61520	6289	GERLACH	437.9	WYP
		7.1		
61528	6160	PHIL	430.8	P
		14.5		
61542	5647	REYNARD	416.3	P
		11.6		
61554	6152	SANO	404.7	P
		11.0		
61565	6162	SAND PASS	393.7	P
		9.3		
		<b>SP CONNECTION</b>	384.4	P
		0.9		
61574	6162	FLANIGAN, NEV.	383.5	P
		11.8		
61587	4193	HERLONG, CAL.	371.7	P
		9.1		
61596	6369	DOYLE	362.6	WP
		10.4		
		RED ROCK	352.2	P
		3.1		
61610	1670	POZLA	349.1	P
		3.5		
61613	6126	SCOTTS	345.6	P
		3.8		
61616	3000	<b>RENO JUNCTION</b>	341.8	PY
		2.7		
61619	6245	CHILCOOT	339.1	P
		11.6		
61631	5770	HAWLEY	327.5	P
		6.1		
61637	10771	PORTOLA	321.4	TO-BK FWYP
		(210.9)		

Traffic Control System in effect Winnemucca to Portola inclusive. See Rule 540.

Division Point between Eastern and Western Divisions is MP 384.38.

Rules 105 and 340-A. North siding Winnemucca is a controlled siding.

### CLEARANCE AND REGISTER REQUIREMENTS AND TRAIN MOVEMENT INSTRUCTIONS

#### SP Trains

**Wendel. Rules T-82 and 204.** SP trains will be authorized by clearance at Wendel which will be authority for movement on UP track Flanigan to Carlin. Train orders may be issued at Wendel which will affect movement Flanigan to Carlin.

**Carlin. Rule 204.** Train orders may be issued to westward SP trains at SP Carlin which will affect their movement between Weso and Flanigan.

**Winnemucca. Rule T-82-A.** Clearance not required.

# SPEED RESTRICTIONS — FIFTH SUBDIVISION

LOCATION	MPH		MPH
Maximum Speed Between MP 532.3 and MP 321.4	60	SANO 404.7 and 397.8 397.8 and 390.7	50 35
Between Mileposts Winnemucca 527.0 and 508.5	50	SP CONN. FLANIGAN MP 384.3 Using Turnout	20
JUNGO 495.6 and 494.9 494.9 and 494.5 494.5 and 489.9 489.9 and 488.3	55 45 35 50	DOYLE 356.0 and 340.3	40
		HAWLEY 324.8 and 321.4	40
<b>Other Maximum Speeds</b>			<b>MPH</b>

Through turnouts with power-operated switches in reverse position  
North Siding Winnemucca and Raglan to Portola inclusive and through  
the sidings at these stations ..... **20**  
EXCEPTION — Reno Jct. .... **10**

NOTE: See Speed and Car Handling Restrictions section for list of UP units restricted to 50 MPH between MP 474 and MP 439.

### EASTERN DIVISION BRANCHES

WESTWARD		WARNER BRANCH	EASTWARD	
STATION NUMBER	LENGTH OF SIDINGS	Timetable No. 7		
	FEET	STATIONS		
61061	6168	BURMESTER	0.0	WYP
60007	1255	MARSHALL 7.0	7.0	
60013	1254	CONN. TOOELE ARMY DEPOT 6.5	13.5	
60015		WARNER 2.0	15.5	
		(15.5)		

WESTWARD		ELLERBECK BRANCH	EASTWARD	
STATION NUMBER	LENGTH OF SIDINGS	Timetable No. 7		
	FEET	STATIONS		
61065		ELLERBECK 2.7	0.0	P
60103		WYE 1.0	2.7	Y
60104	1965	FLUX 2.0	3.7	
60105	134	DOLOMITE	4.7	
		(5.7)		

NOTE: Main track to Flux and main track to Dolomite diverge at Wye.

WESTWARD		ROWLEY BRANCH	EASTWARD	
STATION NUMBER	LENGTH OF SIDINGS	Timetable No. 7		
	FEET	STATIONS		
61079	8080	DELLE 10.6	0.0	YP
60211	3380	ROWLEY 0.6	10.6	
		END OF BRANCH	11.2	
		(11.2)		

WESTWARD		MARBLEHEAD BRANCH	EASTWARD	
STATION NUMBER	LENGTH OF SIDINGS	Timetable No. 7		
	FEET	STATIONS		
61087	1738	MARBLEHEAD 4.66	0.0	P
60305	1230	MARBLEHEAD PLANT 0.21	4.66	
		END OF BRANCH	4.87	
		(4.87)		

#### TRAIN MOVEMENT INSTRUCTIONS

**Rule 201.** Train order authority is not required on Warner, Ellerbeck, Rowley and Marblehead Branches and all movements on branches must be made at yard speed.

**Rule 340-A.** Trains arriving Burmester from Warner Branch and Delle from Rowley Branch are governed by Rule 340-A.

#### SPEED RESTRICTIONS

LOCATION	MPH	LOCATION	MPH
Warner Branch Maximum Speed	20	Rowley Branch Maximum Speed	20
Ellerbeck Branch Maximum Speed	20	Marblehead Branch Maximum Speed	10



**WESTERN DIVISION**

STATION NUMBER	LENGTH OF SIDINGS FEET	WESTWARD				FOURTH SUBDIVISION	
		SECOND CLASS				Timetable No. 7	
		11 Daily	9 Daily	7 Daily	5 Daily	STATIONS	
62112	YD LMTS	6.00PM	12.01PM	6.00AM	12.01AM	BIEBER	
62096	387					16.4 LITTLE VALLEY LUMBER CO. (SPUR-W)	
62095	4251	6.40PM	12.40PM	6.40AM	12.40AM	0.6 LITTLE VALLEY	
62090	448					5.0 WILLOW SPRINGS (SPUR-W)	
62076	6756	7.30PM	1.30PM	7.30AM	1.30AM	13.3 HALLS FLAT	
62063	4235	7.50PM	1.50PM	7.50AM	1.50AM	13.6 LODGEPOLE	
62044	7245	8.15PM	2.15PM	8.15AM	2.15AM	19.1 ROBBERS CREEK	
62039	4388					4.4 WESTWOOD	
62035						4.2 CLEAR CREEK JCT.	
62026	7942					9.5 ALMANOR	
62015	4236					11.0 GREENVILLE	
62009	620					6.1 CRESCENT MILLS	
62006	4208					2.4 MOCCASIN	
62003	781					3.1 INDIAN CREEK (SPUR-W)	
61677						3.1 KEDDIE	
						(111.8)	

**Rule 540.** Traffic Control System in effect MP 55.8 to Keddie. Westward signal located MP 57.5 is Distant Signal for Absolute Signal at MP 55.8.

**Rules 105 and 340-A.** Sidings Almanor and Robbers Creek are Controlled Sidings.

**Rule 301.** Signal governing eastward movement from siding at east end of Robbers Creek is located on left side of track.

**Rule 288.** Eastward signal at MP 55.8 marks the east end of TCS and may display signal aspect per Rule 292 or Rule 288. Signal may be passed at authorized speed when aspect per Rule 288 is displayed provided necessary train order authority has been received. Rule 509 applies.

**CLEARANCE AND REGISTER REQUIREMENTS  
AND TRAIN MOVEMENT INSTRUCTIONS**

**Rule T-82-A.** Westward trains do not require clearance or train order authority to operate in TCS territory west of Robbers Creek and will be identified as "Extras West."

**Rules T-82-A and 204.** Train orders will be issued at Oroville Yard and Portola which affect movement on Fourth Subdivision. Train orders will be issued at Bieber which affect movement on Third Subdivision. Clearance is not required at Keddie. TCS Signals will govern movements between MP 55.8 and Oroville Yard or Portola. Eastward Trains will check with Fourth Sub Dispatcher and Westward Trains with Third Sub Dispatcher to determine they have all applicable Form "Z" orders before leaving Keddie.

**Rules T-83-A and T-83-B Robbers Creek.** Westward Trains will report arrival Robbers Creek to Fourth Sub Dispatcher when engine passes east switch. Refer to Rule 40. Radio Communication will be utilized when available. If not available, telephone communication will be used.

**Rule T-97.** Eastward Trains must not pass absolute signal at East Robbers Creek unless train order authority to do so including train order form "G" or "H" has been received unless movement is not to go beyond MP 55.8.

**WESTERN DIVISION**

FOURTH SUBDIVISION		EASTWARD	
Timetable No. 7		MILE POST	RULE 8(A)
STATIONS			
BIEBER		111.8	TO-R-BKWYP
16.4 LITTLE VALLEY LUMBER CO. (SPUR-W)		95.4	P
0.6 LITTLE VALLEY		94.8	WP
5.0 WILLOW SPRINGS (SPUR-W)		89.8	P
13.3 HALLS FLAT		76.5	YP
13.6 LODGEPOLE		62.9	P
19.1 ROBBERS CREEK		43.8	P
4.4 WESTWOOD		39.4	P
4.2 CLEAR CREEK JCT.		35.2	P
9.5 ALMANOR		25.7	YP
11.0 GREENVILLE		14.7	WP
6.1 CRESCENT MILLS		8.6	P
2.4 MOCCASIN		6.2	P
3.1 INDIAN CREEK (SPUR-W)		3.1	P
3.1 KEDDIE		0.0	FWYP
(111.8)			

**WESTERN DIVISION**

**SPEED RESTRICTIONS — FOURTH SUBDIVISION**

LOCATION	MPH	LOCATION	MPH
Bieber		Westwood	
Main Track	Yard Speed	37.3 and 34.55	30
Other than main track	10		
Maximum Speed Between		Clear Creek Jct.	
MP 111.81 and MP 0.0	45	34.55 and 16.0	25
Between Mileposts		Almanor	
Bieber		16.0 and West Switch	
111.81 and 106.53	30	Greenville	35
106.53 and 98.1	25	Greenville	
98.1 and 93.4	30	West switch Greenville	
		and 6.19	40
Little Valley		Moccasin	
93.4 and 78.71	25	6.19 and 1.95	25
		Indian Creek	
		1.95 and 0.0	10

WESTERN DIVISION

WESTWARD		THIRD SUBDIVISION	EASTWARD	
STATION NUMBER	LENGTH OF SIDINGS	Timetable No. 7	MILE POST	RULE 8(A)
	FEET			
61637	10771	PORTOLA	321.4	TO-BK FWYP
61640	4158	3.1 MABIE (SPUR-W)	318.3	P
61648	4869	7.9 BLAIRSDEN	310.4	P
61656	7892	8.5 SLOAT	301.9	WP
61662	4610	5.5 SPRING GARDEN	296.4	P
61670	3843	8.5 QUINCY JUNCTION	287.9	P
61677	7169	6.4 KEDDIE	281.5	FWYP
61681	4202	4.2 PAXTON	277.3	P
61685	3504	3.4 TWIN	273.9	P
61686	546	1.3 GRAYS FLAT (SPUR-W)	272.6	P
61688	9810	2.1 VIRGILIA	270.5	WP
		6.0 RICH BAR	264.5	P
61698	4573	4.4 BELDEN	260.1	P
61703	6713	4.5 CAMP ROGERS	255.6	P
61706	1982	2.5 TOBIN (SPUR-E)	253.1	P
61711	3683	5.5 MERLIN	247.6	P
		4.1 CRESTA	243.5	P
61719	6091	4.0 PULGA	239.5	WP
61723	6739	4.6 POE	234.9	P
61732	6515	8.9 JAMES	226.0	WP
61738	6385	6.0 ELSEY	220.0	P
61744	6311	6.1 KRAMM	213.9	P
61749	4687	4.8 OROVILLE DEPOT	205.1	P
61751	YARD	2.2 OROVILLE YARD	202.9	TO-BKF TWYPO
		(114.5)		

TCS Traffic Control System in effect Portola to Oroville Yard inclusive. See Rule 540.

Equation MP 205.47 equals MP 209.51, which are identical points. Equation is a result of Oroville line change being 4.04 miles shorter than original route.

Rules 105 and 340-A. Sidings Oroville Depot to Blairsden inclusive except Twain are controlled sidings.

Rules T-82 and 204. Train orders will be issued at Oroville Yard and Portola which affect movement on Fourth Subdivision. Train orders will be issued at Bieber which affect movement on Third Subdivision. Clearance is not required at Keddie.

WESTERN DIVISION

SPEED RESTRICTIONS — THIRD SUBDIVISION

LOCATION	MPH	LOCATION	MPH
Maximum Speed Between MP 321.4 and MP 202.9	45	Poe 227.3 and 224.25	35
Between Mileposts Portola 321.4 and 300.0	30	Eley 215.6 and 215.4	35
Sloat 300.4 and 232.2 West Wye Switch Keddie, Diverging Route Grays Flat Spur	25 10 5	Kramm 205.47 and 202.9	45
Other Maximum Speeds			MPH
Through turnouts with power-operated switches in reverse position, as follows: Portola, James, Eley, East switch Oroville depot siding and through the sidings at the stations listed.....			20

**WESTERN DIVISION**

WESTWARD		SECOND SUBDIVISION	EASTWARD	
STATION NUMBER	LENGTH OF SIDINGS	Timetable No. 7	MILE POST	RULE 6(A)
	FEET			
61751	YARD	OROVILLE YARD	202.9	TO-BKF TWYPO
61752	510	PERMANEEER (SPUR-E)	201.2	P
61761	6155	CRAIG	193.0	P
		TAMBO	185.6	P
		SP CONNECTION	180.4	P
61774		BINNEY JUNCTION (SP CROSSING)	180.2	IP
61776	5055	MARYSVILLE (SN CONN.)	178.8	P
61779		CLEVELAND (SN CONN.)	175.6	P
61782	7290	MOUNKES	172.9	P
		TROWBRIDGE	162.0	P
61798	6242	PLEASANT GROVE	156.5	P
61802		SANKEY (SN CONN)	152.5	P
61807	510	BOMBAY (SPUR-E)	146.6	P
61811	6247	DEL PASO	143.6	P
61814		GLOBE	140.7	P
61815		HAGGIN (SN & SP CONNS.)	139.5	P
61816		"R" STREET (SP CROSSING)	138.0	IYP
61818	YARD	SOUTH SACRAMENTO	136.0	BKF WPO
61821	717	KENWOOD (SPUR-E)	133.2	P
61822	4874	POLLOCK	132.4	P
61823	1400	LAGUNA CREEK (SPUR-E)	129.8	P
61832	6250	PHILLIPS	121.9	P
61840	3638	THORNTON	113.9	P
61845	641	VILLINGER (SPUR-W)	107.8	P
61848	1200 3360	TERMINOUS JCT. (SPURS-W)	105.3	P
61849	897	KINGDON	104.7	P
61856	5895	HAMMER LANE	97.9	P
61858		NORTH CHANNEL	96.2	P
61859		EL PINAL (SP CROSSING)	95.1	IP
61860	YARD	FLORA STREET	94.3	P
61860		WEBER AVENUE (SP CROSSING)	93.8	IP
		ATSF CROSSING	93.2	IP
61862	YARD	STOCKTON YARD	92.0	TO-BKF TWYPO
		(110.9)		

**Rule 14-A.** At South Sacramento and Sacramento, engine whistle or horn should be used only when necessary and then kept as soft as possible consistent with the particular requirement.

Traffic Control System in effect Oroville Yard to Stockton Yard inclusive. See Rule 540.

**WESTERN DIVISION**

**SPEED RESTRICTIONS — SECOND SUBDIVISION**

LOCATION	MPH	LOCATION	MPH
Maximum Speed Between MP 202.9 and MP 92	60	Del Paso 141.8 and 139.2 "C" St. Sacramento	35
Between Mileposts Oroville Yard 202.9 and 201.9	45	Haggin 139.2 and 135.2	20
201.9 and 201.7 on curve	40	South Sacramento 135.2 and 129.0	40
201.7 and 181.1	50	Hammer Lane 97.3 and 95.2	50
Tambo 181.1 and 177.5	30	North Channel 95.2 and 92.0	20
Marysville 177.5 and 141.8	50		
<b>Other Maximum Speeds</b>			<b>MPH</b>
Through turnouts with power-operated switches in reverse position, as follows:			
Craig, Mounkes, Pleasant Grove, Del Paso and Phillips and through the sidings at the stations listed.....			20

WESTERN DIVISION

WESTWARD		FIRST SUBDIVISION	EASTWARD	
STATION NUMBER	LENGTH OF SIDINGS	Timetable No. 7 STATIONS	MILE POST	RULE 6(A)
	FEET			
61862	YARD	STOCKTON YARD	92.0	TO-BKF TWYPO
61867	1557	3.6 FRENCH CAMP	88.4	P
61870	6241	2.6 LATHROP	85.8	P
61871		1.3 SP CROSSING (LATHROP)	84.5	IP
61872	5555	2.4 WYCHE	82.1	P
61878	759	6.5 COCHRAN	75.6	P
		1.5 SP CROSSING (LYOTH)	74.1	AIP
61880		0.3 LYOTH (SPUR-W, SEE NOTE)	73.8	P
		1.0 TRACY	72.8	YP
61881	10692	1.9 AYALA (SPUR-E)	70.9	P
61882	5700	7.6 MIDWAY	63.3	P
61891	5518	7.1 ALTAMONT	56.2	P
61898	5560	5.9 LOX (SPUR-W)	50.3	P
61904	1850	1.1 TREVARNÓ (SPUR-W)	49.2	P
61905	6434	2.2 LIVERMORE	47.0	P
61907	4117	3.6 RADUM	43.4	P
61911	1758	0.4 SP CROSSING	43.0	AI
		0.3 SP CROSSING	42.7	AIP
		1.0 PLEASANTON (SPUR-W)	41.7	P
61912	500	3.6 HEARST	38.1	P
61916	4423	7.6 NILES JUNCTION	30.5	PY
61923		0.2 NILES TOWER (SP CROSSING)	30.3	IP
		0.6 FREMONT	29.7	P
61924	4042	2.7 PABRICO (SPUR-W)	27.0	P
61927	1230	1.1 UNION CITY	25.9	P
1928	1888	1.0 CARPENTER	24.9	P
61929	1688	4.8 HAYWARD	20.1	P
61934	6922	4.0 ESTUDILLO	16.1	P
61938	3850	1.4 SAN LEANDRO	14.7	P
61939	435	1.0 ELMHURST (SP CROSSING)	13.7	AIP
61940		2.4 KOHLER	11.3	P
61942	3524	0.7 MELROSE (SP CROSSING)	10.6	IP
61946		2.9 CLINTON	7.7	P
		0.5 OAK STREET (SP CROSSING)	7.2	P
61948		1.3 CHESTNUT JCT. (OT CONN.)	5.9	I
		0.1 MAGNOLIA TOWER (SP CROSSING)	5.8	I
61949	YARD	1.1 OAKLAND	4.7	BKF WYPO
		(87.3)		

NOTE: USQM & SP Conn at Lyoth is west connected to east end of Tracy siding.

Rules 80 and 93. Double Track Chestnut Jct. to Clinton. Oakland yard limits continuous from west end of Oakland Yard to Clinton.

Traffic Control System in effect Stockton Yard to Clinton. See Rule 540. Eastward signal D-74 located at MP 7.4 is the distant signal for absolute signal at Clinton.

Rules 105 and 340-A. Siding Tracy is a controlled siding.

Rule T-82-A. Eastward trains do not require a clearance at Oakland.

Rule 541. Before departing Oakland Conductor (or Engineer if there is no Conductor) will contact train dispatcher for instructions for movement Clinton to Stockton. Dispatcher will then issue verbal authority to enter T.C.S. at Clinton.

Conductors will retain orders on inbound train for comparison with train dispatcher for eastward movement.

WESTERN DIVISION

SPEED RESTRICTIONS — FIRST SUBDIVISION

LOCATION	MPH	LOCATION	MPH
Maximum Speed Between MP 92.0 and Chestnut Jct.	60	Midway 58.2 and 52.3	35
Between Mileposts Stockton 92.0 and 90.85	20	Altamont 52.3 and 45.0	50
90.85 and 90.4	45	Livermore 45.0 and 34.4	45
Lathrop Over SP Crossing MP 84.45 (Lathrop)	30	Hearst 34.4 and 29.25	40
Cochran Over SP Crossing MP 74.05 (Lyoth)	50	Estudillo 15.2 (Williams St.) and 10.6 (SP Crossing)	35
Ayala 67.0 and 58.2	40	Melrose 10.6 and 7.7	20
		7.7 and Chestnut Jct.	10

Other Maximum Speeds

MPH

Through turnouts with power-operated switches in reverse position, as follows:

Westward trains leaving Stockton Yard, after receiving signal from rear to indicate rear end has passed Industrial Way, Wyche to Kohler, inclusive, except East Leg of Wye Switch, Niles Jct., and Fremont and through the sidings at the stations and within the limits listed above

20

Trains must move with extreme care not exceeding 3 MPH while moving over frogs and switches and around curves on Tomato Spurs, Tracy.

WESTERN DIVISION BRANCHES

WESTWARD			RENO BRANCH	EASTWARD		
STATION NUMBER	LENGTH OF SIDINGS FEET	THIRD CLASS 209	Timetable No. 7  STATIONS	MILE POST	SECOND CLASS 210	RULE 6(A)
		Daily Except Sunday			Daily Except Sunday	
61616	3000	3.20 AM	RENO JUNCTION	0.0	2.20 AM	YP
60410	480	3.45 AM	PEAVINE (Cal.)	10.1	1.57 AM	
60419	1229	4.06 AM	ANDERSON (Nev.)	18.8	1.36 AM	
60421	2000 17424	4.12 AM	MARTIN#	21.3	1.30 AM	
60423	419	4.20 AM	PANTHER	23.37	1.20 AM	
60425	640	4.30 AM	COUGAR (SPUR-W)	25.4	1.10 AM	
60428	2200	4.40 AM	NORTH RENO	28.3	1.00 AM	R-BKWP
60430	632		COMSTOCK	30.3		
60431	1933		SIERRA PACIFIC (SPUR-E)	30.5		
60433	YARD		RENO	33.1		
			(33.1)			

#Station Leareno Sta. No. 60422 located at end of west connected spur from Martin. Sierra Pacific Spur, MP 30.5, is east connected to west end of Comstock siding. Reno yard limits are continuous from MP 21.3 to Reno.

CLEARANCE REQUIREMENTS AND TRAIN MOVEMENT INSTRUCTIONS

Eastward signal at MP 0.1 is Distant Signal for eastward absolute signal governing entrance to main track, Fifth Subdivision, Reno Jct.

Rule T-82-A. Reno local, Run No. 5743, will assume schedule of No. 210 and will not require a clearance at North Reno. Conductor must contact Train Dispatcher before departing North Reno.

Reno local, Run No. 5743, will assume schedule of No. 209 and will not require a clearance at Reno Jct. Conductor must contact Train Dispatcher before departing Reno Jct.

SPEED RESTRICTIONS — RENO BRANCH

LOCATION	MPH	LOCATION	MPH
Maximum Speed Between Reno Jct. and Reno	25	Martin Spur to Leareno MP 21.3 and MP 30	10 20
Between Reno Jct. MP 0.0 and tail of wye switch	10	North Reno MP 30 and Reno	10
		Reno Interchange connection to SP	5

WESTERN DIVISION BRANCHES

WESTWARD		LOYALTON BRANCH	EASTWARD	
STATION NUMBER	LENGTH OF SIDINGS	Timetable No. 7  STATIONS	MILE POST	RULE 6(A)
	FEET			
61631	5770	HAWLEY	0.0	P
60512	1554	LOYALTON	11.8	
		11.8		

TRAIN MOVEMENT INSTRUCTIONS

Rule 10-H. The first part of the first paragraph of Rule 10-H is modified as follows on the Loyalton Branch.

A metal banner at right of track displaying yellow indicates that trains must reduce speed over track to 10 miles per hour until rear of train has passed temporary resume speed signal unless otherwise directed by train order or bulletin. Such signal must be placed one-fourth (¼) mile before the location is reached where speed of trains must be reduced.

Rule 340-A. Trains arriving Hawley from Loyalton Branch are governed by Rule 340-A.

SPEED RESTRICTIONS — LOYALTON BRANCH

LOCATION	MPH
Maximum Speed, Loyalton Branch	15

WESTWARD		TRACY BRANCH	EASTWARD	
STATION NUMBER	LENGTH OF SIDINGS	Timetable No. 7  STATIONS	MILE POST	RULE 6(A)
	FEET			
61881	10688	TRACY	0.0	WYP
60601	1746	KERLINGER	1.7	
60602		TEEKAY (End of Branch)	1.92	
		(1.92)		

TRAIN MOVEMENT INSTRUCTIONS

Rule 201. Train order authority is not required on Tracy Branch and all movements on branch must be made at yard speed.

Stop and inspect for material covering rail before crossing at MP 0.8.

SPEED RESTRICTIONS — TRACY BRANCH

LOCATION	MPH
Maximum Speed, Tracy Branch Kellogg Spur	10 5

# WESTERN DIVISION BRANCHES

WESTWARD		SAN JOSE BRANCH		↑	EASTWARD	
STATION NUMBER	LENGTH OF SIDINGS	Timetable No. 7			MILE POST	RULE 6(A)
	FEET	STATIONS				
61923		NILES JUNCTION			0.0	YP
60703	534	IRVINGTON (SPUR-W) 3.3			3.3	P
60705	488	INLAND STEEL 1.6			4.9	P
60707	1830	WARM SPRINGS 2.1			7.0	P
60708	830	CURTNER (SPUR-W) 1.0			8.0	P
60711	W3440 E4415	MILPITAS 3.5			11.5	BKWYP
60714	631	BERRYESSA (SPUR-W) 2.6			14.1	P
60717	YARD	SAN JOSE (Yard) 3.4			17.5	BKFWP
60720		VALBRICK (SP X'ing) 2.1			19.6	
60721		WILLOW GLEN (SP X'ing) 0.8			20.4	AI
60722		WEST SAN JOSE (SP X'ing) 1.9			22.3	
60723	YARD	SAN JOSE (End of branch) 0.7			23.0	
(23.0)						

**Rule 540.** Traffic Control System extends from Niles Jct. to Absolute Signals at MP 10.1. Eastward signal at MP 10.1 displays aspects per Rules 288 or 292 only.

**Rule 93.** San Jose yard limits extend from MP 10.1 to MP 23.0, San Jose Branch.

### CLEARANCE REQUIREMENTS

**Rule T-92-A.** Trains do not require a clearance at San Jose or Milpitas.

**Rule 541.** Trains in turnaround service from First Subdivision will retain orders, and before departing Milpitas, Conductor (or Engineer if there is no Conductor) will contact Train Dispatcher before entering T.C.S. for any additional instructions.

**Rule 541.** Trains originating at Milpitas will contact Train Dispatcher before entering T.C.S. for any instructions.

### SPEED RESTRICTIONS — SAN JOSE BRANCH

LOCATION	MPH
Maximum Speed San Jose Branch	35
Between Mileposts Niles Jct. 0.0 and 0.3 including east and west legs of wye.	10
Warm Springs 7.5 and 10.1	25
Curtner 10.1 and 15.7	20
Berryessa 15.7 and 23.0	10

**WESTERN DIVISION  
SACRAMENTO NORTHERN RAILWAY**

WESTWARD		CHICO BRANCH	EASTWARD	
STATION NUMBER	LENGTH OF SIDINGS	Timetable No. 7	MILE POST	RULE 6(A)
	FEET			
61776	YARD	MARYSVILLE (CONN 2ND SUB.)	136.31	
66002	YARD	YUBA CITY (SP CROSSING)	137.27	BOWP
66003	2050	PALORO	138.56	
66004	1365	HARTER	139.43	
66005		COLUSA JCT.	139.77	Y
66014	765	LIVE OAK (SP CONN.)	149.31	
66042	501	DURHAM (SP CONN.)	177.29	
66047		STIRLING JCT. (SP CROSSING)	182.02	
66048	1135	MULBERRY	183.03	Y
66049		CHICO (SP CONN.)	183.37	
	YARD	AIRPORT (END OF TRACK)	189.13	
		(51.44)		

WESTWARD		TARKE BRANCH	EASTWARD	
STATION NUMBER	LENGTH OF SIDINGS	Timetable No. 7	MILE POST	RULE 6(A)
	FEET			
66005		COLUSA JUNCTION	0.0	Y
66105	635	SUTTER	5.24	
66110		TARKE	9.8	
		(9.8)		

WESTWARD		PEARSON BRANCH	EASTWARD	
STATION NUMBER	LENGTH OF SIDINGS	Timetable No. 7	MILE POST	RULE 6(A)
	FEET			
61779	1160	CLEVELAND (CONN. 2ND SUB)	134.4	P
66202	405	ALICIA	132.36	
66205	260	PEARSON	129.70	
66206	260	REED (SPUR-E)	129.14	
		(5.26)		

**Rule 201.** Train order authority is not required on Chico, Tarke and Pearson Branches and all movements must be made at yard speed.

**Rule 701.** For movements over SPT Co. Trackage, Live Oak to Durham governed by SPT Co. Rules and Time table.

**Tarke Branch.** No movements will be made between Sutter and Tarke without authority from Superintendent or his representative.

**SPEED RESTRICTIONS —  
SACRAMENTO NORTHERN RAILWAY**

LOCATION	MPH
<b>Chico Branch</b> Maximum Speed Between Marysville and Live Oak	<b>10</b>
Marysville, Jct. 2nd Sub, MP 136.31 Marysville All Street Crossings MP 137.08, SP Crossing, except on proceed Signal from Flagman	<b>Stop Stop and Flag Stop</b>
Maximum Speed Between Durham and Chico	<b>10</b>
Durham Highway Crossing, MP 177.5 Stirling Jct., SP Crossing, MP 182.02	<b>Stop and flag Stop</b>
<b>Tarke Branch</b> Maximum Speed	<b>10</b>
Colusa Jct. Township Rd., MP 1.6 Sutter Hwy Crossing, MP 5.1	<b>Stop and flag Stop and flag</b>
<b>Pearson Branch</b> Maximum Speed	<b>10</b>
<b>Pearson</b> Hwy Crossing, MP 129.4	<b>Stop and flag</b>

**WESTERN DIVISION  
SACRAMENTO NORTHERN RAILWAY**

WESTWARD		RIO LINDA BRANCH	EASTWARD	
STATION NUMBER	LENGTH OF SIDINGS	Timetable No. 7	MILE POST	RULE 6(A)
	FEET			
61802	1185	SANKEY 0.48	109.65	
61802		SANKEY (CONN. 2ND SUB) 6.07	109.17	P
66306	1225	RIO LINDA (6.55)	103.1	

WESTWARD		WOODLAND BRANCH	EASTWARD	
STATION NUMBER	LENGTH OF SIDINGS	Timetable No. 7	MILE POST	RULE 6(A)
	FEET			
	YARD	WESTSIDE 0.10	92.40	BKW
66501		ABSS } BRODERICK 1.55	92.30	Y
66402		MIKON (SP CROSSING) 1.18	1.55	AIP
66403	660	LOVDAL 9.08	2.73	
66412		CONAWAY (SPUR-W) 2.99	11.81	
66415	330	HEBRON (SPUR-E) 1.77	14.80	
66417	YARD	WOODLAND (16.67)	16.57	

WESTWARD		HOLLAND BRANCH	EASTWARD	
STATION NUMBER	LENGTH OF SIDINGS	Timetable No. 7	MILE POST	RULE 6(A)
	FEET			
66501		BRODERICK 0.06	92.30	Y
	YARD	WEST SACRAMENTO 0.68	92.24	
66502	YARD	WESTGATE 0.62	91.56	O
66503		SACRAMENTO-YOLO PORT CONN. 3.99	90.94	
66507	2160	RIVERVIEW 5.89	86.95	
66513		CLARKSBURG (SPUR-S-W) 2.77	5.89	
66516		CENTRAL (SPUR-W) 4.54	8.66	
66523	1245	SORROCA 1.06	13.20	
66524	1005	VALDEZ 1.51	14.26	
66526	680	OXFORD (21.12)	15.77	

**TRAIN MOVEMENT INSTRUCTIONS**

**RULE 201.** Train order authority is not required on the Rio Linda, Woodland and Holland Branches and all movements must be made at yard speed.

**Holland Branch.** Main track Riverview out of service. Switches lined and spiked for siding. Main track, Holland Branch, out of service from a point ½ mile west of Clarksburg.

**SPEED RESTRICTIONS — SACRAMENTO NORTHERN**

LOCATION	MPH
<b>Rio Linda Branch</b> Maximum Speed	<b>10</b>
<b>Sacramento Yard</b> Between Haggin and MP 90.66 (SN Trackage) 2nd Sub Conn. "C" St. and CPC 11 Sacramento-Yolo Port RR	<b>20</b> <b>5</b> <b>10</b>
<b>Woodland Branch</b> Maximum Speed Between Mileposts Broderick 0.37 and 0.48 (Joint Track)	<b>20</b> <b>10</b>
Mikon 1.55 (SP Crossing)	<b>Stop</b>
Lovdal 8.0 (Over Kiesel Hwy Crossing) 10.17 and 11.71 (Fremont Trestle)	<b>15</b> <b>10</b>
Hebron 16.24 and 16.67 (Woodland City Limits)	<b>10</b>
<b>Holland Branch</b> Maximum Speed	<b>20</b>
Over Bascule Bridge, MP 90.66 Linden Rd. MP 89.7 Davis Rd. MP 88.5	<b>10</b> <b>Stop and flag</b> <b>Stop and flag</b>
Riverview Between Riverview and Oxford Jefferson Blvd. MP 10.40	<b>10</b> <b>Stop and flag</b>

**WESTERN DIVISION  
SACRAMENTO NORTHERN RAILWAY**

WESTWARD		PITTSBURG BRANCH		EASTWARD		
STATION NUMBER	LENGTH OF SIDINGS	Timetable No. 7			MILE POST	RULE 6(A)
	FEET	STATIONS				
61818 61862 66931	YARD YARD YARD	2ND SUB-TCS ATSF ABS	SO. SACRAMENTO STOCKTON YD. EAST PITTSBURG (JCT. ATSF)		JOINT TRACK 48.46	P
			0.4 ATSF CROSSING		48.06	
			0.67 ATSF CROSSING		47.39	
66932	YARD		0.44 PITTSBURG		46.95	
			0.71 ATSF CROSSING		46.24	
66933	510		1.32 WEST PITTSBURG		44.92	Y
66935			1.33 SHELL POINT (SPUR-W)		43.59	
66936	830		1.13 MCAVOY		42.46	
66937			1.52 NICHOLS (SPUR-W)		40.94	
66939	680		1.91 PORT CHICAGO		39.03	
66941			1.82 CLYDE		37.21	
			(11.25)			

WESTWARD		VACAVILLE BRANCH		EASTWARD		
STATION NUMBER	LENGTH OF SIDINGS	Timetable No. 7			MILE POST	RULE 6(A)
	FEET	STATIONS				
61815	YARD		HAGGIN		95.49	P
			0.51 19TH ST., (JCT. SP) CANNON, (JCT. SP)		94.98 7.87	P PY
66682		SP ABSS	2.34 VACAVILLE JCT. (SPUR-W)		7.60	
66685	205		4.21 VACAVILLE		4.21	
			(7.06)			

WESTWARD		DOZIER BRANCH		EASTWARD		
STATION NUMBER	LENGTH OF SIDINGS	Timetable No. 7			MILE POST	RULE 6(A)
	FEET	STATIONS				
66681			CANNON		6.94	Y
66708	965		6.94 DOZIER		64.55	Y
66718	1425		9.57 LIBFARM		74.12	
			1.34 END OF TRACK		75.46	
			(17.85)			

WESTWARD		MONTEZUMA BRANCH		EASTWARD		
STATION NUMBER	LENGTH OF SIDINGS	Timetable No. 7			MILE POST	RULE 6(A)
	FEET	STATIONS				
66708	700		DOZIER		64.55	
66805	680		4.75 CREED-ATLAS POWDER CO. (SPUR-W)		59.80	
66807	320		2.02 RIO VISTA JCT. (SPUR-W)		57.78	
66813	786		5.81 MOLENA		51.97	
66815			1.99 MONTEZUMA		49.98	
			(14.57)			

**TRAIN MOVEMENT INSTRUCTIONS**

**Rule 201.** Train order authority is not required between East Pittsburg and Clyde, between Cannon and Vacaville and on Dozier and Montezuma Branches and all movements must be made at yard speed.

**Dozier Branch.** Track out of service between Northgate Road, MP 6.4, and Dozier.

**Montezuma Branch.** Track between Rio Vista Jct., MP 57.78 and Montezuma is out of service. Before movements are made between Dozier and Rio Vista Jct., Roadmaster's permission must be secured.

**Rule 701.** Movements over SPT or ATSF trackage are governed by their respective rules and timetables.

**SPEED RESTRICTIONS — SACRAMENTO NORTHERN RAILWAY**

LOCATION	MPH
<b>Pittsburg Branch</b> Maximum Speed	<b>20</b>
East Pittsburg Between MP 48.06 and MP 46.66 ATSF Crossings, Columbia St., MP 48.06, and Harbor St., MP 47.39	<b>10</b>
Over ATSF Crossing MP 46.24	<b>Stop and flag 10</b>
West Pittsburg Wye Tracks	<b>5</b>
Port Chicago Main St., MP 39.2 Norman Rd., MP 37.8	<b>Stop and flag 15</b>
<b>Vacaville Branch</b> Maximum Speed	<b>20</b>
<b>Dozier Branch</b> Maximum Speed Northgate Rd., MP 6.4	<b>10 Stop and flag</b>
<b>Montezuma Branch</b> Maximum Speed Gum Grove Highway MP 53.9	<b>10 Stop and flag</b>

**WESTERN DIVISION**

WESTWARD		TIDEWATER SOUTHERN		EASTWARD	
STATION NUMBER	LENGTH OF SIDINGS	Timetable No. 7		MILE POST	RULE 6(A)
	FEET	STATIONS			
61862	YARD	YD LMTS.	STOCKTON YARD	0.0	TO-R-BK OWYP
61864			ORTEGA	1.7	
65002	311		VALIMET (SPUR-E)	2.2	
65003	1405		SHARPS LANE (SPUR-E)	3.3	
65005	2170		MANTECA JCT.	5.2	
65006	1065		TURNER	6.2	
65012	1625		ATLANTA	12.5	
65014	1040		SIMMS (Yd. Limits)	14.2	
65017	1160		ALBA	17.0	
65020	1390		ESCALON (Yd. Limits)	19.8	
65026	1220		MCHENRY	25.6	
65029	2310		AURORA	29.5	
65030	YARD		NORTH YARD JCT.	30.1	
65032	YARD		MODESTO	31.6	BWP
			SP CROSSING	32.7	IP
65034	1635		MOORE (SPUR-E)	33.2	
65035	2010		ROGERS	34.5	
65037	200		BRONCO (SPUR-W)	37.5	
65042	1240		HATCH	41.6	Y
65045	YARD	KEARNEY	44.7		
65048	YARD	TURLOCK	47.9		
			(47.9)		

WESTWARD		MANTECA BRANCH		EASTWARD	
STATION NUMBER	LENGTH OF SIDINGS	Timetable No. 7		MILE POST	RULE 6(A)
	FEET	STATIONS			
65005	2170	YD LMTS.	MANTECA JCT.	0.0	
65105	1040		MANTECA	5.1	
65107			SOUTH MANTECA	6.6	
			(6.6)		

WESTWARD		CHEMURGIC BRANCH		EASTWARD	
STATION NUMBER	LENGTH OF SIDINGS	Timetable No. 7		MILE POST	RULE 6(A)
	FEET	STATIONS			
65042		YD LMTS.	HATCH	0.0	Y
65203			CHEMURGIC	2.9	
			(2.9)		

**SPEED RESTRICTIONS — TIDEWATER SOUTHERN RAILWAY**

LOCATION	MPH
<b>Maximum Speed</b>	
Between MP 1.7 and MP 25.3	35
Between MP 25.3 and Turlock	20
Between Mileposts	
Ortega	
1.7 and 5.8	20
<b>Simms</b>	
MP 14.2 Hwy Crossing	20
<b>Alba</b>	
MP 17.0 Winery Spur Hwy Crossing	Stop and flag
19.0 and 21.0	20
Escalon	
22.53 and 23.13 (Stanislaus River Bridge and curve east and west of bridge)	20
McHenry	
MP 27.2 and 9th & P Sts. Modesto	15
North Yard	10
Tully Rd.	Stop and flag
Coldwell Ave. — Lyng Spur	Stop and flag
Modesto	
9th and P Sts. and MP 33.3	10
Kearney	
46.5 and 47.9 Turlock	10
Broadway St. Crossing	Stop and Flag
<b>Chemurgic Branch</b>	
Maximum Speed	20
<b>Manteca Branch</b>	
Maximum Speed	20
4.0 and 6.632 (end of branch)	10
Spreckels Hwy Crossing	Stop and flag

When handling more than fifty (50) cars or 5,000 tons or fifteen (15) or more loaded covered hoppers, do not exceed 25 MPH on Tidewater Southern.

# WESTERN DISTRICT SPECIAL INSTRUCTIONS — ALL SUBDIVISIONS INCLUDING TIDEWATER SOUTHERN AND SACRAMENTO NORTHERN

Except as otherwise stated here or in appropriate location in Western District portion of Timetable or by subsequent bulletin, Special Rules — System in this timetable will not apply to the Western District.

The following Special Rules — System will apply to Western District.

Definition "Tons Per Operative Brake".

Definition "Horsepower Per Trailing Ton".

Under "Standard Time", approved wrist watches.

Appendices 12 13-13a and 14 — Handling hazardous materials. Note: Rule reference for Western District is Rule 728.

**Rule 1-A.** All times shown are Pacific Time.

**Rule 228-Z. Dimensional Shipments.** Conductors determining that there are dimensional shipments or cars in their train and that such shipments are not covered by train order Form Z or by message Form T-5 on blue paper, when such shipments will move through, or are destined to Nevada or California points, and exceed 5'5½" from centerline of car, will notify Dispatcher of such condition and will be governed by Dispatcher's instructions in the further handling of such shipment or car.

Conductor will advise Train Dispatcher when setting out a High-Wide shipment or car for any reason and will not make such set-out without Dispatcher's authority.

**Rule 1137 (T).** Use of retaining valves.

On descending grade, when locomotive dynamic brake and train air brakes will control speed of train, and total brake pipe reduction does not exceed 13 pounds (½ the normal full service train brake available) the use of retainers will not be required. Also, if dynamic brake becomes inoperative and total brake pipe reduction required to control train speed does not exceed 13 pounds, the use of retainers will not be required.

Between the following points, if total brake pipe reduction required to control train speed exceeds 13 pounds, stop must be made immediately, train secured by use of hand brakes and air brake system fully recharged (per Rule 1114). After air brake system is fully recharged, if proper control of train speed cannot be maintained, retainers will be used as follows:

### Westward

MABIE to Oroville Yard — One retainer for each 250 Tons in train. (Ruling Grade 1%)

MP52 to Westwood — One retainer for each 220 Tons in train. (Ruling Grade 1.5%)

ALMANOR to Greenville — One retainer for each 150 Tons in train. (Ruling Grade 2.2%)

### Eastward

HALLS FLAT to Little Valley — One retainer for each 200 Tons in train. (Ruling Grade 1.8%)

SILVER ZONE to Wendover — One retainer for each 250 Tons in train. (Ruling Grade 1%)

When it is known before reaching any of the above locations that the use of retainers will be necessary, stop must be made and required number of retainers set before leaving the initially named points.

On other descending grades if the use of retainers becomes necessary, stop must be made, train secured by the use of hand brakes while the air brake system is fully recharged (per Rule 1114) and sufficient retainers set to control speed of train.

When retainers are used they will be applied to cars on head end in a block of not less than ten cars. Retainers are to be used in the low pressure (horizontal) position. Should wheels show a tendency to heat, retainers must be alternated.

When retainers are no longer required, they should be placed in the direct exhaust position (handle turned downward).

### Formulae

1 % = 6000 Ton — 250 Ton per = 24 Retainers

1.5% = 6000 Ton — 220 Ton per = 27 Retainers

1.8% = 6000 Ton — 200 Ton per = 30 Retainers

2.2% = 6000 Ton — 150 Ton per = 40 Retainers

vs. 100%

## SPECIAL INSTRUCTIONS — EASTERN DIVISION SALT LAKE CITY

When operating between 10th West and North Yard, be governed by applicable instructions under SOUTH CENTRAL DISTRICT, UTAH DIVISION, Special Rules — Salt Lake City Terminal Area.

### Pollard Jct. and Roper Yard Instructions

Eastward and westward freight trains will enter and leave D&RGW running tracks through interlocking between Pollard Jct. and 1st So. St., Salt Lake City. Trains must keep to the right. Movement against current of traffic on these two running tracks will be made in accordance with D&RGW Operating Rule 93. Eastward trains arriving Roper, unless otherwise instructed, will stop at 21st So. St. and get track instructions from yardmaster through the two-way speaker located near 21st So. St.

Audible annunciator located 430 feet west of 13th South St. A sign reading, "Grant Tower Annunciator" has been installed at this location and the following whistle signals will be given:

UP trains and engines departing.oooo. (enroute Western District.)

Ogden trains and engines departing \_\_\_\_\_.

Engines moving Roper to North Yard.oo.

**Rule 701.** When operating in joint yard territory east of T.C.S. limits, Pollard Jct. (MP 927.2), crews will obey instructions of terminal officers, including D&RGW officers having supervision over the terminal and, in addition to WP rules, will be governed by D&RGW Rule 93, which reads as follows:

Yard limit rules will be indicated by yard limit signs and designated in the timetable.

Within yard limits main tracks may be used without protecting against other trains or locomotives.

All trains and locomotives must move within yard limits at restricted speed, prepared to stop within one half the range of vision unless main track is known to be clear by ABSB indication.

Movement against the current of traffic on the main tracks must not be made unless authorized and protected by Yardmaster or other designated official.

Restricted speed. Speed that permits stopping short of another train or obstruction; but not to exceed 20 MPH.

## SPECIAL INSTRUCTIONS EASTERN DIVISION SEVENTH SUBDIVISION

### Garfield Pit, KCC Interchange

**Rules 550, 550-A, 551, and 551-A.** Pit Tracks 1 and 2, TIP 801 and 802, north of main track at MP 911.7, will be used for interchange of cars with KCC. KCC trains and engines will contact train dispatcher for authority to use joint track between eastward absolute signal at Smelter and eastward absolute signal at West Garfield.

### Flood Detectors.

Located on south side of track at twenty-five points between MP 797.5 and MP 788.46, interconnected with signal system.

### Dyke

**Rule 552.** West-connected hand-throw switch at Dyke (MP 795.7) between Pilot and Ola is in service. This switch is not electrically locked and trains or engines must not clear main track at this station.

### Shafter

Engines must not exceed 10 MPH on straight track and 5 MPH on turnouts in NN yard and are prohibited from using NN rip track.

**Rule 103-B.** Nevada Northern crossing must not be blocked while switching.

### Alazon

**Rule 509, SP Rule 776.** C.T.C. controlled by SP dispatcher, Eastward home signal governs movements to SP or to enter T.C.S. on UP main track. When STOP indication is displayed and movement via UP is desired, Rule 509 will apply. When STOP indication is displayed and movement via SP is desired, SP Rule 776 will apply. ("A" applies to UP only and "SA" applies to SP only.)

**SP Rule 772.** Dual-control switches are under control of SP dispatcher. When necessary to hand-throw these switches, permission must be obtained from dispatcher and be governed by SP Rule 772.

**SP Rule 535.** West switch of crossover between SP and UP main track is a spring switch and normal position is for SP main track. Movements over this switch must be made in accordance with SP Rule 535.

**Rule 540.** Eastward trains may leave Alazon without contacting the train dispatcher when eastward home signal indicates PROCEED and will retain their identity.

### Project Track, MP 670.7

**Rule 545.** Dual control switch at MP 670.7 is locked in hand-throw position. Permission from train dispatcher to use is not required.

### Elko

**Rule 550.** Crossover, Third St. UP Elko yard. Inside siding switch of crossover electrically-locked. Release of electric lock must be obtained before main track switch is lined. Instructions for operating the lock are posted in electric lock case.

Dwarf signal governing westward movements, located between main track and siding, at MP 665.5. Approach lighting circuit starts 300 feet east of Signal 6655.

**Rule 104-D.** Spring switch, 12th Street, east end of old main track, UP Elko yard, normally lined for eastward main track and may be trailed through eastward onto main track.

Trains or engines trailing through spring switch old main track to main track East Elko must not exceed 5 MPH until engine is on 12th St. Crossing then 20 MPH through switch.

Westward trains and engines must stop and examine switch points before moving over spring switch, East Elko.

**Rule 291.** Eastward trains leaving Elko on old main track finding Signal 6660 displaying aspect per Rule 291, must stop short of signal and operate push button. Eastward trains leaving Elko on main track finding signal 6662 displaying aspect per Rule 291 must stop and operate push button when there is an eastward train on old main track. Instructions for operating push buttons are posted in push button housings.

Telephone located on instrument case south side of tracks opposite Signal 6662 for purpose of contacting train dispatcher when Signal 6660 or 6662 does not clear promptly after push button operation. If signal continues to display aspect per Rule 291 after

expiration of time release interval, train may proceed at restricted speed after obtaining permission from train dispatcher.

Dwarf signal located 250 feet west of spring switch at east end of old main track Elko, governs movements against current of traffic on main track to dwarf signal 6655 located at 4th St., Elko.

East detour extends from SP siding to UP freight yard, Elko.

## SPECIAL INSTRUCTIONS — EASTERN DIVISION SIXTH SUBDIVISION

### East Carlin

**Rule 509.** Detour extends from East lead on SP to East Carlin on UP. Movements over dual-controlled power operated switch are governed by absolute signals bearing the letter "A." Trains or engines finding these signals displaying aspect per Rule 292 will be governed by WP Rule 509.

### Carlin

**Rule 334.** When trains on which crew changes are made at Carlin are departing, they must move at restricted speed until reaching a point where next signal indication can be clearly seen and intervening track can be seen to be clear.

**Rule 99.3.** All SP switch movements on UP main track between West Carlin and East Carlin must be made with authority UP train dispatcher and under provisions of Rule 99.

### West Carlin

**Rule 663.** Main track detour switch at MP 643.4 is interlocked. Interlocking limits extend from home signal MP 643.4, located 100 feet west of remote-controlled switch, to dwarf home signal, located 350 feet east on main track, governing westward movements, and to dwarf home signal, located 350 feet east on detour, governing westward movements to main track. Dwarf signals will display aspects per Rule 288 or 292 only and govern only to end of interlocking limits opposite eastward home signal where non-block signal territory commences.

If signals indicate STOP be governed by Rule 663. If route is not properly lined, call signal operator and obtain authority to operate this dual-controlled switch by hand.

SP passenger trains and light engines, and other trains when so instructed, are authorized to use UP main track at Carlin provided Signal 643.4 indicates proceed on UP main track. If signal 643.4 indicates movement over west detour to SP yard, such trains will enter detour and proceed to SP yard at Carlin.

West Carlin detour extends from remote-controlled switch on UP main track at West Carlin to connection with SP main track at west end of Carlin yard.

### Valmy

**Rule 509.** Power switch and associated eastward and westward absolute signals bearing letter "A" are located at Valmy, MP 572.2 serving Sierra Pacific Power. Rule 509 applies.

Westward absolute signal at Valmy may display aspects per Rules 288, 288-A and 292 and governs movements over switch only.

### Impaired Clearances

**Valmy.** Impaired clearance on west side of coal unloading structure at North Valmy Power station. Automatic unloading feature is operated by a live third rail which makes physical contact with actuating shoes on each car. Members of crew must not use walkways or ride on the sides or tops of cars while train is being operated over trestle.

### Weso

**Rules 509-540.** T.C.S. controlled by UP train dispatcher. Westward home signal governs movements to SP or to enter T.C.S. on UP main track. When STOP indication is displayed and movement via UP is desired, WP Rule 509 will apply. When STOP indication is displayed and movement via SP is desired, SP Rule 776 will apply.

When eastward signal on SP is at stop and movement is desired to UP, Rule 509 applies and application will be made as though signal bore the letter "A."

Westward movement from UP A.B.S.S. to UP "enter T.C.S." will be made by signal indication. If signal fails to display proceed indication WP Rule 509 will apply.

**SP Rule 776.** Obtain permission from the UP train dispatcher for movement from UP track to SP track over crossovers and be governed by SP Rule 776.

**Rule 545.** Switches on SP end of crossovers are dual-control. Permission of UP train dispatcher is required for hand operation.

**Rule 104-D.** Spring switches on UP end of crossovers are normally lined for UP track.

**Rules 545 and 550.** Electric lock on west crossover spring switch releases when the power switch on this crossover has been reversed by the UP train dispatcher.

Instructions for operation of dual-control switches and electric switch locks are posted in telephone booths located at signal.

## EASTERN DIVISION SIXTH AND SEVENTH SUBDIVISIONS Use of UP Portion of Paired Track Between Weso and Alazon Inclusive

Between Weso and Alazon, track of UP and SP will be used jointly. All eastward trains of both companies will use UP track, and all westward trains of both companies will use SP track, unless otherwise instructed.

### Movements against current of traffic.

Current of traffic on UP track, Weso to Alazon, is eastward. Movements against the current of traffic must not be made except under flag protection or as authorized by train order.

**Rule 408.** Manual block may be established by train order.

**Rule 228-G,H.** Train dispatchers will use following form of train order to authorize movement of a westward train or to create a work extra.

Example 1: "Eng.....run extra on UP track.....to....."

Example 2: "Eng.....works extra on UP track.....M  
until.....M between.....and....."

**Rule 19.** When the rear car of an SP passenger train is equipped with a combination oscillating red light and auxiliary green marker light, oscillating red light must be displayed by day as well as by night when train is on main track, and when so displayed, will be considered as markers. Oscillating red light must be extinguished and green marker light displayed when train has stopped clear of main track to be met or passed by another train.

**Rule 21.** Suspended between Weso and Alazon. Extra trains will be identified by engine number. See Rule 24.

**Rule 825 (T).** Southern Pacific trains operating on UP track between Carlin and Alazon that have a helper behind a caboose consisting of not more than one (1) unit are exempt from complying with that part of Rule 825 reading — "Employees must vacate such caboose and ride in locomotive" and that part reading — "When helper is used behind a caboose the speed of the train must not exceed 20 MPH."

**Rule 14. Engine whistle signals.**

**Carlin:** Westward: Approaching east end yard:

SP freight trains, o — o.

UP trains, — o.

**Alazon:** Eastward UP trains must sound whistle signal o — — at sign reading "UP WHISTLE" located at MP 706 Pole 21.

UP station numbers, SP paired track.

Tulasco (SP)	
Halleck	61271
Osino	61284
Moleen	61304
Vivian	61311
Palisade	61321
Harney	61330
Mosel	61355
New Argenta	61357
Argenta	61358
Imco	61359
Hilltop	61360
Battle Mountain	61371
Mote	61381
Iron Point	61394
Tule	61420

### Winnemucca

**Rule 105-B.** First track south of main track will be used as a siding for the meeting and passing of trains. All switches except main track switches must be left lined for this track when switches not in use.

**Rules 104-A, 26-C(c)(1).** A second derail has been installed on H&H Spur, Winnemucca, to protect unloading of tank cars. The two derrails are located 400 feet and 795 feet from clear point of H&H switch off North Siding.

## SPECIAL INSTRUCTIONS — EASTERN DIVISION FIFTH SUBDIVISION (To But Not Including Flanigan)

### Gerlach

**Rule 105.** U.S. Gypsum Co. engine uses east end of siding Gerlach as a tail track when delivering or receiving cars from UP Co. When using siding Gerlach, approach east end of siding looking out for U.S. Gypsum Co. engine.

**Rule 104-A.** Switch at west leg of wye and Balloon Track is to be left lined and locked for Balloon Track. This does not relieve employees using this switch from knowing its position prior to use.

## SPECIAL INSTRUCTIONS — EASTERN DIVISION BRANCHES

**Rule 10-H.** The first part of the first paragraph of Rule 10-H is modified as follows on the Warner, Ellerbeck, Rowley and Marblehead Branches.

A metal banner at right of track displaying yellow indicates that trains must reduce speed over track to 10 miles per hour until rear of train has passed temporary resume speed signal unless otherwise directed by train order or bulletin. Such signal must be placed one-fourth (¼) mile before the location is reached where speed of trains must be reduced.

### Warner Branch

#### Marshall

Gate installed across track at MP 6.8 just east of Highway 40 crossing. Gate must be opened to permit train movement and must be closed as soon as movement has passed.

### Ellerbeck Branch

**Rule 104-A. Wye.** West switch east leg of Wye must be left lined for straight track as derail. East leg of wye out of service.

**Dolomite.** Look out for poor footing both sides of track on curve just east of plant, and all tracks vicinity plant. Main track and No. 1 track are out of service 630 feet east of west switch acc't dirt on and along tracks.

**Flux.** Main track out of service 200 feet east of west switch, run around track.

## SPECIAL INSTRUCTIONS — WESTERN DIVISION FIFTH SUBDIVISION (FLANIGAN TO PORTOLA)

### Flanigan

Connection to SP at MP 384.4. Connection switch east connected and is equipped with a dual-control power-operated switch.

Westward absolute signal governing movement over connection is a two-unit signal. Upper unit governs movement to UP main track. Lower unit has lunar light indicators mounted on signal mast which indicate as follows:

Lunar light illuminated to the right of the mast indicates route lined to SP connection.

Lunar light illuminated to the left of the mast indicates route lined for UP into Flanigan siding.

Movement through connection to UP main track is governed by absolute signal located at clear point west end SP double track Flanigan, (SP MP 336.51).

**Rule 509.** All signals governing movement through SP connection MP 384.4 are absolute signals under control of UP train dispatcher. "SA" and "P" apply to SP trains only. WP Rule 509 applies.

**Rule 542.** SP train may enter or leave UP track on PROCEED signal indication, without member of crew contacting train dispatcher, but must contact UP train dispatcher promptly if they are unable to comply with authority granted by signal aspect.

### Pozla

**Rules 104-A and 552.** Split point derail east end. Switches are not electrically locked. Do not clear main track unless main track switch is open continuously. See Rule 552.

### Tunnel 37

**Rule 288.** Slide detector device is in service in Tunnel 37. Eastward absolute signals at East Chilcoot and Westward absolute signals at Reno Jct. may display aspect per Rule 288, which will indicate a detector device has been actuated and trains may proceed not exceeding restricted speed.

### Permasco Skates

**Rule 103-C. Hawley:** At east end of run-around track and at west end of Stock Track.

**Reno Jct.:** On post at clear point between east leg of Wye and Reno branch. See section entitled "Permasco skates" under Third Subdivision for instructions regarding their use.

### Portola

**Rule 105-B.** No. 1 track designated as siding, to include all drill tracks to main track at each end of yard.

**Rule 545.** Derail at west end siding Portola is power operated and when switch is in hand operated position, derail, if used, must also be hand operated.

**Rule 104-A.** Derail at west end of west siding is hand operated, independent of switch. Derail will actuate signals on main track when not in derailing position.

## SPECIAL INSTRUCTIONS — WESTERN DIVISION FOURTH SUBDIVISION

### Bieber

**BN Rule 93.** Trains will be governed by Burlington Northern Inc. timetable and transportation rules. Applicable portion of Rule 93, Burlington Northern Inc. Rules reads as follows:

The main track(s) within yard limits may be used clearing the time of first class trains when due to leave the last station where time is shown. In Non-ABS territory, in case of failure to clear the time of first class trains, protection must be provided as prescribed by Rule 99. Protection against second and third class trains, extra trains and engines is not required.

All trains and engines, except first class trains, must move within yard limits prepared to stop short of train, engine, car, stop signal, derail or switch not properly lined and prepared to stop in one-half the range of vision but not exceeding 20 MPH, unless main track is known to be clear by block signal indication.

**BN Rule 93.** Does not relieve trains from complying with WP Rules T-86 and T-87.

### Westwood

**Rule 105-B.** No. 2 track and old electric siding connected with No. 2 track at west end will be used as siding.

**Rule 104-A.** Derail on west end old electric siding must be kept in derail position except when being used. Both siding switches equipped with electric locks. West switch must be unlocked before removing derail. East switch of old electric siding must be left lined for siding.

### Clear Creek Junction

**Rule 93.** The 33-car siding is the interchange track with Almanor Railroad Company and trackage between UP main track switch and yard limit board 2000 feet beyond end

of the 33-car siding toward Chester is joint track for interchange purposes. Movements over this trackage are under operating rules governing operations within yard limits. Switch point derail on Almanor RR main track 400 feet from junction switch.

**Rule 104-A.** Normal position junction switch lined for UP main track. Rule 552 applies.

**Rule 552.** Hand throw switches at the following points are not equipped with electric locks. Clear Creek Jct., Almanor House Track and Wye, Crescent Mills. Rule 552 applies. Trains and engines must not clear main track at these switches.

### Keddie

**Rule 14.6.** When calling in flagmen from east on Fourth Subdivision, enginemen will sound six long blasts of horn.

**Rule 301.** Upper unit of 2-unit absolute signal governs eastward movement from inside tracks Keddie to the Fourth Subdivision.

**Rule 288.** Absolute dwarf signal on Fourth Subdivision lead when displaying aspect per **RULE 288** will govern westward movement from Fourth Subdivision to siding or yard.

### Dial Phones

Located at East Keddie Wye, West and East Moccasin, Crescent Mills, East Greenville, West and East Almanor and middle of siding Almanor, Clear Creek Jct., MP 38.6, booth east end of Westwood, West and East Robbers Creek and Highway 44 (MP 55.8). To contact 4th Sub Dispatcher, dial "7" on message line. To contact 3rd Sub Dispatcher, dial "6" on message line.

### Permasco Car Skates

**Rule 103-C.** Located at Little Valley, Lodgepole, Robbers Creek, Greenville and Moccasin.

When setting cars out on any of these sidings, see that they are used. If cars already on siding, arrange to couple cars to be set out with the cars already there, resetting skates under outside pair of wheels of truck of first car on down hill side. When coupling into car or cars on siding, make coupling carefully and see skates removed before cars are pulled or pushed.

When all cars are removed from siding, crew making pickup will see skates are rehung on post or pole in place provided.

In addition to the use of Permasco skates, a sufficient number of hand brakes must be set. Cars must be coupled if practicable. Wheels must be further blocked if necessary to prevent their movement.

## SPECIAL INSTRUCTIONS — WESTERN DIVISION THIRD SUBDIVISION

### Keddie

**Rule 104-A.** All switches leading in or out of siding (No. 1 track), must be left lined for the siding.

**Rule 545.** Inside crossover switch at the west end of siding is dual-control power-operated and, when in power position, works simultaneously with west siding main track crossover switch. When west siding main track crossover switch is in hand-operated position, inside crossover switch must also be hand-operated.

### Grays Flat Spur, MP 272.6

Cars must not be left at top of hill or on descending grade on this spur.

### Twain

**Rule 550.** Electric locked switches. Hand operated derail at west end is connected to track circuits. Derail must not be thrown until electric locked switch has been unlocked and must be placed in derailing position before locking main track switch.

### Permasco Car Skates

**Rule 103-C.** Located at Mabie — on south side at clear point, west end. Paxton and Twain — approximately 15 car lengths east of west switch and 15 car lengths west of east switch. In addition, are on tie posts at the following locations: East James — North Side; West James — South Side; East Elsey — South Side; West Elsey — North Side; East Kramm — North Side; West Kramm — South Side; East Oroville (Depot Siding) — North Side; West Oroville (Depot Siding) — South Side.

The posts are placed approximately 250 feet (5 car lengths) East of the West siding signals and approximately 500 feet (10 car lengths) West of the East siding signals.

When setting out cars on any of these sidings, see that skates are used. If cars already on siding, arrange to couple cars to be set out with the cars already there, resetting skates under outside pair of wheels of truck of first car on the down hill side. When coupling into car or cars on siding make coupling carefully and see skates removed before cars are pulled or pushed.

When all cars are removed from siding crews making pick up will see skates are rehung on post or pole in place provided.

In addition to the use of Permasco skates a sufficient number of hand brakes must be set. Cars must be coupled if practicable. Wheels must be further blocked if necessary to prevent their movement.

### Detector Devices

**Rule 288.** At locations listed below, aspect per Rule 288 will indicate a detector device has been actuated and train may proceed not exceeding restricted speed looking out for rocks on track or other condition which would have actuated the detector device.

Eastward Absolute Signal at Rich Bar and Westbound Signal 2675.

Eastbound Signal 2576 and Westbound Absolute Signals at West Belden.

Eastbound Signals 2362 and 2368, Westbound Signals 2371 and 2379 and Westbound Absolute Signals at West Pulga.

### Dragging Equipment Detectors

Located as follows:

MP 279.4 between Keddie and Paxton.  
MP 275.5 between Paxton and Twain.  
MP 273.5 at Twain.  
MP 267.4 between Virgilia and Rich Bar.  
MP 262.5 between Rich Bar and Belden.  
MP 257.7 between Belden and Camp Rodgers.  
MP 253.46 at Tobin.  
MP 249.3 between Tobin and Merlin.  
MP 245.6 between Merlin and Cresta.  
MP 241.5 between Cresta and Pulga.  
MP 234.2 at West Poe.  
MP 222.2 between James and Elsey.

When head end of train passes detector, lunar indicator lights adjacent to detector location will give steady aspect. If the detector is activated, the lunar indicator lights will flash. When indicator lights are flashing, train must be stopped promptly and inspection made.

### Oroville Yard

**Rule 545.** Main track and inside crossover switches at east end of train yard, MP 203.75, are dual-control. When either switch is placed in hand-throw position, the other switch is disconnected from power operation and it is then unnecessary to place it in hand-throw position.

Signals governing movement over inside dual-control switch are controlled by the train dispatcher. When these signals display aspect per Rule 288, movements may be made over this switch without placing it in hand-throw position. If signals display STOP aspect per Rule 292 and reason is not apparent, or if call light is lighted on adjacent telephone booth, train dispatcher must be contacted promptly.

**Rule 26-C (b) 3.** The 50-foot requirement when using a derail to provide blue signal protection for workmen on the short dead end track, known as the "Pit Track" within engine servicing and maintenance facility at Oroville, is **not** required subject to the following conditions:

1. When the length of locomotive and/or the position of the locomotive over the inspection pit will permit, the end of the locomotive to be protected must be at least 50 feet from the derail.

2. When the length of the locomotive and/or the position of the locomotive over the inspection pit does not permit the end of the locomotive to be 50 feet from the derail, the maximum distance possible must be maintained.

3. The derail being utilized to provide protection must be permanently installed on the pit track on the end of the track adjoining the turntable as close as possible to the edge of the turntable. Use of a portable derail is prohibited.

**Rule 541.** Westward SP trains and engines must contact train dispatcher for instructions to move Oroville Yard to MP 180.42.

## SPECIAL INSTRUCTIONS — WESTERN DIVISION SECOND SUBDIVISION

### Binney Jct.

#### SP Connection MP 180.42.

**Rule 550.** The hand-operated switch is east connected to main track, equipped with electric lock and protected by separate hand-operated derail located on turnout approximately 110 feet west of main track switch.

Instructions for operation of electric lock located in telephone box adjacent to main track switch. Electric lock switch must be operated before derail, otherwise electric lock will not release.

**Rule 541.** Eastward SP trains and engines at MP 180.42 must contact train dispatcher to obtain permission to operate electric lock and for instructions to move MP 180.42 to Oroville Yard.

### Marysville

**Rules 340-A and 541.** SN trains or engines must contact train dispatcher for permission to enter siding and for instructions to move Marysville to Cleveland or beyond.

**Rule 550.** Instructions for operating electric locks are posted in telephone booths adjacent thereto.

Permission must be obtained from train dispatcher before electric locks can be released and he must be notified after movement is completed and electric lock has been locked.

Inside crossover switch on siding and hand-throw tandem derails on east end of tracks 1 and 2 are not electrically-locked and must NOT be operated before obtaining electric lock D-26.

**Rule 104-A.** SN connection switch on siding must be locked for siding when not in use. All movements on siding must be made at yard speed.

### Sankey

#### Rules 509, 545 and 546.

### Sacramento Northern:

**Westward** — Inoperative distant semaphore signal located 3385 feet east of absolute signal.

Absolute Signal is a two-unit signal. Upper unit governs movements to UP main track. Lower unit governs movements on SN to Sankey.

**Eastward** — Absolute Signal governs movements to SN Rio Linda Branch.

### Second Subdivision

**Westward** — Absolute Signal is a two-unit signal. Upper unit governs movements on UP main track. Lower unit governs movements to SN Rio Linda Branch.

Dual control switches provide entrance to SN main track. Instructions for operating Dual Control switches by hand are posted in telephone booth adjacent to the switches.

### Haggin

**Rule 541.** Eastward SN trains and engines at Haggin must contact train dispatcher for instructions to move Haggin to Sankey or beyond.

**Rule 104-A.** In order to operate toward SP Transfer at East Haggin obtain permission from Dispatcher to operate derail. After derail is removed, aspect per Rule 287 can be displayed. After movement to SP transfer is completed, restore derail to derauling position and notify dispatcher.

### R St.

**Rule 104-A.** Normal position of switch at tail of wye "R Street Line" is lined for west leg of wye.

### South Sacramento

**Rule 103C.** When setting out on or switching any tracks at South Sacramento yard, it must be determined that a sufficient number of hand brakes, not less than three (3), have been set on the extreme east cars on the track.

Carmen, when bleeding a cut of cars, will leave air in the east five (5) cars until it is ascertained that a sufficient number of hand brakes, not less than three (3), have been set to secure these cars, and must notify yardmaster.

**Rule 547.** Flashing red aspect displayed by indicator on signal mast beneath Sutterville overpass, authorizes switching movements between absolute signals at east and west ends of train yard without contacting train dispatcher. All movements so authorized must be made at yard speed. It will not be necessary to wait five minutes before entering main track after opening non-locked switches in this block when flashing red aspect is displayed on the indicator.

When the flashing red aspect is extinguished it will terminate the authority and main track must be cleared as promptly as possible. If unable to clear the main track within five minutes, the train dispatcher must be contacted.

Except when Signal Aspect per Rule 288 is displayed, permission may be granted by yardmaster upon authority from train dispatcher to use main track between the points named above. When such authority has been obtained, a Form U is not required and that portion of Rule 547 is modified accordingly.

**Rules 545-546-A.** Dual control power operated switch to safety track at clear point east end siding. Switch to safety track operates in conjunction with power operated main track switch. When east switch is hand operated, power operated switch to safety track must also be hand operated. It is permissible for a yard engine to make an eastward move over it by signal indication, then, without reaching main track move westward without placing the switch to safety track in hand-throw position. However, if there are a series of such moves, the switch to safety track must be placed in hand-throw position to avoid hazard of train dispatcher changing lineup during the switching operations.

**Rules 545-547.** At South Sacramento authority to place power switch at east end in hand-throw position will carry with it authority to switch in the block between east switch South Sacramento and eastward absolute signal at R Street and at west end authority to switch in the block between west switch South Sacramento and Pollock. This means that two yard engines may be granted authority to switch over power switches at opposite ends of South Sacramento at the same time but, only the yard engine which has specific authority from the train dispatcher to do so may use the main track block between east and west switches. The foregoing not in conflict with instructions under Rule 547.

It will not be necessary for train dispatcher to record switching authority in connection with permission to use these power switches except when authority includes the main track block between east and west switches.

A yard conductor may permit road crews to use his switching authority for moves, such as engine to or from train, etc., or other switch crews crossing over, but must insure that there is no hazard by reason of his own switching operations.

**Rule 550.** Campbell Soup Co. track. West crossover switches both electrically-locked. After lock is released main track switch must be opened before inside switch can be opened and inside switch must be closed before main track switch can be closed.

### Laguna Creek

**Rules 103C-104A.** Four wheel chocks are provided to block spotted cars. Each wheel chock is equipped with metal stand which clamps on the rail and displays a 10-inch circular metal disc painted yellow with black lettering: "CHOCKS."

Hayes No. 5 toad type derails installed to protect spotted cars on the right hand rail on both spurs are equipped with clamp-on rail stands displaying a 12" x 14" rectangular target painted blue with white lettering: "STOP — TANK CAR CONNECTED."

### Thornton

**Rule 14A.** Sound Whistle Signal 14.11 approaching MP 114, Thornton Cannery.

**Rule 103C.** An electrically-operated steel pedestrian bridge over cannery track is located about two car lengths west of Door No. 12. This bridge is controlled by electric switch pushbuttons inside a wall box, secured by switch lock, adjacent to bridge.

Before commencing switching on this track, crew must insure that bridge is in fully raised position. If bridge is in down position, press electric pushbutton marked "Raise" until bridge comes to rest in fully raised position.

### Stockton Yard

**Rule 104-A.** Switch leading to Tidewater Southern main track off No. 3 lead, just west of Bridge 90.4, normal position lined for Tidewater Southern.

Diverging switch between No. 1 and No. 2 leads at east end of Bridge 90.4, normal position toward No. 2 lead and trains entering No. 1 lead at this point must be sure switch lined back to normal position.

**Rule 545. Charter Way.** Westward signal is a two-unit signal and diverging route may be to either "B" lead or Track 1.

Normal position for dual control switch at Charter Way from B Lead to Santa Fe connection is for movement to Santa Fe. Upper unit of two unit dwarf signal governs movement from B Lead to main track and lower unit governs movement from B Lead to Santa Fe and will display aspect per Rule 288 to permit movement to Santa Fe. Dwarf signal on Santa Fe connection near Charter Way governs movement from Santa Fe to B Lead and will display aspect per Rule 288 for such movement. Power operated switch operates in tandem with main track switch to B Lead. When either of these switches or the switch from main track to No. 1 track is in hand throw, power is disconnected from the other switches in the circuit and other switches need not be placed in hand throw unless they must be thrown. See Rule 545.

**MP 90.85** Main track and inside crossover switches at west end of train yard, MP 90.85, are dual-control. When either switch is placed in hand-throw position the other switch is disconnected from power operation and it is then unnecessary to place it in hand-throw position.

Dwarf signals governing movement on No. 1 lead track over inside switch of power-operated crossover MP 90.85, are absolute signals controlled by the train dispatcher. When these signals display aspect per Rule 288, movement may be made over this switch without placing it in hand-throw position.

These signals may be set to display STOP per Rule 292 by the train dispatcher at any time. If these signals display STOP indication per Rule 292 and reason is not apparent, or if call light is lighted on signal house north of main track, contact train dispatcher promptly by telephone.

**Rule 547.** Flashing red indicator lights are located at MP 91.02 and at MP 91.88. When flashing, per Rule 288, these indicator lights authorize switching movements between absolute signals at MP 90.85 and Charter Way MP 92.7 without contacting Train Dispatcher. All movements so authorized must be made at yard speed. It will not be necessary to wait five minutes before entering main track after opening non electrically-locked switches in this block when flashing red aspect is displayed on the indicator.

When the flashing red aspect is extinguished, it will terminate the authority and main track must be cleared as promptly as possible. If unable to clear main track within five minutes, the Train Dispatcher must be contacted.

Except when Signal Aspect per Rule 288 is displayed, permission may be granted by yardmaster upon authority from train dispatcher to use main track between the points named above. When such authority has been obtained, a Form U is not required and that portion of Rule 547 is modified accordingly.

**Rule 887.** Westward trains, caboose hops and lite engines will be governed by signal indication entering Stockton Yard.

Trains heading in at Charter Way will call Yardmaster on phone at Charter Way for instructions unless instructions have been received by radio prior to reaching Charter Way.

Clear radio instruction from yardmaster may be acted upon in lieu of calling on phone or speaker. See Rule 40.

Eastward trains, caboose hops and light engines will be governed by signal indication entering Stockton Yard.

Eastward trains which head in at MP 90, call yardmaster on phone located near absolute signal for track instructions.

Eastward trains which head in at MP 90.85, call yardmaster on talk-back speaker for track instructions.

Clear radio instruction from yardmaster may be acted upon in lieu of calling on phone or speaker. See Rule 40.

Unless instructed by yardmaster, No. 4 lead will not be used for train movements.

**ATSF Conn:** Train and yard movements are prohibited with cars 61 feet or longer on track between UP main and ATSF.

**Weber Ave. Line.** Union Pacific, Santa Fe and Southern Pacific have joint operating rights over the Weber Ave. Line which extends from the switch on Santa Fe near Commerce St. to Weber Ave. Industries.

## SPECIAL INSTRUCTIONS — WESTERN DIVISION FIRST SUBDIVISION

### Army Supply Depot (Lathrop)

**Rule 104-A.** At west end, normal position of all switches in switching lead lined for switching lead. Do not exceed 10 MPH on switching lead or interchange trackage with Army Supply Depot.

Tracks 2 and 3 are to be used for setting out and picking up cars.

### Tracy (Lyoth)

**Rule 545.** Main track and inside crossover switches at Lyoth on east end Tracy siding are dual-control. When either switch is placed in hand-throw position the other switch is disconnected from power operation and it is then unnecessary to place it in hand-throw position.

Signals governing movement over inside dual-control switch are controlled by train dispatcher. When signals display aspect per Rule 288, movements may be made to or from SP interchange and engines may move over this switch without placing it in hand-throw position. If signals display STOP aspect per Rule 292 and reason is not apparent or if call light is lighted on adjacent telephone booth, train dispatcher must be contacted promptly.

## Trevarno

**Rule 550.** Drill track. Switch is electrically-locked and is protected by hand-throw derail. Derailed is not electrically-locked and must remain in derailing position until release of electrically-locked switch is obtained. Derailed actuates signals on main track when not in derailing position.

## Bridge 35.09 Alameda Creek

**Rule 14-C.** "W" Sign — Whistle board is placed approximately one-quarter mile in advance of bridge. Whistle signal as prescribed by Rule 14.16, a succession of short sounds, will be sounded approaching bridge.

## Niles Jct. (Also see San Jose Branch)

**Rule 550.** An electrically locked switch is at west end west leg of wye and an electrically locked switch point derail is located at clearance point.

## Fremont

**Rule 105B.** Train dispatcher must be notified when cars are left on siding Fremont. Train dispatcher's telephone located inside east end of station building.

When making delivery to SP at Shinn siding, cars must be placed with a clearance of not less than two car lengths from dwarf signal at east end of Shinn siding. Do not enter SP Main track.

Derailed located at clearance point at west end of Shinn siding.

When cars are placed on Shinn siding, towerman Niles Tower must be notified.

## Hayward

**Rules 103B and 271.** A lunar white marker light on 7-foot mast is located to the right of the siding at MP 20.15. Eastward trains moving on siding finding this lunar white marker light illuminated may proceed to east siding switch and be governed by signal indication displayed there. Eastward trains finding this marker light extinguished must stop before passing it and contact train dispatcher for instructions.

Train dispatcher's telephone is located in booth adjacent to marker light mast.

**Rules 103B and 509.** Eastward absolute signal located to right of main track at "A" Street, MP 20.1. Eastward trains moving on main track finding aspect displayed per Rule 292 will be governed by Rule 509.

## Permasco Car Skates

**Rule 103-C.** Located at Midway and Hearst as follows:

Midway-In phone booth at East Midway.

Hearst-In phone booth at West Hearst.

When setting cars out on these sidings, skates must be used. If cars already on siding, arrange to couple cars to be set out with the cars already there, resetting skates under outside pair of wheels of truck of first car on the down hill side. When coupling into car or cars on siding make coupling carefully and see skates removed before cars are pulled or pushed. When all cars are removed from siding replace the skates in the phone booths at East Midway and West Hearst.

In addition to the use of Permasco car skates, a sufficient number of hand brakes must be set. Cars must be coupled if practicable. Wheels must be further blocked if necessary to prevent their movement.

## Oakland

**Rules 80 and 93.** Before trains are authorized to move against the current of traffic between Clinton and Chestnut Jct., train dispatcher must first contact yardmaster Oakland yard advising him of such impending train movement. After yardmaster has informed train dispatcher yard engines have been notified and track to be used is clear, train movement against the current of traffic will be authorized as follows:

Westward: By signal indication per Rule 292-A at absolute signal Clinton.

Eastward: Verbal authority from yardmaster after he receives concurrence from train dispatcher, has notified yard engines and track to be used is clear.

Yard engines must move with the current of traffic when practicable, using crossovers to move to other track to perform work. Before fouling or using crossover or before moving against the current of traffic, conductor must receive information from yardmaster or train dispatcher that no opposing train will be encountered.

**Rule 103-B.** Radio communication is now available with Magnolia Tower. In no way will such communication change the authority of the yardmaster to control movement of trains in and out of Oakland Yard. The sole purpose of communication with Magnolia Tower is to prevent blocking of El Dorado Road and Ferro Street in the case of Eastbounds, and Oak Street to Filbert Street inclusive, in the case of Westbounds, when towerman is unable to give UP train the route across SP.

**Rule 104-D.** Spring switch located at end of double track Clinton normally lined for westward main track and may be trailed through eastward on eastward main track.

"S" Unit must be illuminated per Rule 292-A before spring switch is reversed. Trains or engines moving from eastward main track to westward main track or vice versa, must move beyond signal and receive proper signal indication for reverse movement. If authorized to pass this signal in STOP position, spring switch must be examined and points found to fit properly for movement desired.

**Rule 105.** Joint UP and SP drill track between Melrose and Elmhurst must not be used for meeting or passing trains.

**Rule 228-Z. Dimensional Shipments.** If train has car or cars of excessive dimensions, after determining that a high-wide message is on file authorizing movement and after notifying train dispatcher, yardmaster, yard or station forces will issue message Form T-5 on blue paper, with a copy of high-wide message attached, to conductor and engineer. A copy of Form T-5 and high-wide message must also be attached to waybill.

**Rule 540.** Train dispatcher must be notified when yard engines intend to enter T.C.S. on main track at Clinton and thereafter signal indications will govern.

Westward Absolute Signal east of switch, Clinton, is a single unit signal with "S" unit on mast. This signal will display aspects per Rule 292, 292-A and 288. All westward movements will be authorized by flashing red aspect per Rule 288.

## SPECIAL INSTRUCTIONS — WESTERN DIVISION BRANCHES

### Reno Branch

#### Rocky Mount No. 2, MP 31.57.

**Rule 103-C.** No derail, keep hand brakes set and do not leave cars west of first road crossing.

### Permasco Car Skates

**Rule 1107.** Permasco car skates must be used under locomotive at North Reno when it is left unattended. In addition hand brake must be set on each locomotive unit.

**Rule 103-C.** Permasco car skates must be used at Martin, Panther run-around, Cal-Gas and Petrolane on Sierra Pacific Spur.

When setting cars out on any of these tracks, see that skates are used. If cars already on siding, arrange to couple cars to be set out with the cars already there, resetting skates under outside pair of wheels of truck of first car on the down hill side. When coupling into car or cars on siding, make coupling carefully and see skates removed before cars are pulled or pushed.

In addition to the use of Permasco skates, a sufficient number of hand brakes must be set. Cars must be coupled if practicable. Wheels must be further blocked if necessary to prevent their movement.

#### Derauls on Main Track, MP 28.85, MP 30.7 and MP 31.67.

**Rule 104-A.** Derauls must remain in derailing position except when track is in use at point of derail and must be returned to derailing position as soon as movement has passed. Signs reading "Derail 200 feet" are located 200 feet in advance of each derail in both directions.

### Loyalton Branch

**Rule 104-A.** Split point derail installed about 210 feet east of chip track switch, Loyalton. Derail must be in derailing position except when main track is being used.

### San Jose Branch

#### Dimensional Shipments

**Rule 228-Z.** If train has car or cars of excessive dimensions, after determining that a high-wide message is on file authorizing movement and after notifying train dispatcher, yardmaster, yard or station forces will issue message Form T-5 on blue paper, with a copy of high-wide message attached, to conductor and engineer. A copy of Form T-5 and high-wide message must also be attached to waybill.

#### Niles Junction (Also see First Subdivision)

**Rule 103-B.** Eastward Automatic Signal Number 08 located MP Branch 0.8 just west of Morrison Canyon Road governs approach to absolute signal at Niles Jct. and may display aspects per Rules 281, 285 or 291.

Trains in excess of 4100 Ft. in length including caboose which find this signal displaying aspect per Rule 291 or Rule 285 must stop and contact train dispatcher for instructions so as to not block Morrison Canyon Road unnecessarily.

**Rule 540.** When aspect per Rule 283 is displayed on westward main track absolute signal, East Niles Junction, this will authorize movement from Niles Junction to Curtner.

Tail of wye switch hand operated; normally lined for east leg of wye. Trains or engines using west leg of wye must do so at yard speed and must not operate tail of wye switch or pass clearance point without permission of train dispatcher.

### Milpitas

**Rule 104-A.** Derail on east leg of wye located at clearance point. Derail on west leg of wye located 392 feet east of main track switch.

### Milpitas — Ford Plant

At the Ford plant there are electrically-locked derauls on Tracks F-1 and F-2, located 200 feet east of the east track entrance and 227 feet west of the west track entrance to the assembly building. The doors to the track entrances at each end of the building cannot be closed until the derauls are lined in derailing position and locked. Unless requested by the Ford Motor Co. cars must not be left on either track at either end of the building between the derauls and point of entrance to the building.

In addition, at the east end, not more than two cars may be left (while switching or otherwise) on either Tracks F-1 or F-2 between the diverging switch to these tracks and the derauls. If Ford Co. orders two cars left on either tracks F-1 or F-2 as above, the west car must be left as close to derail as safety permits to allow clearance on east end of these cars.

Hayes type derauls installed on Track F-4, 388 feet west of east switch to Track F-3 and on Track F-5, 238 feet west of entrance switch.

Gates, doors to buildings and derauls on both east and west ends of Ford plant are controlled and operated by Ford security police except that West Gate 11 will be operated by trainmen.

## SPECIAL INSTRUCTIONS — WESTERN DIVISION BRANCHES SACRAMENTO NORTHERN

### General

Applicable instructions appearing in Western District portion of this timetable will be observed on Sacramento Northern in addition to instructions appearing in Sacramento Northern section.

**Rule 10-H, first paragraph.** A metal banner at right of track displaying yellow indicates that trains must reduce speed over track to 10 miles per hour until rear of train has passed temporary resume speed signal unless otherwise directed by train order or bulletin. Such signal must be placed one-fourth (¼) mile before the location is reached where speed of trains must be reduced.

**Rule 17-C.** Headlights must be dimmed while moving within city limits.

**Rule 17-D.** Reverse movements over grade crossings must be protected per the provisions of this rule by engineer operating the oscillating white (or amber) light, reversing handle located inside the locomotive cab roof as necessary so that this light is displayed in the direction of movement prior to entering the crossing.

**Rule 18 — Modified.** Yard engines when making a continuous movement along city streets will not display the headlight at the rear by night. A red light or fusee must be displayed to the rear, and on the rear of the last car when cars are being handled.

It shall be the responsibility of the rear brakeman to see that a red light or fusee is continuously displayed at the rear until movement is completed.

When stop is made and train or yard engine is left standing in street, trainman will place lighted fusee in the street at rear of cut and when necessary for trainman to leave rear of cut to go ahead, one or more lighted fusees will be left to provide continuous protection at the rear end.

**Rule 21** of the Operating Department Rules is suspended.

**Rule 1118.6.** Air must be cut in and air brakes in operation on all yard cuts, and on trains within yard limits, when moving over and along city streets except when doing station work or yard switching.

See Public Grade Crossings.

### Chico Branch

#### Marysville

See Second Subdivision.

### Marysville — Yuba City

**Rule 301.** Automatic block signals between Marysville and Yuba City:

Two indication color light home signals located as follows:

Signal 190 feet west of junction switch opposite Marysville depot governs westward movements.

Signal 1397 feet east of Yuba City depot governs eastward movements.

Movement of trains and yard engines within home signal limits will be made in accordance with indication of signals subject to the following regulations:

Flashing white light located on pole about 100 feet east and across main line from Trainmen's Locker Room to apprise trains and yard engines of condition of route between home signals. When flashing, route is unoccupied.

Before proceeding from Yuba City depot to Marysville, member of crew shall press push button mounted on outside wall of Trainmen's Locker Room which holds route for eastward movements for a period of ten (10) minutes and causes flashing light to burn steadily. Train or yard engine may then proceed, being governed by indication of home signal.

### Colusa Jct.

Gates have been installed across main track West leg of wye (140179-069) and are equipped with switch locks. A member of crew must open and latch gates open when entering and must close and lock gates after train or engine has passed.

### Chico

On city streets, trains and engines must use caution where movements are made against current of vehicular traffic and must stop if necessary before crossing vehicular traffic lanes.

Trainmen are prohibited from riding on the side of engines and cars between MP 184.5 and MP 185.8 on the Esplanade at Chico.

A lighted red fusee must be placed at the rear of all westward movements on city streets in Chico.

**Rule 17-D.** Engines so equipped will display oscillating or revolving lights for all movements within Chico yard limits. Unless engine is displaying a flashing Strobe light on leading end which is mounted below top of hand rail, a lighted fusee will be displayed on leading end of engine when moving on city streets.

See also Public Grade Crossings.

### Woodland Branch

**Rules 109, 110.** A member of train crew must ride the rear platform of the caboose on all trains moving over Fremont Trestle, Bridge 10.24 W, to watch for fires or evidence of dragging equipment and must keep a lookout for signals from trackwalker or bridgemen.

### Holland Branch

Close clearance, sugar plant eaves, Clarksburg.

### Vacaville and Dozier Branches

**Rule 1117.** Eastward trains will make air brake test as prescribed in Rule 1117, Initial Terminal Road Train Air Brake Test, before entering Southern Pacific main track at Cannon.

East leg of Wye Vacaville Junction is out of service and cannot be used.

### Pittsburg Branch

**Rule 1117. Pittsburg** — Eastward trains will make air brake test as prescribed in Rule 1117, Initial Terminal Road Train Air Brake Test, at Pittsburg, before entering Santa Fe main track.

## Joint Track

(A) **Rule 701.** Sacramento Northern trains and engines use Santa Fe tracks between Stockton and Pittsburg.

Trainmen and Enginemen using Santa Fe tracks will be governed by Santa Fe Operating Department rules and must have copy of current Santa Fe Operating Department Book of Rules, copy of current Santa Fe Valley Division timetable, and Santa Fe switch key in their possession at all times while on duty on Santa Fe.

Bulletin books containing Santa Fe Valley Division TM bulletins governing train operations are maintained at the Trainmen and Enginemen's locker room at South Sacramento. Trainmen and enginemen and others concerned must consult the Santa Fe bulletins before departing on trains operating over Santa Fe tracks.

(B) **Rule 701.** Sacramento Northern trains and engines use Southern Pacific tracks between Cannon and 19th Street, Sacramento.

Sacramento Northern movements between Haggin and Westgate are made on Southern Pacific between 19th Street and Sacramento-Yolo Port RR connection.

At 19th Street and at Port RR connection stop clear of fouling point and contact SP yardmaster or herder for permission to enter SP tracks. Before entering SP at 19th Street, it must be known by observation that there is no movement closely approaching the track to be occupied.

Southern Pacific third rail between 19th and 23rd Streets, Sacramento, and east leg of wye between its connection with SP third rail and SN main track at 20th and B Streets will be used by SN crews to turn engines and cars. Permission of SP yardmaster or herder must be obtained before entering third rail.

Sacramento-Yolo Port and SN trackage between Southern Pacific main track and switch to Sacramento-Yolo Port trackage near Riske Lane is jointly used by SN and SP. All movements on this joint track will be governed by block signals whose indications supersede the superiority of trains. Indicators at entrance switches indicate track occupancy. When indicator shows block clear, switch may be reversed and movement started when yellow aspect is displayed by the signal. If indicator shows block occupied, switch must not be reversed until it is known that there is no opposing or conflicting movement. If, after switch has been reversed, signal displays stop indication, train or engine must wait five (5) minutes and then be preceded by flagman through joint track area. Speed in joint track area is restricted to 10 MPH.

Southern Pacific Railroad operates on that portion of Sacramento Northern Railroad Track from Soule Street to approximately 500' west of 15th Street, maximum operating speed 10 MPH.

The switches at Riske Lane, Soule Street, and 15th Street will be lined back for the Sacramento Northern main line, and locked with Southern Pacific switch locks.

Flag protection to rear is not required on joint track at Broderick, Westside or on Sacramento-Yolo Port RR connection. All movements must be made at yard speed not exceeding ten (10) MPH.

(C) Speed of trains handling loaded air dump cars on Southern Pacific is restricted to twenty-five (25) MPH.

(D) Sacramento Northern trains and engines use Southern Pacific tracks between Live Oak and Durham.

Hand operated switches equipped with electric locks located at SP MP 152.20 and SP MP 152.21. Live Oak, provide access to SP main track for movements between Live Oak and Durham. Signals governing movements to SP main track located in advance of junction switches.

Hand operated switch equipped with electric lock located at SP MP 178.2 Durham, provides access to SP main track for movements between Durham and Live Oak. Sign reading DO NOT FOUL MAIN TRACK WITHOUT DISPATCHER'S PERMISSION located in advance of junction switch.

Contact SP Train Dispatcher for permission to operate electric locks. Instructions for operation of electric locks located in telephone boxes adjacent to junction switches.

(E) Trainmen and Enginemen using Southern Pacific tracks will be governed by SP Co. Transportation Dept. Rules and Special Instructions and must have copy of Southern Pacific book of rules, current timetables with special instructions, and switch key in their possession while on duty on Southern Pacific.

Bulletin Books containing Southern Pacific Western division and Sacramento Division timetable bulletins are located at Westside, Sacramento Yard. Southern Pacific Sacramento Division timetable bulletins are located at Yuba City. These bulletins must be reviewed before operating over trackage of SPT Co.

(F) Sacramento River Drawbridge, MP 88.65, is a Train Order Office for westward Sacramento Northern trains to the Western Division, SPT Co.

Sacramento Northern trains originating Sacramento 19th and B Sts. or Sacramento-Yolo Port District connections to Western Division SPT Co. must obtain SP clearance at Sacramento River Drawbridge.

Sacramento Northern crews are to contact Operator by use of telephone at Drawbridge (Ext. 339) to receive orders.

(G) Sacramento Northern trains and engines use Second Subdivision tracks as follows:  
Between South Sacramento and Stockton yard.  
Between MP 138.2 and Marysville  
See instructions under "SECOND SUBDIVISION."

**Rule 17-C.** Headlight must be dimmed while moving over 9th St. Modesto. See Public Grade Crossings.

**Rule 21.** Suspended on Tidewater Southern.

## Stockton Yard

**Rule 739.** Arrival time at Stockton Yard will be determined by the actual time of arrival at Ortega. This time will be used for:

1. Reporting arrival to the train dispatcher.
2. Wheel reports.
3. Delay reports and final terminal delay.

## Escalon and Aurora

**Rule 103-B.** When leaving cars on main track or sidings at Escalon and Aurora, all private crossings must be left open. See Public Crossings.

## Aurora

In compliance with PUC Order, observe the following instructions governing use of Aurora Siding, Tidewater Southern MP 29.5.

Aurora Siding must not be used except as follows:

Emergency operations resulting from unforeseen circumstances such as equipment failure, unsafe track structure, derailments, or other events over which railroad has no control.

Running around more than six cars between 6:00 AM and 12 midnight for purpose of pulling rather than shoving to SP transfer.

Parking of train between 6:00 AM and 12 Midnight when Hours of Service have expired and crew was unable to leave train at another location without violation of Hours of Service. When necessary to leave train on siding, locomotive must be shut down. It should also be noted that train should not be left at Aurora Siding under these circumstances if conditions will permit leaving it elsewhere, and crews must plan in advance utilizing all information to avoid the necessity of terminating their train at Aurora Siding due to Hours of Service.

Air Brake Tests must not be conducted in the vicinity of Aurora Siding and when mechanical refrigeration cars are left on siding for any reason, the motors must be shut down.

Except for emergency operations as described above, Aurora Siding is not to be used between 12:01 AM and 6:00 AM.

**Rule 104-A.** Switch leading to SP transfer, Modesto, must be kept lined for transfer, except when using Lyng spur. Switches in joint M&ET-TS Yard, Modesto, must be kept locked and lined for lead tracks.

## Modesto

Tracks in Modesto between E Street and Tuolumne River Bridge and Joint yard are operated jointly with the M&ET Co. TS Trains and engines must not go beyond west end of Dry Creek Bridge on M&ET without authority.

## Rogers

**Rule 26.** P&G blue light mounted to the right of doors into building. Until this light is extinguished, locomotive or cars must not move through gate located about three car lengths from building.

## Chemurgic

Engines must not operate beyond Switch 833. Cars only may be shoved beyond this location.

**Rule 101-A.** Additional instructions concerning track conditions between McHenry and Turlock and on Chemurgic Branch will be covered by Superintendent's and/or Trainmaster's Notices posted at Modesto and Stockton Yard.

## SPECIAL INSTRUCTIONS — WESTERN DIVISION TIDEWATER SOUTHERN RAILWAY

Applicable instructions appearing in other Western District portions of this timetable will be observed on Tidewater Southern in addition to instructions appearing in Tidewater Southern section.

**APPENDIX I  
WESTERN DISTRICT — INTERLOCKING  
PLANTS AND RAILROAD CROSSINGS  
SALT LAKE CITY TO OAKLAND**

**D&RGW Rule 290.**

<b>Aspect</b>	<b>Name.</b>
Red over red over lunar, or red over lunar, or lunar.	Restricting

**Indication**

Proceed at restricted speed:

- (1) Within ABS to next signal governing in the same direction.
- (2) At interlocking outside ABS through interlocking limits.
- (3) Onto non-signaling track until entire train is through turnout.

**D&RGW Rule 508.** The absence of a light or white light displayed where a color or lunar light should be, on an ABS signal, must be regarded as the most restrictive indication that can be given by that signal.

The following signals may display lunar aspect: Signal 66A governs movements entering Roper Yard from north and west; Signal 66B governs movements entering spurs lined to south or eastbound track to Roper Yard; Signal 66B governs movements departing Roper Yard to north and west; Signal 72 governs westbound movements out of Roper Yard on the eastbound running track; Signal 74 governs movements west out of Saucer No. 2.

**MP 928.6 UP Crossing.** Interlocking. Automatic. (When using DRGW running tracks) WP Rules apply.

**MP 927.2 Pollard Jct.** Interlocking  
**Grant.**

Towerman on duty.  
WP Rules apply.

**MP 765.9 NN Crossing.** Interlocking. Remote-controlled. Rules 509 and 663 apply.

When using dual-control switch west end Shafter siding in hand-throw position, movement must be made in accordance with Rules 545 and 663.

Derail installed in NN connection at clearance point for Shafter siding. Connection switch and derail equipped with electric locks which normally are in release position. If lock fails to release when padlock is removed, follow instructions in phone booth nearby.

**EMERGENCY RELEASE INSTRUCTIONS:**

CONTACT TRAIN DISPATCHER BY TELEPHONE BEFORE OPERATING EMERGENCY RELEASE. WHEN INSTRUCTED BY TRAIN DISPATCHER OPERATE RELEASE AS FOLLOWS:

1. Actuate push button until *red* indicator lamp is illuminated.
2. Either immediately or after three minutes the *yellow* indicator lamp should be illuminated, signal may display proceed indication, and movement can be made in accordance with indication displayed.
3. Should signal fail to indicate proceed, the illuminated *yellow* indicator lamp indicates signals on conflicting routes display stop. Movement may be made in accordance with Rules 509.1a and 663.3.
4. Should *yellow* indicator lamp fail to illuminate, movement must be governed by Rules 509.1a and 663.2e.

**West Carlin MP 643.4.** See Special Instructions, Sixth Subdivision.

**MP 180.2 Binney Junction, SP Crossing.** Remote-controlled. Under control of SP train dispatcher.

When interlocking display STOP aspect and reason not apparent, contact SP train dispatcher.

SP dispatchers telephone and UP emergency release box located adjacent to crossing. Emergency release must be operated when instructed to do so by SP train dispatcher or when instructed by SP train dispatcher to flag through interlocking. If unable to contact SP train dispatcher and no trains can be seen or heard approaching, operate emergency release and observe Rule 663.

**EMERGENCY RELEASE INSTRUCTIONS:**

1. Actuate push button until *red* indicator lamp is illuminated.
2. Either immediately or after three (3) minutes and forty-five (45) seconds, the *yellow* indicator lamp should be illuminated and signal may display proceed indication. Movement may then be made in accordance with indication displayed.
3. Should signal fail to indicate proceed, the illuminated *yellow* indicator lamp indicates signals on intersecting route are at stop. Movement may then be made in accordance with Rule 663.3 without providing flag protection on intersecting rule.
4. Should *yellow* indicator lamp fail to illuminate, movement must be governed by Rule 663.2e.

**MP 152.5 Sankey, SN Crossing and Connection.**

**Rules 509 and 546 apply.** Westward absolute signal is a two-unit signal. Upper unit governs movements on UP main track. Lower unit governs movements to SN main track. See UP Special Instructions, Second Subdivision.

**MP 138.0 "R" Street, SP Crossing.** Interlocking. Remote-Controlled.

**Rules 509 and 546** also apply. Low dwarf signal bearing letter "A" located 80 feet east of "S" Street on west leg of wye governs movement from west leg of wye to main track only and does not apply to movements to California Builders Supply spur. When switch is lined for movement to California Builders Supply spur, this signal will display aspect per Rule 288.

Interlocking Home signals located 75 feet west and 200 feet east of SP Crossing west leg of wye govern movements over SP Crossing only. When these signals display aspect per Rule 288, movement may be made over SP Crossing at yard speed. If aspect per Rule 288 is not displayed, Rule 663 will apply and waiting time modified to three minutes.

Switches leading to California Builders Supply spur and CALPAK 15 spur are manually operated. These switches will be lined and locked normally for through movements on west leg of wye. Movements into and out of these spurs can be made without contacting train dispatcher.

Rule 670 is modified at this location to permit reverse movements to be made within interlocking limits provided a portion of switch cut or engine is between interlocking home signals.

That part of Rule 663.2e referring to waiting time, is modified to three minutes instead of ten minutes at this Crossing.

**MP 95.1 El Pinal, SP Crossing.** Interlocking. Remote-Controlled. Under control of SP train dispatcher.

When interlocking signals display STOP aspect and reason not apparent, contact SP train dispatcher.

SP dispatchers telephone and UP emergency release box located adjacent to crossing. Emergency release must be operated when instructed to do so by SP train dispatcher or when instructed by SP train dispatcher to flag through interlocking. If unable to contact SP train dispatcher and no trains can be seen or heard approaching, operate emergency release and observe Rule 663.

**EMERGENCY RELEASE INSTRUCTIONS:**

- A. Actuate push button until *red* indicator is illuminated.
- B. Either immediately or after six (6) minutes, the *yellow* indicator lamp should be illuminated and signal may display proceed indication. Movement may then be made in accordance with indication displayed.
- C. Should signal fail to indicate proceed, the illuminated *yellow* indicator lamp indicates signals on intersecting route are at STOP. Movement may then be made in accordance with Rule 663.3 without providing flag protection on intersecting route.
- D. Should *yellow* indicator lamp fail to illuminate, movement must be governed by Rule 663.2e.

**MP 93.8 Weber Avenue, SP Crossing.** Interlocking Remote-Controlled.

**Rule 509** also applies.

**EMERGENCY RELEASE INSTRUCTIONS:**

1. Contact train dispatcher for permission to operate emergency release.
2. After permission of train dispatcher is secured, push button until red indicator lamp is illuminated.
3. After release has operated, yellow indicator lamp should be illuminated and signal may display proceed indication. Movement may then be made in accordance with aspect displayed.
4. Should signal fail to indicate *proceed* after approximately four (4) minutes, the illumination of the yellow indicator lamp is an indication that signals on conflicting route display "STOP" and movement may be made in accordance with Rule 509.1a.
5. If yellow indicator lamp is *not* illuminated and signal does *not* indicate proceed, be governed by Rules 509.1a and 663.2e.
6. The part of Rule 663.2e referring to waiting time is modified to five (5) minutes at this crossing.

**MP 93.2 AT&SF Tower, AT&SF Crossing.** Interlocking. Towerman on duty.

**Rule 509** also applies. Limits of AT&SF Stockton Tower include that portion of main track and siding on the AT&SF to Fresno Street and signal indications will supersede the superiority of trains for both opposing and following movements on the same track. The movement of trains and engines in these limits will be supervised by the Tower who will issue instructions as may be required. The Tower must be advised in advance of any known condition that will delay the train or engine or prevent it from making usual speed.

Speed limit between Stockton Tower and Fresno Street 20 MPH.

Following fixed signals and indications are effective in above specified territory:

Red — Stop and communicate with Tower for instructions.

Flashing Red — Proceed prepared to stop short of train obstruction or switch not properly lined but not exceeding 20 MPH.

Red over Yellow — Same as Flashing Red.

Absolute signal governing movement from Hazelton Avenue Lead to UP Main track at MP 93.2 may display aspect per Rules 288 or 292. When aspect per Rule 288 is displayed, proceed to next governing signal.

Signal governing movement from Commerce Street and Fresno Street to AT&SF main track or siding may display aspect per Rules 288 or 292. When aspect per Rule 288 is displayed, this authorizes movement to AT&SF main track and siding.

When aspect per Rule 292 is displayed, crew must contact Tower for instructions.

Last governing signal on AT&SF main track and siding will authorize movement to UP main track. If aspect per Rule 292 is displayed, authority for movement may be obtained through towerman.

Dwarf signals at Center Street govern movement from AT&SF main track and siding to Commerce Street.

Following whistle signals will be observed:

From UP to AT&SF enroute Hazelton Avenue .....000—.

From UP to AT&SF enroute Commerce Street and beyond .....—0.

From AT&SF to UP main track and UP main track either direction .....—.

**MP 90.5 Ortega, Hunter Street Line, SP Crossing.** Interlocking. Automatic.

Movements over SP Crossing will be made in accordance with signal indication.

Westward interlocking signal is also absolute signal. RULE 663 applies.

Electric locks on UP main track switch to Hunter Street Line and derail located north side SP Crossing are under control of UP train dispatcher. Both switch and derail are equipped with spring device for trailing movements.

#### EMERGENCY RELEASE INSTRUCTIONS:

1. This Emergency Release must not be operated until applicable portion of instructions governing use of electric locks on main track switch or derail on Hunter Street Line have been followed.

2. *Push and Hold* the push button in this housing until *red* indicator light is illuminated. *Red* light indicates that the time release is in operation.

3. After time release has operated *yellow* indicator light should be illuminated. Upon display of the *yellow* indicator light release of the electric lock may be completed.

4. If electric lock indicated "unlocked," and *yellow* indicator is not illuminated, line switch or derail for movement and be governed by Rule 663.2e.

5. If *yellow* indicator light is illuminated and electric lock is not "unlocked" after six and one-half (6½) minutes advise dispatcher.

**MP 84.45, SP Crossing Lathrop.** Interlocking. Remote-Controlled. Under control SP Train dispatcher.

When interlocking signals display STOP aspect and reason not apparent, contact SP train dispatcher. When westward home interlocking displays STOP aspect, westward trains will stop to clear Lathrop highway crossing.

When switching is done on main track at West Lathrop or cross-over west end of Army Supply Depot track, SP train dispatcher must be notified by telephone, length of time to be used so signal lineup may be changed if necessary and must also be notified when switching is completed.

UP emergency release box located adjacent to crossing must be operated when instructed to do so by SP train dispatcher or when instructed by SP train dispatcher to flag through interlocking. If unable to contact SP train dispatcher and no trains can be seen or heard approaching, operate emergency release and observe Rule 663.

#### EMERGENCY RELEASE INSTRUCTIONS:

1. Actuate push button until *red* indicator lamp is illuminated.

2. Either immediately or after six (6) minutes, the *yellow* indicator lamp should be illuminated and signal may display proceed indication. Movement may then be made in accordance with indication displayed.

3. Should signal fail to indicate proceed, the illuminated *yellow* indicator lamp indicates signals on intersecting route are at stop. Movement may then be made in accordance with Rule 663.3 without providing flag protection on intersecting route.

4. Should *yellow* indicator lamp fail to illuminate, movement must be governed by Rule 663.2e.

**MP 74.05, SP Crossing Lyoth.** Interlocking. Automatic.

While doing work on tracks adjoining this Crossing, train or cars must be left outside of interlocking plant circuit governed by home signals in order to avoid delay to trains on opposing route.

Signals are approach clearing. If train or engine fails to reach home signal within eleven minutes after proceed aspect is displayed, train or engine must expect to find STOP aspect displayed. Secondary clearing circuits extending 500 feet in approach to home signals, must be occupied before signal may again display proceed aspect.

#### EMERGENCY RELEASE INSTRUCTIONS:

1. Push button until *red* indicator lamp is illuminated.

2. After time release has operated, *yellow* indicator lamp should be illuminated and signal may indicate proceed indication. Movement may then be made in accordance with aspect displayed.

3. Should signal fail to indicate proceed, after approximately five minutes, the illumination of the *yellow* indicator lamp is an indication that signals on conflicting route indicate "Stop" and movement may be made in accordance with Rule 663.3

4. If *yellow* indicator lamp is not illuminated and signal does not indicate proceed, movement may be made in accordance with Rule 663.2e.

**MP 42.7 and MP 42.97 Radum, SP Crossing.** Automatic Interlocking.

In order to avoid delay to trains on opposing route while doing work at Radum, train must be left outside of interlocking plant circuit governed by home signals.

#### EMERGENCY RELEASE INSTRUCTIONS:

A. Push button until RED indicator is illuminated.

B. Either immediately or after 80 seconds, the *yellow* indicator lamp should be illuminated and signal may display proceed indication. Movement may then be made in accordance with indication displayed.

C. Should signal fail to indicate proceed, the illuminated *yellow* indicator lamp indicates signals on intersecting routes are at stop. Movement may then be made in accordance with Rule 663.3 without providing flag protection on intersecting routes.

D. Should *yellow* indicator lamp fail to illuminate, movement must be governed by Rule 663.2e. Waiting time is modified to five minutes instead of ten minutes at this crossing.

**MP 30.3 Niles Tower, SP Crossing.** Interlocking. Towerman on duty.

**Rule 670.** Reverse movements may be made within interlocking limits without obtaining permission from the towerman provided a portion of the train or engine is between interlocking home signals.

**MP 13.7 Elmhurst, SP Crossing.** Interlocking.

**Automatic.** Approach clears for movements on SP. For UP route, UP Train Dispatcher must line the route in order for signal to approach clear.

**Rule 509** also applies.

#### EMERGENCY RELEASE INSTRUCTIONS:

1. Contact train dispatcher by telephone before operating release.

2. When instructed by train dispatcher operate release as follows.

A. Rotate handle to right (clockwise) as far as possible and hold in that position three (3) seconds or until *red* indicator lamp is illuminated.

B. Release handle and allow two (2) minutes for mechanism to run down.

C. Either immediately, or after two (2) minutes, the *yellow* indicator lamp should be illuminated and signal may display proceed indication. Movement may then be made in accordance with indication displayed.

D. Should signal fail to indicate proceed, the illuminated *yellow* indicator lamp indicates signals on conflicting route display stop. Movement may be made in accordance with Rule 509.1a and 663.3.

E. Should *yellow* indicator light fail to illuminate, movement must be governed by rules 509.1a and 663.2e. That part of rule 663.2e referring to waiting time as modified to five (5) minutes at this crossing.

**MP 10.6 and MP 10.7 Melrose, SP Crossings.** Interlocking. Remote-Controlled.

#### EMERGENCY RELEASE INSTRUCTIONS:

CONTACT UP DISPATCHER BY TELEPHONE BEFORE OPERATING RELEASE.

If instructed by dispatcher, or if dispatcher cannot be contacted, operate emergency release as follows:

1. Push button until *red* indicator is illuminated.

2. After time release has operated, *yellow* indicator lamp should be illuminated and signal should display proceed indication. Movement may then be made in accordance with aspect displayed.

3. Should signal fail to indicate proceed, after approximately three (3) minutes, the illumination of the *yellow* indicator lamp is an indication that signals on conflicting route display STOP and movement may be made on hand signal given by member of the crew stationed at the crossing and in accordance with Rule 663.3.

Should signal fail to indicate proceed and *yellow* indicator lamp is not illuminated, train may proceed after protection has been established at the interlocking in accordance with Rule 663.2e.

The part of Rule 663.2e, referring to waiting time, is modified to five minutes instead of ten minutes at this Crossing.

**MP 7.2 SP Crossing. Both Main Tracks.** No Interlocking.

Protected by manually-operated gates. When SP engines or cars are using SP track, gates will be across both UP tracks and indicate STOP to movement on UP in either direction. Trains must approach under control and not proceed over this Crossing unless it is known to be clear.

SP crews desiring to cross UP main tracks at this point must contact UP train dispatcher for permission prior to making the move.

Before giving permission, UP Dispatcher will protect the move as follows:

1. Place Westward Signal at Clinton at stop and place plug in appropriate jack on block time board.

2. Check on eastward trains or engines with Oakland Yardmaster.

3. Make entry in block time book.

After SP crew has reported movements over UP main tracks complete plug is to be removed, and entry in block time book closed out.

**MP 5.8-SP Crossing and MP 5.9-Chestnut Junction, Magnolia Tower.** Interlocking. Towerman on duty.

Eastward: Two-unit home signal 490 feet west of crossing. Upper unit governs movement to eastward main track; lower unit to westward main track.

Westward: Two-unit home signal on westward main track 700 feet east of crossing; upper unit governs movement to UP yard; lower unit to OT interchange. Color-light dwarf signal 490 feet east of crossing governs movement from eastward main track to UP yard.

Eastward whistle signals:

East yard to eastward main track, —.

to westward main track, —o—.

#### San Francisco

I. Interlocking in service on the SP and the AT&SF crossing at 25th and Illinois Streets, San Francisco:

Westward home signal is located 70 feet east of crossing.

Eastward home signal is located 25 feet west of Third Street.

Instructions for operation of interlocking posted in box on each home signal must read as follows:

#### 25th and Illinois Interlocking Instructions for Union Pacific Crews

Each movement into the interlocking must be made as provided in these instructions, even though train or engine may have vacated track between interlocking signals only momentarily.

1. Normal aspect of home signals red (Stop).

2. To clear signal for movement through plant, train or engine must be standing within 30 feet of home signal, then operate push button until lamp is illuminated.

3. After one minute, home signal should display proceed indication.

4. If signal fails to indicate proceed, member of crew must proceed to railroad crossings, and if no conflicting movement is seen or heard approaching or using the crossing, move train or engine into interlocking, STOPPING CLEAR OF CONFLICTING TRACKS. (Eastward trains will stop at west curb of Third Street.) Wait one minute, then train or engine may proceed at yard speed upon receiving hand signal from crew member at the crossings, except that eastward trains must also have green traffic signal to proceed across Third Street or provide flag protection while moving over the street crossing.

Switching movements may be made in either direction within interlocking limits provided train or engine does not vacate the track between interlocking signals.

UP crews crossing UP Lead track, when using Sugarhouse lead Track 1-025 or when entering J. D. Drayage Spur 1-611 or 612, will be governed by SP-AT&SF emergency instructions in the event signals do not display proceed indication. SP-AT&SF emergency instructions are posted in box on end of signal housing at crossing.

Eastward movements from Spur 0-592, formerly Ladies Choice spur, will be governed by home signal located 25 feet west of Third Street.

Push button and indicator lamp located in box across from San Francisco yard office now in service.

Push button will actuate westward home signal at 25th and Illinois Interlocker.

The Following instructions are posted in the box:

1. When westward movement is to be made through interlocker, actuate push button. After push button is actuated, indicator lamp will display a steady yellow light.
2. If there are no conflicting movements through the interlocker after approximately 60 seconds, the indicator lamp will display a flashing yellow light. This will indicate that the Westward home signal at the interlocker is displaying a proceed indication.
3. The westward home signal at the interlocker will display a proceed indication for approximately 6 minutes. If the signal has not been accepted before the expiration of this time, the signal will return to the stop position. It will then be necessary to reactivate push button to complete movement.

The push button across from the yard office is in addition to the push button located at the crossing.

When the yard office push button is actuated and the westward home signal at the interlocker displays a proceed indication, it will not be necessary to stop and actuate the push button at the crossing.

II. The UP track crosses over Southern Pacific tracks at Ninth and Division Streets, San Francisco.

All trains, locomotives, and cars shall come to a stop before proceeding across said crossing and shall not thereafter proceed until it has been ascertained that no trains, locomotives or cars are approaching from either direction upon the conflicting route within a distance and at a speed which will in any way render them liable to conflict with the movement about to be made over the crossing.

Southern Pacific Company shall have precedence in the use of the crossing.

III. Southern Pacific crossings of UP lead 941 and spur 931 on McKinnon Avenue, 200 feet southeast of east curb of Barneveld Ave., San Francisco.

In making movements in either direction on either track 941 or spur 931, STOP must be made at least fifty (50) feet from nearest rail of Southern Pacific track, and thereafter before proceeding, make sure no trains, engines or cars are approaching from either direction on Southern Pacific track.

Southern Pacific Company shall have the precedence in the use of the crossing.

IV. The following will govern operations over track crossing where Southern Pacific spur serving Eaton and Smith crosses UP work lead in Illinois Street near 25th Street, San Francisco.

In the use of the crossing, all engines, cars, or trains of the Southern Pacific company will come to a stop before proceeding across said crossing and shall not thereafter proceed until it has been ascertained that no engines, cars, or trains are approaching from either direction upon the conflicting route within a distance and at a speed which will in any way render them liable to conflict with the movement about to be made over the crossing.

All engines, cars or trains of the UP shall approach the crossing at a speed from which a stop can be made before fouling the crossing in the event that the crossing is occupied or about to be occupied by engines, cars, or trains on the conflicting route.

All engines, cars or trains of the UP shall take precedence in the use of the crossing.

V. Track in Illinois Street, crossing Marin Street and joint SP-AT&SF-UP track to serve the Port of San Francisco at the Army Street Terminal.

Signs reading — STOP — FLAG — RAIL AND HIGHWAY CROSSING are located as follows:

1. Adjacent to turnout in Illinois Street for crews working across the joint SP—AT&SF—UP track in Illinois Street and across Marin Street and into the Port of San Francisco trackage between Marin Street and Islais Creek.
2. Adjacent to Port of San Francisco gate for crews leaving the Port trackage and crossing the joint SP—AT&SF—UP track in Illinois Street.

Rail movements on joint trackage in Illinois Street may be expected to be approaching this track crossing at 6 MPH and shall have precedence in the use of the crossing.

#### San Jose Branch

**MP 19.6 Valbrick, SP Crossing.** No Interlocking. Stop and flag.

**MP 20.4 Willow Glen, SP Crossing.** Automatic Interlocking.

Home signals 225 feet east and west of Crossing. No approach signals.

All trains must come to STOP at home signals, and a member of crew go to Crossing and carefully follow instructions pasted inside of derail lock box at Crossing before proceeding over Crossing. If unable to get proceed signal, comply with Rule 663.

Instructions for movement over Crossing.

When lock door is open and block indicators are clear, electric lock will indicate unlock. Move electric lock lever from right hand position to left hand position, switch stand for derails can then be operated reverse, then return electric lock lever to right hand position. Signal will indicate proceed. When move is complete, move electric lock lever to left hand position, place switch in normal position and return electric lock lever to right hand position, close and lock door.

Electric locks indicate *locked* when either block indicators are at STOP. If after waiting five minutes and no SP trains are approaching, push button on right hand side of lock until lamp lights, then release. Lock will show unlocked after about four minutes. Move can then be made as above.

If line up is made and not used, push button on right hand side of lock to place UP signals at STOP and return lock and switch stand to normal as above.

Emergency release is for use only in case of mechanical failure, and if ever necessary to use notify SP yardmaster at once.

#### MP 22.3 West San Jose, SP Crossing. No Interlocking.

Protection by Stop Boards. All trains, engines and cars shall come to a STOP before proceeding across this Crossing and shall not thereafter proceed until it has been ascertained that no trains, engines or cars are approaching from either direction upon the conflicting route within a distance and at a speed which will in any way render them liable to conflict with the movement about to be made over the Crossing.

Southern Pacific Company shall have precedence in the use of the crossing.

#### Joint SP-UP Operation South 7th Street, San Jose.

The following will govern operations over crossing of UP switching lead (19031-007) and UP-SP joint Drill Track (19031-360) at South Seventh Street, San Jose:

1. In the use of this crossing, movements on the UP-SP joint Drill Track shall have precedence at all times.
2. Movements on the UP switching lead and on UP-SP joint Drill Track will stop at a distance of not less than ten (10) feet or more than fifty (50) feet before reaching crossing.
3. After stop has been made, if any movement is approaching on the conflicting route, movement will not be made over the crossing until movement on conflicting route has come to a stop.

#### SN-Chico Branch

**SP Crossing MP 137.08 Yuba City.** Stop and flag crossing unless proceed signal is received from flagman at the crossing.

#### Yuba City, MP 137.5.

The "B" lead, track 99, crosses the main track at grade on the east side of Bridge and Plumas Streets. Movements on "B" lead, track 99, will have priority in use of the crossing and trains and yard engines on the main track will approach the crossing prepared to stop if the crossing is occupied or a conflicting movement is approaching the crossing on the intersecting track.

**SP Crossing MP 182.02 Stirling Jct.** Stop. Proceed if crossing clear and there are no movements approaching on SP.

#### SN-Rio Linda Branch

#### MP 109.17, Sankey, WP Crossing and Connection.

See, SPECIAL INSTRUCTIONS — SECOND SUBDIVISION.

#### SN Woodland Branch

#### MP 1.55 Mikon, SP Crossing, Interlocking, Automatic.

Home signals located 500 feet east and west of crossing.

Inoperative fixed yellow signal arms located 2,000 feet from home signals.

Speed of trains shall not exceed fifteen (15) MPH between approach signals and home signals.

All trains, engines and cars must be brought to a stop before passing home signals at Southern Pacific crossing at Mikon and wait sixty (60) seconds before proceeding.

**Clockwork Time Release:** When trains are stopped by signals governing the use of automatic interlocking, flagman must be sent to crossing to operate clockwork time release located in box at the crossing locked with switch lock.

Release must not be operated when trains are within interlocking limits as defined by interlocking home signals, or seen or heard approaching on intersecting tracks.

Instructions for operating time release are posted in time release box at crossing and are as follows:

1. Rotate time release handle (clockwise) as far as possible, and hold in that position for approximately three seconds; then release handle.
2. After time interval of 4'30" red light in time release box should be displayed; indicating time release has completed timing function.
3. If home signal does not indicate proceed, and red indicator light in time release box is displayed, train may proceed over crossing, complying with Rule 663.2d. Note: Red indicator light at Mikon Crossing in lieu of "yellow" indicator light referred to in Rule 663.2d.
4. If home signal does not display proceed indication and red indicator light in time release box is not displayed after time release has completed movement; train may proceed across crossing, complying with Rule 663.2e.

#### SN Holland Branch

#### Bascule Bridge, Interlocking:

Bascule type drawbridge at MP 90.66 west end of Westgate, Sacramento Yard. This is a combination rail and highway bridge. Normal position of lift span is closed and locked for train movements and vehicular traffic.

Automatic interlocking governs movements on the bridge:

Two indication color light interlocking home signals displaying red and green aspects located 522 feet west of the bridge and 524 feet east of the bridge. APPROACH LIGHTED.

Approach circuits extend 2635 feet west and 1201 feet east of bridge.

All movements approaching and passing over the bridge will be made at yard speed, not exceeding ten (10) MPH.

If automatic interlocking home signal does not display a proceed indication, train or engine must be brought to a stop. Before passing home signal at Stop, the following regulations must be observed:

(1) Member of the crew will inform the Lockmaster or his Assistant that signal is at Stop and movement will be made under flag protection. (Applies only when Lockmaster or his Assistant is on duty).

(2) A member of the crew will examine the rail locks at the west end of the lift span of the bridge to determine that the locks are in normal position with the bridge in proper surface and alignment for rail movement.

(3) Unless Lockmaster or his Assistant informs the crew that bridge is about to be raised, train or engine may proceed with caution on signal of member of crew acting as flagman.

Release mechanism adjacent to signal relay case at east end of the bridge and rail locks at west end of the lift span MUST NOT be operated by trainmen or enginemen.

#### SN Pittsburg Branch

**ATSF Crossing MP 48.06 Pittsburg.** At a point 360 feet east from the curb line of Columbia St. SN crosses ATSF Lead. All movements on SN, ATSF and US Steel must stop not less than ten (10) feet nor more than fifty (50) feet from the nearest rail of the crossing and proceed only after a member of crew has gone to the crossing and determined that it is safe to do so.

**ATSF Crossing east of Harbor St., MP 47.39 Pittsburg,** is protected by "STOP" boards. All movements must come to a stop at the "STOP" boards and be preceded over crossing by a crew member who must ascertain it is safe to cross. ATSF has preference at this crossing.

**MP 46.24 Pittsburg.** A gate is in place on the AT&SF track which crosses the SN main track at MP 46.24. The gate is equipped with a Santa Fe switch lock and a switch lamp is mounted at the top of the mast supporting the gate.

Normal position for the gate is locked across the AT&SF track. All movements on the AT&SF will be brought to a stop prior to reaching the gate which is not to be unlocked or its position changed until it can be seen no movements are closely approaching on the SN. As soon as movement on AT&SF has been completed, gate is to be restored to its normal position and locked.

SN trains or engines shall approach this crossing at not exceeding 10 MPH, prepared to stop. One long blast of engine whistle per Rule 14.12 shall be sounded by SN train or engine when approaching this crossing. Distance signs are located 1000 feet from crossing.

#### Tidewater Southern

**M&ET Crossing 9th and B Streets, Modesto.** Trains and engines of M&ET shall be brought to a stop and crew shall ascertain that no conflicting movement is being made or about to be made before fouling this crossing. TS shall have precedence over M&ET in the event of simultaneous arrival at the crossing.

#### MP 32.7 — SP Crossing — Remote Controlled

Remote controlled interlocking signals are located each side of crossing and are under the control of the Southern Pacific Train Dispatcher.

Approach circuits 500 ft. in advance of interlocking signals indicate to the Southern Pacific Train Dispatcher the approach of a Tidewater Southern train.

Approach signals displaying aspect per Rule 285, located 1432 feet east and 890 feet west of home signal. Proceed from approach signals complying with Rule 285 and proceed through crossing upon proper signal indication at home signal. Diesel engine throttle must be placed in off position while locomotive is moving over crossing frog.

If signals fail to indicate proceed after a reasonable time, a member of the train crew must contact the Southern Pacific Train Dispatcher by telephone located at the crossing.

Emergency time release box is located adjacent to the crossing. The box is marked T.S. Ry. and locked with a switch padlock. Instructions for the operation of the emergency release are posted in the box.

The emergency release must only be operated when instructed to do so by the Southern Pacific dispatcher or if conditions are such that the Southern Pacific dispatcher cannot be contacted within ten minutes. The release may be operated only after it has been determined that no trains can be seen or heard approaching on the SP tracks. Rule 663 will govern after the emergency release has been operated.

Any defect in connection with this interlocker must be reported immediately to the Southern Pacific Train Dispatcher that he may notify signal maintainer. SP telephone line circuit switch is located inside the telephone booth above the door.

Operators of motor cars must stop at Southern Pacific crossing and when there is more than one man on the car the crossing will be flagged. Operator must know there are no Southern Pacific trains approaching before going over crossing.

## APPENDIX 2. WESTERN DISTRICT — PUBLIC CROSSINGS

**General.** When stopping or stopped near a highway or street crossing equipped with crossing gates, movement must not be made into such crossing until crossing gates are in down position.

#### Oroville Yard, Adelaide Spur

Approach circuits for the flashing light signals protecting the Louisiana Pacific Crossing No. 4-203.9c on the Adelaide Spur have been shortened to 440 feet either side of crossing. All movements approaching this crossing must not exceed 10 MPH.

#### Sacramento

**47th Ave. X-ing 4-133.9.** Stop and flag. Applies to Drill Track only.

**Fifth and R Sts. X-ing 4-139.15C.** Movement into, or over, crossing must be preceded by flagman on the ground.

**East leg of wye 19th St. near "Q" St. Stop and flag**

#### Stockton (Belt Line)

**Washington St. X-ing 4-94.25C and Lincoln St. X-ing 4-94.45C.** Amber lights on signal cases adjacent to Washington and Lincoln Sts. When lighted, indicates track circuit controlling crossing signals is occupied. When flashing, they indicate that crossing protection has been in operation for the required twenty seconds. Stop movement before entering crossing and after amber light shows steady light.

When amber light flashes, movement may be made across crossing in accordance with traffic conditions. About twenty seconds occupancy of track circuit as evidenced by steady amber light is required before flashing aspect of amber light will be displayed. If amber lights inoperative, crossing must be flagged.

#### Ayala Spur

Private Crossing for Banta-Carbona Irrigation District located 440 feet from the main line switch. This crossing is not to be blocked at any time. Phone booth just east of this crossing and when required to get permission to re-enter the main track, trains will stop clear of this crossing until a through move to the main line can be made without blocking the crossing.

#### Union City Industrial Park

**Pacific St. X-ing 4-26.92C. (U.S. Cold Stge).** Stop and flag. Place minimum of two fuses on each side of crossing prior to entering.

**Atlantic St. X-ing 4-26.13C. (Rylock).** Stop and flag.

**Central Ave. X-ing 4-26.20C.** Stop and flag. Place minimum of two fuses on each side of crossing prior to entering.

#### Carpenter

**Whipple Rd. X-ing 4-25.6.** Whipple Rd. must not be blocked while setting out, picking up or switching except while actually making a necessary move over the crossing.

#### Carpenter Industrial Park

**San Clemente St. X-ing 4-26.53C.** Until automatic crossing protection is in service stop and provide flag protection before entering crossing.

**Zephyr St. X-ing 4-26.54C.** Stop and flag. Place minimum of two fuses on each side of crossing prior to entering.

**Zephyr St., X-ing 4-26.93C.** Same as above.

**Huntwood Ave. X-ing 4-26.42C.** Same as above.

**San Luis Obispo Ave. X-ing 4-27.35C.** Stop and Flag.

**(Michelin Tire Spur)**

**Whipple Rd. X-ing 4-26.03C.** Stop and flag.

**(Drill from Davis Wire)**

#### Hayward

**"A" and "B" Sts. X-ings 4-20.2 and 4-20.3.** Trains doing switching will leave train outside of track circuits operating crossing bells at "A" and "B" Sts. and will use whistle and bell only when necessary to avoid accident. Westward trains or engines departing runaround track do not exceed 3 MPH and make certain crossing gates are down before entering "B" St.

#### Estudillo

**139th Ave. (Spur) X-ing 4-16.18C.** Stop and flag.

#### Oakland

**Walton Spur, X-ing 4-12.7C and Gerber Spur, X-ing 4-13.16C. San Leandro St.** Movements must be brought to full stop. If flashing light signals are not operating, crossings must be flagged by a member of the crew.

**75th Ave. and UP-SP Drill Track, X-ing.** Drill track approach circuits to automatic gates extend 400 feet west and 350 feet east of the crossing. Occupancy of the approaches for more than one minute without entering crossing will permit gates to raise. Flashing white indicator light on mast north side of drill track indicates gates are down. Crossing must not be entered until flashing white light is displayed. If flashing light not displayed and gates not down, crossing must be flagged.

**Seminary Ave., X-ing 4-11.3 and 66th Ave. X-ing 4-11.6.** Must be cut if blocked more than five minutes.

**San Leandro St., Drill 2, X-ing 4-10.90C.** Engines moving on Drill 2 at San Leandro Blvd. be governed by the following: When amber light on top of instrument case is illuminated it indicates track circuit has been actuated. When it flashes, it indicates that the flashing light signals have been in operation for twenty (20) or more seconds, and movement may proceed in accordance with traffic conditions. If amber light is inoperative, stop clear of crossing for twenty seconds and flag across.

**Montgomery Ward Spurs X-ing 4-9.4 (29th Ave.) and X-ing 4-9.4C (East 12th St.)** Movements must be brought to full stop. If flashing light signals are not operating, crossings must be flagged by a member of the crew.

**Broadway St. X-ing 4-6.6.** Crossing must not be blocked. Movements governed by vehicular traffic signals. Trains and engines must approach expecting to find signals at stop. Movement may proceed on green traffic signal without stopping. Lunar white light is located on near right-hand traffic light mast. When lighted, it indicates track circuit control is effective. Eastward trains and engines, if stopped or delayed between Washington and Broadway Sts., and Westward trains and engines, if stopped or delayed be-

tween Webster and Broadway Sts., in excess of one minute and find traffic signals displaying red, must stop within ten (10) feet of curb line of Broadway St. and wait for green traffic signal. Should traffic signal fail to display green and lunar white marker is not lighted, flag protection over crossing must be provided. Occupancy of intersection by a train or engine will cause signals governing vehicular traffic to display red. When traffic signals are not lighted, flag protection over crossing must be provided. After having crossed Broadway St., trains or engines must clear the circuits as soon as possible.

**Key Pipe and Supply Co. spur, Fifth St., Seventh & Union Sts.** Control of vehicular traffic signals at Seventh and Union Sts. is initiated by operation of push button instrument case located on the opposite side of track from Union Street. Crew members of engine desiring to move from Fifth St. to Key Pipe and Supply must operate push button when engine is ready to depart from Fifth St. Flashing light signals at Fifth and Union Sts. will start when control of vehicular traffic signal has been initiated. This may require forty-five seconds between operation of push button and starting of flashing light signals. Twenty seconds after flashing light signals start, a lunar white marker will be illuminated authorizing movement to proceed. A second lunar white marker is installed on the line-pole under the freeway underpass. If these markers are not illuminated, engine must approach the intersection of Seventh and Union Sts. prepared to stop in accordance with vehicular traffic signal indication.

**El Dorado Road X-ing 4-5.4.** All trains and engines must see that flashers are operating before occupying crossing.

**Ferro St., X-ing 4-5.16.** All trains or engines must see that crossing gates are down before entering crossing.

#### San Francisco

**Ninth and Division Sts. X-ing 4L-0.3.** Stop and flag.

**Seventeenth and De Haro Sts. X-ing 4L-0.7.** Stop and flag.

**Third St. at 25th St. X-ing 4L-1.7C.** City traffic signals are connected with UP track circuits. Rail movements will be governed by traffic signals which will display a green "X" as proceed indication. It will not be necessary to flag crossing when traffic signals are lined.

Green "X" for movement over Third St. will be displayed in next regular sequence after initiation. This may require one minute to elapse between initiation and display of green "X".

For movements from yard toward 9th and Brannan Sts., operation of traffic signals will be initiated by occupancy of track circuit between Santa Fe 25th St. lead and Third St.

For movements toward yard, operation of traffic signals will be initiated upon display of proceed indication on interlocking home signal located 25 feet west of Third St.

Engine or cars must not be left standing within track circuit extending 118 feet west of interlocking home signal 25 feet west of west curb line of Third St. unless interlocking home signal displays "Stop" and button has not been pushed.

Engines or cars must not be left standing within track circuit extending between Santa Fe 25th St. lead and Third St.

**Third and Army Sts., X-ing 4L-2.3C.** City traffic signals are connected with UP track circuits. Rail movements will be governed by traffic signals which will display a green "X" as proceed indication. It will not be necessary to flag crossing when traffic signals are lined.

Occupancy of track circuit extending 50 feet west and 50 feet east of Third St. will initiate signal for rail movements. Movement should not be made into this track circuit unless movement is to continue onto or across Third St.

Signal will be displayed for rail movement in the next regular sequence following occupancy of track circuit. This may require one minute to elapse after occupancy of track circuit before display of proceed indication.

Engines or cars must not be left standing within 50 feet of curbs of Third St.

**Pennsylvania Ave. and Army St. X-ing 4L-2.6C and 4L-2.58C.** Amber light on top of signal case adjacent to crossing operates in conjunction with the flashing light signal.

When the amber light displays a steady aspect it indicates that engine or cars are in the track circuit that controls the flashing light signals. When the amber light displays a flashing aspect it indicates that the crossing protection has been in operation for the required twenty seconds.

Stop clear of crossing within signal circuit. Proceed over crossing on flashing aspect in accordance with traffic conditions.

In event amber light is inoperative, stop clear of crossing for twenty seconds and then flag across the crossing.

**McKinnon Ave. X-ing 4L-3.28C.** Stop and flag.

**Loomis and Industrial Sts., X-ing 4L-3.70C.** Stop and flag.

**Illinois at Marin St.** Stop and flag.

#### Reno Branch

**North Reno, Parr Blvd., MP 28.2.** Crossing gates must lower before crossing is entered unless protected by employee acting as flagman. Approach circuits on spur track extend about 30 feet from edge of crossing. Movements from Intermodal tracks will not actuate circuit until reaching main track, near edge of crossing.

#### Reno

**Sierra Pacific Spur, Valley Road MP 30.7.** Approach crossing at not to exceed 10 MPH. Approach circuits for crossing signals extend approximately 400 feet either side of crossing.

**Surprise Valley Rd Crossing MP 31.5.** On all tracks except main track, stop within signals circuit and do not enter until signals working unless crossing is being flagged.

**6th St.** Crossing protected by flashing lights, gates and bell. Approach crossing carefully. Westward train or engine movements from Team Track, TIP 923, Passing Track,

TIP 921, or lead off Ramp, TIP 931, must stop and ascertain that crossing gates are down before entering crossing.

**4th St.** Protected by flashing lights and crossing bells. Approach crossing carefully.

**Crossings east and west of Nevada Transportation Co. warehouse.** Stop and flag.

#### Loyalton Branch

**Loyalton Hwy 49 X-ing 4-E-12.4.** Stop and flag.

#### Tracy Branch

**McArthur Rd. X-ing 4C-0.5.** Stop and flag.

**San Jose Branch.** (See special instructions. San Jose Branch, Niles Jct. for Morrison Canyon Road.)

#### Milpitas

**Landess Ave. X-ing 4G-12.3.** Stop and flag. Applies to switching operations only on any of the three tracks.

#### San Jose

**Alma Ave. X-ing 4G-19.81C (SP Interchange Tracks) (Tracks Nos. 181 and 182, SP Nos. 325 and 223).** Amber lights that operate in conjunction with traffic signals are located on the west side of Alma Ave. crossing adjacent to UP-SP interchange tracks. They govern eastward movements only. Steady aspect indicates track circuit occupied and flashing aspect indicates traffic signals have been actuated about ten seconds. Stop within the circuit as indicated by steady amber light. Proceed over crossing when amber light flashes in accordance with traffic conditions. If amber lights are inoperative, stop and flag crossing. Cars must not be left within 100 feet of Alma Ave.

**Fifth and Keyes X-ing 4G-20.1C.** Amber lights that operate in conjunction with flashing light traffic signals installed on signal case adjacent to crossing. Steady aspect indicates track circuit occupied and flashing aspect indicates traffic signals have been actuated for about 20 seconds. Stop clear of crossing within the circuit as indicated by steady amber light. When light becomes flashing, proceed over the crossing in accordance with traffic conditions. Should lights fail to operate stop clear of crossing for twenty seconds and then flag the crossing.

**Lincoln Ave. X-ing 4G-22.1C Spur 481 to Contadina.** See instructions for Fifth and Keyes and be governed by those instructions.

**Seventh St. X-ing 4G-20.18C Almaden Wine Spur 399.** Stop and flag.

#### Sacramento Northern

City Ordinances require all trains and yard engines operating on city streets within one hundred feet of an intersection to stop immediately on the approach of any police, ambulance, or fire apparatus sounding siren or signal. If occupying intersection when such emergency vehicles approach, clear crossing and then stop.

Civil, Military or Funeral processions must not be obstructed.

#### Chico Branch

#### Marysville

**All street crossings.** Stop and flag.

#### Yuba City

**Bridge and Shasta Sts. X-ing 8-137.2.** Traffic signal preemption equipment is in service at intersection of Bridge and Shasta Streets. Track circuits extend approximately 150 feet each side of crossing. When train or engine occupies the track circuit, traffic signals will be preempted and will, after a pre-determined time, change to flashing red indication. When traffic signals display a flashing red indication, and it is safe to do so, train or engine may proceed over the crossing.

**Bridge and Plumas Sts. X-ing 8-137.3.** Traffic signal preemption equipment is in service at intersection of Bridge and Plumas Streets. Track circuits connected to the traffic signals extend approximately 30 feet each side of the crossing, track circuits extend approximately 50 feet east of Bridge Street and are so arranged when a train or engine occupies the circuit, traffic signals will be preempted and will, after a predetermined time, change to flashing red indication. When traffic signals display flashing red indication, and it is safe to do so, train or engine may proceed over the crossing. When switching or through movements are to be made on the main track affecting vehicular traffic on Bridge Street, wait for the traffic signals to display flashing red indication before proceeding into the vehicular traffic lanes on Bridge Street.

**Cooper Ave. X-ing 8-137.7.** Two cantilever type flashing signals in service. Trains or engines approaching crossing on main track must observe that amber light installed on top of signal instrument case adjacent to the crossing which operates in conjunction with the automatic crossing signals is flashing before entering crossing. If the amber light is not flashing, stop and flag the crossing.

Movements over the crossing on other than the main track will be governed as follows:

(1) Stop clear of crossing. When the amber light displays a steady aspect, it indicates that engine or cars are in the track circuit that controls the flashing light signals. When the amber light displays a flashing aspect, it indicates that the crossing protection has been in operation for the required twenty seconds.

(2) Wait until steady aspect of amber light changes to a flashing aspect (after about 20 seconds).

(3) Proceed over crossing on flashing aspect in accordance with traffic conditions.

(4) In the event the amber light is inoperative, stop clear of the crossing for twenty seconds and then flag across.

#### Yuba City and Paloso

**Clark Ave. X-ing 8-137.8, Gray Ave. X-ing 8-138.1, Gomez Rd. X-ing 8-138.4, State Hwy X-ing 8-138.8.** The following applies at each of the four crossings: Amber lights which operate in conjunction with the automatic crossing signals are located on top of signal instrument cases adjacent to the crossings. Trains and engines approaching these crossings must observe that amber light is flashing before entering the crossing. If the amber light is not flashing, stop and flag the crossing.

## Durham to Chico

**Oroville-Durham Rd. X-ing 8-177.5.** Stop and flag.

**County Rd SP X-ing C-178.2.** SN trains entering or leaving SP main track at junction switch, stop clear of road crossing. Do not block the road crossing with standing train as it may obscure view of the wigwag signal for vehicles approaching from the south.

**Chico (See also Rules 17-C, 17D, 18 and 1118.6. SN special instructions — general and Chico Branch.**

All city streets. Trains and engines must use caution where movements are made against current of vehicular traffic and must stop if necessary before crossing traffic lanes.

A lighted fusee must be placed at the rear of all eastward movements on city streets. Engines so equipped will display oscillating or revolving lights for all movements within Chico yard limits.

**21st and Fair Sts. X-ing 8-183.31C.** Flashing lights in service.

The signal for southbound vehicular traffic is a standard No. 8 flashing light and for northbound traffic is a cantilever type No. 8 signal. The approach circuit for eastward movements located 213 feet west of the crossing is near the frog of the house track switch, marked by a white stripe on the pavement. An indicator located on the cantilever signal mast will display a steady white aspect when crossing signals begin to operate. After the expiration of twenty five (25) seconds the aspect will change to flashing white. Eastward trains and engines are prohibited from entering the intersection until flashing white aspect is displayed.

The approach circuit for westward movements is located at Laurel Street, 440 feet east of the crossing. Speed of trains and engines must not exceed ten (10) MPH between Laurel Street and the crossing to allow crossing signals to operate twenty five (25) seconds in advance of movement entering the crossing.

Do not leave cars or engines within signal circuit limits except on leaving movement after signals have cut-off. Before making reverse movement, comply fully with above regulations.

If crossing signals fail to operate, crossing must be flagged.

**Park Ave. X-ing 8-183.51-C (spur).** Stop and flag.

**Main St.** Trains, cuts of cars, or single cars or locomotives shall not be permitted to stop or stand on any track located on Main St., except to do so for vehicular traffic, traffic signals, or in the event of emergencies such as derailment or mechanical failure.

Trains and engine movements are prohibited on Main Street, Chico, between the hours of 7:00 a.m. and 7:00 p.m.

Freight trains are limited to engine and 20 cars on Main Street, Chico.

**Main St. and Park Ave. between First St. and Humboldt St. and 12th, 14th and 16th Sts.** Track circuits connected to traffic signals are installed on Main Street and Park Avenue, Chico. Traffic signals are located at each of the intersections between First Street and Humboldt Street (just west of 9th St.) and at the intersections of 12th, 14th and 16th Streets.

The track circuits extend approximately 40 feet on each side of the intersections and are so arranged that when an engine or train occupies the circuit, traffic signals are preempted and signals governing movements on Main Street and Park Avenue will display a flashing yellow aspect and those governing movements on the intersecting streets will display a flashing red aspect. The flashing aspects will continue until the rear of the train clears the track circuit in the intersection.

Movements on Main Street and Park Avenue will proceed without stopping when the flashing yellow aspect is displayed.

### Tarke Branch

**Township Rd. X-ing 8C-1.6.** Stop and flag.

**Acacia Rd. X-ing 8C-5.1.** Stop and flag.

### Pearson Branch

**Pearson Highway Crossing X-ing 8L-129.4.** All trains, engines and cars must come to a stop and no movement made over the crossing until a member of the train crew, or other competent employee, acting as a flagman, has protected the traffic on the highway. After stopping, and when traffic on the highway permits, and it is safe to proceed, the employee acting as a flagman shall display a lighted fusee, day or night until front end of engine or car passes over the crossing.

### Westside

Rice Mill Lead and River Spur over all highway crossings. Trains and engines approaching highway crossings on the Rice Mill Lead and River Spur at MP 92.35, Westside, Sacramento yard, will allow not less than twenty (20) seconds to elapse from time flashing light crossing signals start operation before engines or cars enter the highway traffic lanes. Indicators are installed on the crossing signal masts which govern movements in the Westward direction only and operate in conjunction with the highway crossing signals.

When train or engine occupies approach circuit, indicators will, after a lapse of twenty (20) seconds, display a flashing yellow aspect indicating that the crossing signals are operating and train or engine may proceed.

If the flashing light indicators fail to operate, allow not less than twenty (20) seconds to elapse before entering the highway crossing.

If crossing signals fail to operate, flag the crossing.

### Woodland Branch

**Kiesel Hwy, X-ing 8B-8.0.** Slow to 15 MPH until engine enters crossing.

### Holland Branch

**Linden Rd. X-ing 8-89.7.** Stop and flag.

**Davis Rd. X-ing 8-88.5.** Stop and flag.

**Jefferson Blvd. MP 10.4, X-ing 8J-9.9.** Stop and flag.

## Pittsburg Branch

**Loveridge Rd., East Pittsburg, just east of MP 48.6.** Must not be blocked between 430PM and 445PM.

### Pittsburg

**All Street Crossings not otherwise restricted.** 10 MPH.

**Harbor Blvd. X-ing 8N2.6.** Stop and flag.

**PG&E X-ing, MP 46.25.** Sound whistle signal 14.11. 5 MPH while engine passes over crossing.

### Pt. Chgo

**Main St., X-ing 8-39.2.** Stop and flag.

### Dozier Branch

**Northgate Rd. X-ing 8F6.4.** Stop and flag.

### Montezuma Branch

**Gum Grove Hwy X-ing 8-53.9.** Stop and flag.

### Tidewater Southern

City ordinances require trains and yard engines operating on city streets within 100 feet of an intersection to stop immediately on the approach of any police, ambulance or fire apparatus sounding siren or signal gong, except they may be at the time on, or crossing an intersection, in which event crossing must be cleared and then stop. Civil, military or funeral processions must not be obstructed.

**Simms, Franzia Spur, X-ing 75-12.45C.** Amber light on top of signal case adjacent to crossing operates in conjunction with flashing light signals. When displaying a steady aspect, it indicates engine or cars are within the circuit controlling the flashing light signals. When displaying a flashing aspect, it indicates that crossing protection has been in operation for the required twenty seconds and movement may proceed over crossing in accordance with traffic conditions. In the event flashing light signals are inoperative, crossing must be flagged.

**Alba, Winery Spur, X-ing 75-15.4C Rte 120.** Stop and flag.

### Escalon.

**California St. X-ing 75-17.9 and First St. X-ing 75-18.1.** Standing equipment must not be permitted to block both of these crossings simultaneously when switching is being performed in the Escalon area. Also see Rule 103-B.

### Modesto North Yard

**Tully Rd. X-ing 75-28.8C.** Stop and flag.

**Coldwell Ave. X-ing 75-29.21C.** Stop and flag.

**Modesto (See also, Rule 17-C).**

**9th St.** All movements on 9th Street will be governed by traffic signals indication except at 9th and B Streets where traffic lights are synchronized with track circuit and when trains enter circuit lights go red on both 9th and B Streets to stop vehicular traffic and allow trains to proceed through intersection. Trains must not stand in circuit but should proceed so as to reduce delay to vehicular traffic to a minimum.

Traffic signals on Ninth St. will be set to flash amber for Ninth St. and red for cross street during off-peak periods as follows:

Ninth at G, H, I, J, K and L — 1 a.m. to 6 a.m.

Ninth and B — 11 p.m. to 6 a.m.

At Ninth and P Streets traffic signals are synchronized with track circuits. Trains and engines will not foul the intersection until signals governing movement through intersection display flashing red. Signal timing circuits are so arranged that flashing red will not be displayed until after the end of a normal green period for 9th St. traffic.

During the hours of darkness, or when visibility of motorists is impaired by weather conditions, the head brakeman on trains entering or leaving Modesto yard at 9th and E Sts. must drop a lighted fusee to the pavement as near to the center of the intersection as possible.

**"D" St. X-ing 75-30.0.** Amber light on top of signal case adjacent to crossing operates in conjunction with flashing light signals. When displaying a steady aspect, it indicates engine or cars are within the circuit controlling the flashing light signals. When displaying a flashing aspect, it indicates that crossing protection has been in operation for the required twenty seconds and the movement may proceed over crossing in accordance with traffic conditions. In the event flashing light signals are inoperative, crossing must be flagged.

**Turlock, Broadway X-ing 75C-6.05.** Stop and flag.

### Manteca

**Hwy 120, X-ing 75B-4.8.** Stop and flag.

**Moffat Blvd., X-ing 75B-5.1C (Spur).** Stop and flag.

**Spreckels Rd., X-ing 75B-6.3.** Stop and flag.

**Moffat Blvd., X-ing 75B-6.4.** Stop and flag.

## APPENDIX 3. WESTERN DISTRICT — HOT BOX DETECTORS

### Rule 302. Hot Box Detectors

If hot box indicator is displaying a flashing "H" when passed, immediately reduce to 15 MPH avoiding use of train air brakes if possible and prepare to stop at designated stop point unless instructed by Train Dispatcher to disregard the flashing "H." (See instructions following list of detector locations.).

#### Automatic Hot Box Detector

Automatic Hot Box Detector is in service at MP 556.90.

Hot Box Indicator is located on Signal 5596.

"Wait" Indicator is located on Signal 5550.

Hot Box Locator is located at Red House.

Hot Box Indicator will normally display a flashing "H" until approaching train has been checked. If no hot journal has been found, indication will change to steady "H."

Flashing "H" indication will not change if a hot journal has been found and the train must stop at Red House.

The automatic locator at Red House will indicate the location of the hot box in the train in accordance with posted instructions.

"Wait" indicator on Signal 5550 will normally display a steady "W."

If train ahead has a hot journal, Signal 5550 will indicate aspect per Rule 291 and a flashing "W." Following train must stop.

If flashing "W" continues after train has stopped, communicate with train dispatcher for further instructions. If unable to communicate with train dispatcher, train may, after waiting five minutes, pass flashing "W" and be governed by Rule 291.

An indicator lamp is mounted on the Hot Box Detector house. If head end of train finds the indicator lamp displaying a steady light, Hot Box Detector is in service. If indicator lamp is out, Hot Box Detector is out of service. If rear of train finds the indicator lamp displaying a flashing light, a hot box has been found.

#### HOT BOX DETECTORS ARE IN SERVICE AT THE FOLLOWING LOCATIONS:

MP 893.7 between Delle and Burmester

Westbound "H" indicator located MP 891.3

Eastbound "H" indicator located MP 895.8

Westbound trains stop at West Switch Timpie

Phone at signal 8901 is to be used by westward trains when "H" indicator is flashing and radio communication is not available.

Eastbound trains stop at East Burmester.

MP 860.4 between Clive and Low

Westbound "H" indicator located MP 856.4

Eastbound "H" indicator located MP 864

Westbound trains stop at West Clive

Eastbound trains stop at East Low

MP 830 between Arinosa and Barro

Westbound "H" indicator located MP 827.7

Eastbound "H" indicator located MP 832.2

Westbound trains stop at West Arinosa

Eastbound trains stop at East Barro

MP 783.3 between Clifside and Pilot

Westbound "H" indicator located MP 781.5 (East Clifside)

Eastbound "H" indicator located MP 785.5

Westbound trains stop at West Clifside

Eastbound trains stop at East Pilot

MP 733 between Ruby and Ventosa

Westbound "H" indicator located MP 730.14

Eastbound "H" indicator located MP 735.4

Westbound trains stop at West Ruby

Eastbound trains stop at East Ventosa

MP 693.5 between Elburz and Deeth

"H" indicator located MP 697.2. Trains stop at West Deeth

MP 615.4 between Dunphy and Beowawe

"H" indicator located MP 617.6. Trains stop at East Beowawe

MP 585.80 between Ellison and Rennox

"H" indicator located on Signal 5880. Trains stop at East Rennox

MP 503.8 between Jungo and Gaskell

Westbound "H" indicator located MP 501.1

Eastbound "H" indicator located MP 507

Westbound trains stop at West Jungo

Eastbound trains stop at East Gaskell

MP 475 between Ronda and Floka

Westbound "H" indicator located MP 472.5

Eastbound "H" indicator located MP 477.5

Westbound trains stop at West Ronda

Eastbound trains stop at East Floka

MP 434.25 between Phil and Gerlach

Westbound "H" indicator located MP 431.92

Eastbound "H" indicator located MP 436.93

Westbound trains stop at West Phil

Eastbound trains stop at East Gerlach

MP 387.1 between Flanigan and Sand Pass

Westbound "H" indicator located MP 385.3

Eastbound "H" indicator located MP 390.5

Westbound WP trains stop at West Flanigan

Westbound SP trains stop at SP connection Flanigan MP 384.4

Eastbound trains stop at East Sand Pass

MP 358.34 between Red Rock and Doyle

Westbound "H" indicator located MP 355.3

Eastbound "H" indicator located MP 360.2

Westbound trains stop Red Rock, s/o Pozla MP 349.1

Eastbound trains stop at East Doyle

Hot Box indicator will normally display a flashing "H" until approaching train has been checked. If no hot journal is found, the indicator will change to a steady "H."

If "H" indicator is still flashing when passed, a hot journal has been found. Train will reduce speed to 15 MPH and prepare to stop at inspection point shown. In addition, member of crew on engine will call train dispatcher to ascertain if hot box graph shows any extremely high deflections. If so, train should, if practicable stop short of initial switch of siding where inspection is to take place. If train dispatcher observes any high deflections on hot box graph, he should initiate a call to the head end of train involved without waiting to receive a call.

Train crew will communicate with train dispatcher for location of hot journal. He will advise the side of the train noted, the car count ahead of caboose or behind the engine and the axle number from the head end of the car. *IT SHOULD BE NOTED THAT CARS CARRYING REPORTING MARK OF TTFX ARE TO BE COUNTED AS FOUR (4) CARS FOR PURPOSE OF HOT BOX DETECTOR INSPECTIONS. THE TRAIN DISPATCHER WILL HAVE TAKEN THIS SPECIAL CASE INTO ACCOUNT WHEN HE COMMUNICATES INFORMATION TO THE TRAIN CREW FROM THE GRAPH.* The crew must check the car shown, also the car ahead and the car behind that car. It will not be necessary to inspect the entire train with the following exception:

When multiple alarms are seen on the graph, this condition can be caused by heavy braking of the train while passing the detector account sparks generated by the brake shoes, and also by abnormal operation of the carrier system. It is easily possible for a genuine hot box to be missed under these conditions **and the train must therefore be inspected.**

A light out in the "H" indicator must be regarded as a flashing "H."

When a train is stopped by a hot box detector, and if member of crew is unable to contact train dispatcher, entire train must be inspected. When inspection has been completed, Hot Box indication will have been complied with and no further attempt to communicate with train dispatcher concerning hot box indication need be made.

If power is "off" in hot box detector territory, or if Hot Box Detector is temporarily out of service, train dispatcher may instruct crew members to disregard flashing "H" keeping a close watch for hot journals.

**APPENDIX 4 — WESTERN DISTRICT**

**Watch Inspectors  
Safe Coupling Speed  
Railroad Physicians  
Tunnel Locations  
Yard Limits**

**WATCH INSPECTORS**

Location	Name
Oakland	Milen's Jewelry
Oakland	Riskin's Gem Shop
Pittsburg	Woulf & Ury, Inc.
San Leandro	Alphin Jewelers
Fremont	Hoyle Easley Jewelers
Milpitas	Simas' Jewelers
Stockton	W. K. Bank & Son, Jewelers
Modesto	W. P. Shoemaker's
Lodi	Nickel Jewelry
Sacramento	Grebitus and Sons, Jewelers
Sacramento and Citrus Heights	Coronado Jewelers
Roseville	Verne Martin Jewelers
Marysville	Young's Jewelers
Yuba City	Rhoades Jewelers
Oroville	Warren's Jewelers
Quincy	Rollo Jewelers
Sparks	Precision Watch Repair Service
Winnemucca	Dan Ramasco Jewelers
Elko	Monson's Jewelers
Salt Lake City	Burrell Jewelers
Salt Lake City	H. B. Miller Co.

**Rule 2.** Authorized Watches. See Standard Time, Special Rules, System.

**AVOID DAMAGE —  
SWITCH CUSTOMERS' CARS CAREFULLY**

OVERSPEED Couplings are DAMAGING — Here's what happens:

Speed	Safe Coupling Speed
4 miles per hour <input type="checkbox"/>	Damage begins
5 miles per hour <input type="checkbox"/>	2 1/4 times as damaging as 4 MPH
6 miles per hour <input type="checkbox"/>	3 times as damaging as 4 MPH
7 miles per hour <input type="checkbox"/>	4 times as damaging as 4 MPH
8 miles per hour <input type="checkbox"/>	5 times as damaging as 4 MPH
9 miles per hour <input type="checkbox"/>	6 times as damaging as 4 MPH
10 miles per hour <input type="checkbox"/>	

Damage to freight or car can be avoided by always keeping coupling speed within the safe range — **NOT OVER 4 MILES PER HOUR — A BRISK WALK.**

**HANDLE FREIGHT CAREFULLY AND  
KEEP OUR CUSTOMERS!**

**RAILROAD PHYSICIANS AND OCULISTS**

Location	Name	Title
San Francisco	Dr. T. M. Werges	Chief Surgeon
San Francisco	Dr. Ruth Fleming	Local Surgeon
San Francisco	Dr. L. A. Simpson	Orthopedist
San Francisco	Dr. L. D. Bryson	Local Surgeon
San Francisco	Dr. W. J. Ferguson	Oculist
San Francisco	Dr. W. Casey	Oculist
Emeryville	Dr. C. F. Burton (On Duty Injuries Only)	Local Surgeon
Oakland	Dr. R. F. Westerfield	Local Surgeon
Oakland	Dr. John Chokatos	Local Surgeon
Oakland	Dr. Bruce H. O'Neil	Local Surgeon
Oakland	Dr. Joseph R. Carlisle	Oculist
Hayward	Dr. H. C. Crockett	Local Surgeon
Hayward	Dr. R. C. Crockett	Local Surgeon
Hayward	Dr. B. Fisher	Local Surgeon
Hayward	Dr. C. L. Ritchey	Oculist
Fremont	Dr. C. Addario	Local Surgeon
San Jose	Dr. R. A. Larocca	Local Surgeon
San Jose	Dr. W. A. Johnson	Local Surgeon
San Jose	Dr. J. Condie	Local Surgeon
San Jose	Dr. P. D. Anders	Ophthalmologist
San Jose	Dr. R. C. Rayfield	Oculist
Tracy	Eaton Avenue Medical Group	Local Surgeons
Modesto	Husband Medical Group	Local Surgeons
Turlock	Dr. E. H. Johnson	Local Surgeon
Manteca	Dr. R. P. Carter	Local Surgeon
Stockton	Dr. E. G. Hermosillo	Local Surgeon
Stockton	Dr. V. S. Solis	Local Surgeon
Stockton	Dr. O. R. Vannucci	Local Surgeon
Stockton	Dr. J. D. Wilson	Local Surgeon
Stockton	Stockton Orthopedic Medical Group	Orthopedists
Stockton	Delta Orthopedic Medical Group	Orthopedists
Stockton	Dr. L. Boettger	Local Surgeon
Stockton	Dr. J. H. Holmes	Local Surgeon
Stockton	Dr. Dusan Hutak	Local Surgeon
Stockton	Dr. W. H. Plageman	Oculist
Stockton	Dr. H. J. Zeiter	Oculist
Stockton	Dr. H. E. Hand	Oculist
Lodi	Dr. W. G. Fessler	Local Surgeon
Lodi	Dr. J. D. Fessler	Local Surgeon
Sacramento	Dr. B. A. Daley	Local Surgeon
Sacramento	Dr. R. M. Zinky	Local Surgeon
Sacramento	Dr. J. W. Swingle	Local Surgeon
Sacramento	Dr. J. A. Berg	Oculist
Sacramento	Dr. R. L. Alexander	Oculist
Sacramento	Dr. J. J. Fisher	Oculist
Sacramento	Dr. A. Calkin (Medical Only)	Local Surgeon
Sacramento	Dr. D. O. Kilroy (Medical only)	Local Surgeon
Sacramento	Dr. M. D. Schermer	Oculist
Marysville	Dr. L. D. Bugni	Local Surgeon
Oroville	Dr. E. S. Fortner, Jr.	Local Surgeon
Oroville	Dr. W. H. Bunstock	Local Surgeon
Oroville	Dr. J. Floyd	Local Surgeon
Oroville	Dr. N. F. Brooks	Oculist
Oroville	Dr. K. L. Wedin	Oculist
Quincy	Dr. M. L. Whitney	Local Surgeon
Quincy	Dr. T. Buckley	Local Surgeon
Quincy	Dr. L. A. Price	Local Surgeon
Quincy	Dr. S. M. Gonzalez	Local Surgeon
Greenville	Dr. B. Scherr	Local Surgeon
Westwood	Dr. Vincent Natalie	Local Surgeon
Fall River Mills	Dr. N. E. Wilson	Local Surgeon
Portola	Dr. G. Hesselschwerdt	Local Surgeon
Portola	Dr. L. J. Dura	Local Surgeon
Reno	Dr. D. E. Guisto	Local Surgeon
Reno	Dr. K. F. Maclean	Local Surgeon
Reno	Dr. W. M. Tappan	Local Surgeon
Reno	Dr. R. P. Schultz	Local Surgeon
Reno	Dr. G. F. Magee	Oculist
Reno	Dr. Grant Anderson	Local Surgeon
Winnemucca	Dr. K. L. Hartoch	Local Surgeon
Winnemucca	Dr. A. T. Brown	Local Surgeon
Elko	Elko Clinic	Local Surgeons
Elko	Dr. W. Fritsche	Oculist
Wendover	Wendover Clinic	Local Surgeons
Tooele	Tooele Clinic	Local Surgeons
Salt Lake City	Dr. H. B. Harmon	Local Surgeon
Salt Lake City	Dr. R. W. Ward	Local Surgeon
Salt Lake City	Dr. J. H. Quinn	Oculist
Salt Lake City	Dr. B. J. Fairbanks	Oculist

Additional specialists at most locations. Contact Chief surgeon.

**WESTERN DISTRICT**

Number	TUNNEL LOCATIONS		Length
	West Portal	East Portal	
1	32.12	32.94	4320.9
2	33.39	33.47	407.3
3	57.67	57.75	414.7
4	224.66	225.12	2410.0
5	227.34	227.90	2922.5
6	228.14	228.63	2583.0
7	229.54	230.38	4406.5
8	230.42	232.11	8856.3
9	236.37	236.48	551.8
10	237.01	237.05	231.8
11	237.33	237.37	223.8
12	237.69	237.70	51.4
13	244.92	244.96	195.9
14	246.25	246.29	244.9
15	250.10	250.69	3117.81
16	257.43	257.54	600.9
17	257.85	257.91	324.5
18	258.08	258.11	150.1
19	258.16	258.19	164.0
20	258.32	258.38	291.5
21	258.85	258.93	405.0
22	259.55	259.61	306.1
23	262.87	263.11	1257.7
24	263.89	264.01	616.1
25	265.20	265.23	186.4
26	271.58	271.66	446.0
27	278.42	278.49	364.4
28	278.96	279.06	608.6
29	279.19	279.30	587.8
30	279.55	279.65	537.5
31	280.08	280.21	687.3
32	280.37	280.48	595.2
33	283.06	283.30	1270.7
34	283.71	283.77	304.6
35	297.18	298.57	7343.7
36	316.00	316.14	762.7
37	340.34	341.47	6001.7
39	635.37	635.57	1080.7
40	636.8	636.86	322.0
41	649.24	649.68	2341.8
42	650.71	650.91	1071.7
43	753.69	754.76	5675.9

Number	FOURTH SUBDIVISION		Length
	West Portal	East Portal	
1	0.00	0.12	685.9
2	0.97	1.08	588.3
3	2.61	2.73	621.0
4	3.39	3.47	470.2
5	3.71	3.76	278.7
6	21.03	21.24	1103.0

**WESTERN DISTRICT  
YARD LIMITS**

EAST MP		WEST MP
----	Salt Lake City	926.06
674.6	Elko	663.6
7.7	Oakland	----
----	San Francisco	All Trackage
21.3	Reno	----
----	Loyalton Branch	Entire Branch
BN86.5		
(3.1 miles east of station)	Bieber	111.2
10.1	San Jose	23.0
	SN	
134.7	Marysville-Yuba City	139.6
139.6	Colusa Jct.	140.2
0.0	(Tarke Branch)	0.5
4.9	Sutter	5.6
181.8	Chico	188.8
134.4	Pearson Branch	129.7
104.7	Rio Linda	102.5
96.4	Sacramento	90.4
0.0	(Woodland Branch)	1.85
11.5	Conaway-Woodland	16.7
48.6	Pittsburg	44.5
43.25	McAvoy-Nichols	40.6
39.7	Port Chicago	38.6
6.7	Cannon-Vacaville	4.2
	Montezuma Branch	Entire Branch
	TS	
0.0	Stockton/Manteca Jct.	5.8
13.5	Simms	15.2
19.0	Escalon	21.0
25.3	McHenry/Turlock	47.9
----	Manteca Branch	Entire Branch
----	Chemurgic Branch	Entire Branch

# SPECIAL RULES — SYSTEM

Includes all Districts except Western District.

## Definitions

**Coded Cab Signal — Safety Control System (CCS-SC)** — A cab signal system which activates a full-service brake application if a more restrictive block or interlocking signal change is not acknowledged within six seconds.

**Controlled Point (CP)** — A location where signals and/or switches of a CTC System are controlled by train dispatcher or control operator.

**Controlled Point Number** — A number, assigned to a controlled point, which designates the location of the controlled point (to the nearest milepost). When necessary to contact train dispatcher or control operator, employees must use controlled point number to identify their location. (Numbers will be designated in timetable and by bulletin).

**Tons Per Operative Brake** is defined as the gross trailing tonnage of the train divided by the total number of cars having operative brakes. For example, total train weight 6,000 tons, total cars 100, all brakes operating — divide 6,000 by 100 and there are 60 tons per operative brake. For Four-Runner see Special Rule 1038(R-1).

**Horsepower Per Trailing Ton** is defined as the total horsepower of all working locomotives divided by the total trailing weight of the train in tons. For example, a train powered by five SD40-2 locomotives, or 15,000 horsepower, and having a train weight excluding locomotive of 4,285 tons, for a 3.5 horsepower per trailing ton ratio.

## General Rules

A (R). Second paragraph of General Rule A is amended as follows:

Employees whose duties are in any way affected thereby must have a copy of the current timetable and special rules, and valid certificate of operating rules examination card in their possession while on duty.

G (R). The use of alcoholic beverages, marijuana or other illegal drugs by employees subject to duty is prohibited.

Being under the influence of alcoholic beverages, marijuana or other illegal drugs while on duty or on company property is prohibited.

The use or possession of alcoholic beverages, marijuana or other illegal drugs while on duty or on company property is prohibited.

Being under the influence of prescribed drugs which affect alertness, coordination or reaction response in an unsafe manner while on duty or on company property is prohibited.

M (R). Fifth and Sixth paragraphs of General Rule M of Operating Rules is cancelled and following applies:

Train and engine service employees must not occupy the roof of any freight car or caboose under any circumstances. Other employees whose duties require them to occupy the roof of a car or caboose may do so only when equipment is standing.

## Standard Time

2 (R). Wrist watches approved for use under Rule 2 are:

Ball "Official Railroad Standard";

Ball "Automatic Trainmaster" model;

Bulova "Accutron-Railroad Approved" model, including Quartz & Calendar model;

Bulova Quartz Ladies "Railroad Approved" model, Style No. 92278;

Caravelle Quartz "Railroad Approved";

Citizen Quartz "Railroad Approved";

Elgin "B. W. Raymond" model;

Hamilton electric "Railroad Special";

Longines Model "T-905" Railroad Watch;

Longines "Ultra-Chron Railroad Watch";

Pulsar "Railroad Approved", including Ladies Model;

Seiko Quartz "Railroad Approved" model, including calendar model;

Seiko Ladies Quartz Model UX015M;

Wylar Incaflex Dynawind — R. R. Approved Model;

Wylar Incaflex Stemwind — R. R. Approved Model;

Wylar Dyna Quartz — R. R. Approved Model.

2 (R-1). Operating Rule 2 is modified by the addition of the following:

**EXCEPTION:** Employees working in the classification of Yard Helper will not be required to have a railroad grade watch until such employee has accumulated one year's seniority.

3 (R). Conductors and engineers of other railroads, who have made and registered watch comparison at beginning of trip or shift, will not be required to make and register watch comparison at initial station on Union Pacific.

## Train Order Protection

12 (R). Referring to Rule 12(A), Conductor pilots working with Maintenance of Way equipment must be governed as follows:

Locomotive cranes, Burro cranes or other type equipment that may foul adjacent main tracks when working on double or triple main tracks or any time they are working on adjacent track and fouling main tracks, must be protected by Form "Y" train order on adjacent main tracks that may be fouled.

After conductor pilot has received his copy of Form "Y" train order and the yellow-red and green signals are displayed, work may be performed and men and machines may foul or occupy designated track within the prescribed limits during the time designated in the order without flag protection. The conductor pilot must keep a constant lookout for train or engine and if a train or engine is seen or heard approaching, unless all men and machines are clear of the track, he must go towards the train or engine and flag it with hand signals. If men and machines are clear of main track, conductor pilot will give a proceed signal to the approaching train or engine using a yellow flag or yellow light for this purpose, or conductor pilot may personally inform engineer of the approaching train or engine by radio that it is safe to proceed.

When radio communication is used for this purpose, Special Rule 12(R) on inside of front cover of timetable must be rigidly adhered to.

## Engine Whistle Signals

14 (R). In multiple track territory the following whistle signals must be used for recalling flagman:

Whistle signal as provided by Rules 14(d) and 14(e) followed by one short sound of the whistle for No. 1 track, two for No. 2, three for No. 3, and four for No. 4 track.

## Headlights, Strobe and Revolving Amber Lights

18 (R). Headlight must be displayed to front and rear of yard engines at night and at any time the view is obscured by storm or fog. When not provided with rear headlight, a white light must be displayed.

**EXCEPTION:** When handling cars, headlight need not be displayed on end of engine coupled to cars.

## Markers

19 (R). Referring to Rule 19 (B). Except within the states of California and Colorado reflectorized metal flags may be used as markers during daylight hours.

19 (R-1). Engine or engines operating without cars or cabooses on a main track outside of yard limits must display rear headlight on low beam to rear of movement at all times.

19 (R-2). Employees responsible for display of marker or markers must determine that they are operative.

## Classification Signals

21 (R). Operating Rule 21 is no longer in effect and is cancelled in its entirety.

## Blue Signal Protection of Workman

As used in Special Rule 26(R), 26(R-1), 26(R-2), 26(R-3) and 26(R-4) following definitions apply:

"Workman" means railroad employees assigned to inspect, test, repair or service railroad rolling equipment, or their components, including brake systems. Train and yard crews are excluded, except when assigned to perform such work on railroad rolling equipment that is not part of the train or yard movement they have been called to operate.

"Rolling Equipment" means engines and railroad cars.

"Blue Signal" means a clearly distinguishable blue flag or blue light by day and a blue light by night; blue light may be displayed either steady or flashing.

"Effective locking device" when used in relation to a manually operated switch or derail means a lock which may be locked and unlocked only by craft or group of employees applying that lock.

26 (R). A blue signal indicates that workmen are on, under, or between rolling equipment, and that the equipment must not be coupled to or moved. Other equipment must not be placed on the same track so as to block or reduce the view of the blue signal, except on engine service tracks and car repair tracks or when a derail is used to divide a track into separate working areas.

Blue signals must be displayed by each craft or group of workmen and may only be removed by the same craft or group that placed them.

26 (R-1). Workmen may not work on, under or between rolling equipment on any track other than a main track unless:

(1) Each manually operated switch providing access to that track is lined against movement to that track, secured by an effective locking device, and a blue signal is placed at or near each manually operated switch; or

(2) A derail capable of restricting access to the portion of track where work will be performed is locked in derailing position with an effective locking device, and:  
— Positioned at least 150 feet from the rolling equipment to be protected; or  
— Positioned at least 50 feet from the end of an engine on an engine servicing track where speed does not exceed 5 MPH.

A blue signal must be displayed at each derail.

On a main track a blue signal must be displayed at each end of the rolling equipment.

Whenever one switch of a crossover is located beneath rolling equipment which is under blue signal protection the next switch of the crossover must be lined and locked against movement to that crossover. A blue signal need not be displayed at either crossover switch.

When workmen are working on, under or between an engine or rolling equipment coupled to an engine, a blue signal must be displayed on the controlling unit at a location where it is readily visible to the engineer or operator at the controls of that engine.

When emergency repair work is to be done on, under or between the engine, or cars coupled to an engine, and a blue signal is not available, the engineer must be notified by a member of the crew, or by a workman and protection given those engaged in making the repairs. Engine or cars must not be moved, nor air brakes applied or released, until all employes are clear and the engineer so advised by the same employe.

### Engine Servicing Facilities

**26 (R-2).** An engine may not be moved onto or off a designated engine servicing track under the exclusive control of mechanical forces unless the blue signal is first removed:

From the entrance switch to the service track, and the engine which is placed on the track is stopped short of coupling to another engine or;

From the controlling unit to be moved and from the service track departure switch, before the engine is removed from the track.

An engine protected by blue signals may be moved on a track within the designated engine servicing area under the exclusive control of mechanical forces, when operated by an authorized employe under the direction of the employe in charge of the workmen, after the blue signal has been removed from the controlling engine to be repositioned, and the workmen on the track have been notified and are clear of the movement.

### Car Shop or Repair Track Protection

**26 (R-3).** A blue signal must be placed at the entrance switch to a repair track or a car shop when workmen are working on, under or between rolling equipment. Each manually operated switch providing access to the track must be lined against movement to the track and secured with an effective locking device.

Rolling equipment protected by blue signals on car shop or repair tracks which are under exclusive control of car department forces, may be repositioned with a car mover when operated by an authorized employe under the direction of the employe in charge of the workmen, after the workmen on the track have been notified and are clear of the movement.

Rolling equipment must not be placed on repair tracks or in car shops until it is known that all employes are clear of the track on which the movement is to be made.

### Hump Yard Tracks & Tracks with Remotely Controlled Switches

**26 (R-4).** Workmen may not work on, under or between rolling equipment unless the person in charge of the workmen has notified the operator of the remotely controlled switches of the work to be performed, and has been informed by the operator that protection has been provided. Before the operator of the remotely controlled switches informs the employe in charge of the work that protection has been provided, each remotely controlled switch providing access to the track must be lined against movement to that track, and locked by applying an effective locking device to the lever, button or other device controlling the switch.

The operator may not remove the locking device unless he has been informed by the person in charge of the workmen that it is safe to do so.

The operator must maintain for 15 days a written record of each notification which contains the following information:

The name and craft of the employe in charge who provided the notification;

The number or other designation of the track involved;

The date and time he notified the employe in charge that protection has been provided; and

The date and time he was informed that the work had been completed, and the name and craft of the employe in charge who provided this information.

Each manually operated switch providing access to that track must be protected per Special Rule 26 (R-1).

### Calling Signals

**34 (R).** Employes located in the operating compartment of an engine must communicate to each other in an audible and clear manner, the name or aspect of each signal affecting movement of their train or engine, as soon as the signal is clearly visible or audible. It is the responsibility of the engineer to have each employe comply with these requirements, including himself.

It is the engineer's responsibility to have each employe located in the operating compartment of the engine maintain a constant lookout for signals and conditions along the track which affect the movement of the engine or train.

If a crew member becomes aware that the engineer has become incapacitated or should the engineer fail to operate or control the engine or train in accordance with the signal indications or other conditions requiring speed to be reduced, other members of the crew must communicate with the crew member controlling the movement at once, and if he fails to properly control the speed of the train or engine, other members of the crew must take action necessary to ensure the safety of the train or engine including operating the emergency valve.

### Movement of Trains

**81 (A-R).** When a train or any on-track equipment, either on main track or on siding, is to be stopped to be met or passed by another train, or is stopped by a CTC signal at leaving end of a station, stop must be made not less than 300 feet from fouling point or signal when length of train will permit.

Train or on-track equipment must remain at this location until proper signal to proceed is received.

### Yard Limits

**93 (R).** Union Pacific Operating Rule 93 is revised as follows:

Yard limits will be designated in timetable and the yard limits indicated by "Yard Limit" signs.

Within yard limits the main track may be used without authority conferred by timetable, train order or clearance.

Within yard limits all trains and engines, except first class trains, must move prepared to stop short of train, engine or cars and prepared to stop within one-half the range of vision but not exceeding 20 MPH except when main track is known to be clear by block signal indication. NOTE: Known to be clear by block signal indication means only when the signal displays a green aspect.

Within yard limits where the main track is protected by a continuous block signal system, protection against other trains or engines is not required.

Within yard limits where the main track is not protected by continuous block signal system protection as prescribed by Rule 99 must be provided against first class trains.

A train or engine must not move against the current of traffic within yard limits unless authorized by yardmaster or by train dispatcher where there is no yardmaster and provision has been made for protection of the movement. When moving against the current of traffic all trains and engines must move prepared to stop within one-half the range of vision but not exceeding 20 MPH.

Second class trains, extra trains and engines must avoid delay to first class trains within yard limits.

**93 (R-1).** Consolidated Code Rule 93 is revised as follows:

Yard limits will be indicated by yard limit signs. Stations where yard limits are in effect will be designated by timetable, train order, bulletin, general order or special instructions.

The main track(s) within yard limits may be used clearing the time of first class trains when due to leave the last station where time is shown. In Non-ABS territory, in case of failure to clear the time of first class trains, protection must be provided as prescribed by Rule 99. Protection against second and third class trains, extra trains and engines is not required.

All trains and engines, except first class trains, must move within yard limits prepared to stop within one-half of the range of vision but not exceeding 20 MPH, unless main track is known to be clear by block signal protection. When moving against the current of traffic or on portion of double or two or more tracks used as a single track within yard limits, all trains including first class trains must move prepared to stop within one-half the range of vision but not exceeding 20 MPH.

Movements against the current of traffic within yard limits must not be made unless authorized by train order or protected by yardmaster or other authorized employe.

Information on delayed first class trains may be issued by the train dispatcher either verbally or by message to yardmaster or member of a crew.

### Clearances

**97 (R).** Within CTC territory, assigned locals, work trains or helper engines, having received Clearance Form 2643 at their starting point, may thereafter move in either direction within CTC territory while on continuous tour of duty being governed by indication of signals or instructions from train dispatcher without receipt of additional Clearance Form 2643.

### Railroad Crossings and Junctions

**98 (R).** See Appendix 1

### Flag Protection

**99 (R).** Union Pacific Operating Rule 99 is revised as follows:

Unless otherwise provided, when a train is moving on main track at less than one-half the maximum authorized timetable speed for trains at that location, protection must be provided by a member of the crew dropping off lighted fuses at intervals that do not exceed the burning time of the fuses.

When moving at more than one-half the maximum authorized timetable speed for trains at that location, but under circumstances in which the train could be overtaken, the crew member responsible for providing protection will be governed in the use of fuses by the grade, track curvature, weather conditions, sight distance, and relative speed of his train to following trains.

When a train stops, except when clear of the main track, a member of the crew must go back immediately with flagman's signals a sufficient distance to insure full protection. One-half mile from the rear of his train he will place two torpedoes on the rail; continuing back one and one-half miles from the rear of his train he will place two torpedoes on the rail. He may then return one-half the distance to his train where he must remain and flag approaching trains until relieved or recalled.

When required by rule, the front of the train must be protected by a member of the crew going forward immediately with flagman's signals. One-half mile from the front of his train, he will place two torpedoes on the rail; continuing forward one and one-half miles from the front of his train he will place two torpedoes on the rail. He may then return one-half the distance to his train, display a lighted fusee and remain at that location until recalled.

During foggy or stormy weather and in vicinity of obscure curves or heavy descending grades, or if other conditions make it necessary, he must increase the distance, placing two torpedoes at every one-fourth mile beyond the second set of torpedoes.

After the flagman has the necessary torpedoes placed and has returned one-half the distance to his train, when he is recalled he may return removing the two torpedoes from rail placed one-half mile from train if safety to his train will permit.

If the flagman is recalled before reaching the required distance, he will, if necessary, place two torpedoes on the rail.

When returning to rear of his train, flagman must leave a lighted fusee at the location from which he returns and while returning to train, lighted fusees must be left at intervals not to exceed the burning time of the fusees. When train departs, a member of the crew must leave a lighted fusee and must continue dropping off lighted fusees at intervals not to exceed the burning time of the fusees until train speed is not less than one-half the maximum authorized timetable speed for trains at that location.

Should a train be seen or heard approaching before the flagman has reached the required distance, he must at once place two torpedoes on the rail, and if it is by night or during foggy or stormy weather, he must at once place two torpedoes on the rail and leave a lighted fusee at that point and continue in the direction of the approaching train and flag it with a lighted fusee.

#### Flagman's signals:

**Day Signals** — A red flag, not less than ten torpedoes and six fusees.

**Night Signals** — A white light, not less than ten torpedoes and six fusees.

**Note 1** — Where authorized by timetable or special instructions when a train stops on main track where rear of train is protected by at least two block signals, flagman must go back immediately with flagman's signals, but need go back only a sufficient distance to insure full protection against a following train moving at restricted speed.

**Note 2** — Where authorized by timetable or special instructions when rear of train is protected by at least two block signals of a continuous automatic block signal system, protection against following trains on the same track is not required.

**Note 1 and Note 2** in no way modify the requirements for full flag protection under other circumstances or where protection in accordance with Rule 99 is required by other rules. These provisions do not authorize a reverse movement without full flag protection and do not apply to any unit of equipment which does not actuate the block signals or to a work extra on single track.

Where Note 1 or Note 2 are in effect or when a train is relieved from providing flag protection against following trains on the same track by train order or special instructions, dropping off of lighted fusees by a member of the crew when train is moving at less than one-half maximum authorized timetable speed is not required.

#### Helper Units

**100 (R).** EXCEPTION: When utilizing helper units behind the caboose, employees on caboose must ride on helper units during the entire movement.

#### Storm Conditions

**101 (R).** Trainmen and enginemen will promptly notify dispatcher whenever storms are encountered.

**102 (R).** Union Pacific Operating Rule 102 is revised as follows:

When a train is disabled or stopped suddenly by an emergency brake application or other causes, a lighted red fusee must be immediately displayed on adjacent tracks which may be obstructed, including tracks of other railroads, at front and rear of train and flag protection as required by Rule 99 must be provided in both directions. After lighted fusee has been displayed at front of train, headlight must be extinguished. Concurrently, prompt radio transmission must be made stating exact location and status of train. This transmission must be repeated at least two times. Trains approaching disabled train must move at restricted speed and be prepared to stop for flagman or obstruction.

Flagmen must not be recalled until it is known that adjacent tracks are not obstructed or first train has been stopped on each of the adjacent tracks which may be obstructed or when control operator advises he has provided protection against all trains moving towards the disabled train.

In Rule 251 territory, if disabled train was moving with the current of traffic, rear flagman must not be recalled until train dispatcher advises there are no trains moving against the current of traffic on adjacent track.

Before proceeding, it must be determined by inspection that the train involved and the track to be used are safe for movement. A train on an adjacent track must not pass the disabled train unless preceded by a flagman or they have been assured by the conductor of the disabled train that the track is clear and it is safe to proceed.

#### Movement Over Public Crossings

**103 (R).** See Appendix 2

#### Crossovers and Turnouts

**104 (R).** See Appendix 3

#### Handling of Switches

**104 (R-1).** See Appendix 4

**104 (H-R).** Derail switch stand targets are in the process of being changed on an as-needed basis from the present red to a reflectorized purple target with a white letter D.

#### Train Orders

**200 (R).** The first sentence of Union Pacific Rule 200 is revised as follows:

Train orders will be issued over the signature of the train dispatcher and such signature must be placed directly under the last word of the order.

Balance of rule unchanged.

**204 (R).** Referring to Rule 204 (A) time in body of train orders need not be stated in words on the preprinted Form Y train order only.

**214 (R).** Referring to UP Rule 214(A) and Consolidated Code Rule 214:

Relieving Conductor and Engineer when practical, must also compare all train orders, clearances and instructions with the train dispatcher before proceeding.

Y (R). Union Pacific Operating Rule Form Y train order is revised as follows:  
ON \_\_\_\_\_ AT FOLLOWING

(SUBDIVISION) (DATE)  
LOCATIONS ALL TRAINS MUST PROCEED AT RESTRICTED SPEED UNLESS PROPER VERBAL INFORMATION IS RECEIVED FROM FOREMAN IN CHARGE OR PROCEED SIGNAL GIVEN WITH YELLOW FLAG OR YELLOW LIGHT IS RECEIVED

WHILE PROCEEDING AT RESTRICTED SPEED TRAINS MUST BE PREPARED TO STOP SHORT OF MEN AND MACHINES ON OR FOUL OF TRACK

Time From To	Track(s) Affected	Between MP and MP	Foreman's Name	Location of yellow/red sign when other than prescribed distance/location
--------------	-------------------	-------------------	----------------	--

#### Clearances

**220 (R).** Before giving "OK" time to clearance, the train dispatcher must transmit maximum authorized speed for train being cleared to the operator who must write speed in space provided on clearance and repeat speed to the train dispatcher, who will then record speed authorized on clearance page in train order book.

Unless otherwise restricted, speed shown on clearance is maximum speed and must not be exceeded.

Conductors and engineers must, and other members of crew will check clearance to see that maximum authorized speed is designated.

#### Automatic Block Signals

**240 (R).** Operating and Maintenance of Way Signal Rule 240(C) is modified as follows:

Aspect	Name	Indication
Flashing red light on any signal	Flashing stop and proceed.	Stop before any part of train or engine passes the signal. Block occupied. Proceed at restricted speed.

**240 (R-1).** Referring to Rule 240 (F) and Rule 509. Signal name is changed to "APPROACH LIMITED." No change in signal aspect or indication.

#### Speed Signal Locations

**240 (R-2).** See Appendix 5

#### Hold Indicators

**241(R).** When a train is stopped by an automatic block signal to which Hold indicator is attached, a member of the crew must communicate with dispatcher or operator for instructions before proceeding even though Hold indicator is not illuminated.

If unable to communicate with train dispatcher, operator or operating officer, crew must inspect entire train for hot box or other defects. After such inspection, if safe to do so, train may proceed being governed by Rule 509. In CTC territory, train or engine must not proceed except as provided by Rule 269(A) or 269(B).

#### CTC Rule 268

**268 (R).** See Appendix 6

#### Operation Under Staff System

**300 (R).** Staff system will be used for operation of trains on branch or spur lines specified in the timetable.

Where staff system is in effect, the following will apply:

Authority to use staff must be obtained from train dispatcher.

Trains or engines must not occupy branch or spur without staff, which must be secured by the conductor and delivered to the engineer, who must retain the staff until all movements on the branch or spur are completed.

Possession of staff will authorize train to move in either direction on the designated branch or spur without timetable, train order, or clearance authority; and protection of train in accordance with Rule 99 is not required.

After movements on the branch or spur are completed, staff must be returned to staff box, box must be locked, and train dispatcher notified.

**300 (R-1).** Staff system may be used for operation of track motor cars or other MofW on track equipment or to perform work without flag protection on branch or spur lines specified in the timetable.

Where staff system is in effect the following will apply:

Authority to use staff must be obtained from train dispatcher.

Track motor cars or other MofW on track equipment must not occupy branch or spur and work must not be performed on branch or spur without staff unless flag protection as prescribed by MofW Rule 99 (E) is provided.

Staff must be secured by track car operator or MofW foreman or supervisor in charge of MofW on track equipment or in charge of work to be performed, who must retain staff until all movement or work on branch or spur is completed.

Possession of staff authorizes movement in either direction or work to be performed on the designated branch or spur without a track car lineup; and protection in accordance with MofW Rule 99(E) is not required.

After all movement or work on the branch or spur is completed, staff must be returned to staff box, box must be locked and train dispatcher notified.

#### Coded Cab Signal — Safety Control System

**455 (R).** The Safety Control System is being added to the cab signal system and will be installed on all locomotives. This can be recognized by the whistle being changed from an air operated whistle to an electronic whistle.

When a more restrictive cab signal change is not acknowledged within six (6) seconds of its reception, the CCS-SC is designed to cause a Full Service Penalty Brake Application, also causing the P.C. Switch to trip to reduce diesel engine speed to idle when in power.

When a Full Service Penalty Brake Application has been initiated as the result of a cab signal change not being acknowledged within six (6) seconds, the Automatic Brake Valve Handle must be placed in suppression position and left in this position until train or locomotive has stopped. In all cases, the train or locomotive must come to a complete stop before the following procedure is to be started to release brakes and reset the P.C. Switch.

With the Automatic Brake Valve Handle in suppression position:

1. Close throttle to idle position.
2. Acknowledge the signal change with the acknowledging device.
3. After the P.C. light is extinguished, place Automatic Brake Valve Handle in running position.

**NOTE:** The restrictive signal indication must be acknowledged before the brake can be released.

To eliminate sounding of the audible indicator while waiting in a CCS Test Loop, the reverser handle may be placed in "Neutral" or "Reverse" position. This will change the Cab Aspect to display its most restrictive aspect (Red over Yellow). After acknowledging this change, no more signal changes will be received. Since the reverser handle in trailing units is in neutral position, the audible indicator will be automatically disabled. Placing the reverser handle in the "Forward" position will automatically restore the equipment to normal operation.

When entering Cab Signal Territory with the acknowledging handle in Partial Cut-Out position, a signal change must be acknowledged within six (6) seconds.

455 (R-1). When the controlling unit in a locomotive consist dies enroute, attempts to restart this unit may result in a penalty application of the brakes due to:

1. The Coded Cab Signal power supply converter not working, causing the Coded Cab Signal magnet valve to drop out and
  2. Overspeed magnet valve dropping out if battery voltage drops below 40 volts.
- When the controlling unit in a locomotive consist dies enroute, train must be brought to a stop before attempting to restart unit.

#### Automatic Cab Signals

456 (R). Operating Rule 456 does not apply to any train being controlled by an Amtrak unit.

#### Block Signal Rules

516 (R). Where UP Operating Rules and Maintenance of Way Rules 276 (A), 282, 516, 517 and 518 prescribe a wait of three minutes, waiting time under these rules is extended to five minutes.

When using facing point crossover from any track to a main track in Automatic Block Signal territory, switch in track, train or engine is on must be lined first, then wait five minutes before lining crossover switch in main track to be used.

Exceptions as shown in UP Rule 516 and Consolidated Code Rule 513 apply to this movement the same as at other hand operated switches.

#### Radio Rules

650 (R). Radio rules shown in Form 7915 govern use of radio on the Union Pacific Railroad except where the Consolidated Code of Operating Rules are in effect and supersede Rules 650 through 665 as shown in Union Pacific Operating and Maintenance of Way Signal Rule books effective May 1, 1972 and Form 7908 effective October 1, 1974.

670 (R). The transmittal of train orders by radio is approved.

675 (R). Union Pacific Operating Radio Rule 675 as contained in Form 7915 effective August 1, 1977 is revised as follows:

A train order transmitted by radio must not be acted upon until word 'complete' and the time is received and both the conductor and the engineer have received a written copy of the order and have made certain that the order has been read and understood by other members of the crew.

If the word 'complete' or time is not received, train must be brought to a stop at the next station and crew member must contact train dispatcher by phone to complete the order.

A new clearance must be issued each time train orders are transmitted.

#### Firearms

701 (R). UP Rule 701 (E) and Consolidated Code Rule 708 are changed to read as follows:

Employees are prohibited from having loaded or unloaded firearms in their possession while on duty or on Company property, except those employees authorized to do so in the performance of their duties or those given special permission by the Superintendent.

#### Handling Hazardous Material

713 (R). See Appendices 12, 13, 13A and 14

#### Cabooses

714 (R). At points where freezing temperatures occur, stoves in road cabooses must be left burning at all times during cold weather to prevent freezing of water pipes.

714 (R-1). Doors and windows of cabooses must be locked at all times when caboose is unattended at terminals or enroute.

714 (R-2). Employees seated in cabooses, must use seat belts and restraining harness, when cabooses are so equipped.

#### Inspection of Trains

715 (R). A member of crew on the engine must advise crew on rear of train by radio when train is being inspected by other employees.

715 (R-1). On trains provided with bay window type cabooses, trainmen may remain in bay when passing depots and towers.

Employees must not remain in bay on side next to an adjacent track when meeting or passing another train on that track.

Inspection of such train must be made from rear platform of caboose.

#### Accidents

716 (R). In the event of an oil or hazardous material spill from any source that will contaminate the ground or a waterway, it is the responsibility of the employee who discovers this spill to immediately notify the Chief Dispatcher, advising him of the location of spill, amount spilled, material spilled, and distance to nearest public waters, and any other information that may be pertinent.

If possible, the spillage must be stopped as quickly as possible, exercising necessary safety precautions.

#### Passengers on Freight Trains

721 (R). The following passengers may be carried on freight trains between stations at which the trains stop:

Employees holding "Identification Certificate — U.P.R.R. Co." and travelling on company business.

#### Spotting Cars

734 (R). Bulkhead flat cars with longitudinal center beam (or partition) extending entire length of car must be spotted on tracks where they can be loaded or unloaded on both sides and after being spotted, cars must not be moved until they are completely loaded or unloaded. The following are among cars of this type in service:

UP 217000 through 217075  
BN 615750 through 615849  
BN 624100 through 624299  
MILW 63000 through 63099

#### Maintenance of Way Protection

757 (R). Foremen or others in charge of employees working on or about the tracks, must instruct their men to be alert, watchful, and to keep out of danger, and must take necessary precautions to see that men working under their supervision receive warning of approaching trains in time to reach a place of safety.

If an employee, located at the point where men are working on or about tracks, is assigned the sole duty of warning workmen when trains are approaching, such employee must maintain a continuous watch for trains and for any signals from other employees indicating a train's approach and must not perform any other function without first notifying all men working at that location. When so notified, all workmen must immediately move clear of tracks and remain clear of tracks until the employee resumes his assignment unless another employee is designated to take his place.

#### Restricted Cars

800 (R). When conductor takes charge of a train, he must determine if any cars or units are restricted as to speed and promptly advise engineer and dispatcher of any such speed restriction. The engineer will be held equally responsible with the conductor in the event the conductor fails to notify the engineer and engineer does not ascertain this information.

#### Switching Cars

804 (R). Except in humping operations cabooses, outfit cars, flat cars loaded with non-placarded trailers or containers, flat cars or multi-level cars loaded with motor vehicles must not be cut off while in motion and allowed to strike other cars, nor may other cars be cut off while in motion and allowed to strike such cars, or a draft containing such cars.

804 (R-1). Any movement into spur tracks, inside buildings and at end of spur which ends at building or abutment must first have hand brakes set on lead car or cars of movement and if necessary to couple to cars already on these tracks, hand brakes must be checked on these cars to know properly set before coupling into. Cars must not be permitted to roll free on such tracks. Hand brakes must be set on each end of cut of cars left inside buildings.

804 (R-2). When placing cars at rail trailer facilities or auto ramps, cars must be coupled and sufficient hand brakes must be applied on cars on both ends of track to prevent movement.

804 (R-3). When road engines are to be coupled to a train, whether in a yard or on line, the movement must be stopped 150 feet from the train and further movement must be preceded by a member of the crew when it can be safely done.

804 (R-4). On tracks equipped with Rabbit System Car Puller, all movements on track must be made in normal line of direction. At loading facilities equipped with car puller look out for cable lying along track and cars must not be moved if cable attached to car.

804 (R-5). Outfit cars converted from passenger train cars contain equipment highly subject to damage from slack action or rough handling.

These cars must be handled with air brakes cut in and operative.

### Cars or Loads of Excess Dimensions

**805 (R).** All cars (both loads and empties) which have overall dimensions exceeding published clearances or whose movement is subject to regulation by State Public Service Commissions, maximum over-all dimensions will be furnished from the Office of General Superintendent of Transportation to District Superintendents of Transportation, General Managers and Superintendents, along with the applicable coded standard operating procedures for certain measurements and conditions which are common to most such cars. The codes involve the use of a number and letter in sequence, 1-A, 2-B, etc., and are self-policing against error and are enumerated below with the restrictions and protective requirements indicated:

- 1-A Protect against other loads exceeding 12 feet wide and all loads and equipment having a width exceeding 12 feet due to track curvature and turnouts, by arranging definite meeting and passing points where track centers will provide safe clearance.
- 2-B This load must not pass or be passed on parallel tangent or curved tracks except at arranged meeting and passing points where track centers will provide safe clearance.
- 3-C This load must not pass or be passed on curved tracks except at arranged meeting and passing points where track centers will provide safe clearance.
- 4-D See that loads and equipment are back of fouling points to clear extreme width of this shipment.
- 5-E Load must be placed on carrying car so that all axles are equally loaded.
- 6-F Separate this load from locomotive or any other heavy load exceeding 220,000 pounds gross weight, by at least three cars not exceeding 220,000 pounds gross weight each.
- 7-G Separate this load from locomotive or any other heavy load exceeding 240,000 pounds gross weight, by at least three cars not exceeding 240,000 pounds gross weight each.
- 8-H Separate this load from locomotive or any other heavy load exceeding 263,000 pounds gross weight by at least three cars not exceeding 263,000 pounds gross weight each.
- 9-I Cannot be handled via Montpelier and must be handled via Ogden between Granger and McCammon.
- 10-J Cannot be handled through Tunnels No. 10 to 17.
- 11-K Cannot be handled through Peninsula Junction Tunnel No. 18 and must be routed via Kenton between Troutdale and North Portland, or via Graham between Troutdale and Albina.
- 12-L Cannot be handled through Bear River Tunnel No. 15 and must be routed via Granger between Ogden and McCammon.
- 13-M Cars are of standard dimensions on the Utah Division but high and/or wide in states of California and Nevada.
- 14-N Cars of standard dimensions for the State of Idaho but high and/or wide in states of Oregon and Washington.

Detailed instructions will be issued to provide proper protection for any conditions not specifically provided for in Code 1-A through 14-N.

There is to be no change in the present method of issuing train orders for excess dimension cars.

### Use of Air Brakes and Hand Brakes

**806 (R) and 806 (R-1).** See Appendix 7.

### Continuous Welded Rail Trains

**809 (R).** Equipment for handling continuous welded rail, or continuous lengths of bolted rail, consists of 26 permanently coupled flat cars with buffer at each end and caboose for MofW supervisor. Couplers are blocked against slack and are highly susceptible to damage from rough handling.

This equipment, loaded or empty, must be handled as a unit with air brakes cut in and operative, must not be switched with and must not be humped. These cars must not be cut off while in motion. Other cars must not be cut off while in motion and allowed to couple to these cars or to a draft containing these cars. The following applies:

#### When Loaded

Maximum speed:

On unrestricted track — 40 MPH;

On restricted track — 20 MPH less than published speed restriction.

Where published speed restriction is 30 MPH or less, maximum speed will be 10 MPH;

Through crossovers or turnouts — 10 MPH.

After entering siding or yard track, train must not proceed until authority is received from MofW supervisor in charge.

Train and engine crews must be alert for any signal or communication from rail train supervisor while train is moving.

This equipment must not be combined with other traffic except that outfit cars, cars containing track material or related items may be handled behind the CWR equipment as directed by the Chief Dispatcher, who will authorize such handling only upon instructions from Chief Engineer. Total consist must not exceed 50 cars.

#### When Empty

A speed of 40 MPH must be not exceeded.

CWR equipment may be handled with other traffic at rear of train only but total consist must not exceed 50 cars.

### Position of Cars in Trains

**809 (R-1).** DODX flat cars 39095-39199 must be handled in rear end of train only.

**809 (R-2).** The following tank cars are in service for movement of phosphorus to various destinations:

MONX 23000 series, gross weight, loaded, 394,500 lbs.

MCPX 23000 series, gross weight, loaded, 394,500 lbs.

FMLX 19000 series, gross weight, loaded, 315,000 lbs. at 40 MPH max.

FMLX 19000 series, gross weight, loaded, 272,000 lbs.

Additional cars of similar capacity and high gross weight may be placed in this service. When this occurs, car series, gross weight, speed restrictions and train handling rules govern accordingly.

When these cars are returned to their loading points, they carry water ballast.

The following governs handling:

**When loaded With Phosphorus:**

Trains handling tank cars containing phosphorus must not exceed 50 MPH.

**EXCEPTIONS:**

(1) All FMLX 19000 series cars and all four-axle cars of similar capacity and maximum gross weight loaded, 315,000 lbs., are restricted to 40 MPH.

(2) Phosphorus unit trains are restricted to 40 MPH.

Loaded tank cars containing phosphorus placarded "FLAMMABLE SOLID" do not have to be separated from each other or any other loaded placarded car except cars placarded "EXPLOSIVES A", "RADIOACTIVE" or "POISON GAS".

*When Loaded With Phosphorus or with Water Ballast:*

These cars must be coupled carefully, must not be humped and must not be cut off while in motion. In switching operations, they must be handled with air brakes cut in and operative.

**EXCEPTION:** At North Platte, Pocatello, Hinkle and Los Angeles, when a train has been bled preparatory to humping cars loaded with phosphorus or with water ballast may be handled without air to remove them from the train.

Except at loading or unloading facilities where derail protection is provided, if necessary to set these cars out or to leave them unattended, they must be coupled to another car of a different type, hand brakes applied on both cars and air reservoirs drained to determine that hand brakes are sufficient to hold the cars.

**809 (R-3).** In freight trains, freight cars 85 feet or more in length must not be coupled to any car 39 feet or less in length. This rule does not apply to SSW trains between Kansas City and Topeka, and ATSF trains between West Abilene and East Salina.

**809 (R-4).** Referring to UP Rule 809 (C). Amend to include Modular housing units. All such cars must be entrained ahead of banded loads. (Oregon Div. Fifth and Sixth Subdiv. and S.I.R.R. see Special Rule 805 (RO-4).

### Units Dead in Train

**809 (R-5).** Foreign line, government, export commercial diesel units, Union Pacific yard-switcher units of any type, to be moved dead in train must be separated from each other and from the engine by not less than five cars and must be entrained not more than 30 cars behind the control unit. **EXCEPTION:** All Union Pacific SW-10 Locomotives (1200 Class) are modified with equipment to permit MU operation. With this modification, 1200 Class locomotives will be moved on head end of train either idling in consist or dead in consist. Waybill instructions must be carefully checked and unless otherwise notified in writing must be complied with. In the absence of instructions relative to speed, a speed of 35 MPH with friction bearings and 50 MPH with roller bearings must not be exceeded with yard-switcher units of the above types dead in train.

### Helper Engines

**809 (R-6).** On freight trains, when helper is to be cut into train, units with combined total of not more than 7500 HP may be cut in ahead of caboose, and must be cut in ahead of cars designated in Rule 809 or cars listed in Special Rule 809 (R-1). If helper engine consists of units, the combined total of which exceeds 7500 HP, helper engine must be cut in ahead of tonnage for all units in excess of 7500 HP. When necessary to cut two helper engines into a train the helper engine with the greatest total horsepower must be cut in nearest head end of train and ahead of the tonnage of the rear helper engine.

**809 (R-7).** When necessary to place power behind caboose to assist a train to the top of an ascending grade, or to a location where the main track may be cleared, not more than two units, not exceeding a total of 7500 HP may be used; other units in locomotive consist must be isolated.

**EXCEPTION:** See California Division Rule 809 (RC).

The foregoing does not modify, in any manner, the requirements of Special Rule 809 (R-6).

### Inspection of Trains

**811 (R).** In addition to making inspection of train as often as practicable as per UP Rule 811 or Consolidated Code Rule 713 (E), when visibility does not permit close observation of train, or when, for any reason in judgment of conductor or engineer additional inspection of train is necessary, such inspection must be made.

**811 (R-1).** When picking up cars which have been set out for storage, trainmen will make walking inspection of cars to know journal brasses have not been removed. Roll-by inspection must be made when cars are being placed in train. After cars are in train, close inspection must be made enroute for hot journals and brakes sticking.

## Hotbox and Dragging Equipment Indicators

812 (R). See Appendix 8

### Riding on Engines

816 (R). If there is a trailing "A" unit in locomotive consist, employes in train or engine service required to deadhead on a freight train may occupy cab of such unit but must not occupy RCS units.

### Passenger Service

840 (R). All conductors and brakemen must have in their possession the AMTRAK Manual of Instructions For Conductors and Trainmen in AMTRAK Service when on duty in AMTRAK service.

### Inspection of Cars

858 (R). A car set out on line in defective condition must not be moved until inspected by a qualified inspector.

When the inspector has inspected the defective car and determined it is safe to move, he will attach two bad order cards to each side of the car.

The cards will bear the notation MOVEMENT RESTRICTIONS, stating defect, shop car will move to, and movement restrictions, including miles per hour restriction, if necessary to handle on rear end only, and any other applicable restrictions.

The train dispatcher will be notified when car is ready for movement and given precise information as to the movement restrictions applied to the car.

If the conductor in charge of the train in which the defective car is to move does not receive prior written information relative to movement restrictions applicable to the car, then he must remove one of the bad order cards from the car so that he will have written information relative to the restrictions. In either case, the conductor must inform all other crew members of the presence of the defective car in the train and of all restrictions applying to the car. (See page 241 Instructions For Safety Inspection).

860 (R). Instructions on Way Bills are summarized on Conductor's Car and Tonnage Report in the "Special Handling Column" by initials. Explanation of initials follows:

HS	HOME SHOP
HWI	HIGH/WIDE
RE	REAR ENDER
R50	SPEED RESTRICTION (No's indicate Maximum speed)
SLO	TIME OR SPEED RESTRICTION
WVI	WAIVE INSPECTION
DAN	DANGEROUS
DNH	DO NOT HUMP
EXP	EXPLOSIVE
LOD	EXCESSIVE WEIGHT
POG	POISON GAS
RAM	RADIOACTIVE MATERIAL
UOS	UNLOAD FROM ONE SIDE
DNS	DO NOT SEPARATE
HIV	HIGH VALUE
HTR	HEATERS IN CAR
MIC	MESSANGER IN CHARGE

### Unattended Locomotives

871. (R). UP Rule 871 (A) is modified as follows and the following is added to Consolidated Code Rule 920:

When a locomotive is left unattended, when practical, locomotive must be placed on a track that is protected by a derail or coupled to a car or cars with hand brakes applied on not less than 10 cars or on all cars if coupled to less than 10 cars.

Reverse lever must be placed in neutral position and handle removed and placed in receptacle provided. Independent brakes must be fully applied and generator field or exciter switch placed in "OFF" position. Hand brakes must be set on each locomotive and wooden blocking must be placed under front and back of one pair of wheels. Windows must be closed and latched and when possible, cab doors locked.

EXCEPTION: At locations listed below, if locomotive is equipped with operative safety control feature and engines are idling, hand brakes need not be applied or wooden block placed under wheels. This does not modify the requirements of Air Brake Rule 1044 (B).

### NEBRASKA DIVISION

Beatrice	Gothenburg	Lincoln
Central City	Grand Island	North Platte
Columbus	Julesburg	Omaha
Council Bluffs	Kearney	Sidney
Cozad	LaSalle	Sterling
Fremont	Lexington	Valley
Gering		

### WYOMING DIVISION

Cheyenne	Rock Springs
Commercer City	Roydale
Denver	Walden
Fort Collins	
Greeley	
Green River	
Laramie	
LaSalle	
Ogden	
Rawlins	

### KANSAS DIVISION

Abilene	Marysville
Beloit	Oakley
Bonner Springs	Plainville
Hastings	Salina
Manhattan	St. Joseph
Junction City	Topeka
Kansas City	
Lawrence	

### UTAH DIVISION

Milford  
Ogden  
Provo  
Salt Lake

Blackfoot  
Boise  
Burns  
Cascade  
Council  
Dillon

Aberdeen  
Albina  
Argo  
Arlington  
Auburn  
Ayer  
Boardman  
Cascade Locks  
Centralia  
Chehalis  
Colfax  
Condon  
Eastport

### CALIFORNIA DIVISION

Colton — Service Track  
Las Vegas — Diesel Shop Receiving Tracks  
Los Angeles — Diesel Spur Back Shop

### IDAHO DIVISION

Emmett  
Glenns Ferry  
Idaho Falls  
Kemmerer  
Montpelier  
Nampa  
Nyssa

Pocatello  
Rupert  
Shoshone  
Silver Bow  
Soda Springs  
Twin Falls

### OREGON DIVISION

Grandview  
Heppner  
Hinkle  
Hood River  
Hoquiam  
Ione  
Kalama  
Kellogg  
Kelso  
Kennewick  
Kent  
La Grande  
Moscow

Olympia  
Redmond  
Sandpoint  
Spokane  
Sumner  
Tacoma  
The Dalles  
Trentwood  
Troutdale  
Walla Walla  
Wallula  
Yakima

### Engine Service

871 (R-1). Diesel locomotives left standing for a period of four or more hours shall be shut down. This will apply any time the outside temperature is 40 degrees or above. This includes all units which are set out on line, local units, and units used within yards which will not be used within this time restriction.

876 (R). Firemen and Firemen in training, when competent, may handle the locomotive under the close supervision of the Engineer under the following circumstances, the Engineer being responsible:

In Road Freight services;

In Yard service, provided the Fireman is a promoted Engineer or a Fireman in training;

In Passenger service, under the close supervision and responsibility of the Engineer, provided the Fireman is a promoted Engineer.

878 (R). When taking charge of locomotive in road service, the engineer must check to see that speed recorder, on units so equipped, is provided with speed tape. If speed tape is missing, train dispatcher must be so advised at first opportunity. Speed tapes will be applied and removed only by Mechanical Department employes or Operating Department officers.

EXCEPTION: Engineer will not be required to check for speed tape if unit is equipped with Pulse speed indicator.

879 (R). When a unit fails enroute, causing engine to shut down or be isolated, engineer must immediately contact train dispatcher, who will advise engineer if and at what point train should be stopped so engineer can attempt to start failed unit. If unable to start unit, engineer must manually drain unit if temperature is or is expected to be 32 degrees or less.

Failed unit must be inspected by engine crew to determine if there is any indication of wheel/slip/slide. Train dispatcher must be notified by first available means of communication of defective locomotive. Train dispatcher must notify MP&M forces at next crew change location to permit proper inspection and, if necessary, a tag must be applied to both the defective locomotive and to the lead unit of the consist so that the relieving crew is aware of the defective unit in the consist.

Locomotives set out en route for various defects will be inspected by a qualified MP&M employee, who will apply 2 tags listing nature of defect, movement restrictions, if any, destination and signature of employe making inspection. It will be the responsibility of the crew that picks up the defective locomotive to take one of the 2 tags on the defective locomotive and attach it to the clipboard or control stand on the lead unit in the consist.

883 (R). In territory where rail detector cars are operating, trains and engines must use sand where necessary to overcome slippery condition caused by solution from detector car deposited on rails. Train dispatchers will advise engineers where detector cars are working.

### Amtrak Units

886 (R). Electro-pneumatic brakes have been disconnected on AMTRAK units therefore it will be necessary to operate such units with straight pneumatic brakes.

### Track Restrictions

899 (R). Unless otherwise provided, GE U-28-C, U-30-C, SD-40, SD-40-2, GP40X, SD-45, and units of 5000 HP or more must not be operated on branch lines or on industry tracks without permission from train dispatcher or other officer.

Operation of these units should be restricted to main track, sidings and yard tracks necessary for the movement of trains and the servicing of the units.

(For restrictions on specific tracks, See Appendix 9).

899 (R-1). 9000 class locomotives must not exceed 10 MPH less than maximum authorized timetable speed on the following branches:

**NEBRASKA DIVISION**  
 Albion  
 Loup City  
 Norfolk  
 Cedar Rapids

**UTAH DIVISION**  
 Cedar City  
 Malad  
 Syracuse  
 Cache Valley  
 Evona

**KANSAS DIVISION**  
 Grand Island  
 Solomon

**WYOMING DIVISION**  
 Ft. Collins  
 and Boulder Branch.

**CALIFORNIA DIVISION**  
 Anaheim

**IDAHO DIVISION**  
 Goshen  
 Hill City  
 Idaho Northern  
 Boise  
 Grace  
 Homedale  
 Oakley  
 Oregon Eastern  
 Teton Valley  
 Raft River  
 Yellowstone — between  
 Belt and Ashton

**OREGON DIVISION**  
 Dayton  
 Pendleton  
 Coeur d'Alene  
 Montessano  
 Pleasant Valley  
 Tucannon  
 Tekoa

### Close Clearances

900 (R). See Appendix 10

### Air Brake Rules

1001 (R). Before moving an engine in engine house or from spot track, it must be known that adequate air pressure is being maintained and that air brake equipment is functioning properly. Application and release test of independent brake must be made and in addition to noting brake cylinder pressure on gauge, visual inspection must be made to know that brakes apply when independent brake valve is in application position.

At locations where units are cut into or out of an engine consist, it must be known that air brake hoses are coupled, that air is cut in and that brakes are operating properly on all units before any movement is made.

At terminals where hostler relieves incoming engineer, brakes must be tested with independent brake valve immediately after engine is detached from train, to insure that brakes are operating properly.

Movement of engines at enginehouses, servicing or maintenance facilities must not exceed 5 miles per hour.

Engines must be stopped before moving onto a turn-table, and before entering enginehouse or servicing facilities where elevated tracks or pits are used.

The following additional rules and instructions also apply to movement of light engines, particularly around engine houses and servicing facilities:

1. On road freight power, after throttle is initially opened, sufficient time must be allowed for engine and generator to build up sufficient current to move the locomotive.
2. In case of emergency requiring shorter stop than can be made with independent brake, automatic brake valve should be placed in emergency position which will automatically reduce engine speed to idle.

1005 (R). That part of Air Brake Rule 1005 regarding compressor governors is changed as follows:

Compressor governor—Road and switch locomotives —

Main reservoir pressure:

Low pressure ..... 120 pounds  
 High pressure ..... 130 pounds

1005 (R-1). That part of Air Brake Rule 1005 (A) concerning main line passenger trains is changed as follows:

**EXCEPTION:** Union Pacific locomotives used as controlling unit in main line passenger service — 105 lbs. brakepipe pressure. (Amtrak locomotives will remain 110 lbs.). Balance of rule unchanged.

1011 (R). Cut-out cocks to safety control feature and to overspeed control removed from all locomotives. Exception: Safety control cut-out cocks have not been removed from remote RCS units.

1022 (R). All trains must be given inspection and test as prescribed by Rule 1025 at points:

1. Where train is originally made up.
2. Where train consist is changed other than by adding or removing a solid block of cars, and the train brake system remains charged.
3. Where the train is received in interchange if the train consist is changed other than by:
  - A. Removing a solid block of cars from head end or rear end of the train.
  - B. Changing motive power.
  - C. Removing or changing the caboose, or
  - D. Any combination of changes in (A), (B), and (C).

1025 (R). After the air brake system on a freight or passenger train is charged to within fifteen (15) pounds of the feed valve setting on locomotive as indicated by an accurate gauge connected to the brake pipe at rear of train, and upon receipt of proper request or signal to apply brakes for test, a twenty (20) pound brake pipe reduction must be made from pressure indicated by brake pipe gauge on locomotive. After making twenty (20) pound brake pipe reduction and immediately after the brake pipe air has stopped exhausting at the automatic brake valve, pressure maintaining feature must be cut out. Then after waiting one minute for brake pipe pressure to equalize, brake pipe leakage test must be made for one minute. Brake pipe leakage must not exceed five (5) pounds

per minute. On a freight train, one long sound of locomotive whistle must be sounded to indicate brakes are applied for test. Inspection of the train brakes must be made to determine that angle cocks are properly positioned, that the brakes are applied on each car, that piston travel is correct, that brake rigging does not bind or foul, and that all parts of the brake equipment are properly secured.

When inspection of the application of train brakes is completed, and upon receipt of proper request or signal to release brakes, pressure maintaining feature must be cut in and air brakes must be released. On a freight train, two long sounds of locomotive whistle must be sounded to indicate that brakes have been released. Each brake must then be inspected to see that all have released. The release inspection may be made as the train departs.

A qualified person participating in the test and inspection or who has knowledge that the test was made shall notify the engineer that the initial terminal road train air brake test has been satisfactorily performed.

The qualified person shall provide the notification in writing if the road crew will report for duty after the qualified person goes off duty. The qualified person also shall provide the notification in writing if the train that has been inspected is to be moved in excess of 500 miles without being subject to another test.

Engineers receiving written notification will accept this as authority that the initial terminal road train air brake test has been satisfactorily performed. Engineers must leave written notification on locomotive for relieving engineers at crew change locations.

1030 (H-R). Piston travel of a body-mounted brake cylinder must not exceed 10½ inches and piston travel of all other brakes must not exceed the nominal travel specified by more than 2 inches or must not exceed the maximum travel specified by the badge plate stencil on the car.

Air Brake Rules 1031, 1031(A), 1031(B), 1031(C), and 1031(D) contained in Form 7170 effective December 15, 1974, are cancelled in their entirety.

1032 (R). On arrival of freight trains at terminals where facilities are available for immediate air brake inspection and repairs, engineer should place automatic brake valve handle in "Handle Off" position. When brake pipe pressure has been reduced TO INDICATE A READING of 20 pounds or less on locomotive gauge, engineer must give one long sound of locomotive whistle as a signal to trainmen that brake application has been completed and locomotive may be detached. Trainmen must not close angle cock on locomotive until this signal is received. In all cases, angle cock must be left open on the portion of the train left standing.

### Braking Freight Trains

1038 (R). When making a service stop or reducing speed of a freight train, initial brake pipe reduction must be made, after which, sufficient time must be allowed for proper adjustment of slack in train before further brake pipe reduction is made to required amount. After initial brake pipe reduction is made, throttle must be reduced gradually as speed of train reduces. When train has reached point where it is evident it will stop within the next forty (40) feet, a further brake pipe reduction must be made of sufficient amount to have air exhausting from automatic brake valve, throttle must be closed, rails sanded and independent brake fully applied on all locomotives on head end as train comes to stop.

To maintain authorized speed at any location, if the amount of brake pipe reduction exceeds 20 lbs., the train must be stopped immediately, using emergency position if necessary, sufficient hand brakes applied, air brakes inspected and, if found to be in suitable condition for safe operation, brake pipe must be fully recharged before releasing hand brakes and proceeding. If train cannot be held with independent brake fully applied on all locomotives, sufficient retainers must be set.

1038 (R-1). For the purpose of calculating tons per operative brake for the 4-Runner — 4 deck — Intermodal Car Series 60001 through 60099 are to be calculated as two operative brakes for each car in this Series.

1039 (R). Some Union Pacific GP-9 class units and certain foreign line units including all Burlington Northern units are not equipped with dynamic brake interlock feature whereby the locomotive air brakes will be released during dynamic braking when train brakes are applied.

When operating with these GP-9 units or with foreign line units in any consist, whether all of one road or mixed with Union Pacific units, arrange to keep locomotive brakes released by actuating brakes off when automatic brake valve is used to apply train brakes during dynamic braking.

1039 (R-1). While in dynamic brake, in order to prevent run-out and possibly a break-in-two due to loss of dynamic brake resulting from emergency or penalty application of train brakes, all Union Pacific locomotives equipped with dynamic brake have been modified to provide continuous dynamic brake any time an emergency or penalty application of the brakes occur from any source.

Maintaining dynamic brake in a consist will be dependent upon controlling unit having this modification.

When using train brakes in conjunction with dynamic brake, independent brakes must be actuated off at frequent intervals to insure that locomotive air brakes on all units in consist are kept released.

### Retaining Valves

1042 (R). The following will govern the use of retaining valves:

When, in the judgment of the conductor or engineer the use of retaining valves is necessary to control the train properly, retaining valves must be used at any point.

Unless otherwise specified, when use of retaining valves is required, they must be used on all cars in train, with retaining valves on all loads in heavy holding position.

### Remote Control Retaining Valves

1042 (R-1). On trains which are fully equipped with remote control retaining

valve equipment, including caboose with operative retainer line air pressure gauge, remote control retaining valves may be used in lieu of manual retaining valves.

On engines equipped for remote control retaining valve operation engineer's station is provided with retainer line air pressure gauge, a charging valve equipped with cut-out cock and a globe type release valve. To charge the retainer line, the release valve must be closed and charging valve must be opened.

Caboose equipped for remote control retaining valve operation are provided with a retainer line air pressure gauge, and cut-out cock at each end of the caboose. Cut-out cock at rear of caboose must be closed before attempting to charge retainer line. Approximately 5 minutes is required to charge retainer line to 45 lbs. pressure, or to deplete retainer line to discontinue operation of retaining valves.

When retaining valves are placed in service by remote control, sufficient time must be allowed to charge retainer line before entering retaining valve territory. When retainer line is charged to at least 45 lbs. pressure as indicated on retainer line caboose gauge, rear trainmen must notify engineer. If engineer does not receive such notification, train must not enter territory where use of retaining valves is required until he is advised caboose gauge indicates required pressure, or retaining valves are manually placed in holding position.

When use of remote control retaining valve is discontinued, charging valve must be closed and release valve opened on engine.

While remote control retaining valves are in operation, if an emergency application of air brakes occurs from any source, or pressure in retainer line drops below 30 lbs. as indicated on gauge on caboose, train must be stopped and all retaining valves must immediately be placed in holding position manually before releasing automatic air brakes. Retaining valves must be left in manual operation until point is reached where their use is not required.

When remote control retaining valves are to be used and train is not required to stop, a speed of 8 MPH must not be exceeded over the crest of grade.

#### Pressure Maintaining Braking

1043 (R). In territory where pressure maintaining braking is being used for extended periods, brake valve cut-off valve may be placed in Passenger position. Position of brake valve cut-off valve must not be changed except when brake valve is in Release position.

When operating in Passenger position extreme care must be used as any slight movement of brake valve toward Release position will result in complete release of automatic brakes throughout the train.

Pressure maintaining braking must not be used for extended periods at speeds exceeding 30 MPH. To do so will result in damage to wheels and brake shoes. Application and release method of braking must be used at speeds exceeding 30 MPH, reducing speed sufficiently before release to insure sufficient time for cooling of wheels and recharging brake pipe before it is necessary to again apply brakes.

#### Use of Conductor's Valve

1052. (R). When conductor's valve or caboose valve is opened while train is moving, under no circumstances must it be closed before train has stopped.

**If conductor's valve is placed in emergency on caboose, the engineer must be notified immediately if radio communications are available.**

#### Other Than Normal Stops

1053 (R). When conditions warrant, all available braking power must be used.

**An emergency brake application should be made without hesitation should any condition occur where there is doubt of ability to control train speed with service applications.**

1053 (R-1). If brakes in train are applied with service application from any source other than from use of automatic brake valve on locomotive while using power, Engineer must leave brake valve in "Running" or "Release" position, keep locomotive brake released, and close throttle gradually as speed of train reduces. When train has reached point where it is evident it will stop within next 100 feet, throttle must be closed, rails sanded, and independent brake fully applied as train comes to stop. After stop is completed, engineer must make or observe that not less than a ten (10) pound brake pipe reduction has been made from equalizing reservoir pressure, and must permit this application to equalize throughout train before releasing train brakes.

When an emergency or full service penalty brake application occurs from any source, **THE TRAIN OR LOCOMOTIVE MUST COME TO A COMPLETE STOP** before any attempt is started to release automatic air brakes and reset the P.C. switch.

1053 (A) (R). If brakes in train are applied in emergency from any source other than by automatic brake valve, brake valve must be moved to "Emergency" position and left in this position until train has stopped and equalizing reservoir pressure has vented to zero. Sufficient brake cylinder pressure must be applied to locomotive to control slack, keeping independent brake valve handle depressed in application zone to prevent sliding or overheating wheels. After brakes are released, brake pipe pressure restored, and train brakes applied with a twenty (20) pound brake pipe reduction, pressure maintaining feature must be cut out. Leakage must then be checked to see if within prescribed limits.

If power was being used at time emergency application occurred, throttle must be moved to "Idle" position.

If dynamic brake was in use at time emergency application occurred, brake cylinder pressure on locomotives must be actuated off if dynamic brakes are to continue to be used to assist in stopping.

1054 (R). Units 3489-3808 and 2430-2539 have been modified so that if an emergency application of brakes is received from any source other than the engineer's brake valve or the emergency brake valve in cab of leading unit, there will be a 20-

second delay before power is cut off. (Units listed above, as well as other units so modified, will be indicated by decal on control panel).

1058 (A-R). When piston travel is in excess of 10½ inches, the air brakes cannot be considered in effective operating condition.

#### Mechanical Instructions

1090 (R). When operating with RCS in service and train is to be separated between control unit and remote units, feed valve on remote units must be cut out and remote units must be isolated before separating train.

While control unit is separated from portion of train containing remote units, "Feed Valve Out" indicating light must be on continuously.

Feed valve on remote units must not be cut in, nor may "Mode Selector Switch" be moved from "Isolate" position until the train has been reassembled and brake pipe pressure is being restored on caboose at rear of train from control unit.

RCS Radio Switch must be in "OFF" position while control units are detached from train.

1090 (R-1). If diesel unit is not loading or not making transition, high voltage cabinet contractors must NOT under any circumstances be manually operated.

To determine if the contactors are picking up as they should, the diesel engine should be isolated, then restored to power.

Proper report must be made to the next maintenance terminal.

1090 (R-2). Ground relay protection knife switches are applied for use by electrical forces in making tests of equipment. Under no circumstances may the seal on ground relay knife switch be broken, or knife switch be opened. When seal on ground relay knife switch is broken or is found broken or missing, such information must be included on work report.

1090 (R-3). A locomotive must not be operated at speeds in excess of that prescribed for the unit having the lowest maximum speed as shown on chart in unit.

When applying continuous or short-time ratings as shown on the chart, the unit consist must not be operated lower than the highest minimum speed for any unit and unit consist must not be operated higher than the lowest amperage for any unit.

When operating close to continuous rating under full power, "Minimum Continuous Speed" or "Maximum Amperage," whichever occurs first, is controlling.

Attention is directed to the fact that short-time ratings are not continuous; that is, a unit cannot be operated for 15 minutes at the ¼ hour rating, then for 30 minutes at the ½ hour rating, etc.

If unable to proceed within the limits prescribed, train must be stopped, and facts reported to train dispatcher who will instruct as to reducing tonnage or providing additional power.

1091 (R). On trains having units equipped with fuel saver device, engineer must have device in operation whenever possible in accordance with instructions furnished all enginemen.

#### Sirens

1092 (R). Siren installed on unit 1400 operated by a single throw toggle switch, siren on unit 1402 operated by a single push button and sirens on units 6918 and 6924 operated by a single slide pole switch. On all units so installed switches are on the instrument panel in front of the engineer labeled "Siren."

These sirens are activated by:

- (1) Turning on circuit breaker switch labeled "siren" located on back control panel in cab of unit; and
- (2) Cutting in air valve labeled "siren air cock" located on left side in nose of unit.

It is intended this siren be sounded for an emergency only when approaching and passing gangs or workmen who have not noticed or heard regular horn warning. Sirens are not intended to be used in cities, towns, municipalities or at grade crossings, except in emergencies.

When sirens are used in an emergency situation, radio report of the incident should be made by engineer to dispatcher giving all necessary details.

#### Instructions for Safety Inspection

The last sentence of Section 5 of Form 7160 effective July 1, 1980 which reads as follows; If defect is a safety appliance defect, red tag must be applied to defective part before car is moved, is no longer in effect and the following applies; If defect is a safety appliance defect, car must not be moved in a train movement.

# EASTERN DISTRICT SPECIAL RULES — ALL DIVISIONS

## Engine Whistle Signals

14 (RE). Within the State of Wyoming, duration of complete whistle signal approaching public crossings must be not less than twenty seconds.

## Markers

19 (RE). The use of battery operated flashing light marker lamps as markers is authorized.

## Superiority of Trains

72 (RE). On single track, except in CTC territory, westward trains are superior to eastward trains of the same class. See Rule 72.

## Movements in Yards

93 (RE). While operating on tracks of the BN at Lincoln or Sterling, employees must comply with instructions issued by BN supervisors, but will be governed by UP rules, except Consolidated Code Rule 93 will apply. See Special Rule 93 (R-1).

93 (RE-1). At Grand Island, trains from Kansas Division must stop clear of derail and switch at MP 250.35 and must receive verbal authority from Nebraska Division train dispatcher to proceed on eastward main track.

Trains enroute to Kansas Division will be governed by interlocking signal at BN Crossing and may proceed on route indicated to switch west of Garfield St. Dispatcher's telephone located opposite block signal at MP 148.4.

## CTC Rules

269 (RE). Crossover switches and signals MP 287.9, CP 175 (Jct.), are controlled by North Platte train dispatcher. Switch and signals MP 285.2, South Gibbon, are controlled by Kansas City train dispatcher.

Westward trains stopped at signals MP 285.2 South Gibbon must communicate with both Kansas City and North Platte dispatchers and Form C Clearance to be issued by Kansas City train dispatcher.

Eastward trains stopped at signals MP 287.9 CP 175 (Jct.) must communicate with North Platte dispatcher and Form C Clearance to be issued by North Platte dispatcher.

## Automatic Cab Signals

458 (RE). When a foreign line unit equipped with cab signals is the control unit on a freight train, cab signal devices may be cut out and train must proceed in accordance with the second and third paragraphs of Rule 458.

# NEBRASKA DIVISION

## SPECIAL RULES—OMAHA-COUNCIL BLUFFS AREA

### Movements Between Omaha and 72nd Street

97 (RN). At Omaha for movement of yard engines to and from industrial district at 72nd Street, authority will be conferred by indication of interlocking signal at Summit and instructions from train dispatcher.

When interlocking signal at Summit displays Clear or Approach indication for a switching movement enroute to this industrial district, authority is conferred for movement to crossover at west end of Seymour without receipt of Clearance Form 2643, but oral or message instructions from train dispatcher must be complied with. Interlocking operator must receive authority from train dispatcher before displaying such indications.

On arrival at crossover at Seymour, engine foreman must obtain permission from train dispatcher before crossover switches are opened. If authority is received, crossover movement may be made under block signal protection, but Operating Rule 516 and Special Rule 516(R) must be complied with.

For return movement from Seymour to Summit, engine foreman must obtain permission from train dispatcher before switches are opened or main track fouled. When authority is received, movement may be made without receipt of Clearance Form 2643, but Operating Rule 516 and Special Rule 516(R) must be complied with.

### Railroad Crossings and Junctions

98 (RN). Trains and engines must approach all junction points expecting to find trains entering or leaving main tracks or running tracks.

Except where protected by interlocking, trains entering Bridge Subdivision must receive authority from Bridge dispatcher before occupying main track and must be governed by Rule 516 and Special Rule 516(R).

### Current of Traffic

D-151 (RN). Current of traffic is established as follows:

Main track 3, between 20th Street and Summit — Westward.

Main track 4, between Summit and 20th Street — Eastward.

On double track between Summit and Gilmore Jct., trains and engines must keep to the right.

When authorized by Bridge dispatcher, movements may be made against current of traffic without being preceded by flagman, except when moving over a public crossing protected by automatic signals or gates.

On Running Tracks 7 and 8 between 20th Street and crossover to BN transfer south of Douglas Street, trains and engines must keep to the right. Eastward track is designated as Running Track 7, westward track as Running Track 8.

When authorized by Bridge dispatcher, movements may be made against current of traffic on Running Tracks 7 and 8 between 20th Street and crossover to BN transfer south of Douglas Street without being preceded by flagman.

### Approach Indications

240 (RN). On No. 1 and No. 2 tracks, between MP 2.4 and MP 5.3, a train or engine receiving Approach aspect (Rule 240-D) must proceed prepared to stop before any part of train or engine passes the next signal. Trains exceeding 20 MPH must immediately reduce to that speed.

## SPECIAL RULES—FIRST SUBDIVISION and BRANCHES

### Movements in Yards

97 (RN-1). Yard engines and light engines may occupy main track without Clearance Form 2643 between MP 144.0 and MP 149.5, Grand Island; MP 185.0 and MP 191.0, Kearney; and MP 0.0 and MP 4.0, Kearney Branch.

97 (RN-2). At Columbus, yard engines may move with current of traffic between MP 83.40 and end of switching limits without Clearance Form 2643 on authority from train dispatcher. Permission must be obtained from train dispatcher before entering main track at Moorman. When handling cars behind engine on main track, at night a light must be displayed on that car.

### Movements Against Current of Traffic

D-151 (RN-1). At locations shown below, trains and engines may move against the current of traffic at restricted speed without being preceded by a flagman except when moving over public crossing protected by crossing signals or gates, or when view is obstructed, or when moving through interlocking and conditions require movement be preceded by flagman. Movement may be made only after verbal authority has been granted to occupy track and hold indicators are displayed.

VALLEY, between hold indicators MP 26.7 and MP 30.6

FREMONT, on westward track between hold indicator MP 39.1 and MP 44.8 being governed by signal indication over BN crossing.

SCHUYLER, between hold indicators MP 70.0 and MP 66.9.

COLUMBUS, on westward main track, when eastward dwarf signal displays restricting indication (Rule 240-N) movement may be made against current of traffic to End of Block sign in vicinity of MP 83.5.

Westward automatic block signal at MP 82.5 is a Stop signal (Rule 240-A). Rule 509 governs.

On eastward main track, movements may be made against the current of traffic between MP 83.8 and hold indicator MP 86.2 (Rule 241-B). Movements must be made only after authority has been granted to occupy track and it is known hold indicator is displayed. Operating Rule 103(G) must be complied with.

CENTRAL CITY, intermediate signals, westward signal 1231 and eastward signal 1268 are changed to hold signals controlled by the Train Dispatcher.

GRAND ISLAND, between east remote control switch MP 144.0 and hold indicator located at MP 149.8.

BUDA, protection to move from Kearney to MP 185.5 against the current of traffic. Westward movements only will be protected by the Train Dispatcher holding signal at CP 184 at Buda.

KEARNEY, between hold indicator MP 187.7 and Stop signal MP 190. Eastward automatic Stop Signal at MP 190 is a Stop signal (Rule 240(A) and Rule 509 governs.

COZAD, intermediate signals, westward signal 2377 and eastward signal 2394 are changed to hold signals controlled by the Train Dispatcher.

### Block Signals

509 (RN). Eastward trains stopped at signal MP 39.2 must not proceed until authorized by UP operator, Fremont.

803 (RN) COLUMBUS, eastward trains on Norfolk Branch must have permission to enter Columbus Yard from Columbus operator or North Platte train dispatcher before fouling 29th St. at MP 2.25.

1022 (R-N). Interchange trains received at Fremont from CNW Railroad that meet the provisions of Item 3 of Special Rule 1022 (R) will not require interchange air brake inspection.

## SPECIAL RULES — NORTH PLATTE

### Blue Flag Protection

26 (RB). Three blue flag derrails located west end Diesel Supply, and one blue flag deraill located north of East tower.

### Movements in Yards

97 (RB). At North Platte, trains and engines may move between MP 282 and MP 292 upon authority from yardmaster without Clearance Form 2643.

Movements against the current of traffic may be made at restricted speed when authorized by yardmaster without being preceded by flagman except where view is obstructed and across public crossings protected by gates or crossing signals.

**104 (RB).** If light is not burning in switch point indicators on dual control switches at west end of Diesel Supply, under East Hump, at west and east leg of wye and on Running track north of east tower, trains and engines must stop and inspect switch points to see fully closed and properly lined before moving over switch.

Hostlers must not take any of the switches listed above off power unless authorized to do so by the yardmaster or officer.

Road crews and hostlers must advise yardmaster which track they are moving from and receive authority from him before moving from west end Diesel Supply through dual control switches. Crews on movements into west end Diesel Supply must also receive authority from yardmaster before moving through any dual control switch. If any delay is experienced after receiving authority for movement, yardmaster must be advised of delay and crew must again request authority from yardmaster before moving.

Engines moving out of Diesel Supply with an A unit on each end must be operated from the A unit according to direction in which movement is to be made. This applies regardless of the direction in which the trailing A unit is headed.

#### Speed Restrictions

**105 (RB).** Following speeds must not be exceeded on yard tracks or running tracks shown:

North Running Track, New Westward Coal Track and New Westward Receiving Lead:

Between MP 283.8 and MP 291.24 ..... 35 MPH  
Rule 516 and Special Rule 516 (R) in effect at hand operated switches between MP 283.86 and MP 289.4.

All tracks in Eastbound Yard ..... 25 MPH  
All tracks in Westbound Yard ..... 25 MPH  
Power Lead Over Pass ..... 5 MPH

#### Movements on Westward Main Tracks

**105 (RB-1).** Eastward movements on Westward Main Track are prohibited unless authorized by yardmaster and when so authorized must be made at restricted speed.

#### Block Signals

**509 (RB).** At North Platte, trains or engines stopped by block signals listed below must communicate with humpmaster or yardmaster designated and be governed by his instructions:

Eastward Signal at MP 291.3 } East Humpmaster

Eastward Signals at MP 287.6 } East Tower Yardmaster  
MP 286.6 }

Westward Signals at MP 282.5 } West Yardmaster  
MP 287.6 }

**509 (RB-1).** Yardmaster must be contacted for instructions before passing double block signal at MP 283.4. If unable to contact yardmaster, movement must be stopped and dispatcher contacted by telephone for track to be used.

#### Movements on Ready Tracks

**804 (RB).** Eastward movements from South Diesel Supply ready tracks by road locomotives to yards may trail through Racor 22 switches provided there is no conflicting movements.

(RB-1). Westward movements from South Diesel Supply ready tracks and west shop lead switch and #6 track switch by road locomotives to yards may trail through Racor 22 switches provided there is no conflicting movement.

#### Retarder Yards

**804 (RB-2).** Switching movements handled by car retarder system are controlled by signal indications or as instructed by the yardmaster.

Eastward movements on hump leads are governed by hump signals located at crest of hump, or, on engines so equipped, by special cab signals. Aspect displayed on hump signal is repeated on repeater signals located along lead. Indications of these signals are as follows:

Color	Indication
Red	—Stop
Green	—Proceed (toward hump) not exceeding 8 MPH.
Yellow	—Proceed (toward hump) not exceeding 3 MPH.
Flashing Red	—Back up (away from hump).

Trimmer signals, located at crest of hump control movements from the bowl tracks and switching area, westward over the hump. Repeater signals repeat the indication displayed by the trimmer signal. The indication of these signals is as follows:

Color	Indication
Red	—Stop
Green	—Proceed

Hump signals, trimmer signals and special cab signals are controlled from crest of hump by hump yardmaster, engine foreman or other designated employe.

Air whistles, located near humps, are controlled from tower at crest of hump, and may also be operated by engine foreman or from tower operator's console. Following whistle signals will be used:

One long sound	—Humping operations about to start.
Two short sounds	—Call for maintainer.
Three short sounds	—Call for section foreman.

#### Air Brake Rules

1032 (RB). Special Rule 1032 (R) is in effect at North Platte.

### SPECIAL RULES — SECOND SUBDIVISION

#### CTC Stop Signals

**269 (RN).** At Barnett, westward signals and dual control switches are controlled by Cheyenne Train Dispatcher. Eastward signals (not dual control switches) are controlled by North Platte Train Dispatcher.

# WYOMING DIVISION

## SPECIAL RULES — ALL SUBDIVISIONS

### Movement at Stations

96 (RW). At the following locations, yard engines and light engines may move between "A" signals and switching limit signs without clearance Form 2643 on signal indication and authority from train dispatcher:

Location	Between Mile Posts
Laramie	564.82 Track 1 & 2, B563.59 Track 3 and 570.43
Rawlins	680.10 and 685.16
Rock Springs	800.53 and 804.60

### Block Clearance

96 (RW-1). Train and engine movements on Jim Bridger Spur will be controlled by train dispatcher through issuance of block clearances, Form 2643 BC, via radio or phone to conductor and engineer of train to be moved. All train and engine movements between Point of Rocks MP 1.93 (East Switch) and Pacific Power and Light Plant must be authorized by block clearance and no portion of track between these points may be occupied unless conductor and engineer have a valid block clearance in their possession.

All block clearances must be copied by conductor and engineer and must be repeated by each of them to the train dispatcher and the repeated time given by train dispatcher must be entered, as well as name of person copying block clearance in spaces provided. Train dispatcher must record block clearances in train order book in the following form, assigning a train order number to each, preceding it with the letters BC, thus:

BC 1

Point of Rocks to C&E Eng 201

This is your authority to occupy track between MP 1.93 (East Switch) and Prospect Point

Additional instructions — Do not exceed 20 MPH between MP 2 and MP 3  
JLE

R 1247 PM Condr Jones  
R 1248 PM Engr Smith  
Reported clear at 215 PM

Proper receipt of block clearance by a train or engine is authority for movement from the first named station to the second named station only. Protection of rear of train as prescribed by Rule 99 is not required in block clearance territory. When train or engine authorized by block clearance has arrived in clear at destined station, conductor must report arrival to train dispatcher and enter the time reported clear on the block clearance. No further movement between stations may be made without receipt of another block clearance.

Additional instructions such as, "Do not exceed 10 MPH between MP 2 and MP 3, must be entered on block clearance as transmitted by the train dispatcher. If no additional instructions, the word "NONE" must be entered. Only one block clearance may be issued for a block at one time.

Dispatcher's transfer must include block clearances still in effect.

Block clearance must not be issued until the preceding movement has reported clear of the track.

96 (RW-2). All movements between Ramsey and East Switch are governed by signal indication.

Train and engine movements on Ramsey Spur will be controlled by train dispatcher through issuance of block clearances, Form 2643 BC, via radio or phone to conductor and engineer of train to be moved. All train and engine movements between East Switch and Carbon County must be authorized by block clearance and no portion of track between these points may be occupied unless conductor and engineer have a valid block clearance in their possession.

All block clearances must be copied by conductor and engineer and must be repeated by each of them to the train dispatcher and the repeated time given by train dispatcher must be entered, as well as name of person copying block clearance in spaces provided. Train dispatcher must record block clearances in train order book in the following form, assigning a train order number to each, preceding it with the letters BC, thus:

BC 1

Ramsey to C&E Eng 201

This is your authority to occupy track between East Switch and Carbon County  
Additional instructions — Do not exceed 20 MPH between MP 2 and MP 3 on Arch siding.  
JLE

R 1247 PM Condr Jones  
R 1248 PM Engr Smith  
Reported clear at 215 PM

Proper receipt of block clearance by a train or engine is authority for movement from the first named station to the second named station only. Protection of rear of train as prescribed by Rule 99 is not required in block clearance territory.

Additional instructions such as, "Do not exceed 10 MPH between MP 2 and MP 3, Arch Siding" must be entered on block clearance as transmitted by the train dis-

patcher. If no additional instructions, the word "NONE" must be entered. Only one block clearance may be issued for a block at one time.

Conductor or engineer must report to train dispatcher when clear of locations listed on block clearance and must enter time reported clear at destined station on block clearance form. No further movements between stations may be made without receipt of another block clearance.

All eastward movements must communicate with train dispatcher before departing East Switch. Movements to Rosebud and Carbon County must remain clear of west end of Arch siding and Main track unless block clearance states otherwise.

Block clearance must not be issued until the preceding movement has reported clear of the track.

Dispatcher's transfer must include all block clearances still in effect.

### Retaining Valves

1042 (RW). The tables on pages 163 and 164 govern operation of freight trains and use of retaining valves, in territories shown. This does not modify the requirements of Air Brake Rule 1042:

1. Dynamic brake must be placed in operation and tested at a convenient location prior to reaching designated descending grades.
2. When use of retaining valves is required, these valves must be placed in "HEAVY HOLDING" position on all cars in train.
3. On branch lines, retaining valves must be used on all cars in train descending grades 1.50% or more unless handled by locomotive with effective dynamic brake on units providing not less than one horsepower per trailing ton.

### MofW Block Clearance

1500 (RW). Movement of MofW equipment or work to be performed by MofW forces on Ramsey Spur and Jim Bridger Spur may be controlled by train dispatcher through issuance of block clearances, Form 2643 BC, via radio or phone to MofW foreman or supervisor in charge of work or movement to be made.

Movement of track motor cars, MofW equipment, or MofW work to be performed on either spur may be authorized by block clearance and no portion of track on either spur is to be occupied unless MofW foreman or supervisor in charge has a valid block clearance in his possession.

Block clearance must be copied by foreman or supervisor in charge and must be repeated by him to the train dispatcher and the repeated time given by train dispatcher must be entered in the space provided as well as name of person copying block clearance. Train dispatcher will record block clearance in train order book in the following form, assigning a train order number to each, preceding it with the letters BC, thus:

BC 2

Ramsey (Point of Rocks) to Foreman A B Smith

This is your authority to occupy track between East Switch (Prospect Point Switch MP 6.58) and Rosebud (Pacific Power & Light)

Additional instructions — Men and machines must be clear of track at 215PM  
JEM

R 1250 PM by Foreman Smith  
Reported clear at 210 PM

Proper receipt of block clearance by MofW foreman or supervisor is authority to occupy track between stations named only. Protection as prescribed by MofW Rule 99(E) is not required when foreman or supervisor possesses a valid block clearance in block clearance territory.

Additional instructions will specify when all MofW men and machines must be clear of track and must be entered on block clearance as transmitted by train dispatcher.

Prior to the time specified in additional instructions, all men and machines must be clear of track ready for movement of trains. Foreman or supervisor who was issued the block clearance must observe that all equipment is in the clear and notify all personnel that the track is to be released, and must report to train dispatcher time track cleared and ready for movement of trains, and enter the time reported clear on block clearance. No further work may be performed or movement made on track without receipt of another block clearance.

Train dispatcher must not permit a train or engine to enter a block occupied by MofW forces holding a valid block clearance. Block clearance for a train waiting to move must not be issued until MofW foreman or supervisor who was issued the block clearance has reported men and machines are clear of the track and the track is ready for movement of trains.

## SPECIAL RULES—FIRST SUBDIVISION and BRANCHES

### Use of Engine Bell

30 (RW). Engine bell must be rung continuously while train or engine is moving within city limits of Fort Collins.

### D&RGW Trackage

81 (RW). Following are D&RGW Rules which will apply when using D&RGW trackage between MP 4.0 and D&RGW North Yard, Denver, First Subdivision. Union Pacific crews will be governed by Union Pacific Operating Rules while operating on D&RGW, except the following D&RGW Rules are more restrictive and will apply:

## DRGW DEFINITIONS

- RESTRICTED SPEED** — A speed that will permit stopping short of another train or obstruction, but not exceeding 20 MPH.
- REDUCED SPEED** — A speed that will permit stopping short of another train or obstruction, or anything that may require the speed of a train or locomotive to be reduced.
- MEDIUM SPEED** — A speed not exceeding 30 miles per hour.
- POSITIVE ABS** — An automatic block signal designated by the letter "P".

## DRGW OPERATING RULES:

11. A train or locomotive finding a fusee burning on or near its track, must stop, then proceed at restricted speed for a distance of one-half mile.
12. The explosion of two torpedoes is a signal to proceed at reduced speed looking out for flagman for one and one-half miles and is to be acknowledged as prescribed by Rule 14(g) (2-shorts). The explosion of one torpedo will indicate the same as two but the use of two is required.
105. Unless otherwise provided, a train or locomotive using a siding or any track other than a main track, must move at reduced speed, but not to exceed 30 miles per hour.
509. When a train or locomotive is stopped by a Stop and Proceed ABS, it may proceed at once at restricted speed to the next ABS, expecting to find a train in the block, switch not properly lined, broken rail, mud, rock or snow slides, high water damage, or any other condition that would prevent the safe passage of trains.
- 509-A. When a train or locomotive is stopped by a Positive Stop ABS, it may proceed when the ABS is cleared or when it is authorized to proceed by Permissive Card showing proper form. If the Positive ABS governs entrance to a diverging route, Permissive Card must show on which track train or locomotive must proceed. Permissive card must be repeated to the train dispatcher or operator by the employe receiving it. If it is possible for an opposing train or locomotive to be in the block, the train dispatcher will authorize the train or locomotive to proceed by issuing Permissive Form "A":

FORM "A" — PROCEED ON \_\_\_\_\_ TRACK UNDER FLAG PROTECTION AND ACCORDING TO RULE 509.

When train dispatcher positively knows there is no opposing train or locomotive between the communicating points, Permissive Form "B" will be issued:

FORM "B" — PROCEED ON \_\_\_\_\_ TRACK, AT RESTRICTED SPEED ACCORDING TO RULE 509.

In case a work train is in the block, Permissive Form "C" will be issued:

FORM "C" — PROCEED ON \_\_\_\_\_ TRACK, AT RESTRICTED SPEED, ACCORDING TO RULE 509, LOOKING OUT FOR WORK EXTRA \_\_\_\_\_ IN THE BLOCK.

If movement is to enter siding, Form "D" will be issued:

FORM "D" — PROCEED INTO \_\_\_\_\_ SIDING AT RESTRICTED SPEED, ACCORDING TO RULE 509.

560. If entire train or locomotive has passed an ABS governing its movement, reverse movement must not be made without the proper Positive ABS indication, except when authorized by the train dispatcher, the movement may be made after proper protection has been provided.
561. If the head end of train or locomotive only, passes a Positive ABS and then reverse movement is made so that the Positive ABS is again in advance of the train or locomotive, the train dispatcher or operator must be notified at once.

## DRGW AUTOMATIC BLOCK SIGNALS (ABS)

- 281-B. Red over flashing yellow — Diverging Approach Medium — Proceed authorized speed until entire train is through turnout, approaching next signal medium speed.
282. Flashing Yellow — Approach Medium — Proceed, approaching next signal medium speed.
291. Red — Stop and Proceed — Stop then proceed according to Rule 509.
292. Red — Stop — Indication Stop.

NOTE: A signal mast that has no number-plate or "P" marker is an interlocking signal.

A signal mast that has a number plate only is a Stop and Proceed signal.

A signal mast that has a number plate and a "P" marker is a POSITIVE ABS.

## Movements in Yards

93 (RW). At Denver, movements may be made at restricted speed against current of traffic between 20th St. and Commerce City without being preceded by a flagman except where view is obstructed and when moving across public crossings protected by gates or crossing signals.

96 (RW). Trains which originate at Greeley may occupy main track in CTC territory between MP 45 and MP 57, without Clearance Form 2643, on authority of Train Dispatcher and CTC signal indication.

96 (RW-1). Burlington Northern trains at Greeley may occupy main track in CTC territory between CP 51, MP 50.6 and CP 53, MP 52.5, without Clearance Form 2643, with verbal authority of Train Dispatcher and CTC signal indication. Movement must be made at restricted speed. BN crew must read any notices

posted in CTC Instrument House at MP 52.5 before occupying Union Pacific Railroad trackage.

96 (RW-2). Union Pacific Railroad trains at CP 53 may occupy 13th Subdivision of BN trackage to MP 10 (14th Avenue) without Clearance Form 2643. Rule 105 governs.

104 (RW). At LaSalle, a hand operated derail is installed on DP controlled siding 720 feet east of CP 47.

104 (RW-1). MP 25.13, Fort Collins Branch, hand operated derail is installed on main track 98 feet east of westward signal on BN Railway crossing.

275 (RW). At CP 47, MP 47.2 dual control derail operates in conjunction with dual control switch. When necessary to hand operate dual control switch as provided in Operating Rules 275 and 276, dual control derail must also be hand operated as provided in Operating Rules 275 and 276.

## SPECIAL RULES — SECOND SUBDIVISION and BRANCHES

### Block Clearance

96 (RW). Train and engine movements on Energy Spur and Medicine Bow Spur are controlled by train dispatcher through issuance of block clearance Form 2643 BC via radio or phone to conductor and engineer of train to be moved. All train and engine movements between diverder switch MP 2 which is designated as east switch and MP 12.50 and between MP 12.50 and balloon track on Medicine Bow Coal Spur and between MP 2 and balloon track on Energy Development Spur must be authorized by block clearance and no portion of track between these points may be occupied unless conductor and engineer have a valid block clearance in their possession. Signal indication will continue to govern movement between Hanna and MP 2.

103 (RW). At CP 511 after stopping eastward trains must whistle to activate crossing protection before proceeding.

### Signal Indications

241 (RW). At Hanna, westward movement on Energy Mine Lead MP 2.0 will be governed by three-unit Stop signal as follows:

Westward signal aspect displayed for a straight track movement to Energy Spur will be a green over red over red with a dark (E) Indicator. If this track is lined for Medicine Bow Spur, indication will be a red over red over red with illuminated (E) Indicator. Operating Rule 241-A governs. After train has stopped, lined the switch for Energy Spur, the illuminated (E) will go out and a green over red over red aspect will be received.

With the dispatcher requesting move to the Medicine Bow Track, with the switch properly lined, the westward signal aspect will be red over red over green to go through the No. 10 turnout with a dark (MB) Indicator. If the switch is not lined for Medicine Bow Track, a red over red over red with illuminated (MB) Indicator will be displayed. Operating Rule 241-A governs. After switch is lined for the turnout the switch aspect will change to a red over red over green with (MB) Indicator darkened.

End of the block signs will be located at MP 2.0 on Energy and Medicine Bow Tracks.

267 (RW). At Durrant, when signal governing movement on Arch Mineral Spur No. 1 and at Ramsey, when signal governing movement to Arch Mineral Spur No. 2 display proceed indication, movement is authorized on spur in either direction without flag protection.

If signal fails to display proceed indication, movement on spur must be authorized by Form C Clearance, which must be copied by a member of crew, repeated to train dispatcher and delivered to engineer.

275 (RW). At CP 511, MP 511.0; Ramsey, MP 638.9; Durrant, MP 650.2; and CP 681, MP 681.1 dual control derails operates in conjunction with dual control switches. When necessary to hand operate dual control switches as provided in Operating Rules 275 and 276, dual control derail must also be hand operated as provided in Operating Rules 275 and 276.

### Weigh-In-Motion Scale

804 (RW-1). At Laramie, weigh-in-motion scale is located on yard track No. 1. Lights located on north side of track govern movement approaching scale and when weighing cars and display the following indications:

- |                  |   |
|------------------|---|
| Green-           | Moving at proper speed.   |
| Flashing yellow- | Caution, approaching maximum weighing speed.  |
| Red-             | Unless otherwise instructed, stop movement, back train up and start weighing operation again. |

Speed of 5 MPH must not be exceeded while weighing over scale. Wheels on units must not be allowed to slip or slide while on scale.

### Air Brake Rules

1029 (RW). On passenger trains, running air test as required by Air Brake Rule 1029 must be made at Sherman, by eastward and westward trains, and at Speer by eastward trains.

1044 (RW) Eastward trains must stop at Lake Owens MP 48, Coalmont Branch and fully recharge train line before proceeding.

1044 (RW-1). Prior to trains departing Carbon County Coal Co. Balloon Track, a member of crew must observe that brakes apply and release on rear car of train and brake pipe pressure is restored before proceeding.

## SPECIAL RULES — FOURTH SUBDIVISION and BRANCHES

### CTC Stop Signals

**269 (RW).** Switch at west end Idaho Division siding at West Granger, MP 1.58 is controlled by train dispatcher at Cheyenne.

Eastward trains stopped by Stop signal governing movement over this switch must communicate with train dispatcher, Cheyenne, as required by Rule 269.

Westward trains stopped by Stop signal governing movement over this switch must communicate with both the train dispatcher at Cheyenne, who will authorize hand operation of switch when necessary, and train dispatcher at Pocatello, who will issue Form C Clearance when required.

**269 (RW-1).** Switch at W. Bridge Junction, CP 818, to Riverdale By-Pass Track is controlled by Train Dispatcher at Salt Lake City. Westward trains from Wyoming 4th Subdivision stopped by signal governing movement over this switch must communicate with Train Dispatcher at Salt Lake City.

Westward trains from Utah 1st subdivision enroute to Riverdale By-Pass Track must communicate with both the Train Dispatcher at Salt Lake, who will authorize hand operation of dual control switch, and the Train Dispatcher at Cheyenne, who will issue Form "C" Clearance Form 2643-C.

### Long Crossovers

**516 (RW-1).** At Hampton crossover switches establish block signal protection as follows:

The switch in the westward track, MP 866.4, establishes block signal protection for westward track only.

The switch in the eastward track, MP 866.0, establishes block signal protection for the eastward track only.

### Air Brake Rules

**1029 (RW-1).** Air brakes must be cut in and operative on all cars handled on Stauffer, Allied Chemical, and Texas Gulf Spurs.

Before departure from Stauffer, Allied, Texas Gulf and FMC plant yards, terminal test of air brakes must be made as prescribed by Air Brake Rule 1025.

**1029 (RW-2).** On westward passenger trains, running air test as required by Air Brake Rule 1029 must be made at Wahsatch.

**1029 (RW-3).** Air brakes must be cut in and operative on all cars handled on Park City and Ontario Branches.

## SPECIAL RULES — OGDEN

See Utah Div.

## EASTWARD

Borie to Speer  
Speer to Carr

Tons Per Operative Brake	Effective Dynamic Brake On Units Providing	Retaining Valves	Speed Must Not Exceed
Less Than 60		<b>Refer to Special Rule 1042 (R)</b>	Timetable speeds.
60-80	1 or more HP Per Trailing Ton	"	Timetable speeds.
	Less Than 1 HP Per Trailing Ton	"	30 MPH Borie to Carr
80-100	1 or more HP Per Trailing Ton	"	35 MPH Borie to Carr
	½ HP Per Trailing Ton	"	30 MPH Borie to Carr
	Less Than ½ HP Per Trailing Ton	"	20 MPH Borie to Carr
Over 100	1 or more HP Per Trailing Ton	"	30 MPH Borie to Carr
	Less than 1 HP Per Trailing Ton	"	20 MPH Borie to Carr

## EASTWARD

Buford-Cheyenne

Tons per Operative Brake	Effective Dynamic Brake On Units Providing	Retaining Valves	Speed Must Not Exceed
Less Than 60		<b>Refer to Special Rule 1042 (R)</b>	Timetable speeds.
60-80	1 or more HP Per Trailing Ton	"	Timetable speeds.
	Less Than 1 HP Per Trailing Ton	"	30 MPH Buford to Cheyenne Stop and remain standing 10 minutes at Granite and Borie to cool wheels.
80-100	1 or more HP Per Trailing Ton	"	35 MPH Buford to Cheyenne
	½ HP Per Trailing Ton	"	30 MPH Buford to Cheyenne Stop and remain standing 10 minutes at Granite and Borie to cool wheels.
	Less Than ½ HP Per Trailing Ton	"	20 MPH Buford to Cheyenne
Over 100	<b>IMPORTANT — For movement on descending grades see Wyo. Second Subdiv.</b>		

## WESTWARD

Hermosa to Laramie  
No. 3 Track

Tons Per Operative Brake	Effective Dynamic Brake On Units Providing	Retaining Valves	Speed Must Not Exceed
Less Than 60		Refer to Special Rule 1042 (R)	Timetable speeds.
60-80	1 or more HP Per Trailing Ton	"	Timetable speeds.
	Less Than 1 HP Per Trailing Ton	"	30 MPH Hermosa to Red Buttes.
80-100	1 or more HP Per Trailing Ton	"	35 MPH Hermosa to Red Buttes.
	½ HP Per Trailing Ton	"	25 MPH Hermosa to Red Buttes.
	Less Than ½ HP Per Trailing Ton	"	20 MPH Hermosa to Red Buttes
Over 100	1 or more HP Per Trailing Ton	"	30 MPH Hermosa to Red Buttes
	Less Than 1 HP Per Trailing Ton	"	20 MPH Hermosa to Red Buttes

## WESTWARD

Fourth Sub-Division  
Wahsatch to Ogden

Tons per Operative Brake	Effective Dynamic Brake On Units Providing	Retaining Valves	Speed Must Not Exceed
Less Than 60		Refer to Special Rule 1042 (R)	Timetable Speeds.
60-80	1 or more HP Per Trailing Ton	"	Timetable Speeds.
	Less Than 1 HP Per Trailing Ton	"	20 MPH Wahsatch to Castle Rock. 30 MPH Castle Rock to Ogden.
80-100	1 or more HP Per Trailing Ton	"	25 MPH Wahsatch to Castle Rock.
	½ HP Per Trailing Ton	"	20 MPH Wahsatch to Castle Rock. 30 MPH Castle Rock to Ogden
	Less Than ½ HP Per Trailing Ton	"	20 MPH Wahsatch to Echo 25 MPH Echo to Ogden.
Over 100	1 or more HP Per Trailing Ton	"	20 MPH Wahsatch to Castle Rock 30 MPH Castle Rock to Ogden
	Less Than 1 HP Per Trailing Ton	"	20 MPH Wahsatch to Echo 25 MPH Echo to Ogden.

If the train consists entirely of ore cars in series 26000-26499, 26500-26749 or 27000-27299 and dynamic brake is equal to one-half HP per trailing ton retaining valves need not be used. Speed must not exceed 20 MPH.

## KANSAS DIVISION SPECIAL RULES — ALL SUBDIVISIONS

### Movement in Yards

**96 (RK).** Yard engines and light engines may move without Clearance Form 2643 on signal indication and authority of train dispatcher at the following locations:

<b>Location:</b>	<b>Between</b>
Kansas City	West Yard and MP 7.4
Topeka	MP 66.6 and 75.5, Denver Cut-Off or MP 76.0, West Menoken on 1st Subdivision
Marysville	East switch Upland and west switch Orrick.
Hastings	West switch Anan and west switch Hastings.

**267 (RK).** At Marysville, MP 148.1, eastward train departing from East yard lead must not enter CTC territory until train dispatcher is contacted and must be governed by instructions and signal indication.

**275 (RK).** In Kansas City Yard, MP 3.75 five dual-control switches are in service at the east end of 18th Street Yards on crossover at west end of north and south runner, east end of Old Belt and New Belt, also east end of South Number 3.

**NOTE:** SWITCH WILL HAVE THREE INDICATOR LIGHTS, RED, YELLOW AND GREEN. ONLY IF CROSSOVER IS FULLY NORMAL AT BOTH ENDS WILL IT DISPLAY GREEN. FULLY REVERSE IT WILL DISPLAY YELLOW, OTHERWISE RED.

**803 (RK).** At Marysville, a member of the crew must report to train dispatcher or yardmaster for instructions before coming into yard and must not block Highway 77 crossing.

### SPECIAL RULES—FIRST SUBDIVISION and BRANCHES

#### Rotary Car Dumpers

**98 (RK).** The following applies when operating units through Jeffrey Energy Plant rotary car dumpers:

SD-7, 24, 35, 40-2, 45, U-30-C, GP-20, 30, 35, 38-2 and GP-40-X units only may be operated through dumper.

Locomotive units equipped for RCS operation must not be moved through dumper as antenna associated with RCS equipment will not clear dumper.

Train must be stopped before entering dumper to close side windows and awnings on all units in consist.

All cabooses except BN and UP 25800 series cabooses must be cut off on balloon track near switch before proceeding through dumper. Hand brake on caboose must be applied.

Authority must be received from Dumper Superintendent before proceeding through the dumper.

Members of crews on units must remain entirely inside of units while unit moving through dumpers unless otherwise instructed, rear end crew should remain in vicinity of caboose and perform roll-by inspection as train passes.

#### Movement Over Drawbridge

**98 (RK-1).** From December 16 until March 1, when interlocking signals governing movement over drawbridge at St. Joseph indicate Stop and no conflicting movement is evident, train must be preceded by flagman who will carefully examine route to be used before movement is started over bridge. If conflicting movement is evident, train or engine must not proceed until understanding is had with crew of train on conflicting movement.

**275 (RK-1).** At East Topeka, MP 67.4, off No. 2 Main Track power operated dual control derail operates in conjunction with dual control switches providing access to AT&SF/UP transfer tracks.

When necessary to hand operate dual control switches as provided in Operating Rules 275 and 276, dual control derail must also be hand operated as provided by Operating Rules 275 and 276.

#### Use of Mo. Pac. Tracks at Hiawatha

**516 (RK).** At Hiawatha, before fouling Missouri Pacific Tracks, Rule 516 and Special Rule 516 (R) must be complied with and, in addition, protection as required by Rule 99 must be provided when necessary.

#### Close Clearances

**900 (RK).** At Lawrence, grain aerators operated by the Derby Grain Company, when in use, will be located on or adjacent to track serving elevator and storage bins of this industry.

Red warning lights will be displayed on or adjacent to aerators when machine is in use or fouling track. Trainmen, enginemen and yardmen must be on the lookout for these aerators at all times, and must not pass these machines with engine or cars while red lights are displayed.

**900 (RK-1).** At Sealright Oswego, Inc. Fairfax Industrial District, derails are installed on all four tracks, both sides of lift bridge. Movements on these tracks are governed by indication displayed on dwarf signals on each track. At Owens Corning Fairfax Industrial District derails are installed on the three west tracks both sides of lift bridge. Movements on these tracks are governed by indication displayed on dwarf signals on each track.

## SPECIAL RULES — SECOND SUBDIVISION and BRANCHES

93 (RK). Trains arriving Hastings on Grand Island Branch must stop west of 14th Street until permission is received from train dispatcher to occupy Second Subdivision Main Track.

### Signal Indications

240 (RK). At Belvidere, a westward train receiving approach indication at westward controlled signal, east end of Belvidere MP 208.5, must proceed prepared to stop before any part of train or engine passes the next signal. Trains exceeding 25 MPH must immediately reduce to that speed.

An eastward train receiving approach indication at Signal 2118, must proceed prepared to stop before any part of train or engine passes the next signal. Trains exceeding 25 MPH must immediately reduce to that speed.

### DENVER CUT-OFF DENVER SUBDIVISION

At Limon, Colorado, effective July 8, 1981, in order to effect transfer of cars to and from the Cadillac and Lake City Railroad (C&LK) the following former CRI&P trackage now being operated by C&LK RR is designated transfer trackage.

1. Rock Island Transfer, No. 1 and No. 2 Track.

All cars placed to C&LK RR should be placed into clear on No. 1 Track.

All cars to be pulled will be on No. 2 Track.

2. No. 1 and No. 2 Tracks are each approximately 2,630 feet to clear and hold approximately 45-55 foot cars per track.

3. All trains must not exceed 5 MPH on all C&LK trackage including transfer track.

4. Block signals in C&LK Yard out of service including transfer track.

## SOUTH-CENTRAL DISTRICT

### SPECIAL RULES — ALL SUBDIVISIONS

#### Air Brake Rules

1030 (RSC). Referring to Air Brake Rule 1030 (C) Salt Lake City is a designated inspection point.

## UTAH DIVISION

### SPECIAL RULES—SALT LAKE CITY TERMINAL AREA

#### Use of Engine Bell

30 (RU). Salt Lake City ordinance reads as follows:

"It shall be unlawful for any person or persons employed on a locomotive to fail to ring bell continuously on such locomotive while in motion in the inhabited portions of the city."

30 (RU-1). Whistle Signal (14-I) will not be sounded within Salt Lake City limits unless it is necessary to provide additional warning when visibility is or may be obstructed or that a particular motorist, pedestrian, or employee is unaware of the approach of train and is not responding to other warnings.

#### Joint Operation With Western Pacific

81 (RU). Joint operation of Union Pacific and Western Pacific Railroad is in effect between WP-UP Junction and Smelter, MP 766.4, Second Subdivision. All Second Subdivision trainmen and enginemen and all Salt Lake Yard crews must have a copy of the current Union Pacific-Western Pacific joint pamphlet governing operation between these points while on duty.

#### Movements in Yards

93 (RU). Crews of all trains and engines arriving Salt Lake City must contact Tower yardmaster for instructions to enter yard.

93 (RU-1). All trains and engines moving to North Yard from points south of Fifth North on Passenger Main must stop to clear Fifth North unless movement is authorized by yardmaster.

93 (RU-2). At Salt Lake City, between Second South and Ninth South Street, all trains and engines must proceed prepared to stop short of train, engine, obstruction or switch not properly lined and a speed of 12 MPH must not be exceeded.

Between sunset and sunrise, a flashing yellow light must be displayed at both ends of a car or cut of cars left standing on Fourth West Street.

93 (RU-3). When roll-by inspection is being made by carmen at Fifth North or at Eighteenth North, train or engine movements on adjacent tracks must be stopped.

93 (RU-4). When handling cars from North Yard to South Yard, a member of crew must take position on rear car, lining derail behind cars and applying hand brakes as required by Special Rule 806 (R-1).

#### Use of DRGW Trackage at Salt Lake City

93 (RU-5). While using DRGW tracks, employees will be under supervision of DRGW supervisors, and will be governed by the following rules:

DRGW Rule 11. A train or locomotive finding a fusee burning on or near its track, must stop, then proceed at restricted speed for a distance of one-half mile.

DRGW Rule D-11. A fusee will not apply to the main track upon which train is running if displayed beyond the first rail of adjoining track.

DRGW Rule 12. The explosion of two torpedoes is a signal to proceed at reduced speed looking out for flagman for one and one-half miles and is to be acknowledged by two short blasts of the engine whistle. The explosion of one torpedo will indicate the same as two, but the use of two is required.

DRGW Rule 93. Yard limits will be indicated by yard limit signs and designated in the timetable.

Within yard limits the main track may be used without protecting against other trains or locomotives.

All trains and locomotives must move within yard limits at Restricted Speed, prepared to stop within one-half the range of vision, unless the main track is known to be clear by ABS indication.

Movements against the current of traffic on the main tracks must not be made unless authorized and protected by yardmaster or other designated official.

DRGW Definitions: Restricted Speed — A speed that will permit stopping short of another train or obstruction, but not exceeding 20 miles per hour.

Reduced Speed — A speed that will permit stopping short of another train or obstruction, or anything that may require the speed of a train or locomotive to be reduced.

DRGW Special Rule 17-T. All freight trains, switch and light locomotive movements, including interchange deliveries between UP North Yard, and DRGW Roper will, unless otherwise provided, use the two running tracks extending from DRGW main track, Subdivision 7, between First North Street and North Temple Street to Twenty-First South Street, Roper.

Between crossover leading to WP connection just south of First South Street, Salt Lake City, and Twenty-First South Street, Roper, all trains, switch, light locomotives, and interchange delivery movements will keep to the right. Movements

against the current of traffic will be made only when authorized by yardmaster or on signal indication. Grant Tower operator will obtain authority from yardmaster before positioning signals for reverse movements.

#### DRGW Special Rule 19-N:

Unless otherwise instructed, track assignments S.L.U.D. are as follows:

DRGW Passenger trains ..... Track No. 1  
UP interchange deliveries ..... Any track  
other than No. 1, or as directed by yardmaster.

Trains, yard engines, light engines and others using S.L.U.D. tracks will leave switches as found, except switches will be left lined for No. 3 track. Switch connection with WP main track and S.L.U.D. track just east of First South Street will be left lined for Fence track.

#### DRGW Special Rule 19-S:

Grant Tower annunciator is located 430 feet west of Thirteenth South Street, Salt Lake City. Following whistle signals will be given at this annunciator:

UP light engines, returning — 1 long, 1 short.

**93 (RU-6).** Union Pacific crews entering DRGW tracks at Roper Yard must stop at head-in speaker, Twenty-First South Street, and obtain track on which to yard delivery. After yarding their delivery, they must immediately cut engine off and contact yardmaster in east tower for return movement.

#### Clearances

**97 (RU).** When authorized by train dispatcher and CTC signal indication, yard engine movements may be made in CTC territory between North Yard and Woods Cross without receipt of clearance.

#### Centralized Traffic Control System

**266 (RU).** Yard movements on Passenger Line must not pass Signal 7829 at Eighth South Street until verbal permission is received from dispatcher. When authorized by train dispatcher and CTC Signal indication, yard engine movements may be made in CTC territory between Eighth South Street and Buena Vista on Passenger Line and between Grant Tower and Buena Vista on Freight Line without receipt of clearance.

**275 (RU).** Dual control switch located MP P.799.94 at Second South Street on Provo Subdivision main track Salt Lake City is equipped with color light switch point indicator covering movements over switch.

When switch point indicator displays:

GREEN —switch is lined for Provo main track.

YELLOW —switch is lined for Passenger depot lead.

RED —train and engines must stop and inspect switch points to ensure they are in proper position and fully closed before moving over switch.

Switchpoint indicator will be remote controlled by Train Dispatcher.

#### Switches

**275 (RU-1).** Dual Control Switch located MP P.798.75 between 8th South and 9th South Streets on Provo Subdivision Main Track, Salt Lake City, Utah, is equipped with colorlight switchpoint indicator covering movements of switch.

When switchpoint indicator displays:

GREEN —Switch is lined for Provo Main Track.

YELLOW —Switch is lined for Passenger Main Track.

RED —Trains and engines must stop and inspect switchpoints to ensure they are in proper position and fully closed before moving over switch.

Switchpoint indicator will be remote-controlled by train dispatcher.

#### Movements at Pioneer

**804 (RU).** At Pioneer, engines must not pass south loading rack at Pioneer Pipe building is located at third door from east end of Fry building. Before passing this location with engine or cars, or before coupling to cars on Fry track, an employe in plant must be notified and it must be known that drawbridge is clear for the movement.

#### Handling Cars

**804 (RU-1).** Cars must not be left unattended south of derrails at south end of Passenger Station, Garden or Freight House tracks.

#### Draw Bridge

**900 (RU).** At Fry Roofing, drawbridge between Fry building and Trumbull building is located at third door from east end of Fry building. Before passing this location with engine or cars, or before coupling to cars on Fry track, an employe in plant must be notified and it must be known that drawbridge is clear for the movement.

#### Close Clearances

**900 (RU-1).** Close side clearance exists between Salt Lake Flour Mill and Porter Walton at 500 South 400 West Street, Salt Lake City. Signs are posted.

**900 (RU-2).** Close clearance exists between two business car spurs, south end depot, Salt Lake City. Employes must not stand between these tracks and must not ride on side of cars moving into or out of these tracks.

## SPECIAL RULES — OGDEN

#### Whistle Signals

**14 (RU).** Trains using By-Pass track at Ogden will whistle for 33rd Street crossing and Patterson Avenue crossing.

#### Movement on Yard Tracks

**96 (RU).** Train, engine and yard engine movements may be made without receipt of clearance on signal indication and authority of Wyoming Division train dispatcher between Riverdale, and MP 989.9 and East Riverdale, MP 988.6.

#### Movement of Trains by Block Signals

**240 (RU).** Trains moving in and out of Ogden Union Depot will move on block signal authority, and will not be required to receive proceed signal from switch tender.

**251 (RU).** Between Riverdale and Ogden Union Depot, tracks will be numbered north to south, with northernmost track being No. 1 track and No. 2 track just south of No. 1 track.

On No. 2 track between Riverdale and "End of Block" sign at MP 992.2, Rule 251 is in effect. For westward movement, "End of Block" sign is located to the left of No. 2 track.

**261 (RU).** On No. 1 track between Riverdale and "End of Block" sign at MP 992.2, Rule 261 is in effect. ACS is inoperative for westward movement between Riverdale and MP 992.2.

A westward train stopped by Signal 9909 or 9915, or an eastward train stopped by Signal 9920, 9916 or 9910 must communicate with yardmaster at 30th St., Ogden and be governed by his instructions.

#### Close Clearances

**900 (RU-3).** There is impaired clearance under shed on tracks 7 and 8 at Farmers Mill; tracks 5 and 6 at Globe Mills. Employes must not ride cars while they are being moved under these sheds.

## SPECIAL RULES — FIRST SUBDIVISION and BRANCHES

#### Engine Whistle Signals

**14 (RU-1).** In the State of Idaho, in addition to locations listed in Operating Rule 14 (l), engine whistle must be sounded and bell rung approaching private crossings.

#### Blue Flag Protection

**26 (RU).** At Brigham City, blue flag derail is located approximately 640 feet beyond switch on track to American Greetings Corporation. Removal of blue flag derail must be authorized by American Greetings Corporation.

#### Sidings and Yard Tracks

**105 (RU).** At Cache Jct., westward siding extends from east switch near MP 47.6 to east crossover near cafe. Eastward siding extends from west switch near MP 49.5 to west crossover near cafe.

**105 (RU-1).** At North Yard, First Subdivision trains entering west lead must obtain track number from yardmaster before passing West 16 switch.

#### Movements on Signal Indication

**269 (RU).** Switch at West Bridge Jct., CP 818, to Riverdale By-Pass Track is controlled by Train Disptcher at Salt Lake City. Westward trains from Wyoming 4th Subdivision stopped by signal governing movement over this switch must communicate with train dispatcher at Salt Lake City.

Westward trains from Utah 1st Subdivision en route to Riverdale By-Pass Track must communicate with both the Train Dispatcher at Salt Lake, who will authorize hand operation of dual control switch, and the Train Dispatcher at Cheyenne who will authorize train to proceed.

#### Movement of Trains By Block Signals

**509 (RU).** When a train or engine is stopped by automatic block signals indicating STOP between 23rd Street and Ogden Yard Limits, and such indication does not change promptly to a more favorable indication, a member of the crew must immediately communicate with 30th Street Yardmaster and be governed by his instructions.

When authorized by 30th Street Yardmaster to proceed, train or engine may proceed on route instructed at once at restricted speed to the next signal.

#### Draw Bridge

**900 (RU-4).** At Smithfield in spotting cars between warehouses on Del Monte Corporation Spur, it must be seen that drawbridge between buildings is raised.

## SPECIAL RULES — SECOND SUBDIVISION, PROVO SUBDIVISION and BRANCHES

### Joint Operation With Western Pacific

**81 (RU-1).** Joint operation of Union Pacific and Western Pacific Railroads is in effect between WP-UP Junction and Smelter MP 766.4, Second Subdivision. All Second Subdivision trainmen and enginemen and all Salt Lake yard crews must have a copy of the current Union Pacific-Western Pacific joint pamphlet governing operation between these points while on duty.

### Spacing Trains

**91 (RU).** On Provo Subdivision, between Sandy and Pleasant Grove and between Provo and Lynndyl, trains in the same direction must be kept at least thirty minutes apart, except when closing up at stations.

The crew of the following train will be responsible for trains keeping 30 minutes apart when passed by another train, or before following a train which has been overtaken.

### Block Clearance

**96 (RU-1).** Train and engine movements on IPP Spur will be controlled by train dispatcher through the issuance of block clearances, Form 2643BC, via radio or phone to conductor and engineer of train to be moved. All train and engine movements between MP 0 and MP 8.9 on IPP Spur must be authorized by block clearance, and no portion of track between these points except Offsite siding may be occupied unless conductor and engineer have a valid block clearance in their possession.

All block clearances must be copied by conductor and engineer and must be repeated by each of them to the train dispatcher. Completed time given by train dispatcher must be entered on Form 2643BC, as well as name of person copying block clearance in spaces provided. Train dispatcher must record block clearances in train order book in the following form assigning a train order number to each, preceding it with the letters BC, thus:

BC No 1

Lynndyl to C&E Eng 201

This is your authority to occupy IPP Spur between MP 0 and MP 8.9

Additional instructions - Do not exceed 15 MPH between MP 5 and MP 5.75  
GRJ

R 1247 PM Condr Jones

R 1248 PM Engr Smith

Reported Clear at 215 PM

Proper receipt of block clearance by a train or engine is authority for movement between the first named station and the second named station only. Protection of rear of train as prescribed by Rule 99 is not required in block clearance territory.

When train or engine authorized by block clearance has arrived in clear at destination station, conductor must report arrival to the train dispatcher and enter the time reported on the block clearance. No further movements may be made within block clearance territory without receipt of another Form 2643BC.

When instructed by train dispatcher, conductor must report when clear of intermediate stations and must enter time reported on block clearance form. Train or engine may not reenter that block to the rear without receipt of another Form 2643BC.

Additional instructions such as, "Do not exceed 15 MPH between MP 5 and MP 5.75" or "Report clear of Offsite" must be entered on block clearance as transmitted by train dispatcher. If no additional instructions, the word "NONE" must be entered.

Eastward trains which have been issued block clearance authority for movement between MP 8.9 and Offsite, must unless otherwise instructed, take siding at West Offsite. If necessary to back in, the front of the train must first be protected as prescribed by Rule 99.

Westward trains and engines which have received authority for movement between MP 0. and Offsite, need not take siding at Offsite but must stop clear of the west switch and no movement beyond that point is authorized without the receipt of another Form 2643BC.

Only one train will be allowed in any block at one time, whether following or opposing, and block clearance for a train waiting to move must not be issued until the preceding train has reported clear.

Dispatcher's transfer must include block clearances still in effect.

Except as provided by Special Rule 96 (RU-1) all operating rules remain in effect.

### Centralized Traffic Control System

**267 (RU).** At Milford, eastward and westward trains departing from yard must remain clear of yard lead until dispatcher is contacted and must be governed by his instructions and signal indication.

**267 (RU-1).** At Lynndyl, westward trains or engines must not move from Track 2 to Track 1 at west end of yard without permission from dispatcher.

### Geneva Scale

**804 (RU-2).** At U.S. Steel Yard, Geneva, all trains will enter via track A-1 over weigh-in-motion scale. Engineers of inbound trains must control speed to pull entire train over scale at 3 to 4 MPH. If speed exceeds 5 MPH, spot lights on poles along track and on catwalk at Gate No. 2 will come on, as a signal that speed is excessive, and engineer must immediately reduce speed to 4 MPH.

At U.S. Steel Yard, Geneva, all outbound trains must depart on Track No. A-1. Crossover north of No. 1 Gate road crossing must be used to gain access to Track No. A-1.

All trains must not exceed 5 MPH while moving over U.S. Steel trackage, Geneva.  
**804 (RU-3).** Multiple unit locomotive when using Track A-20 at Geneva must go directly off A-14 lead, and Track A-1 crossover must not be used unless authorized.

### Weigh-in-Motion Scale

**804 (RU-4).** Industry track at Sharp, MP P-700.2, Provo Subdivision has weigh-in-motion scale located 150 feet west of coal loading tipple. Before starting to weigh, scale must be clear of any movement for 90 seconds.

Speed of 3 MPH must not be exceeded over scale and wheels on units must not be allowed to slip or slide while on scale track.

Units and caboose will not clear loading tipple when load-out chute is over track.

### Inspection of Trains

**811 (RU).** Westward Provo Subdivision trains handling coal in cars with friction bearings must stop and inspect such cars at Starr and Lynndyl.

Eastward trains handling ore in cars with friction bearings must stop and inspect such cars between Sharp and Starr.

## SPECIAL RULES — THIRD SUBDIVISION and BRANCHES

### Movement of Trains

**83 (RU).** Before using Fibreboard Spur, trains or engines must first receive authority from train dispatcher.

### Block Clearances

**96 (RU-2).** Train and engine movements on Cedar City Branch will be controlled by train dispatcher through the issuance of block clearances, Form 2643 BC, via radio or phone to conductor and engineer of train to be moved. All train and engine movements on main track between Lund and Cedar City must be authorized by block clearance and no portion of main track between these points may be occupied unless conductor and engineer have a valid block clearance in their possession.

All block clearances must be copied by conductor and engineer and must be repeated by each of them to the train dispatcher and the completed time given by train dispatcher must be entered on Form 2643 BC, as well as name of person copying block clearance in spaces provided. Train dispatcher must record block clearances in train order book in the following form, assigning a train order number to each, preceding it with the letters BC, thus:

BC 1

Lund to C&E Eng 201

This is your authority to occupy Main Track between Lund and Cedar City.

Additional instructions — Do not exceed 20 MPH between MP 8 and MP 8.75  
GRJ

R 1247 PM Conductor Jones

R 1248 PM Engineer Smith

Reported clear at 215PM

Proper receipt of block clearance by a train or engine is authority for movement between the first-named station and the second-named station only. Protection of rear of train as prescribed by Rule 99 is not required in block clearance territory.

When train or engine authorized by block clearance has arrived in clear at destination station, conductor must report arrival to the train dispatcher and enter the time reported clear on the block clearance. No further main track movements may be made without receipt of another Form 2643 BC.

When instructed by train dispatcher, conductor must report when clear at intermediate stations and must enter time reported clear on block clearance form. Train or engine may not re-enter that block to the rear without receipt of another Form 2643 BC.

Additional instructions, such as "Do not exceed 20 MPH between MP 8 and MP 8.75" or "Report clear at Iron Springs" must be entered on block clearances as transmitted by train dispatcher. If no additional instructions, the word "NONE" must be entered.

Only one train may be allowed in any block at one time, whether following or opposing, and block clearance for a train waiting to move must not be issued until the preceding train has reported clear.

Dispatcher's transfer must include block clearances still in effect.

Except as affected by Special Rule 96 (RU-1), Operating Rules remain in effect.

**96 (RU-3).** Train and engine movements on Iron Mountain Branch will be controlled by train dispatcher through the issuance of block clearances, Form 2643 BC, via radio or phone to conductor and engineer of train to be moved. All train and engine movements on main track between Iron Springs and Iron Mountain must be authorized by block clearance and no portion of main track between these points may be occupied unless conductor and engineer have a valid block clearance in their possession.

All block clearances must be copied by conductor and engineer and must be repeated by each of them to the train dispatcher and the completed time given by train dispatcher must be entered on Form 2643 BC, as well as name of person copying block clearance in spaces provided. Train dispatcher must record block clearances in train order book in the following form, assigning a train order number to each, preceding it with the letters BC, thus:

BC 1

Iron Springs to C&E Eng 201

This is your authority to occupy Main Track between Iron Springs and Comstock  
Additional instructions — Do not exceed 15 MPH between MP 5 and MP 5.75  
GRJ

R 1247 PM Conductor Jones  
R 1248 PM Engineer Smith  
Reported clear at 215PM

Proper receipt of block clearance by a train or engine is authority for movement between the first-named station and the second-named station only. Protection of rear of train as prescribed by Rule 99 is not required in block clearance territory.

When train or engine authorized by block clearance has arrived in clear at destination station, conductor must report arrival to the train dispatcher and enter the time reported clear on the block clearance. No further main track movements may be made without receipt of another Form 2643 BC.

When instructed by train dispatcher, conductor must report when clear of west switch of designated intermediate stations and must enter time reported on block clearance form. Train or engine may not re-enter that block to the rear without receipt of another Form 2643 BC.

Additional instructions such as, "Do not exceed 15 MPH between MP 5 and MP 5.75" or "Report clear of Desert Mound" must be entered on block clearance as transmitted by train dispatcher. If no additional instructions, the word "NONE" must be entered.

Only one train may be allowed in any block at one time, whether following or opposing, and block clearance for a train waiting to move must not be issued until the preceding train has reported clear.

Dispatchers transfer must include block clearances still in effect.

Except as affected by Special Rule 96 (RU-2), all Operating Rules remain in effect.

### Clearances

97 (RU-1). When authorized by train dispatcher, yardmaster and CTC signal indication, yard engine movements may be made in CTC territory between Wann and Las Vegas without receipt of clearance.

### Main Track Derails

104 (RU). At Cedar City, spring point derail located in main track just east of MP 31.80 must be locked in derailing position when not being used. Westward trains may trail through derail.

### Derails

104 (RU-1). At Nellis Industrial Park, spur track to serve McDonnell-Douglas derail located 182 feet from switch. Switch crew must stop and determine that no one is on or about cars before throwing derail and coupling to cars.

### Sidings and Side Tracks

105 (RU-2). At Comstock, departure track must be left clear after departure of ore trains.

### Switch Point Indicators

240 (RU-2). Color light switch point indicator governing facing point movements over main track spring switch east Comstock wye switch, MP 10.91, Iron Mountain Branch, displays indications as follows:

- |        |   |
|--------|---|
| Green  | —Spring switch is properly lined for main track movement.   |
| Yellow | —Spring switch is properly lined for turnout movement.  |
| Red    | —Trains and engines must stop and make inspection of switch points to determine if properly lined for movement desired. |

### Centralized Traffic Control System

267 (RU-2). At Milford, eastward and westward trains departing from yard must remain clear of yard lead until dispatcher is contacted and must be governed by his instructions and signal indication.

267 (RU-3). Eastward trains at Caliente must remain clear of public crossing east of depot until authorized to proceed by dispatcher or by signal indication.

267 (RU-4). Eastward freight trains leaving Las Vegas will, unless otherwise directed, use drill track and leave yard at extreme east switch.

### Power Operated Derails

275 (RU-1). Power operated derail on west end of siding, Caliente, operates in conjunction with main track switch.

When necessary to hand operate main track switch or place selector lever in hand position as provided in Operating Rules 275 and 276, derail and selector lever on derail must also be hand operated.

275 (RU-2). Power operated derail on drill track, east end of Las Vegas Yard, operates in conjunction with main track switch. When necessary to hand operate main track switch or place selector lever in hand position, as provided in Operating Rules 275 and 276, derail and selector lever on derail must also be hand operated.

### Handling Cars

804 (RU-4). At Fibreboard, movement must be stopped before entering building. Doors at both ends of plant must be opened before starting movement.

### Leaving Locomotives Unattended

871 (RU). Train or engine crews desiring to eat at Caliente must notify dispatcher as much before arrival as practicable, but not later than east switch ISLEN on westward trains and west switch ETNA on eastward trains.

While crew is eating and train left on siding, engine must be left with air coupled and, in addition, sufficient hand brakes must be applied to keep train from moving but not less than 10 hand brakes must be set on west end of train.

While crew is eating and train left on main track, engine must be left with air coupled, and, in addition, a member of crew, mechanical employe, or road officer must remain on engine at all times.

### High and Wide Cars

900 (RU-5). Nevada Public Service Commission General Order No. 11 covers the operation of cars of excess height and width and of open top cars containing lading of excess height and width.

In addition to Operating Rule 805 (B), the following applies to the operation of such cars:

#### Cars of Excess Height

(1) Freight cars of a height exceeding 15'6" must not be operated except as indicated below:

Freight cars of a height exceeding 15'4" but not greater than 15'6" shall be permanently marked, stenciled or placarded and such marking maintained in a legible condition, reading, "THIS CAR EXCESS HEIGHT."

All such required markings and placarding shall be placed on the side adjacent to the ladder or handholds near the floor line of the car at each of the four corners.

#### Cars of Excess Width

(2) Freight cars of width exceeding 10'10" must not be operated.

Freight cars of a width not exceeding 10'10" may be handled without restrictions or placarding.

#### Cars with Lading of Excess Height or Width

(3) No movement shall be made of open top cars containing lading in excess of 15'6" above the top of rail or extending laterally in excess of 5'5" from center line of car except as hereinafter described:

(4) The operation of cars on which the lading extends laterally in excess of 5'5" from center line of car, shall be restricted to lading the size or dimensions of which cannot be reduced.

(5) All open top cars with lading extending laterally in excess of 5'5" from center line of car or in excess of 15'6" in height above top of rail shall be placarded on the load itself in a conspicuous place when practicable and the car shall be marked, stenciled or placarded, at locations specified in paragraph (1) of this rule.

(6) On any train, the consist of which includes cars loaded as described in the preceding paragraph of this rule, such cars shall be blocked together in one place in the train and if its length permits, they shall be entrained at least 5 cars distant from both the caboose and the engine, provided, however, that the provisions of this subsection shall not apply to the transportation of rail open top cars of highway trucks or trailers, either loaded or unloaded.

#### Notifying Train Employees

(7) A train order shall be delivered to every train containing any car the lading on which extends laterally in excess of 5'5½" from center line of car or in excess of 15'6" in height above top of rail, informing the crew of the train that the train includes such car or cars, stating total number thereof, and advising that no member of the train crew is required to ride on any such cars.

(8) A train order shall be delivered to every train, the operation of which may be affected by the presence or movement of a train containing such wide loads, described in the preceding paragraph of this rule, informing the crew of the train of that fact.

#### Notifying Yard Employees

(9) Yard supervisors shall be given notification sufficiently in advance of the arrival of the cars, the lading on which extends laterally in excess of 5'5½" from center line of car, to enable them to take necessary precautions to safeguard employes in yard.

#### Observance of Cars by Employes

(10) Employes in yards and elsewhere must keep close lookout for wide loads in trains and in switch movements, being on the alert when such movements are passing to avoid hazard of injury from such excess width loads, or damage to equipment.

(11) An employe observing a car of excess height or a car containing lading of excess height or width which is not placarded or stenciled as required by this rule, should notify their supervisor immediately.

(12) Any employe observing a close overhead or side clearance with a car of excess height or a car with lading of excess height or width, should make immediate report so that protection can be given.

The Public Service Commission of the State of Nevada has granted permission for the operation of "High-Cube" cars of a maximum height of 17 ft. from top of rail to top of running board within the State of Nevada.

The following will govern the handling and movement of such cars in Nevada: If train length permits, such cars shall be entrained at least five cars distant from the caboose.

The crew of each train containing freight cars herein authorized to be operated shall be informed by an appropriate train order that the consist of the train includes freight cars of such excess height and that the members of the train crew are forbidden to ride on top of any such cars.

### Air Brake Rules

**1025 (RU).** For movements on Fibreboard Spur, terminal test of air brakes as required by Air Brake Rule 1025 must be made before departing from Apex or Fibreboard.

**1029 (RU).** On passenger trains, running air test as required by Air Brake Rule 1029 must be made at Crestline, eastward and westward.

**1042 (RU).** On westward freight trains departing Crestline, dynamic brake must be placed in service and tested for proper operation between west switch Crestline and east switch Brown.

Retaining valves must be used as follows:

1. All trains from Iron Mountain or Comstock to Iron Springs, all retaining valves.
2. All trains from Desert Mound to Iron Springs, not less than 50% of retaining valves on head end of train.
3. Any train with less than one horsepower effective dynamic brake per trailing ton and averaging more than 75 tons per operative brake, all retaining valves from Islen to Richmond.
4. Any train with less than one horsepower effective dynamic brake averaging less than 75 tons per operative brake, not less than 25 retaining valves on head end of train, from Islen to Richmond.

Any train with less than one horsepower effective dynamic brake per trailing ton and averaging more than 85 tons per operative brake must not exceed 25 MPH Crestline to Farrier. This does not modify the requirements of Paragraph 3 above.

**1042 (RU-1).** Freight trains handled by diesel locomotive with dynamic brake not in operation must use retaining valves as follows:

- Prince to Prince Junction;
- Pioche to MP 30, Pioche Branch;
- MP 27 to MP 22, Pioche Branch.

## CALIFORNIA DIVISION SPECIAL RULES — ALL SUBDIVISIONS

### Markers

**19 (RC).** When operating on ATSF tracks, caboose marker must be lighted day or night.

### Helper Engines

**809 (RC).** When necessary to place a helper engine behind a caboose, not more than two six-axle operating units totaling not more than 179,400 pound tractive effort or not more than two four-axle operating units totaling not more than 135,600 pounds tractive effort or a combination of one six-axle and one four-axle unit totaling not more than 157,600 pounds tractive effort will be used.

When necessary to place two six-axle helper engines or one six-axle and one four-axle engine behind a caboose, helper engineer must not permit current on load meter to exceed 1,050 amps.

Loco. Model	Series	Axles	Rated HP	Approx. Weight Lbs.	Starting Tractive Effort Lbs.	Tractive Effort At 1050 Amps Lbs.
*TR5	1871-1877B	4	1200	247,000	61,750	36,520
GP7	103-126	4	1500	249,000	62,250	55,440
GP9	131-345	4	1750	247,000	61,750	55,440
GP20	474-495	4	2000	258,000	64,500	55,440
GP38-2	2000-2059	4	2000	269,000	67,250	55,440
GP30	700-875	4	2250	260,000	65,000	55,440
GP35	740-763	4	2500	261,000	65,250	55,440
GP40	600-650	4	3000	265,000	66,250	55,440
GP40X	9000-9005	4	3500	274,000	68,500	41,520
SD24	400-448	6	2400	386,000	96,500	83,160
SDP35	1400-1409	6	2500	380,000	95,000	66,600
SD40	3000-3122	6	3000	392,000	98,000	83,160
SD40-2	3123-3808	6	3000	392,000	98,000	83,160
SD45	1-65	6	3600	393,000	98,250	83,160
U28C	2801-2808	6	2800	374,000	93,500	76,000
U30C	2810-2959	6	3000	393,000	98,250	76,000
C30-7	2400-2539	6	3000	395,000	98,750	76,000
DD40X	6900-6946	8	6600	540,000	135,000	88,800

\*Cow-Calf Combination 2400 HP

The foregoing does not modify, in any manner, the requirements of Special Rule 809 (R-7).

### High and Wide Cars

**900 (RC).** California Public Utilities Commission General Order 26-D and Nevada Public Service Commission General Order No. 11 cover the operation of cars of excess height and width and of open top cars containing lading of excess height and width.

In addition to Operating Rules 805 through 805 (C), the following applies to the operation of such cars:

#### Cars of Excess Height

(1) Freight cars of a height exceeding 15'6" must not be operated, except as indicated below:

Freight cars of a height exceeding 15'4" but not greater than 15'6" shall be permanently marked, stenciled or placarded and such marking maintained in a legible condition, reading, "THIS CAR EXCESS HEIGHT."

All such required markings and placarding shall be placed on the side adjacent to the ladder or hand-holds near the floor line of the car at each of the four corners.

#### Cars of Excess Width

(2) Freight cars of width exceeding 10'10" must not be operated.

Freight cars of a width not exceeding 10'10" may be handled without restrictions or placarding.

#### Cars with Lading of Excess Height or Width

(3) No movement shall be made of open top cars containing lading in excess of 15'6" above the top of rail or extending laterally in excess of 5'5" from center line of car except as hereinafter described:

(4) The operation of cars of which the lading extends laterally in excess of 5'5" from center line of car, shall be restricted to lading the size or dimensions of which cannot be reduced.

(5) All open top cars with lading extending laterally in excess of 5'5" from center line of car or in excess of 15'6" in height above top of rail shall be placarded on the load itself in a conspicuous place when practicable, and the car shall be marked, stenciled, or placarded at location specified in paragraph (1) of this rule.

(6) On any train, all open top cars with lading extending laterally in excess of 5'5" from center line of car shall, if train length permits, be entrained at least five cars distant from both the caboose and engine.

On any train, cars on which the lading exceeds 15'6" in height above top of rail shall, if train length permits, be entrained at least five cars distant from the caboose, provided, however, that the provisions of this Subsection shall not apply to

CALIFORNIA DIVISION

CALIFORNIA DIVISION

the transportation of rail open top cars of highway trucks or trailers, multi-level freight cars, either loaded or unloaded, and automobile underframe cars, either loaded or unloaded.

#### Notifying Train Employees

(7) A train order shall be delivered to every train containing any car the lading on which extends laterally in excess of 5'5½" from center line of car or in excess of 15'6" in height above top of rail, informing the crew of the train that the train includes such car or cars, stating total number thereof, and advising that employees are prohibited from riding on any such cars.

(8) A train order shall be delivered to every train the operation of which may be affected by the presence or movement of a train containing such wide loads, described in the preceding paragraph of this rule, informing the crew of the train of that fact.

#### Notifying Yard Employees

(9) Yard supervisors shall be given notification sufficiently in advance of the arrival of the cars on which the lading extends laterally in excess of 5'5½" from center line of car, to enable them to take necessary precautions to safeguard employees in yard.

#### Observance of Cars by Employees

(10) Employees in yards and elsewhere must keep close lookout for wide loads in trains and in switch movements, being on the alert when such movements are passing to avoid hazard of injury from such excess width loads, or damage to equipment.

(11) Any employe observing a car of excess height or a car containing lading of excess height or width which is not placarded or stenciled as required by this rule, must notify their supervisors immediately.

(12) Any employe observing a close overhead or side clearance with a car of excess height or a car with lading of excess height or width, must make immediate report so that protection can be given.

The following conditions will govern the handling and movement of high cube cars of a maximum height of 17 ft. from top of rail to top of car in California and Nevada.

1. The crew of each train containing freight cars herein authorized to be operated shall be informed by an appropriate train order that the consist of the train includes freight cars of such excess height and that members of the train crew are forbidden to ride on top of any such cars.

2. Any yard crew required to handle freight cars herein authorized to be operated shall be notified by its supervising officials of the presence of such cars in said yard.

3. Appropriate instructions shall be issued to all road and yard crews forbidding them to ride on the top of the cars herein authorized to be operated.

## SPECIAL RULES — FIRST SUBDIVISION and BOULDER CITY BRANCH

#### Clearances

97 (RC). When authorized by train dispatcher, yardmaster and CTC signal indication, yard engine movements may be made in CTC territory between Las Vegas and Bracken without receipt of clearance.

#### Derails

104 (RC). On Boulder City Branch, eastward trains must stop at Stop sign, MP 21.76, and line spring point derail before proceeding. After being used, derail must be restored to derailing position.

104 (RC-1). Derail installed on west leg of wye, Boulder Jct.

#### Trailer Ramp Facilities

104 (RC-2). At Las Vegas, rail clamps are used at trailer ramp facility. Engine foremen must know rail clamps are removed before attempting to pull or spot cars at this location.

#### Power Operated Derails

275 (RC). At east end of Las Vegas yard, west end of siding Kelso and east end R.D. Lead Yermo, power operated derail on drill track operates in conjunction with main track switch. When necessary to hand operate main track switch or place selector lever in hand position, as provided in Operating Rules 275 and 276, derail switch and selector lever on derail switch must also be hand operated.

#### Location of Cars in Train

809 (RC-1). On westward trains between Cima and Kelso, all empty flat cars must be entrained near rear of train.

#### Inspection of Trains

811 (RC). When a westward freight train stops at any station between Cima and Kelso, trainmen from front and rear of train must make such walking inspection of train as time will permit, but must be at engine or caboose when train is ready to proceed. Rule 811 (A) will not apply.

#### Train Unattended

871 (RC). Train or engine crews desiring to eat at Kelso must notify dispatcher as much before arrival as practicable, but not later than at Chase on westward trains and Balch on eastward trains.

While crew is eating and train left on siding, engine must be left with air coupled and, in addition, sufficient hand brakes must be applied to keep train from moving but not less than 20 hand brakes must be set on west end of train.

While crew is eating and train left on main track, engine must be left with air coupled and, in addition, a member of crew, mechanical employe, or road officer must remain on engine at all times.

#### Close Clearances

900 (RC-1). At Kelso, when cantilever or ramp located about middle of track 5 is in loading position it will not clear box or other high type car and will not clear person on side or top of car. Switching must not be done on track 5 when ramp is down in loading position. A support 6 feet wide is located between tracks 4 and 5 and care should be exercised when passing.

#### Movable Bridge

900 (RC-2). At Blue Diamond, movable bridge is in service at Flintkote Co. across Track 3 near Door 12.

A red signal on light near switch to Track 4 indicates bridge is lowered across track. When this indication is displayed no movement may be made beyond the light, nor may cars on Track 3 be coupled to or moved. When bridge is clear of track a green light will be displayed.

#### Air Brake Rules

1029 (RC). Running air test as required by Air Brake Rule 1029 must be made by passenger trains at:

Cima — Eastward and westward.

1042 (RC). On descending grades from Cima to Kelso and from Blue Diamond to Arden the following applies:

Train exceeding 3500 tons must not be controlled exclusively with dynamic brake.

Retaining valves must be used:

1. On any train exceeding 85 tons per operative brake.

2. On any train exceeding 80 tons per operative brake with less than two horsepower effective dynamic brake per trailing ton.

3. Any train with less than one horsepower effective dynamic brake per trailing ton. Such trains must not exceed 15 MPH Cima to Kelso and must stop and remain standing ten minutes at Dawes to cool wheels.

4. On all westward trains, dynamic brake must be tested between MP 309 and MP 292.

Conductor must advise engineer number of cars in train, total tonnage, and tons per operative brake.

From Cima to Kelso, train not required to use retaining valves may operate at a speed not to exceed 25 MPH provided speed can be controlled with minimum brake pipe reduction (6-8 lbs.). If more than minimum brake pipe reduction (6-8 lbs.) is required to control speed, a speed of 20 MPH must not be exceeded.

Maximum speed of westward trains over crest of grade at Cima must be 10 MPH less than maximum authorized speed Cima to Kelso.

Between Kelso and MP 217.6, westward trains exceeding 75 tons per operative brake and which do not have at least one horsepower effective dynamic brake per trailing ton, must not exceed 30 MPH at any point.

In cases where a train is required to stop between Cima and Kelso, provisions of Air Brake Rule 1044 will govern.

## SPECIAL RULES — SECOND SUBDIVISION and BRANCHES

#### Whistle Signals

14 (RC). Engine whistle signal 14(l) must be sounded before entering Abex yard at Spadra.

#### Classification Signals

21 (RC). Southern Pacific extra trains need not display white classification lights between Bartolo and Puente Junction.

#### Use of Engine Bell

30 (RC). Within corporate limits of cities named below, engine bell must be rung continuously when engine is moving:

Riverside Ontario Pomona Los Angeles

The use of engine whistle and bell must be minimized while moving through cities on the Anaheim and San Pedro Branches.

#### Movements on Yard and Other Tracks

93 (RC-1). Employees performing service on Harbor Belt Line Railroad will be governed by Union Pacific Operating Rules and Special Instructions.

93 (RC-2). Trains or engines enroute to bulk loader, San Pedro and Long Beach, must obtain authority from UP train dispatcher before entering SP trackage MP 21.4 or MP 21.6 San Pedro Branch. Switch must be restored to normal position after movement is completed. A speed of 5 MPH must not be exceeded through turnouts to SP.

Trains or engines returning to UP tracks at these locations must obtain authority from train dispatcher before re-entering UP tracks.

93 (RC-3). Before starting yard movement in either direction between Santa Fe Avenue and Olympic Boulevard, member of crew must ascertain from tower yardmaster that there are no conflicting movements in the area.

Yard movements on two parallel tracks between Santa Fe Avenue and crossover between 14th and 15th Streets must use track to the right in direction of movement. Cars must not be left standing on these tracks when to do so would interfere with normal yard movements.

Eastward movements must stop at Stop sign at Santa Fe Avenue near dividing switch in red and green side and ascertain that there are no conflicting movements in or out of Butte Street Yard before proceeding.

93 (RC-4). At L. A. Junction Yard, before fouling lead or adjacent tracks, member of crew must receive authority from L. A. Junction yardmaster.

93 (RC-5). Southern Pacific and Union Pacific operate jointly over Anaheim Branch between Colima Jct. and Fullerton Jct., under provisions of Rule 93.

Between Fullerton Jct. and Anaheim, assigned hours of operation are as follows:

SP crews — 12:01 A.M. to 11:59 A.M.

UP crews — 12:01 P.M. to 11:59 P.M.

If necessary to use main track between Fullerton Jct. and Anaheim outside of assigned hours, movements must be protected as prescribed by Rule 99.

UP trains must obtain permission from SP Los Nietos train dispatcher before occupying SP-UP joint track between Colima Jct. and Fullerton Jct. SP train dispatcher must be notified when movement leaves SP-UP joint track. If unable to communicate with SP train dispatcher, UP train dispatcher Salt Lake City must be contacted for instructions.

### Junctions

98 (RC). Trainmen on engines entering or leaving spur track at North Main Street, Los Angeles, must communicate with towerman at Mission Tower, who will release electric lock on derail.

98 (RC-1). For movement of UP trains and engines to and from Glendale Branch at Arroyo Jct., Dayton interlocker must be notified to handle switch.

### Maintenance of Way Flagging — San Pedro Branch

99 (E-RC). When track is impassable or before obstructing track or in any way rendering it impassable or unsafe, flagman must be immediately sent in both directions with flagman's signals.

One-fourth mile from point to be protected, flagman must place a red flag by day or red light by night between the rails of the track or on the right side of the track as viewed from an approaching train. After coming to complete stop, train or engine must not proceed until proper verbal information as to cause for the red signal is received, or a proceed signal given with a yellow flag by day or yellow light by night is received, or written instructions are found with the red signal.

In vicinity of obscure curves or if other conditions make it such that visibility approaching the red signal is less than one-fourth mile, flagman must proceed with an additional red flag by day or red light by night until visibility is at least one-quarter mile.

Maintenance of Way forces using this rule in performing maintenance work must have an operable radio with correct channel.

### Derails

104 (RC-3). On Glendale Branch, derail located on main track just below run-around switch at Glendale.

104 (RC-4). At Crestmore, before switching cars into Track 1 and Track 2 at Riverside Cement Corporation, a member of crew must ascertain that derails on these tracks are in derailing position. If derails are not in derailing position, a member of crew must contact Packhouse foreman or lead man.

### Tracks Other Than Main Tracks

105 (RC-1). Between CTC Stop signals vicinity MP 3.8 and CTC Stop signals vicinity MP 7.7, there is no main track. Rule 105 governs.

Maximum authorized speed between these locations is 20 MPH. Except between MP 5.7 and MP 7.7 Eastward trains on track 3, 40 MPH.

Before leaving departure yard, eastward trains or engines must receive authority from Crest Tower yardmaster.

### Movement on Signal Indication

240 (RC). Eastward trains departing East Yard and Track 3, (known as Rubber Lead), will be governed by signal indications.

Trains or engines must not enter this track at any hand operated switch between MP 5.72 and MP 7.7 without authority from Crest yardmaster, who must in turn receive authority from train dispatcher.

Rule 516 and Special Rule 516 (R) apply at all hand operated switches between MP 5.72 and MP 7.7.

### Dual Control Switches

275 (RC-1). Whistle activated dual control switches are in service on San Pedro Branch at Thenard.

For movements to and from Long Beach Harbor, advance switch point indicators and horn receivers to activate switches are located as follows:

Westward — MP 21.15

Eastward — Thenard connection on south side of Foot St.

Dual control switch is located at MP 21.35 and is equipped with color light switch point indicators.

When switch point indicator displays:

GREEN: —Switch is lined for San Pedro Main Track.

YELLOW: —Switch is lined for Long Beach Harbor.

RED: —Trains and engines must stop and examine switch points to insure they are in proper position and fully closed before moving over switch.

For movements to and from Los Angeles Harbor, advance switch point indicators and horn receivers to activate switches are located as follows:

Westward — MP 21.45

Eastward — MP 21.65

Dual control switch is located at MP 21.50 and is equipped with color light switch point indicators.

When switch point indicator displays:

GREEN: —Switch is lined for San Pedro Main Track.

YELLOW: —Switch is lined for Los Angeles Harbor.

RED: —Trains and engines must stop and examine switch points to insure they are in proper position and fully closed before moving over switch.

If switch is not lined for desired route, it will be necessary to sound blast of engine whistle prior to passing horn receiver. If necessary, to hand operate switch, instructions will be posted in box located near switch.

### Interlocking

605 (RC). The following whistle signals will be used to indicate route:

Hobart:

For east wye .....	0
From San Pedro main track to ATSF siding .....	0
From ATSF siding to San Pedro main track .....	0
From UP transfer to ATSF siding .....	000
From ATSF siding to UP transfer .....	000

At Mission Tower, one long sound of towerman's emergency whistle is a signal for all movements within interlocking limits to stop at once and not move until proper signal or definite information is received from towerman.

609 (RC). When a train or engine is stopped by an interlocking signal at Signal Bridges 3, 4 or 6, between Dayton Avenue and Mission Tower and signal does not change to proceed indication, a member of crew must communicate with towerman at Dayton Avenue or Mission Tower.

609 (RC-1). At Bell, in performing switching between home and approach signals, cars must not be left standing on clearance section of track located between 350 feet west of eastward home signal and 330 feet east of westward home signal. Switching movements may be made between these points and approach signals without interfering with operation of Southern Pacific.

At Bell, when making movements from siding or Bethlehem Steel Corporation spur to main track, trainmen must be governed by track occupancy indicator. If track occupancy indicator displays unoccupied indication, switch may be thrown and when dwarf signal displays proceed indication, movement will be made at restricted speed. When performing switching at those points, flag protection must be provided for cars left on main track between home signals.

When making movements to and from Bethlehem Steel Corporation spur to siding, switch nearest train must be lined first to make contact for governing signal.

609 (RC-2). Home signal at east end Los Angeles River bridge at Redondo Tower governs westward movements over ATSF spur track crossing at west end of bridge.

Color light dwarf signal at west end of Los Angeles River bridge governs westward movements over ATSF main track crossing at Redondo Tower.

### Colton Yard

803 (RC). Union Pacific crews working in SP Colton Yard will work under the supervision and instructions of Colton yardmaster. Following Southern Pacific rule applies:

SP Rule 825 — Colton: When trains or cars are left standing in Colton Yard, a sufficient number of hand brakes must be set on the east end to properly secure cars.

Not less than six hand brakes must be set on the east end when trains or cars are left standing except when less than six cars, all hand brakes must be set. Such brakes must be securely applied using standard brake club to set staff brakes.

When necessary to release hand brakes to move portion of the cars the same number of brakes must be set on remaining cars. This also applies to cars set out on 9th Street Interchange.

All movements on yard tracks Colton must be made with caution, not exceeding 15 MPH.

### Switching on Commercial Carriers Trackage, Montebello

804 (RC). Tracks at Commercial Carriers facilities have capacity of five 85-foot cars each to clear gate. There is heavy descending grade from main track to gate. Before attempting to place cars at this location, movement must stop on main track and must remain standing on main track until gate is opened.

Due to close clearance created by curvature and long cars, west track (right hand track entering from main track) must, when practicable, be spotted first.

### Switching Movements

804 (RC-1). At Tube Sales Co., East Los Angeles, all movements must stop before entering building.

804 (RC-2). Los Angeles Terminal area has a great number of curves in excess of 16°, and before switching freight cars 85 feet or more in length into industry tracks, it must be known that the curvature is less than 16°.

804 (RC-3). At Pomona, within the confines of General Dynamics property, cars must not be cut off while in motion.

804 (RC-4). At the Norman J. Fox Industries, Vernon, stop signs have been installed on each side of Track 35, between buildings, to protect removable bridge across this track.

Movement must be stopped before passing stop signs and member of crew must ascertain that bridge is removed and track is clear before proceeding.

804 (RC-5). At Paramount, within the confines of Monsanto property, cars must not be cut off while in motion.

804 (RC-6). At Pacific Press, Vernon, flashing red light has been installed to protect removable bridge.

Movement must be stopped before passing red light and member of crew must ascertain that bridge is removed and track is clear before proceeding.

#### Retarder Yards

804 (RC-7). At East Los Angeles, hump repeater signals are located on the north side of Track No. 1 at MP 5.75; on west end of Freight House at MP 5.9; and on the east end of Freight House at MP 6.1.

These signals govern movements of hump engines only and are two-way signals, facing both east and west and will repeat signals given at the hump crest.

#### Location of Cars in Train

809 (RC-1). On westward trains between Summit and San Bernardino, all empty flat cars must be entrained near rear of train.

#### Close Clearances

900 (RC-3). Sign reading "Trains Must Not Operate Beyond This Sign" is located 877 feet west of switch to Novak Scrap Yard, Champagne Spur; no train or engine movement may be made beyond this sign. All cars must be left east of sign.

900 (RC-4). At Sears Roebuck, 5525 So. Soto Street, moveable bridges are in service at warehouse doors 8 and 11, which may extend over warehouse track and foul lead track. Bridges are equipped with oscillating red lights when extended.

Two indication signal is located on warehouse platform roof inside gate at Soto Street. When red indication is displayed, tracks are fouled, and all movements must stop until bridges have been retracted and green signal is displayed.

900 (RC-5). At UniRoyal Company, 5675 Telegraph Road, moveable bridge may extend over track serving receiving dock. Two indication signal is located on face of building. A red signal indicates bridge is extended over track, and when this indication is displayed, movements must stop before passing the red signal and must not proceed until bridge has been retracted and green signal is displayed.

900 (RC-6). At Continental Can, 5556 Grace Place, portable loading dock has been installed. Sign reading "DANGER — Portable Dock Must Be Removed Before Moving Train." Red light indicates dock is in place. Green light indicates dock has been removed.

900 (RC-7). At Walnut, Benton Feed Yard has portable barrier with sign reading "DO NOT PASS BEYOND THIS POINT — EMPLOYEES WORKING."

If necessary to switch beyond this location, employe of Benton Feed Yard must be requested to remove barrier.

## NORTHWESTERN DISTRICT

### SPECIAL RULES — ALL SUBDIVISIONS

#### Engine Whistle Signals

14 (RNW). In addition to locations listed in Union Pacific Operating Rule 14 (I) and Consolidated Code Operating Rule 15 (I), engine whistle must be sounded and bell rung approaching private crossings when view of crossing is obscured or when it can be seen that persons or vehicles are approaching or in the vicinity of the crossing; and in the State of Washington when crossing is a travelled road or street.

#### Switch Lights

27 (RNW). Switch lights will not be used on branch lines.

Where switch lights are not used, trains and engines must approach facing point switches prepared to stop if switch is not in normal position.

#### Train Order Signals

222 (RNW). On branches, except Twin Falls and Yellowstone Branches, lights will not be kept burning at night in train order signals. Trains must be governed by day indication of such signals.

#### Power Operated Derails

275 (RNW)

Idaho Div'n. — East and West Glenns Ferry and West Nampa

Oregon Div'n. — East Portland Interlocking, CP 189, CP 188 and BN Interlocking at Spokane

At the above locations the derails operate in conjunction with the main track switch. When necessary to hand operate either the derail or the switch, Operating Rules 275 and 276 apply.

#### Handling Hazardous Materials

713 (RNW). In Oregon each train transporting hazardous materials must be equipped with at least two radio transmitter receivers which are in good working order and compatible with each other.

In addition, trains over 2000 ft. in length which are transporting hazardous materials must be equipped with hand set radio in good working order. This hand set must be capable of communicating with the required transmitter receivers.

If the required radio equipment fails to function properly while train is enroute, train may proceed to the next point of crew change where the equipment must be replaced or repaired.

713 (RNW-1). Cars containing hazardous materials placarded "Explosives A" or "Flammable Gas" set out at stations at which no carmen are on duty, must be visually inspected by train crew making the set-out prior to crew's departure, and must be visually inspected by train crew picking up such cars prior to train's departure.

713 (RNW-2). ORS 761.395 in connection with transportation of hazardous materials in the State of Oregon reads as follows:

"761.395. Visual external inspections required on cars standing in rail yards or stations more than two hours. Each railcar containing hazardous materials and bearing an 'Explosives A' or 'Flammable Gas' placard as required by federal regulation, and which remains in a rail yard or station for more than two hours, shall be visually inspected externally by the transporting railroad within two hours of the car's arrival and within two hours prior to the car's departure."

As part of the implementation of the visual inspection requirements of ORS 761.395, the required inspections, if no car man is on duty, shall be made by a member of the train or switch crew at each yard or station where the affected rail cars are to be picked up, set out, or where a movement of a train containing affected rail cars terminates or originates. The person making the inspection shall ascertain whether there is any evidence or signs of leakage or other loss or change of contents from any affected rail cars and whether there are any obvious defects in the running gear of any affected rail cars. The dispatcher shall be immediately notified of all problems observed which are not promptly corrected.

804 (RNW). In addition to cars containing hazardous materials listed in Appendices 12 and 13, the following cars are not to be humped, and must be set out, or set to no-hump track, or shoved to rest in bowl track: Missiles — Cars placarded Radioactive — Transformers — Loaded depressed center flat cars — Modular house units — Shiftable open-top loads.

#### Position Of Cars In Train

809 (RNW). Open-top cars containing pumice, chips, sand or other commodities subject to blowing off cars must, when practicable, be entrained not less than ten cars ahead of caboose. Cars containing one of these commodities should be separated from cars containing another of these commodities by three cars, to avoid contamination.

## IDAHO DIVISION

### SPECIAL RULES — ALL SUBDIVISIONS

#### Engine Whistle Signals

14 (RI). In the State of Idaho, in addition to locations listed in Operating Rule 14 (I), engine whistle must be sounded and bell rung approaching private crossings.

### Public Crossings

14 (RI-1). At Shoshone, Glens Ferry, Ontario, Mt. Home and Pole Line Rd. (Pocatello) whistle detectors mounted on orange colored whistle posts have been installed near main crossings.

All eastward trains must sound whistle before passing whistle posts. **Exception:** At Glens Ferry both eastward and westward trains must sound whistle.

103 (RI). In the State of Idaho, public crossings must not be blocked longer than 15 minutes.

## SPECIAL RULES — POCATELLO TERMINAL AREA

### Use of Whistle and Bell and Crossing Protection

14 (RI-2). At Pocatello, whistle signal 14 (I) must be sounded for fire road crossing in Montana freight yard and engine bell must be ringing approaching and passing over this crossing.

14 (RI-3). At Pocatello, engine bell must be ringing approaching and passing over crossing entering PFE Repair Shop, crossing entering Purina Plant and approaching and entering Store House.

14 (RI-4). At Pocatello, whistle detector located on orange colored post installed at MP 135.8, Fourth Subdivision, just west of Pole Line Road crossing, eastward trains must sound whistle before passing this post. When an eastward train is stopped at this location, a member of the crew must protect Pole Line Crossing before proceeding.

### Movements In Yard

93 (RI). North or westward running track extends from switch to No. 1 Main Track East End Pocatello Yard to Pocatello Jct.

Unless otherwise authorized by the yardmaster, all train and engine movements on this track must be made with the current of traffic.

93 (RI-1). No. 1, No. 2 and No. 3 main tracks between Pocatello Junction and MP 213.1 are signaled for ABS two main track operation.

No. 3 main track extends from east end Pocatello yard to Pocatello Jct.

Current of traffic is westward on No. 1 main track and eastward on No. 2 main track.

Authority must be obtained from yardmaster before occupying main tracks and before movement is made against the current of traffic.

Eastward Begin CTC sign is located at Stop Signal at MP 213.1.

Westward Begin CTC sign is located at Stop Signal at Pocatello Jct. on Nos. 1, 2, & 3 main tracks.

93 (RI-2). All trains or engines must not foul leads or running tracks at either end of Receiving Yard until authority is received from yardmaster.

93 (RI-3). Westward trains arriving Pocatello on No. 1 main track must stop clear of crossover located at MP 213.3 leading from No. 1 main track to Receiving Yard, unless otherwise instructed by yardmaster or dispatcher and those directed to use main track must stop at fueling station at west end of Depot, unless otherwise instructed by yardmaster or dispatcher.

Eastward trains on main track must stop at fueling stop sign located at MP 213.0 opposite Bowl Tracks, unless otherwise instructed by yardmaster or dispatcher.

When an eastward train is ready to leave Departure Yard, a member of crew must so advise the train dispatcher.

93 (RI-4). Speed over weigh-in-motion scale must not exceed 3 MPH.

93 (RI-5). At Pocatello engine house, brakeman must precede multiple unit back up movements on foot from entering switch at west end. Power must not couple into other power already on Engine House Track.

### Road Crossings

103 (RI-1). At Pocatello, engines or cars must not be left standing on fire road crossings and these crossings must not be blocked longer than necessary when making switching movements.

At Pocatello, on Old Montana main track, all trains and engines must approach Oak Street not to exceed 15 MPH and be prepared to stop if crossing is occupied.

### Drawbridge

240 (RI). Block signal indication on Alley track may be changed only by contacting Meadow Gold foreman to have drawbridge raised.

### Retarder Yard — Pocatello

804 (RI). Switching movements handled by Car Retarder System are controlled by signal indications and verbal instructions over radio or loud speakers.

Hump signal, located at crest of the hump, governs eastward movements on hump lead. Hump signal repeaters repeat the same indications displayed by the hump signal. The indications of these signals are as follows:

Color	Indication
Red	—Stop.
Yellow	—Proceed (toward hump) not exceeding 3 MPH.
Green	—Proceed (toward hump) not exceeding 6 MPH.
Flashing Red	—Back up (away from hump).

Trimmer signal, located at crest of the hump, controls westward movements from west end of classification yard. Trimmer signal repeater repeats the same indica-

tions displayed by the trimmer signal. The indications of these signals are as follows:

Color	Indication
Red	—Stop, and do not proceed except on instructions from hump yardmaster.
Green	—Proceed.

Hump and trimmer signals are controlled by yardmaster, engine foreman or other designated employee.

An air whistle located on the compressor building will be controlled from hump yardmaster's office and Tower A. The following whistle signals will be used:

1 long blast — Humping operations are about to start.

2 short blasts — Call for maintainer.

3 short blasts — Call for section foreman.

804 (RI-1). Cars must be left 3 car lengths to clear clearance point at east end of Bowl tracks.

804 (RI-2). Referring to second paragraph Rule 804 (E) and to Rule 869. At Pocatello, an employe must ride rear of multiple unit engine backing up without cars.

### Restricted Cars

805 (RI). West end of Academy tracks and a number of tracks in shop area and Bucyrus Erie Plant have curves in excess of 16 degrees.

805 (RI-1). Trains or engines handling loads in excess of 12 ft. 6 ins. wide must not operate on north running track adjacent to Departure 13 when Departure 13 is occupied.

## SPECIAL RULES—FIRST SUBDIVISION and BRANCHES

### Engine Whistle Signals

14 (RI-5). Referring to Rule 14 (I): Within the State of Wyoming, duration of complete whistle signal approaching public crossings must be not less than twenty seconds.

### Block Clearance

96 (RI). Train and engine movements on Dry Valley Branch will be controlled by train dispatcher through the issuance of block clearances, Form 2643-BC, via radio to conductor and engineer of train to be moved. All trains moving on main track between Epco and Dry Valley must be authorized by block clearance and must not occupy any portion of main track without a valid block clearance in their possession.

All block clearances must be copied by conductor and engineer and must be repeated by each of them to the train dispatcher and the repeated time given by train dispatcher must be entered, as well as name of person copying block clearance. Train dispatcher will record block clearance in train order book in the following form, assigning a train order number to each, preceding it with the letters BC thus:

BC 1

Epco to C&E Eng 201

This is your authority to proceed from Epco to Dry Valley.

Additional instructions — Do not exceed 20 MPH between MP 8 and MP 8.75.

TSD

R 1247 PM Conductor Jones

R 1248 PM Engineer Smith

Dispatcher's transfer must include block clearances still in effect.

Proper receipt of block clearance by a train or engine is authority for movement from the first named station to the second named station only. Protection of rear of train as prescribed by Rule 99 is required only when a reverse movement is to be made in block clearance territory. When train or engine authorized by block clearance has arrived in clear at destined station, conductor must report arrival to the train dispatcher and enter the time reported clear on the block clearance. No further main track movement may be made without receipt of another block clearance.

Additional instructions such as "Do not exceed 10 MPH between MP 12 and MP 13" or for a movement from Dry Valley to Epco may state "May pass Wooley Valley", must be entered on block clearance as transmitted by the train dispatcher. If no additional instructions, the word "NONE" must be entered.

Only one train may be allowed in any block at one time, whether following or opposing, and block clearance for a train waiting to move must not be issued until the preceding train has reported clear. Except as affected by Special Rule 96 (RI) all operating rules remain in effect.

### Block Rules

240 (RI-1). Applies to dwarf signal entering Amoco and Chevron off the Cumberland Branch, Kemmerer Branch.

At Amoco when a train or engine is stopped by a Stop signal and no conflicting movement is evident, a member of the crew must immediately communicate with Amoco employee via telephone located next to the signal and be governed by signal indication.

At Chevron all movements must be governed by signal indication.

### CTC Rules

269 (RI). Switch at west end Idaho Division siding at Granger (MP 1.58) is controlled by train dispatcher at Cheyenne.

Eastward trains stopped by Stop signal governing movement over this switch must communicate with train dispatcher, Cheyenne, as required by Rule 269.

Westward trains stopped by Stop signal governing movement over this switch must communicate with both the train dispatcher at Cheyenne, who will authorize hand operation of switch when necessary, and train dispatcher at Pocatello, who will issue Form C Clearance when required.

### Switching Operations

**804 (RI-3).** At Opal, on El Paso Natural Gas Company tracks:

Before coupling to cars spotted at loading rack on either side, such cars must be walked and it must be known that all loading connections have been removed and clear.

Before coupling to cars on these tracks, it must be known that all cars are properly secured by hand brakes so that car or cars will not roll if coupling fails to make.

Engines must not go beyond end of loading rack and at least two cars, when available, must be held onto.

**804 (RI-4).** Crews using North runaround track 600 ft. east of river bridge at Ink-om Cement Plant, watch out for hazard of falling into coal pit.

### Long Cars

**805 (RI-2).** Town track, Montpelier has curve of 18 degrees.

### Hand Brakes

**806 (RI).** At Montpelier 5 hand brakes must be set on west end of cars left on any track in west yard.

### Track Restrictions

**899 (RI-1).** Units must not be operated on following tracks:

Conda	Loading tracks west of scales.
Epcó	Over rollover dumper over track scales.
Monsanto Spur	End 50 ft. of Furnace Room Track.
Leefe	Over scales on North Track at Tipple
Dry Valley	Under ore loading Tipple.
Inkom	Over track scales at Cement Plant.

### Crossing Signals

**900 (RI).** On Monsanto Chemical Plant Track No. 4, near Furnace Building, hand activated crossing signals have been installed. Train movements will receive a red signal until push button located on signal mast is activated. After truck traffic is stopped, signal will display lunar to proceed across crossing.

## SPECIAL RULES — SECOND SUBDIVISION and BRANCHES

### Public Crossings

**103 (RI-2).** At Burley, and Rupert city ordinance prohibits engines, cars or trains standing on any street crossing so as to interfere with street traffic for longer than five minutes.

**103 (RI-3).** On Ketchum Branch, at MP 68.24, trains and engines must stop clear of Baldy Mountain Ski Lift crossing before proceeding.

### Sidings and Side Tracks

**105 (RI).** At Fairfield, trains must not pass west switch of stock track until it has been ascertained that cars from Wendell Mill are clear of main track.

### Restricting Trains

**215 (RI).** At Rupert, Burley and Twin Falls when a train order is issued restricting a train at that station for an opposing movement, operator need not place torpedoes as required by Rule 215. This does not modify other requirements of this rule.

### Track Scales

**804 (RI-5).** At Don, movements over weigh-in-motion scale, west end rock track, Simplot Plant, must not exceed 10 MPH.

### Warning Device

**804 (RI-6).** Warning Device at J. R. Simplot Co. at Heyburn and Burley Processors at Burley must be actuated by a crew member before switching at these plants is commenced.

### Long Cars

**805 (RI-3).** Following tracks have curves in excess of 16 degrees:

Don — J. R. Simplot Ampo-Phos trackage 20 degrees;  
Oakley — Team track 20 degrees: — Mill track 21 degrees.

### Track Restrictions

**899 (RI-2).** Units must not be operated on the following tracks:

Don UP crews must not move engine or cars east of FMC Plant main crossing on load tracks or west of empty track switches on empty track.

Engines must not be operated over trackage serving J. R. Simplot Ampo-Phos, Bagging and Bulk Plant. Engines must not pass under loader on Foster Slag Track No. 1, account insufficient clearance.

Starrhs Ferry

Do not move engines or cars over scale or under overhead building at Coors Warehouse.

Myers

Engines must not enter covered area at TASCó bulk sugar loading plant or covered area at wet hopper.

McMillan

Engines or boxcars must not enter covered area at wet hopper at TASCó factory.

### Air Brakes

**1029 (RI).** With passenger trains, running test as prescribed in Air Brake Rules 1029, 1029 (B) and 1029 (C) must be made before descending grade at Ticska.

## SPECIAL RULES — THIRD SUBDIVISION and BRANCHES and BOISE CUT-OFF

### Inspection of Track

**101 (RI).** At Emmett, trains and engines using log spur and chip track in Boise-Cascade Mill Yard must inspect crossing and know that flange ways are clear before passing over them.

### Public Crossings

**103 (RI-4).** At Emmett, running switches or permitting cars to run free over Washington Street crossing is prohibited.

**103 (RI-5).** At Nyssa cars left on siding must be left clear of Oregon P.U.C. markers at Locust Ave.

**103 (RI-6).** At Boise Freight engines moving across crossings must have an employe riding leading deck of engine protecting movement.

**103 (RI-7).** At Ontario, all movements on Tokyo 1 and 2, East Team, and East Warehouse tracks over 5th and 6th Avenue crossings must be protected by a member of crew ahead of movement.

### Restricting Trains

**215 (RI-1).** At Emmett, when a train order is issued restricting a train at that station for an opposing movement, operator need not place torpedoes as required by Rule 215. This does not modify other requirements of this rule.

### Long Cars

**805 (RI-4).** Curvature on following tracks is in excess of 16 degrees:

Perkins	Zellerbach spur	20 degrees.
Nampa	Carnation spur	18 degrees.
Fairgrounds	Track 2	17 degrees.
Boise Freight	Coast track	20 degrees.
	Coast Pass	17 degrees.
	B&W track	17 degrees.
	Team track lead	17 degrees.
	Nehi track	20 degrees.
Vernon	Gate City Steel track	17 degrees.
Caldwell	South Mill track	20 degrees.
	Swift's Spur	18 degrees.
Payette	Payette Branch main track MP 0.25	17 degrees.

### Track Restrictions

**899 (RI-3).** Units must not be operated on the following tracks:

Fisher	Engines must not go beyond either the wet hopper or unloading hoppers on old track near main track at TASCó factory.
Simplot (Wilder Branch)	Over under-track pit at Simplot Soil Builder.
Nyssa	At TASCó factory beyond stock chute on tracks 2 and 3 and Beet Track 3, coal silo trestle.
Rubicon (New Meadows Branch)	On New Logging Spur beyond end of heavy rail 1600 ft. from switch Boise-Cascade trackage, west of No. 1 Receiving Track, west switch.

### Air Brake Rules

**1029 (RI-1).** With passenger trains, running test as prescribed in Air Brake Rules 1029, 1029 (B), and 1029 (C) must be made before descending grade at Reverse.

**1046 (RI).** On Idaho Northern Branch, eastward trains handled by engine without dynamic brake or without pressure maintaining in operation must stop at MP 64 not less than 10 minutes to cool wheels and inspect train.

## SPECIAL RULES — FOURTH SUBDIVISION and BRANCHES

### Movements In Yards

**93 (RI-6).** At Idaho Falls, all train movements must not exceed 5 MPH over switches on lead at west end of yard from scale crossover to and including No. 5 track.

### Railroad Crossing

**98 (RI).** At Silver Bow movements over Burlington Northern and Milwaukee

main tracks are governed by Automatic Interlocking signals. Push button located on signal house may be operated to obtain signal indication.

#### Crossings

103 (RI-8). Idaho Falls, before crossing Yellowstone Highway at the following locations, highway crossing signals must be activated:

Cliff St. (Old Montana Main)  
Short St. (Ice Spur Lead)  
19th St., Texaco Oil Spur (Gravel Spur)  
West Broadway St. (Taube Spur)

Starter boxes are located on cases or masts on each side of highway crossing. A crew member must use switch key to activate signals before making each movement onto or over highway crossing. Switch key may then be removed and signals will continue to operate until movement has cleared the crossing. Signals must not be activated except when movement is to be made onto or over the crossing.

At Anderson St. highway crossing, if crossing signals are inoperative, block signals on either side of the crossing will indicate stop. After stopping, whistle must be sounded to activate highway crossing signals.

#### Sidings and Side Tracks

105 (RI-1). Trainmen and enginemen must expect to find cars on the following tracks at all times:

Ucon	—siding	Gibson	—siding
St. Anthony	—West Belt siding	Wapello	—siding
Hart	—siding	Cotton	—siding
Rexburg	—siding	Bassett	—siding
Payne	—siding	Barrett	—siding

#### Restricting Trains

215 (RI-2). At Idaho Falls and Dillon, when a train order is issued restricting a train at that station for an opposing movement, operator need not place torpedoes as required by Rule 215. This does not modify other requirements of this rule.

#### Long Cars

805 (RI-5). Referring to Rule 805 (D). Curvature on following tracks in excess of 16 degrees:

Collins	American Potato spur	20 degrees.
	Idaho Starch Factory spur	20 degrees.

#### Use of Hand Brakes

806 (RI-1). At Gay, cars set out must have slack bunched and not less than five hand brakes set on low end of track and not less than two hand brakes set near middle of cut on each track.

#### Position of Cars in Train

809 (RI). On West Belt Branch any loaded car with gross weight in excess of 263,000 pounds must be separated from units or any other car with a gross weight exceeding 177,000 pounds by at least 3 cars having less than 177,000 pounds gross weight each.

On West Belt Branch cars in excess of 240,000 pounds gross weight must not be handled between Menan and St. Anthony.

On Mackay and Aberdeen Branches cars in excess of 263,000 pounds gross weight must not be handled, and cars in excess of 220,000 pounds gross weight must not be handled between Arco and Mackay.

#### Track Restrictions

899 (RI-4). Units must not be operated on the following tracks:

Idaho Falls	Coal Yard Trestle on Agren Spur.
Divide	Coal trestle.

#### Air Brake Rules

1042 (RI). Trains from Gay must not be controlled exclusively by dynamic brake. Dynamic brake must be tested prior to passing MP 18.0. On trains from Gay, if dynamic brake is inoperative, retaining valves positioned in heavy holding must be used on all cars. Special Rule 1042(R) and 1044 apply.

When handling ore with single unit from Gay to MP 9, consist must not exceed 40 cars.

## OREGON DIVISION

### SPECIAL RULES ALL SUBDIVISIONS

#### Helper Engines

809 (RO). On Oregon Division Special Rule 809 (R-6) and 809 (R-7) are modified as follows:

On freight trains, when helper units are to be cut into train, helper sets of two or less units must be placed ahead of caboose. Helper sets with more than two units will be placed ahead of the tonnage of those additional units. Double units will be considered as two units in application of this rule.

When a train is stalled on main track and it is necessary to place helper units behind caboose, authority to do so must be obtained from train dispatcher or company officer and in all cases maximum of two units will be used and remaining units of consist must be isolated. When shoving on caboose in this manner, rear end employes will ride in cab of helper units.

### SPECIAL RULES — FIRST and SECOND SUBDIVISIONS and BRANCHES

#### Main Track Derails

104 (RO). Main track derails are located at the following points:

Pilot Rock — two derails located as follows: 1500 ft. east of east switch to New Set-out Track and 190 ft. east of west switch to Old Mill Track.

#### Switches

104 (RO-1). At LaGrande switches at both east and west end yard track No. 2 must be lined and locked for main track No. 1 when not in use.

#### Helper Engines

809 (RO-1). When helper units are cut out of trains at Kamela or Encina, helper units will be used to couple rear portion of the train to head portion.

Communication via radio between road engineer and helper engineer must be maintained at all times, when possible, while handling trains with helper units to coordinate starting, accelerating, negotiating, slowing and stopping procedures. Road engineer being the engineer in charge, must inform helper engineer of throttle settings on head end and helper engineer will correspond accordingly. Helper engineer when increasing or decreasing throttle should, when practicable, be two throttle notches above that of road engineer in order to control slack.

When starting trains with helper on rear end of train, and it is not possible to communicate signals, the following method will be used:

When ready to move, engineer on head end will make a 15-pound automatic brake pipe reduction, return brake valve to running position and wait three minutes. Engineer on helper engine will start three minutes after his gauge shows brake pipe pressure being restored.

#### Close Clearances

900 (RO). At LaGrande, look out for close clearance between Tracks 4 and 5, which have 13 ft. track centers creating less than normal clearance.

#### Air Brake Rules

1029 (RO). With passenger trains, running test as prescribed in Air Brake Rules 1029, 1029 (B) and 1029 (C) must be made before descending grades as follows:

Encina	—westward and eastward;
Telocaset	—westward and eastward;
Kamela	—westward and eastward.

1042 (RO). At Encina, Telocaset and Kamela, speed of all trains over crest of grade must be 5 MPH less than maximum authorized speed on descending grades.

1042 (RO-1). On descending grades from Encina to Durkee, from Kamela to Hilgard and from Kamela to Huron, the following applies:

Trains must be handled with a brake pipe reduction of not less than 6 pounds. Retaining valves must be used:

1. On any train exceeding 85 tons per operative brake.
2. On any train exceeding 80 tons per operative brake with less than TWO horsepower effective dynamic brake per trailing ton.
3. On any train with less than ONE horsepower effective dynamic brake per trailing ton. Such trains exceeding 80 tons per operative brake must not exceed 15 MPH.
4. On any train being handled without pressure maintaining.

1042 (RO-2). On descending grades from Encina to Quartz or from Telocaset to Union Jct., the following applies:

Trains exceeding 85 tons per operative brake must not exceed 25 MPH.

Train must be handled with not less than 6 pound brake pipe reduction.

Retaining valves must be used:

1. On any train exceeding 100 tons per operative brake and having less than one horsepower effective dynamic brake per trailing ton.
2. Any train being handled without pressure maintaining.

## SPECIAL RULES HINKLE TERMINAL

### Handling of Switches

**104 (RO).** Racor 22 switches located at west end and east end of departure tracks, may be run through by trains departing Hinkle Yard only, except when snow and ice conditions exists, switches must be lined by hand and switch points inspected.

**104 (RO-1).** Switch to hump setout track, when opened, will set hump signal to red indication (STOP). Movement to setout track must be controlled by either hand signal or radio communications. To return to humping operations, setout track switch must be returned to normal and reset button on console pressed to clear signals.

**104 (RO-2).** All switches off hump pullback track must be lined and left for hump lead except when changed for immediate use. All movements on hump lead must be authorized by yardmaster.

**104 (RO-3).** Derails located immediately outside of enginehouse, both east and west ends, are not to be removed for movement into the enginehouse until permission is received from enginehouse foreman immediately prior to the movement, and it must be ascertained that blue flags have been removed and employees are in the clear and warning whistle must also be sounded.

### Signal Indications

**240 (RO).** Switching movements handled by car retarder system are controlled by signal indications and verbal instructions over radio or loud speakers.

Hump Signal located at crest of the hump governs eastward movements on hump lead. Hump signal repeaters repeat the same indications displayed by the hump signal. The indications of these signals are as follows:

Red	— stop.
Yellow	— proceed toward hump not exceeding 3 MPH.
Green	— proceed toward hump not exceeding 8 MPH.
Flashing Red	— back up away from hump not to exceed restricted speed.
Red over Lunar	— trim clear.

Engines must not pass hump signal unless lunar indication received or move authorized by hump yardmaster.

Trimmer signal located at crest of the hump controls westward movements from west end of classification yard. Trimmer signal repeater repeats the same indications displayed by the trimmer signal. The indications of these signals are as follows:

Red	— stop and do not proceed except on instructions from hump yardmaster.
Green	— proceed.

Hump and trimmer signals are controlled by yardmaster, engine foreman or other designated employe.

A warning device located near group retarders will be controlled from hump yardmaster's office and when activated will indicate hump operations are about to begin.

**240 (RO-1).** Shove signals located at east end of departure tracks will control shove movements into east end of departure tracks as follows:

Lunar	— clear to shove.
Red	— stop, track is full.

When track is full, trim foreman's control console will show constant red light on track selector button and audible warning buzzer will sound for five seconds. Shove movement must be stopped. Any further movement must be governed by instructions from yardmaster.

Emergency stop switch on trim foreman's control console, when activated, will set shove signals to stop.

**240 (RO-2).** Fixed signals located at MP 187.3, east end receiving yard tracks 3, 4 and 5, are shown with lunar indication. This is the most restrictive indication that can be given by these signals.

**240 (RO-3).** Rules 240(A), 240(P) and 241(B) as contained in Union Pacific Operating & Maintenance of Way and Signal Rules books, effective May 1st, 1972, apply at MP 186.3 and MP 185.1, 6th Sub-Division in yard limits. When stopped at these locations, tower yardmaster must be contacted before proceeding from these locations.

### Power Operated Derails

**275 (RO).** At CP 189 and CP 188, power operated derails operated in conjunction with dual control switches on Main Track No. 1 and Main Track No. 2, Departure Lead, and Receiving Lead. When necessary to hand operate or place selector lever in hand position as provided in Operating Rules 275 and 276, derail switch and selector lever on derail switch must also be hand operated.

### Dual Control Switches

**276 (RO).** Power controlled crossovers and switches operated by trim foreman and hump foreman must be properly lined for route to be used with corresponding indication on control panels prior to any movement being started or allowed to pass over these switches. Control switches are not to be re-positioned immediately ahead of approaching movements and must not be re-positioned until entire movement clears track circuit as indicated on control panels. In the event a red indication is shown on control panels or there is not a light burning in switch point indicator, these switches must be placed in hand operation before movement is allowed to pass over these switches, and yardmaster must immediately be notified of malfunction. In the event of electrical failure, switches must be hand operated and locking features on switch must not be engaged until power is restored and indica-

tion of switch's position on control panel is in correspondence with actual position of switch in field.

Hump foreman must see the following switches when not in immediate use are positioned and pinned on control panel as follows: Switch No. 2 — lined for power lead; Switch No. 9 — lined for receiving No. 5.

### Electric Lock Switches

**280 (RO).** Electric lock switches are at the following locations: Crossovers from Main Line No. 1 to Main Line No. 2 at MP 186.1 and MP 187.2, and controlled by Mountain Dispatcher.

Hand operated switches are located on Main Line No. 1 at MP 184.1, MP 184.4 and MP 184.8, and crossovers from Main Line No. 1 to Main Line No. 2 at MP 185.5, and controlled by Sandy dispatcher.

### Movement in Yard

**803 (RO).** All trains before departing Hinkle Yard and all engines before departing Enginehouse must contact hump yardmaster and be governed by his instructions.

**803 (RO-1).** Westward trains arriving Hinkle on East Departure Lead to the Departure yard must contact Trim Foreman when reaching "END OF BLOCK" sign and receive acknowledgement that power controlled switches are properly lined for westward movement before passing east set of power controlled crossovers on Departure Lead.

### Switching Cars

**804 (RO).** The following cars are not to be humped or allowed to roll free. They must be placed to no-hump track or bowl track as directed by tower yardmaster: LP gas — missiles — atomic material — transformers — modular housing units — loaded depressed center flat cars — cars in excess of 40 tons per axle — hazardous material as outlined in Appendices 12, 13 and 14.

**804 (RO-1).** Cars must not be left closer than three car lengths from clearance point at east end of bowl tracks.

**804 (RO-2).** During trimming operations trim foreman will run track list through TIS system and special attention given to see hazardous material is properly placed and physical lineup of track is the same as shown on list and any discrepancies or changes must be reported to terminal yardmaster.

**804 (RO-3).** Employees must ride rear of multiple unit engine backing up except engines making backup movement on hump pullback lead.

**804 (RO-4).** Trim engines making movements from class tracks or departure yard must not foul lead without engineer obtaining authority from trim foreman. Trim foreman giving authority for movement will be responsible for protection.

**804 (RO-5).** When shoving coupled cars, if there is any doubt as to whether or not track will hold all cars without fouling switches or leads, employe responsible for movement will contact tower yardmaster and be governed by his instructions.

### Speed Restrictions

Main Track No. 1; 40 MPH/40 MPH.

Main Track No. 2, MP 182.0 to MP 184.4; 70 MPH/70 MPH.

Main Track No. 2, MP 184.4 to MP 189.2; 60 MPH/50 MPH.

Departure Leads, East and West; 40 MPH after rear of trains have departed makeup track.

Weigh-In-Motion Scale; dead rail 15 MPH.

### Radio Rules

**662 (RO).** Engineer will be responsible for making verbal response acknowledging receipt of radio communications to signals or instructions given by radio and employes giving those signals or instructions must insure that communications have been received and understood.

### Safety Instructions

Safety Instructions 4013 contained in Form 7908, UNION PACIFIC RAILROAD Rules Governing Duties and Department of Employees, Safety Instructions and Use of Radio, effective October 1, 1974, reads as follows:

4013. The wearing of hard hats is required of all employees in the Mechanical, Maintenance of Way, Signal, Stores and Communications departments except office personnel, and by all employes when entering designated hard hat area.

Conductor pilots, when working with Maintenance of Way locomotive cranes and other work equipment will be required to wear hard hats. Work train crews will be required to wear hard hats when outside of the caboose or locomotives when working with Maintenance of Way employes. The Maintenance of Way supervisor in charge of work trains or work equipment will furnish trainmen with hard hats.

Switchmen working as hostler helpers will be required to secure hard hat from enginehouse supervisor and will be responsible for wearing hard hat in designated hard hat areas, returning hard hat to enginehouse supervisor at the end of shift.

## SPECIAL RULES — THIRD AND FOURTH SUBDIVISIONS AND BRANCHES

### Use of Engine Whistle

**14 (RO).** At The Dalles, between Union Ave. and Madison Ave., it is unlawful to sound engine whistle except to signal flagman or to prevent accident not otherwise avoidable.

### Crossings

103 (RO). At MP 84.16, between Amtrak Depot and Union St. grade crossing at The Dalles, a sign reading "Amtrak Stop Here" and bell detector to activate crossing protection for Union St. have been installed.

Eastward Amtrak trains must sound bell on engine for 15 seconds before proceeding eastward. This will activate the signal protection at Union St. However, engine bell must be sounded within 40 feet of sensor to accomplish this.

If consists of trains are such that engine bell is in excess of 40 feet from the sensor, engineer must proceed gradually until contact is made with track circuit and engineer must know that crossing gates are down before proceeding over Union St.

### Derails

104 (RO-4). Main track derails are located at the following points:

Condon (MP 44.0)  
Heppner (MP 44.9)  
Umatilla (40 feet west of Johns Manville spur.)

### Movements Against Current of Traffic

151 (RO). At the Dalles, whenever movement is made against the current of traffic on westward main track, any other westward movement must be held at block signal 88.9 and when any movements are being made against the current of traffic on eastward main track, any other eastward movement must be held at Crates until advised that the main track is clear.

### Signal Indications

267 (RO-2). At Castle, when signal governing movement to Carty Industrial lead displays proceed indication, movement is authorized on lead in either direction without flag protection.

If signal fails to display proceed indication, movement on lead must be authorized by Form C Clearance, which must be copied by a member of crew, repeated to train dispatcher and delivered to engineer.

### Centralized Traffic Control

269 (RO). Push buttons are located in relay houses:  
West Biggs MP 184.0 MP 184.5

### Power Operated Derails

275 (RO). At Castle, power operated derail on Carty Industrial Lead operates in conjunction with dual control switches providing access to Lead. When necessary for a movement entering Lead to hand operate switches or place selector levers in hand position as provided in Operating Rules 275 and 276, derail switch and selector lever on derail switch must also be hand operated.

### Electric Locked Switches

280 (RO). At Oregon Trunk Jct., junction switch and both switches of crossover between eastward and westward main tracks are equipped with electric locks controlled by operator at The Dalles. Telephone is located at crossover switches.

Proceed indication on Signal A-951 is authority for trains from Bend Branch to proceed on westward track to The Dalles without receipt of clearance.

### PGE Carty Plant

900 (R). The following applies when operating units through PGE Carty Plant rotary car dumpers:

Maximum speed on the coal loop track will be 5 MPH.

Locomotive units equipped for RCS operation must not be moved through dumper as antenna associated with RCS equipment will not clear dumper.

Train must be stopped before entering dumper to close side windows and awnings on all units in consist.

Conductor must obtain authority from dumper operator before proceeding through dumper.

A stop-and-go signal will be installed on the south end of the dumper building and this signal must display a yellow aspect before proceeding. In addition a verbal signal from the conductor located in the dumper operator's office by radio must be received before moving train into dumper building.

All Union Pacific cabooses except bay window-type cabooses must be cut off before proceeding through dumper as Union Pacific cupola-type cabooses will not clear dumper; hand brake on caboose must be applied.

Members of crews on units must remain entirely inside of units while unit moving through dumpers unless otherwise instructed, rear end crew should remain in vicinity of caboose and perform roll-by inspection as train passes.

### Air Brake Rules

1042 (RO-3). Retaining valves must be used on descending grades as follows: Condon Branch, all westward trains, MP 35 to MP 16, all retaining valves must be used. And on all loads retaining valves must be placed in heavy holding position.

## SPECIAL RULES — ALBINA TERMINAL

### Movements in Yards

93 (RO-1). The following instructions govern while using trackage of Portland Terminal Railroad:

On Depot Yard Tracks 1 and 2, a member of the crew must precede all movements over crossing in front of Station and Baggage Room unless a proceed signal is given by an authorized person.

93 (RO-2). Two parallel tracks between East Portland and Albina are designated as:

Main track 1 — track nearest river;

Main track 2 — track farther from river.

These tracks are signalled for movement in both directions.

Trains or engines must receive authority from West Tower yardmaster to line switches to Track 1 or 2 for movement to East Portland or before fouling No. 2 Running Track and must then be governed by block signal indication.

When returning to Albina yard all switch engines must notify operator at East Portland after clearing Harding St.

### Switches

104 (RO-5). When units are moved into or out of roundhouse, it must be known that all switches are relined for the lead after use.

### Dual Control Switches

275 (RO-1). At Union Pacific controlled interlockings, listed below, when control operator is unable to clear the signal and movement is authorized as prescribed by Rule 609 (a) or 609 (b), levers on control machine must, when possible, be positioned for route to be used.

Selector level on all dual control switches over which movement is to be made must be placed in HAND position and must not be restored to POWER position until movement over the switch has been completed.

East Portland

Portland Terminal

### Switching Operations

804 (RO-12). Cars must not be shoved ahead of engine through tunnel between St. Johns Jct. and Peninsula Jct.

804 (RO-13). At Terminal 4, when Cargill switch engine is tied up on Elevator 7 or this track is blocked by Cargill Company's motor vehicles, Elevator 9 must be used for switching movement west of the elevator.

804 (RO-14). The Toyota Auto Facility in the Terminal 4 area, consists of five (5) tracks, numbered Zone 8 Tracks 31-32-33-34-35, and a derail exists on the west end of each rail. ALL cars handled to or from this facility must be handled WITH AIR CUT IN AND OPERATING. All cars spotted to this facility must have handbrakes set before detaching motive power.

When handling cars TO this industry it must be understood that not more than FIVE (5) cars will be handled when ENTERING (Zone 8 Tracks 31 through 35), and these cars must be handled in compliance with Operating Rule 804(B).

When pulling loads FROM this industry, movement will not exceed TEN (10) cars.

804 (RO-15). 85 foot cars must not be placed in Track New 2 at Terminal 4.

### Track Restrictions

805 (RO). At the following locations, 85-foot rail trailer flat cars may be handled on curves in excess of 16 degrees as provided therein:

Between Albina and east end of Steel Bridge, Portland;

Between East Portland and east end of Steel Bridge, Portland. 85 foot trailer flat cars must not be placed on Northern Specialty spur.

805 (RO-1). At North Portland area, Union Pacific equipment must not be operated on tracks other than tracks 101, 102, 103 and 104.

### Close Clearances

900 (RO-1). At south end of Union Station, Portland, clearance is very close and will not clear a man on side of car between tracks 1 and 2, 3 and 4 from interlocking signals to point 100 feet north of the crossing.

900 (RO-2). Cars or loads of excess height or width must not be placed under shed on Rip tracks 1, 2 or 3, under load shifter or inside Freight House, Albina.

### Air Brake Rules

1025 (RO). On arrival Portland air brakes on westward Amtrak trains must be left applied on engine and cars.

## CONSOLIDATED CODE SPECIAL RULES — FIFTH SUBDIVISION AND BRANCHES

### Standard Time

2 (RO). Employees listed below must have a railroad grade watch with correct time while on duty:

All employes in train, engine or yard service.

All employes whose duties require them to handle train orders or to record or report the arrival, departure or passing of trains except when assigned in office where a standard clock is located. Such other employes as may be designated.

3 (RO). At Black River operators will be governed by Union Pacific Operating Rule 3 (B) which is:

At stations where there is no standard clock, operators must compare time with the train dispatcher as soon as practicable after commencing each day's work, but before making time comparisons with other employes.

When Maintenance of Way or Signal Department employes subject to time service rules do not have access to a standard clock, they must, when practicable, compare time with operator or train dispatcher, before starting each day's work.

#### Fusees

11 (RO). First sentence of Consolidated Code Rule 11 is modified as follows: A train or engine finding a fusee burning red on or near its track must stop before passing the fusee and then proceed at reduced speed for one mile.

#### Reduce and Resume Speed Signs

12 (RO). Reduce Speed sign, showing the maximum speed permitted in miles per hour, placed to the right of the track as viewed from an approaching train, indicates that the track 2,500 feet distant is in condition for a speed not greater than that shown on the sign. Resume Speed sign, placed to the right of the track as viewed from an approaching train, indicates the end of the Reduce Speed location.

Where two speeds are shown, the higher speed applies to passenger trains, the lower speed to freight trains. Where one speed is shown, it applies to all trains.

Indicated speed must not be exceeded until entire train has passed Resume Speed sign.

Such speed restrictions will also be shown in the timetable.

#### Protection of Track Work

12 (RO-1). When reflectorized yellow, yellow-red or green signs are displayed as required by Rule 12 or Rule 14 of the Consolidated Code of Operating Rules, display of lights of corresponding colors at night is not required.

14 (RO-1). On lines operated by the Union Pacific Rule 14 (A) of the Consolidated Code of Operating Rules is modified as follows:

A train or engine finding a red flag or a red light displayed between the rails of the track or to the right of the track as viewed from an approaching train must stop before any part of the train or engine passes the red signal and must not proceed until a proceed signal given with a yellow flag or a yellow light is received, verbal permission is received, or written instructions are found with the red signal.

When a red flag or red light is found within the limits prescribed in Form Y order, a train or engine must not pass the red signal without stopping.

The red signal must be replaced when found between the rails.

12, 14 (RO-2). On those portions of track operated by Union Pacific Railroad, note to Rules 12 and 14 of the Consolidated Code of Operating Rules, Edition of 1980, does not apply and trains and engines must not increase speed until entire train has passed a green flag displayed to the right of the track.

#### Tri-Radial Lights

17 (RO). Revolving amber light on locomotives so equipped must be burning both day and night as follows:

On road engines when engine is moving, except on trailing units in multiple consists;

On yard engines when moving in a street and when approaching and passing over any public or private crossing.

#### Headlights

17 (RO-1). Where reflectorized switch lamps or targets are in use, in case of headlight failure at night, trains and engines must approach facing point switches at restricted speed except where automatic block signals are in service.

81 (RO). On Burlington Northern tracks the Consolidated Code of Operating Rules apply and on Union Pacific tracks the Consolidated Code of Operating Rules as well as current Timetable and Special Instructions govern.

#### Yard Limits

93 (RO-3). At Albina, Oregon Fifth Subdivision crews will be governed by Consolidated Code of Operating Rules except that Union Pacific Rule 93 will apply. See Special Rule 93 (R).

#### Railroad Crossings

98 (RO). At a railroad crossing at grade protected by signals, trains, engines or cars must not be left standing between the opposing home signals unless length of consist extends beyond one of those signals.

#### Flag Protection

99 (RO). Prescribed distance is one and one-half miles on Union Pacific Railroad.

#### Train Orders

200 (RO). The first sentence of Consolidated Code Rule 200 is modified as follows: Train orders will be issued over the signature of the train dispatcher and such signature must be placed directly under the last word of the order.

Balance of the rule is unchanged.

212 (RO). Time in body of train orders must be stated in words and figures. In transmitting and repeating train orders, time must be spelled out and then pronounced, example: "t-w-o t-e-n 2-1-oh PM".

215 (RO). Except at initial stations, when a train's superiority is restricted for an opposing train at the point where the order is issued to it, the order must not be made complete to the train which is being advanced until the operator has placed two torpedoes on the rail not less than 1000 ft. from the train order signal in the direction of the restricted train, and the train dispatcher has been notified that torpedoes have been placed. In addition, the restricted train must be brought to a stop by operator, using red flag or red fusee, before the train dispatcher OK's the clearance.

#### Forms of Train Orders

226 (RO). On lines operated by the Union Pacific the following is substituted for Form Y of the Consolidated Code of Operating Rules:

#### Protection of Gangs or Machines

ON \_\_\_\_\_ AT FOLLOWING

(SUBDIVISION) (DATE)

LOCATIONS ALL TRAINS MUST PROCEED AT RESTRICTED SPEED UNLESS PROPER VERBAL INFORMATION IS RECEIVED FROM FOREMAN IN CHARGE OR PROCEED SIGNAL GIVEN WITH YELLOW FLAG OR YELLOW LIGHT IS RECEIVED

WHILE PROCEEDING AT RESTRICTED SPEED TRAINS MUST BE PREPARED TO STOP SHORT OF MEN AND MACHINES ON OR FOUL OF TRACK

Time From To	Tracks Affected	Between MP and MP	Foreman's Name	Location of yellow/red sign when other than prescribed distance/location
--------------	-----------------	-------------------	----------------	--

Trains receiving this order must proceed within the designated limits between the times shown as the order directs.

A train within these limits at the time the order becomes effective must proceed as the order directs until rear of train has passed beyond the limits designated in the order.

Train being governed by Form Y order receiving verbal authority to proceed, or proceed signal given with yellow flag or yellow light, may then proceed at normal speed unless otherwise restricted.

#### General Description of Signals

Stop signals are designated by the absence of number plates and may also be marked by a plate bearing the letter 'A'.

#### Authorizing Extras and Sections

250 (RO). When movement is entirely within territory where Rule 251 or Rule 261 is in effect, sections and extra trains may be authorized by Clearance Form A, instead of by train order or numbered clearance, except that work extras must be authorized by train order in Rule 251 territory.

Clearance for a section must bear the words "Green signals" or "No signals" following section number. When clearance bears the words "Green signals" it requires the display of green signals to the terminal station of that train on that subdivision.

#### Centralized Traffic Control System

267 (RO-3). Clearance Form C must be received to authorize track and time limits for a work train. Clearance Form C must also be received to authorize a train or engine to proceed from a Stop indication as provided in Operating Rule 269 except when movement is leaving main track or leaving CTC territory or movement is entirely within yard limits.

268 (RO). When a train or engine clears a controlled siding by use of an auxiliary track or branch line, a member of crew must report to control operator when controlled siding is clear and switches properly lined. Train or engine must not re-enter controlled siding without authority from control operator.

269 (RO-1). In CTC territory, when flagging from a Stop signal in accordance with Rule 269, train or engine must not pass next point of communication except on signal indication or further authority from control operator.

**Exception: This does not apply between Black River and Fife, Fifth Subdivision.**

#### Dual Control Switches

275 (RO-2). Except as provided in Rule 276, a train or engine must not make a reverse movement, or a forward movement after making a reverse movement, over a dual control switch, except on signal indication, or with permission from control operator.

275 (RO-3). When necessary to perform switching over dual control switch as provided in Operating Rule 276, first move, when possible, must be made on signal indication.

275 (RO-4). When communication fails and it is necessary to hand operate dual control switches, switch must not be operated until five minutes after selector lever has been placed in HAND position.

#### Block Signals

509 (RO). When a slide warning device plug is found pulled or controller operated but no obstruction on or damage to track is found, the plug must be replaced, if practicable, or controller reset by depressing "Re-set" button, and conductor must make report to train dispatcher by quickest means of communication.

513 (RO). Referring to exception (a), Rule 513: Indication displayed by a track occupancy indicator (block indicator) is not authority for a train or engine movement, nor does it relieve a train or engine from waiting five minutes before fouling a main track.

516 (RO). Rule 516 of the Consolidated Code of Operating Rules is cancelled and the following will apply:

When a train or engine is to enter a siding or yard track at a point where the switch to be used is not more than 500 ft. beyond an automatic block signal displaying Stop or Stop-and-Proceed indication, it may pass such signal without stopping, provided the switch and derail are set for the movement and proper hand signal is received from trainman or yardman, but the movement must be made at restricted speed.

**Exception:** This rule does not apply at a signal which governs movement over a dual control switch.

**517 (RO).** If a block signal fails to display its most restrictive indication when a block is occupied or when a switch connected with automatic block signal system is changed from its normal position, it must be regarded as displaying a Stop indication. A member of the crew must be left at signal and he must stop all trains moving in the direction governed by that signal and inform them of false-clear indication. Flagman must remain there until relieved by an employe of Signal Department or by instructions from proper officer.

In all cases, train dispatcher must be notified by the quickest means of communication.

#### Safety Precautions

**700 (RO).** Employes must not step on the coupler or drawbar of any car, or on any portion of cushioning devices.

**711 (RO).** Union Pacific train dispatcher must be advised in advance of any known condition that will delay the train or prevent it from making usual speed.

**713 (RO).** When leaving initial station or intermediate stops, speed must be such as will permit trainmen to safely board the train until train has moved one train length or it is known that all members of the crew are aboard.

**713 (RO-1).** Flat spots on wheels are condemnable as follows:

On locomotive, two inches or longer;

On freight car, two and one-half inches or longer, or if there are two or more adjoining spots each two inches or longer;

On passenger train cars, one inch or longer.

When such flat spots are discovered, conductor or engineer must immediately report them to the train dispatcher.

**726 (RO).** Caboose, outfit cars or other cars which contain stoves with fire burning, must be placed in yards or at stations where the danger of fire is minimized to the greatest extent practicable. Such cars must not be left unattended on bridges for extended periods of time.

#### Restricted Cars

**800 (RO).** When conductor takes charge of a train, he must determine if any cars or units are restricted as to speed and promptly advise engineer and dispatcher of any such speed restriction. The engineer will be held equally responsible with the conductor in the event the conductor fails to notify the engineer and engineer does not ascertain this information.

#### Position of Cars in Trains

**805 (RO-2).** Scale test cars (except cars WO-3, WO-4, WO-5 and UP 903006) and cars tagged, stencilled, or billed 'Handle Only At Rear End of Train' must be handled in rear of train with scale test car next to caboose.

**805 (RO-3).** Referring to Rule 805 (E), Consolidated Code of Operating Rules:

Open top cars or flat cars loaded with pipe, lumber, poles or other lading which has a tendency to shift, must not be handled in train next to engine or caboose or next to trailers on flat cars, or multi-level or flat cars loaded with autos, machinery or other lading subject to damage should the load shift. This does not apply to containers or trailers on flat cars except to flat bed or stake-body trailers loaded with similar commodities.

**805 (RO-4).** Automobiles, trucks, tractors, modular housing units and similar lading subject to damage by abrasion, loaded on flat cars or multi-level auto racks must be entrained not less than five cars behind the engine. If practicable, such cars must be entrained ahead of open top cars containing coal, coke, sand, pumice or other abrasive materials. If this cannot be done such cars must be entrained not less than five cars behind any open top car containing abrasive material.

**805 (RO-5).** Snow plows handled in freight trains must be handled next ahead of caboose. Snow plows with only one drawbar may be handled behind caboose when securely chained to caboose and with air brakes operative. When handling snow plow in switching movements, snow plow must be handled alone, or with not more than one car.

#### Movements on Leads and Yard Tracks

**808 (RO).** Train, engine, and yard movements approaching leads in yards must stop before fouling lead unless it is known that switches are properly lined and lead is clear.

#### Track Scales

**808 (RO-1).** Locomotives must not be moved over live rails of track scales and when moved over dead rails of track scales, a speed of 5 MPH must not be exceeded.

Cars must not be violently stopped by impact, sudden application of brakes or by blocking wheels. After cars are weighed, they must not be moved over live rails if possible to avoid it. When making impact with cars on scales, speed must not exceed 2 MPH and 4 MPH must not be exceeded over scales in any case.

Cars on live rail must not be moved by other cars or engines moving on dead rail, or vice versa. Cars must not be moved over scale with one truck on live rail and other truck on dead rail.

Scale track switches must be lined for dead rails when scales not in use.

#### Long Cars

**808 (RO-2).** Freight cars 85 ft. or more in length must not be handled on curves in excess of 16 degrees except as follows:

Where movement is authorized by an officer, these cars may be handled on curves of more than 16 degrees but not exceeding 20 degrees at speed not exceeding 4 MPH. A member of crew must watch movements closely, prepared to give stop signal if any indication of failure to safely negotiate the curve.

**808 (RO-3).** In handling hydra-cushion cars on industrial tracks where curvature is 30 degrees or greater, movement is restricted to single car and unit.

#### Engine Service

**920 (RO).** Rear view mirror of engines so equipped must not be used for observing conditions or hand signals in making backup or switching movements or in making couplings.

**920 (RO-1).** Engineer must verify accuracy of speedometer not less than twice during each trip, using watch to make time check between mileposts. First check must be made at first opportunity after engineer takes charge of locomotive.

When it is found that speedometer is not accurate, report must be made to train dispatcher at first opportunity, indicating variation.

**920 (RO-2).** When necessary to isolate an engine enroute, or when one or more units in locomotive consists are not functioning properly, train dispatcher must be notified at first opportunity.

**920 (RO-3).** On diesel locomotives, side and end doors of engine rooms must be kept closed while the locomotives are moving.

**920 (RO-4).** Except when shoving cars, an engine consisting of two or more units, with control unit at each end, must be operated from leading control unit in direction of movement unless such movements are protected by a qualified employe.

## ADDITIONAL SPECIAL RULES — FIFTH SUBDIVISION and BRANCHES

#### Railroad Crossings and Junctions

**98 (RO-1).** At Blakeslee Jct. movements are governed by Automatic Interlocking signals. Push button located on signal house may be operated to obtain signal indication.

#### Drawbridges

**98 (RO-2).** At Tacoma, all trains and engines must stop at stop sign and must not proceed onto draw span of bridge unless they have called for, received and acknowledged proceed signal from Bridge-tender.

#### Barge Operations

**101 (RO).** At Seattle rail-barge docks, Harbor Island, clearance is extremely close on all tracks approaching barge apron and on the barges. Employes must not ride on side, end or top of cars being moved on or off barges beyond "Impaired Clearance" signs.

Engine foreman or barge-master must receive permission from barge company supervisor before any movement is made on or off barges. All cars must have air brakes cut in and operative when moving on or off barges and all movements must be made with extreme care.

To avoid improper coupling of cars against bumper couplers at end of barges, no coupling will be made with more cars than the barge track will hold, not including empty reacher cars.

Engines are not permitted on apron of barge slip at Pier 16.

#### Derails

**104 (RO-6).** Main track derail is located at MP 5.8 on Olympia Branch.

#### Centralized Traffic Control System

**269 (RO-2).** Between Black River and Fife the following rules will apply:

**269.** When a train or engine is stopped by a Stop signal and no conflicting movement is evident, a member of the crew must immediately communicate with the control operator and be governed by his instructions. Authority to proceed will be given by form C Clearance which must be copied by a member of the crew, repeated to the control operator and delivered to the engineer.

When authorized to proceed, train or engine may proceed at once at restricted speed to the next signal except that when so instructed by the control operator, train or engine must be moved forward until leading wheels are 100 feet past the Stop signal, wait ten minutes, then proceed at restricted speed to the next signal.

**Exception: — Clearance Form C will not be required when movement is leaving the main track, is leaving CTC territory, or the entire movement is within yard limits.**

**269 (A).** When stopped by a Stop signal and communication with the control operator has failed, train or engine must not proceed except on signal indication or until communication is restored and authority is received from the control operator.

**Exception: A train or engine stopped by a Stop signal at the entering signal at a station and unable to communicate with the control operator may move forward, when preceded by a flagman, to the leaving signal at that station, clearing main track when practicable.**

**269 (B).** Emergency push buttons installed in telephone booths of relay houses at dual control switch locations may be used in an attempt to obtain proceed signal indication only when so instructed by the control operator, or when communication has failed.

When instructed by the control operator to use emergency push button for the desired direction, if indication permitting train to proceed is received on

governing signal, train or engine may proceed in accordance with the signal indication.

When stopped by a Stop signal and communication has failed, proper emergency push button may be used, and if indication permitting train to proceed is then received, train or engine may proceed but must move at restricted speed to the next Stop signal, keeping a close look out for track car or for men and equipment on track without flag protection.

**269 (C).** If a train or engine fails to stop before passing a signal displaying Stop indication, front of train must be protected immediately as prescribed by Rule 99. A member of crew must communicate with control operator at once and be governed by his instructions."

#### Close Clearances

**799 (RO).** Employees are warned that clearances to trolley poles are close at locations shown below:

Station	Location	Railroad
Black River	.....	MILW
Argo Seattle	..... Argo yard lead and between Argo and Seattle passenger station	MILW
Georgetown	..... West end of siding entering main track	MILW

**799 (RO-1).** At Olympia, account insufficient clearance between BN connection scale track and main track, trains or engines must not attempt to pass on main track if trains or engines are moving on connection.

**799 (RO-2).** At Aberdeen, account insufficient clearance between coach track No. 1 just east of passenger station and main track at turnout, trains and engines must not attempt to pass on main track if trains or engines are moving on coach track No. 1.

## SPECIAL RULES — SIXTH SUBDIVISION and BRANCHES and SPOKANE INTERNATIONAL RAILROAD

#### Use of Engine Whistle

**15 (RO).** Within the City limits of Spokane and Pomeroy, and at Walla Walla over crossings at West Cherry Street and Gardeners Assn. west of Mill Creek Bridge, the use of engine whistle is prohibited except to prevent accident not otherwise avoidable.

#### Drawbridge

**98 (RO-3).** At Drawbridge MP 23.45, Wallace Branch, train must stop at stop sign and must not proceed unless authority is received from bridge tender via radio, except that if such authority is not received, a member of crew must determine that draw span is properly closed and locked, and give proceed signal when safe to proceed.

#### Derails

**104 (RO-7).** Main track derails are located at the following points:

Wallace (MP 81.13)	} Spring switch point set in derailing position at all times and must be changed for eastward or descending movement.
Sierra Nevada Spur (300 feet east of refinery track spur)	
Burke (MP 86.3, MP 86.4 and MP 87.0)	

#### Centralized Traffic Control System

**269 (RO-3).** At Wallula, Villard Jct. and Zangar Jct. emergency push buttons installed in telephone booths of relay houses at dual control switch locations may be used in an attempt to obtain proceed signal indication only when so instructed by the control operator, or when communication has failed.

When instructed by the control operator to use emergency push button for the desired direction, if indication permitting train to proceed is received on governing signal, train or engine may proceed in accordance with the signal indication.

When stopped by a Stop signal and communication has failed, proper emergency push button may be used, and if indication permitting train to proceed is then received, train or engine may proceed but must move at restricted speed to the next Stop signal, keeping a close lookout for track car or for men and equipment on track without flag protection.

#### Dual Control Switches

**275 (RO-5).** At Union Pacific controlled interlockings, listed below, when control operator is unable to clear the signal and movement is authorized as prescribed by Rule 609 (a) and 609 (b), levers on control machine must, when possible, be positioned for route to be used.

Selector lever on all switches over which movement is to be made must be placed in HAND position and must not be restored to POWER position until movement over the switch has been completed.

BN Crossing (Spokane) MP 369.2;  
Kalan Drawbridge MP 7.4 Yakima Branch.

#### Controlled Signals

**275 (RO-6).** Train and engine movements between BN Crossing and east end Spokane will be governed by controlled signals located at BN Crossing.

**275 (RO-7).** Stop signals governing movement over dual control switches at east switch Ayer, and at Ayer Jct., and westward Stop signals at west switch Joso, are controlled by control operator at Wallula. A train or engine stopped by these signals must not proceed without authority of train dispatcher at Albina, being governed by his instructions regarding the handling of switches, and movement must be made at restricted speed to next signal. Rules 275 and 275 (A) apply.

**275 (RO-8).** At Cheney, eastward stop signal at MP 350.4 is controlled by Burlington Northern train dispatcher at Spokane. Eastward trains stopped by this signal must immediately communicate with BN train dispatcher and be governed by his instructions.

#### Mechanical Time Lock

**280 (RO-1).** Mechanical time lock has been applied to east switch of house track at Cheney, train or engine must not release this mechanical time lock or move from house track to main track without authority from Union Pacific train dispatcher, Albina.

#### Slide Detector Signals

**509 (RO-1).** On Yakima Branch, between MP 41 and MP 42, slide detector signals, designated by triangular number plates, are in service. When signal displays Stop indication, train must stop before passing and may then proceed at restricted speed to signal at opposite end of protected territory, looking out for damaged rail or obstruction, and report must be made to train dispatcher at first opportunity.

#### Interlocking

**612 (RO).** At Yakima River Bridge, MP 89.4 and BN Crossing MP 91.3, Yakima Branch, trains and engines are governed by automatic interlocking signals and must approach at restricted speed. A train or engine stopped by an interlocking signal must comply with Operating Rule 612. If signal does not change its indication after one minute, flag protection must be provided for movement between home signals governing this trackage.

#### Track Restrictions

**808 (RO-4).** Referring to Special Rule 808 (RO), following tracks have curvature in excess of 30 degrees:

##### Yakima Branch:

Yakima — Wye

##### Pendleton Branch:

Walla Walla — Track 58, Walla Walla Poultry Assn.  
— Track 66, Walla Walla Canning Co.  
— Track 67, Walla Walla Canning Co.

#### Air Brake Rules

**1042 (RO-4).** Before descending grade on Sierra Nevada Branch and Wallace Branch, between Burke and Wallace, all trains and engines handling cars must make the following air test:

Engineer must apply brakes with a 10 lb. brake pipe reduction and trainmen will observe that brakes apply on each car. Angle cock on rear of rear car must be gradually opened to permit solid flow of air to ascertain that brake pipe is not obstructed to engine. Trainmen then must close angle cock and after engineer has released brakes, observe that brake releases on each car. In addition, brake pipe must be fully recharged and retaining valves placed in heavy holding (20 lbs.) position on all loads, and light holding (10 lbs.) position on all empties; engineer must make a 10 lb. brake pipe reduction, release automatic brakes, and wait at least four minutes before starting descending movement.

## APPENDIX 1 RAILROAD CROSSINGS and JUNCTIONS

98 (R). Trains and engines must be governed by the following at the crossings and junctions indicated:

Location	Crossing or Junction	Train Precedence	How Governed
<b>NEBRASKA DIVISION</b>			
<b>Council Bluffs</b>			
13th St. and 4th Ave.	ICG	CNW-ICG	Facing point movements over spring switches are governed by the following aspects and indications displayed by switch point indicator. Green — Switch point fully closed in normal position. (CNW) Yellow — Switch point fully closed in reverse position. (ICG) Red — Stop. Inspect switch point to see fully closed and properly lined before moving over switch.
14th St. & 5th Ave.	BN	UP	Gate
10th Ave. and 14th St.	BN	UP	Stop sign
10th Ave. & 12th St.	CNW	CNW	Stop signs
MP 0.21	BN		BN trains or engines must not enter UP trackage without authority from bridge dispatcher.
<b>Omaha</b>			
Lining Track 6th St.	BN	BN	Gate
20th St.	CRIP & CNW		Interlocking
Summit crossovers between Tracks 1, 2, 3, 4	CNW		Interlocking
N St.			Trains and engines must approach all junction points expecting to find trains entering or leaving main tracks or running tracks. Except where protected by interlocking, trains entering Bridge Subdivision must receive authority from Bridge dispatcher before occupying main track and must be governed by Rule 516 and Special Rule 516 (R).
Q St.	CRIP		ABS. Rules 98, 516, and Special Rule 516 (R).
U St.	CRIP	CRIP	Gate
Gilmore Junction	BN & MoPac		Interlocking. Control Operator Tower B
11th St. between Hall and Burdette	ICG	UP	Gate. 10 MPH maximum speed
5th St. between Harney & Howard Sts.	BN	UP	Automatic interlocking. Operating Rule 612: When a movement approaching crossing enters clearing section, if there is no conflicting movement, signal will display aspect permitting movement to proceed. If movement is delayed after entering approach section, signal may resume Stop indication at expiration of time interval. When it is desired to use crossover between Running Track 8 and Freight House Lead, movement must stop before passing home signal. Both switches of crossover must be lined, which will cause signal to display Stop indication. Push button located on the signal must then be depressed to receive indication permitting movement to proceed. Electrically locked details

Location	Crossing or Junction	Train Precedence	How Governed
are in service on Alcohol Plant spur. Movements entering this spur must occupy short track circuit immediately in advance of derrails in order to release electric lock. For movements from spur, indication light on electric lock will light when padlock is removed from derail if there is no conflicting movement. When indication light is displayed derrails may be operated. Approach clearing section must not be occupied unnecessarily by standing engine or cars.			
<b>First Subdivision and Branches</b>			
Old Main Line-MP 19.2	MoPac		Automatic Interlocking
Fremont-Canning Factory Spur	BN	BN	Gate
Fremont-MP 40.0	BN	UP	Interlocking. When a train or engine is stopped by a signal governing movement over crossing and no conflicting movement is evident, a member of crew must communicate with BN operator and be governed by his instructions. Telephone is located on instrument house near crossing. When governing signal indicates Stop and communication with BN operator has failed, no movement may be made over crossing until flag protection in accordance with Rule 99 has been provided against conflicting movements.
Central City-MP 124.3	BN	UP	Automatic Interlocking. Operating Rule 612.
Central City-MP 124.6	Stromsburg Branch		Westward Stromsburg Branch trains will contact train dispatcher and cross over under block signal protection. If an eastward train is seen approaching, switch must not be opened or crossover occupied until approaching train has stopped.
Grand Island-MP 146.5	BN		Interlocking
<b>Beatrice Branch</b>			
Yutan-MP 5.8	BN		Movements through interlocking are governed as follows: <b>Aspect: RED</b> — Semaphore at right angle to signal mast. <b>Name: Stop. Indication:</b> Stop before any part of train or engine passes signal. <b>Aspect: GREEN</b> — Semaphore at 45° angle to signal mast. <b>Name: Clear. Indication: Proceed.</b>
Badger-MP 113.1	BN		Automatic Interlocking
Wahoo-MP 19.6	BN	UP	Gate. Operating Rules 98, 98 (A) and 98 (B).
Lincoln-MP 56.5	BN		Interlocking
Lincoln-MP 57.4	BN		Interlocking
Lincoln-MP 59.0	BN		Interlocking
<b>Norfolk Branch</b>			
Norfolk-MP 48.7	CNW	CNW	Automatic Interlocking. Emergency push-button release is located in instrument house. Operating Rules 98 (B), 98 (C) and interlocking rules govern.

Location	Crossing or Junction	Train Precedence	How Governed
<b>Stromsburg Branch</b>			
David City-MP 23.5	BN	UP	Stop signs
<b>Ord Branch</b>			
Ord-MP 60.7	BN	UP	Stop signs
<b>Second Subdivision and Branches</b>			
<b>North Platte Branch</b>			
Northport-MP 115.5	BN		Automatic Interlocking
<b>Third Subdivision</b>			
Union MP 81.0	BN		Eastward BN trains must not release mechanical time lock (remove padlock from hasp) without authority from UP Train Dispatcher. Movement to UP trackage is governed by signal indication. Rule 509 governs.
Sterling MP 56.05, 56.71, 57.48	BN		BN Train and engine movements must have UP Train Dispatcher's authority before fouling UP main track.

## WYOMING DIVISION

### First Subdivision and Branches

MP 4	DRGW		Signal Indication
CP 5	BN		CTC signals
Eaton MP 59.3	GW	UP	Semi-automatic interlocking. When stopped by signal governing movement over crossing and no conflicting movement is evident, member of crew must communicate with dispatcher and be governed by his instructions but need not receive Form C Clearance. Operating Rule 613 governs.

### Boulder Branch

Erie-MP 15.1	BN	UP	Stop signs
Valmont Spur-MP 1.0	BN	UP	Gate
C&S Crossing-MP 26.0	BN	BN	Gate
<b>Fort Collins Branch</b>			
Kelim-MP 9.0	GW	GW	Stop signs
Fort Collins-MP 25.2	BN	BN	Activating push button is located in lock box mounted on either signal mast. Before signal will clear: [1]. BN track occupancy indicator must indicate unoccupied (Rule 241 D). [2]. Gate must be properly secured for route to be used. If signal does not clear, Operating Rule 613 governs.

Fort Collins-MP 25.3	BN	BN	Gate
----------------------	----	----	------

## KANSAS DIVISION

### First Subdivision and Branches

Berger Ave. & Railroad St., Kansas City, KS	SSW	UP	Gate
Minn. Ave. & MoPac, Bridge, Kansas City, KS	MoPac		Interlocking
Minn. Ave. & 2nd St., Kansas City, KS	MoPac		Interlocking
State Ave., near Second St., Kansas City, KS	MoPac		Interlocking
KAW Jct.-MP 5.2	SSW	UP	Interlocking
Bonner Springs-MP 18.0		ATSF	When signal governing route to be used displays Stop indication, member of crew must communicate with train dispatcher for instructions. If movement is verbally authorized by train dispatcher, member of crew must precede the movement and if conditions permit and no conflicting movement is evident, he will signal his
Topeka-MP 67.5		ATSF	
Topeka Frt. House lead		SSW	
Topeka-MP 68.2	SSW	UP	

Location	Crossing or Junction	Train Precedence	How Governed
Frankfort-MP 130.9	MoPac		Interlocking and CTC. When stopped by Stop signal and no conflicting movement is evident, member of crew must communicate with dispatcher. When instructed by dispatcher, time release must be operated and if signal does not change at expiration of time release interval, movement may be made in compliance with Operating Rules 269, 275, 612 and 614.
<b>St. Joseph Branch</b>			
St. Joseph	MoPac		Stop signs
St. Joseph	BN	BN	Signal indications. When stopped by signal governing movement, a member of crew must communicate with BN operator and be governed by his instructions.
Hiawatha-MP 42.2	MoPac		Automatic interlocking. Operating Rule 612.
<b>Second Subdivision and Branches</b>			
Endicott-MP 180.23	BN		Interlocking and CTC. When stopped by Stop signal and no conflicting movement is evident, member of crew must contact dispatcher. When instructed by dispatcher, time release must be operated and if signal does not change at expiration of time release interval, movement may be made in compliance with Operating Rules 269, 612 and 614.
Belevidere-MP 210.2	BN		Electric Lock. Electric lock hand operated switches and associated stop signals govern movement in either direction on UP or BN. Electric locks release automatically on BN approach occupancy or remain locked on UP occupancy. Time release of UP locked route is provided. Rules 269, 280 thru 282 (A) and 612 govern.
Edgar-MP 233.7	BN		
Hastings-MP 260.5	BN		Interlocking and CTC. When a train or engine is stopped by interlocking signal and no conflicting movement is evident, movement may be made complying with Operating Rules 269 and 609.
<b>Grand Island Branch</b>			
MP 249.6	BN		Stop signs
<b>Denver Cut-off and Branches</b>			
Abilene-MP 164.5	ATSF		Automatic Interlocking. Operating Rule 612 and 614.
West Abilene-MP 165.0	ATSF		Operating Rule 516 and Special Rule 516 (R).
East Salina-MP 184.6	ATSF		Dwarf signal
Salina-MP 187.2	ATSF	UP	Automatic Interlocking. Operating Rule 612 and 614.
Ellsworth-MP 224.4	BN	UP	Signals and electric locked gate. Operating Rules 613 and 614.
<b>Solomon Branch</b>			
Minneapolis-MP 23.7	ATSF	UP	Stop signs
Beloit-MP 57.2	MoPac	MoPac	Stop signs
Limon-MP 550.5	C&LC	UP	Signal indications. After stopping, crewmember must go to the crossing to give proceed signal when safe to do so.

Location	Crossing or Junction	Train Precedence	How Governed
<b>McPherson Branch</b>			
Salina-MP 0.5	ATSF	UP	Stop signs
Salina-MP 0.6	MoPac		Stop signs
Lindsborg-MP 20.7	MoPac	MoPac	Gate. Stop at switch target until gate has been set against MoPac. When entire train has passed the target on opposite side of crossing, the gate must be set against UP.
McPherson-MP 35.1	ATSF	ATSF	Stop signs
<b>Plainville Branch</b>			
Lincoln Center-MP 33.8	ATSF	UP	Gate. Stop signs
<b>UTAH DIVISION</b>			
<b>Salt Lake City Terminal Area</b>			
North Salt Lake (MP 787.7)	DRGW	DRGW	Electric locked switches and derails. At North Salt Lake and Becks, before moving over DRGW main track, DRGW dispatcher Salt Lake must be contacted for release of electric locks. Both DRGW switches may then be hand operated and movement may proceed on signal indication.  At North Salt Lake, normal position of switch Cudahy spur to Beeline spur is for Beeline spur. This switch has a mechanical lock and will release when switch from DRGW main track to Cudahy spur is reversed.  Switch to Beeline spur must be restored to normal position before DRGW main track switch is restored to normal. Lunar signal indication authorizes movement Cudahy spur to Beeline spur. Yellow signal indication authorizes movement Cudahy spur to DRGW main track. When communication fails, or dispatcher is unable to release electric locks, instructions posted in telephone booth and Operating Rule 613 will govern.
Becks (MP 786.1)	DRGW	DRGW	
Salt Lake City (First South and Eleventh West Streets)	WP		CTC Signals
Salt Lake City (Between So. Temple and First South St. on Fifth West St.)	DRGW		Manual Interlocking
Salt Lake City (MP 782.6, MP 782.4, Second Subdiv.)	DRGW		Automatic Interlocking. After a movement over crossing has cleared interlocking limits, if necessary to make a reverse movement over crossing, push button in box on home signal must be depressed for five seconds then released to obtain signal indication for movement over crossing.
Salt Lake City (Between Eighth and Ninth South Streets on Fifth West St., Utah Junk Spur)	DRGW	DRGW	DRGW trains do not stop. UP crew members stop and line derail. Operating Rule 98 (A).
Salt Lake City (MP P-797.9, Provo Subdivision)	DRGW	UP	Semi-automatic Interlocking. Operating Rule 613.
Near Burton (MP P-796.6, Provo Subdivision)	DRGW	UP	Gate. Operating Rule 613.
Salt Lake City (Fourth West Street and Van Buren Ave.)	DRGW (2 tracks)	DRGW	Gates. After stopping for stop sign if no conflicting movement, both gates must be secured against DRGW movements. After moving over crossing, gates must be restored to normal position.
Midvale	DRGW		Stop signs. Operating Rule 98 (A).

Location	Crossing or Junction	Train Precedence	How Governed
<b>Ogden Terminal Area</b>			
21st Street	DRGW freight main track crosses yard	DRGW	When stopped by signal governing movement over this crossing and no conflicting movement evident, a member of crew must be sent to crossing and if derails on DRGW are in derailing position, movement may proceed on hand signal from employe at the crossing.
<b>Evona Branch connection with DRGW to joint sugar works</b>			Dual control switches are in service. Signals and switches controlled by DRGW dispatcher. Authority must be received from DRGW dispatcher for movement.
Cecil Jct.	UP-SP		Block signals and switchtender.  At Cecil Junction, all movements are controlled by switchtender. Trains or engines must call for signal (Rule 14-j) and must receive proceed signal from switchtender before proceeding.  At Cecil Junction, train or engine on westward main track may pass signal 7813 without stopping, provided proceed signal is received from switchtender, but movement must be made at restricted speed.
<b>First Subdivision and Branches</b>			
Syracuse Branch (MP 0.3)	DRGW	DRGW	Manual interlocking controlled by DRGW dispatcher.
<b>Second Subdivision</b>			
Near Geneva (MP P-757.3) (Provo Subdiv.)	DRGW		Automatic interlocking with movable point frogs, release section is located 500 ft. east of westward interlocking home signal. Westward trains occupying approach section of interlocking in advance of release section sign for five minutes or more will automatically release interlocking and signals will change to stop indication. To again clear signal, westward trains will proceed into release section and signal should change to proceed indication after two minutes. If signal does not change in two minutes, Operating Rule 612 and instructions in signal case govern, including hand operation of movable point frogs. Westward UP trains or engines standing between switches at Geneva will cause signals to display stop indication for DRGW trains and opposing UP trains. To clear signals, west switch of Geneva siding must be lined for siding. Member of crew of single unit engine without cars, rail detector car or operator of track car must place selector levers on movable point frogs in HAND position before using crossing.
Garfield (MP 767.1)	KCC Conn.	UP	Electric Lock
<b>CALIFORNIA DIVISION</b>			
<b>Second Subdivision and Branches</b>			
Ontario (MP 38.1)	SP		When an eastward train or engine is stopped by semi-automatic interlocking signal, Operating Rule 613 will govern.  When a westward train or engine is stopped at CTC signal located 1550 ft. east of crossing, in addition to receiving clearance Form C, Operating Rule 613 will govern.

Location	Crossing or Junction	Train Precedence	How Governed
MP 33.0	SP		CTC Signals
Puente Jct. (MP 17.8)	SP		CTC Signals
Bartolo (MP 11.2)	SP		CTC Signals
Mission Tower	ATSF		Interlocking. Rule 609.
Redondo Jct.	ATSF		Interlocking. Rule 609.
Violet Alley, Los Angeles (100 ft. east of Santa Fe Ave.)	ATSF	UP	Member of crew must protect crossing UP old main track.
Violet Alley, Los Angeles (North leg of wye)	ATSF	ATSF	Member of crew must protect crossing Santa Fe lead track.
Santa Fe Ave., Los Angeles	ATSF	ATSF	UP trains and engines stop. Member of crew protect two crossings.
15th St., Los Angeles	ATSF		Stop signs.
<b>San Pedro Branch</b>			
Hobart (MP 3.1)	ATSF	ATSF	Interlocking. Rule 609.
MP 3.6 MP 4.6-C MP 4.8-C	LA Jct. Ry.	UP	Semi-Automatic Interlocking. LA Jct. Ry. engines stop and member of crew protect crossings.
South Industry Joint UP-SP Lead	Bethlehem Steel	UP-SP	Stop sign. UP-SP engines stop and if crossing is clear and derails on Bethlehem track are in place, movement may be made over crossing. Bethlehem engines stop and member of crew protect crossing.
Between Bethlehem Steel and Lipsett	Bethlehem Steel	UP	Stop signs. Member of crew protect crossing.
MP 5.1	SP		Automatic Interlocking. Rule 612.
MP 7.4	SP		Automatic Interlocking. Rule 612.
MP 11.2	SP		Automatic Interlocking. Rule 612.
MP 17.4	SP		Automatic Interlocking. Rule 612.
MP 21.7	SP		Stop signs. Rule 98 (A). When fog or inclement weather conditions exist, impairing vision, a lighted red fusee must be placed not less than 100 ft. each side of crossing before movement is made over crossing. Southern Pacific and Santa Fe trains and engines have precedence over Union Pacific trains and engines when using this crossing and will proceed at 10 MPH without stopping.
Henry Ford Boulevard (MP 23.2)	Drawbridge		Interlocking. Rule 609.
Permanente Co. Spur	UP		Stop sign. Member of crew protect crossing.
<b>Anaheim Branch</b>			
MP 0.1	SP		CTC Signals
MP 15.5	ATSF	ATSF	Interlocking. See instructions in phone box near derails.
Anaheim Sugar Spur (MP 19.0)	ATSF	UP	ATSF trains and engines stop and member of crew protect crossing. UP trains and engines approach prepared to stop unless crossing is clear.
<b>OREGON DIVISION</b>			
<b>Albina Terminal</b>			
East Portland (S.E. Second Ave.)	BN	UP	Stop signs
<b>Fifth Subdivision and Branches</b>			
South Aberdeen	BN	BN	Stop signs

Location	Crossing or Junction	Train Precedence	How Governed
Olympia (Jefferson and 7th St.)	BN	UP	Stop signs
Tacoma (Muni Line)	BN	BN	Stop signs
Tacoma, Tidewater	BN	BN	Stop Signs
Seattle (Duwamish Ave. and East Marginal Way).	BN MILW	BN MILW	Stop signs
Seattle (East Marginal Way & Spokane St.)	BN	BN	Stop signs
Seattle (Railroad Ave. and Atlantic St.)	BN MILW	BN MILW	Stop signs
<b>Sixth Subdivision and Branches</b>			
Spokane (BN Crossing MP 369.2)	BN		Interlocking
Spokane (BN Crossing old yard lead.)	BN		Automatic Interlocking. Movements are governed by automatic interlocking signals. Push buttons, located on signals, may be operated to obtain signal indication for a reverse movement. Emergency release push button is located near crossing. Instructions are posted in box.
Garfield (MP 95.4)	BN	UP	Stop signs
Oakesdale (MP 39.7)	BN	UP	Stop signs
Walla Walla (MP 47.2)	BN	UP	Stop signs
Walla Walla (MP 44.2)	WWV	UP	Gate
Milton-Freewater (MP 36.3)	WWV	UP	Gate
Parker (MP 91.3)	BN		Automatic Interlocking
Yakima River Bridge (MP 89.4) BN Crossing (MP 91.3)	BN	UP	Automatic Interlocking At Yakima River Bridge, MP 89.4 and BN Crossing MP 91.3. Yakima Branch, trains and engines are governed by automatic interlocking signals and must approach at restricted speed. A train or engine stopped by an interlocking signal must comply with Operating Rule 612. If signal does not change its indication after one minute, flag protection must be provided for movement between home signals governing this trackage.
Garrett (MP 28.7)	WWV	UP	Gate
Dayton (MP 13.0)	BN	BN	Stop signs
Pullman (MP 19.3)	BN	UP	Stop signs
Wallace (MP 80.4)	BN	UP	Stop signs
<b>Spokane Subdivision (S.I.R.R.)</b>			
Spokane (MP 0.04)	BN	BN	Stop signs
Grand Junction (MP 22.1)	BN	SI	Gates
Sandpoint (MP 75.3)	BN		Interlocking (Controlled by BN Dispatcher).
Bonnors Ferry (MP 109.3)	BN	SI	Gates
<b>Coeur d'Alene Branch</b>			
Gibbs (MP 7.8)	BN	BN MILW	Stop signs
Coeur d'Alene (MP 8.7)	BN	BN	Stop signs

## APPENDIX 2 PUBLIC CROSSINGS

103 (R). At locations listed below, crossing movements are governed as follows:

Location	How Governed
<b>Nebraska Division</b>	
South Omaha	Automatic crossing signals and gates are in service at Washington Street, and automatic crossing signals at Madison Street. Cars must not be left standing on bonded portion of these tracks which extends 50 ft. on each side of these crossings. Before moving over these crossings, switching movements in either direction on Long Track, Hold Track, or industry track which parallels eastward main track, must stop not less than 50 ft. from crossing and in proceeding must keep careful lookout for highway traffic.
Gilmore	All movements must stop and crew member sent ahead to act as crossing watchman at 25th Street Crossing on Old Main Line.
Valley	Cars must not be left within 60 ft. of the Spruce Street Crossing MP 28.05. At stockyards crossing, eastward trains stopping to cut off engine must stop before passing white marker post 350 ft. west of crossing to permit crossing gates to clear for highway traffic. After stopping, movements toward crossing must not exceed 5 MPH.
Waterloo	All movements on industry track, MP 25.6 must stop before crossing Highway 275 and know that automatic crossing signals are in operation before proceeding. Stop must be made on circuit, marked by insulated joints, painted aluminum, 50 ft. each side of the crossing.
Central City	While standing, freight trains must keep all crossings clear
Grand Island	Movements on industrial track must stop before crossing U.S. Highway 30 and know that automatic crossing signals are in operation before proceeding. Stop must be made on circuit, marked by insulated joints painted aluminum, extending 50 ft. on each side of crossing. On BN, if length of train permits, Stuhr Rd. must be left clear.
Kearney	When Signal 1890 displays Stop and Proceed indication, eastward trains on main track must stop clear of Fifth Avenue crossing.
Pine Bluffs	While standing, freight trains must keep crossing clear at MP 466.5.
Hillsdale	While standing, freight trains must keep crossing at MP 489.95 clear between the hours of 8:30 a.m. and 10:00 a.m.
<b>Wyoming Division</b>	
Brighton	All movements must stop, and crew member sent ahead to act as crossing watchman at Sugar Factory crossing, Main St.
Fort Collins Branch	At U.S. Highway 34 crossing MP 10.0 movements over highway are governed by eastward and westward two position color light signals which are automatically activated when train is within 1,550 ft. of crossing. When signal displays proceed indication, trains may proceed over U.S. Highway 34 at normal speed. When signal displays Stop indication, trains must stop and be preceded by a flagman over crossing.
Fort Collins	Movements over College Avenue and Cherry Street are governed by signal indication. Activating push button is located in lock box mounted on either signal mast. Before signal will clear: [1]. BN track occupancy indicator must indicate unoccupied (Rule 241 D). [2]. Gate must be properly secured for route to be used. If signal does not clear, Operating Rule 613 governs.
CP 5	While standing, eastward trains on Dent Branch must remain west of Brighton paved road.

Location	How Governed
Greeley	When moving over public or private crossing on any track other than main track, a speed of 5 MPH must not be exceeded. A member of crew must precede movement and act as crossing watchman as follows: 13th Street Crossing — Movements to or from Sixth Avenue or Rogers Spur; 8th Street Crossing — Movements to or from West House or House track. Cars must not be left closer than 200 ft. on either side of 16th Street crossing on South Pass. Trains or engines must not exceed 5 MPH on Great Western Sugar factor spur on 16th Street. Movements over U.S. Bypass are governed by signal indication. A member of crew must operate push button to change signal from red to green. Push button for eastward movement is located on signal mast on south side of track. Push button for westward movement is located on signal mast on north side of track.
Boulder	Movements over 30th Street are governed by signal indication. A member of crew must operate push button to change signal from red to green. Push button for westward movements located on instrument case north of track; for eastward movements on wooden post south of track. Crossing signals at 28th St. are governed by signal indication controlled by push buttons located on instrument case north of track and on wood post south of track.
CP 511	After stopping, eastward trains must whistle to activate crossing protection before proceeding.
Rawlins	The following crossing signal change has been made on the wye track crossing on Cedar Street, Rawlins, Wyoming. Train crew must activate crossing signals prior to obstructing crossing by using their switch key in the new crossing signal control boxes located on north and south sides of Cedar Street. Crossing signals should be deactivated in the same manner after the crossing is cleared.
Wamsutter Bitter Creek Point of Rocks	Between 8:00 a.m. and 5:00 p.m., crossing must not be blocked longer than 10 minutes. Between 5:00 p.m. and 12:01 a.m., crossing must not be blocked more than 30 minutes.
Rock Springs	On South Pass Branch, a member of crew must act as crossing watchman for movement of trains or engines over Bridger Avenue and Grant Street. Trains of 1200 feet or more must not occupy Bridger or Grant St. crossings between 7:00 a.m. and 9:00 a.m.; 11:30 a.m. and 1:30 p.m.; or 4:00 p.m. and 6:00 p.m.
MP 979.28	Mountain Green crossing must not be blocked longer than 10 minutes.
<b>Kansas Division</b>	
Kansas City, Ks.	Crossing signals in Fairfax Industrial District are operated by push buttons located in signal box at edge of street. Signals must be operated a sufficient time to stop traffic before movement begins and until movement has cleared crossing. Signals must not be operated unnecessarily or left in operation after movement is completed. Movement on Industrial Track, MP 16.6, must stop before crossing KS Highway 32 and know that automatic crossing signals are in operation before proceeding. Stop must be made on circuit marked by orange insulated joints extending 50 feet on each side of crossing. Industrial Track 9, Zone 9, stop must be made before crossing Stanley Rd. and know that automatic crossing signals are in operation before proceeding. Stop must be made on circuit marked by orange insulated joints extending 50 ft. on each side of crossing.
Sunflower, Ks.	On Track 22 (west running track), Zone 10, stop must be made before crossing Sunshine Road and know that automatic crossing signals are in operation before proceeding. Stop must be made on circuit marked by painted insulated joints extending 65' south of crossing.

**Location**

**How Governed**

On Spur 3 Track, Zone 14, stop must be made before crossing Fairfax Trafficway and know that automatic crossing signals are in operation before proceeding. Stop must be made on circuit marked by painted insulated joints extending 125' west of crossing.

On Phillips Tail Lead Track, Zone 16, stop must be made before crossing Fairfax Trafficway and know that automatic crossing signals are in operation before proceeding. Stop must be made on circuit marked by painted insulated joints extending 85' on each side of crossing.

Marysville

Highway 77 crossing must not be blocked.

St. Joseph Branch

At Morrill, Kansas, the following will govern movements over tracks as shown:

Movement on North and South Elevator Tracks at Morrill, Kansas, MP 53.9, St. Joseph Branch, must stop before crossing Fanning Street and know that automatic crossing signals are in operation before proceeding. Stop must be made on circuit marked by orange painted insulated joints extending 25' on each side of crossing.

Movement on North Elevator Track at Morrill, Kansas, MP 53.9, St. Joseph Branch, must stop before crossing Roxana Street in eastward direction only and know that automatic crossing signals are in operation before proceeding. Stop must be made on circuit marked by orange painted insulated joints extending 100' west of crossing.

**Utah Division**

Salt Lake City

On running track between Seventh North and Fourteenth North, speed of 10 MPH must not be exceeded over road crossing into rip track area, keeping careful lookout for vehicular traffic.

On Fourth West extension, yard movements must stop at Fourteenth South and Eighteenth South Streets and a member of crew must protect movement over the crossing.

Becks

When using lead to auto unloading facility a member of crew must protect vehicular traffic when crossing Frontage Road.

Crews must provide crossing protection for switching movements over public crossing at 100 South Street.

Grant Tower

When signal governing movement through Grant Tower interlocking is at Stop, eastward Second Subdivision trains must stop clear of Ninth West Street until authorized to proceed.

Ogden

12th Street crossing is not to be blocked by train or engine standing on crossing for more than five (5) minutes.

If occasion arises when trouble causes delay to train or yard cut blocking 12th Street in excess of five (5) minutes, crossing must be cut.

These instructions conform to City Ordinance and employes failing to comply with them will also be in violation of the City Ordinance and subject to fine.

Ogden

At SP Jct., when an eastward train is held out of Ogden yard, 12th Street crossing must be cut on arrival and train must not be re-coupled until switchtender at Cecil Jct. advises train may enter yard and signal indication permits train to proceed to Cecil Jct.

All trains and engines must stop and be preceded by flagman over the following public crossings and flagmen must display lighted fusee at night.

Garland Sugar Factor —  
Three tracks crossing  
highway.

Bunker —  
Main highway crossing  
on spur track.

Lehi —  
Main highway crossing  
on Sugar Factory spur.

Pleasant Grove —  
Main Street crossing on  
United Concrete Co.  
Spur.

Nellis Air Base spur —  
Highway 91.

Lovell Spur — Highway  
91.

Hardy —  
Main highway crossing  
on beet spur

Arrolime Spur —  
Highway 91.

**Location**

**How Governed**

Hardy —  
Main highway crossing  
on Western Ware-  
house Spur.

Geneva

Geneva Steel Company plant, where spur into plant crosses highway, when cars are being shoved over this crossing, crossing must be protected by a member of crew.

Apex

On Fiberboard Spur, highway crossing between Free-way Bridge and Apex must not be blocked by standing cars.

Caliente

When public crossing is cut, crossing must be cleared not less than 150 ft. on each side of crossing.

Clearfield

City ordinance requires that 2nd South Main Street and 700 South must not be blocked longer than 15 minutes.

**California Division**

Within the State of California, trains or engines must comply with the provisions of General Order No. 135 of the Public Utilities Commission which reads:

- 1. Train Movements** — Except as provided in Paragraph 5, a public grade crossing which is blocked by a stopped train, other than a passenger train, must be opened within 10 minutes, unless no vehicle or pedestrian is waiting at the crossing. Such a cleared crossing must be left open until it is known that the train is ready to depart. When recoupling such a train at the crossing, movement must be made promptly, consistent with safety.
- 2. Switching Movements** — Switching over public grade crossings should be avoided whenever reasonably possible. If not reasonably possible, such crossings must be cleared frequently to allow a vehicle or pedestrian to pass and must not be occupied continuously for longer than 10 minutes unless no vehicle or pedestrian is waiting at the crossings.
- 3. Grade Crossing Protection Circuits** — Cars or locomotives must not be left standing nor switches left open within the controlling circuits of automatic gate protection devices unless time-out features are provided to allow the gate arms to rise.
- There are no time restrictions for crossing occupancy for a moving train continuing in the same direction.
- These time limit provisions shall not apply to any blocking resulting from compliance with State and Federal laws and regulations, terrain and physical conditions, adverse weather conditions, conditions rendering the roadbed or track structure unsafe, mechanical failures, train accidents, or other occurrences over which the railroad has no control, except that such crossing shall be cleared with reasonable dispatch.
- In the event of any uncontrolled blockage involving more than one grade crossing and a peace officer is on the scene, primary consideration shall be given to the clearing of that crossing which, in the peace officer's judgment, will result in the minimum delay to vehicular traffic.
- A crew member of a train blocking a public crossing shall immediately take all reasonable steps, consistent with the safe operation of such train, to clear the crossing upon receiving information from a peace officer, member of any fire department, as defined in Section 2801 of the Vehicle Code, that emergency circumstances require the clearing of the crossing.

Manuel Lead  
Sepulveda Blvd.

All trains and engines must stop and be preceded by a flagman over crossing.

Manuel

Train crossing Sepulveda Blvd. on Manuel lead must stop clear of Sepulveda Blvd. to open gates at the Manuel holding yard. Gates must be closed and locked after movement is completed.

Los Angeles

Referring to Rule 103 (E). Stop signs have been installed at various locations on industry and spur tracks in the Los Angeles area, near street crossings where automatic crossing signals have been installed.

Trains or engines must stop before passing sign and it must be known that crossing protection is activated before entering street area.

The city of Los Angeles has placed the following restrictions on train and engine movements over Olympic Blvd. and Lemon St. in vicinity of Alameda Freight Terminal:

- (1) 7:00 a.m. and 8:00 a.m., one locomotive in each direction and one drag one way of not in excess of 10 cars.
- (2) 8:01 a.m. to 9:30 a.m., one locomotive in each direction and one drag one way of not in excess of 15 cars.
- (3) 3:30 p.m. to 4:44 p.m., also 5:46 p.m. to 6:00 p.m., a total of one locomotive in each direction and one drag in each direction of not in excess of 15 cars each.
- (4) 4:45 p.m. to 5:45 p.m. (Not to use crossing at all.)
- (5) 6:30 a.m. to 6:30 p.m., no movements may block the crossing for a total period of time in excess of 6 minutes out of any 15 minute interval.

Location	How Governed
	Yardmasters as well as crews must see that these restrictions are complied with.
North Main Street, Los Angeles	Between Pasadena Jct. and Dayton Ave. tower, marker posts indicate the limits of timeout crossing signal circuits. When stop is to be made approaching Main Street, train or engine must stop before passing marker posts. If necessary to stop after crossing Main Street, stop must be made beyond marker posts in order to release automatic gates. After stop has been made, any further movement toward the crossing must be made in compliance with Rule 103 (E).
Drott	When shoving cars into No. 1, 2, 3 or 4 Drott tracks, all movements must stop before passing west side of freeway bridge and a member of crew must protect movement over road crossing leading to Trailer Dock Office.
Bandini Blvd.	All trains or engines must stop at stop sign at Bandini Blvd. crossing. Before moving over crossing it must be known that gates are down.
Glendale Branch	After stopping, all trains and engines must approach and pass over San Fernando Road and Fletcher Drive very carefully, keeping sharp lookout for street traffic.
Anaheim Branch	All trains and engines must be prepared to stop at Harbor Blvd. near Fullerton, MP 17.3. Stop signs have been installed each side of Broadway Street crossing, Anaheim. Trains or engines must stop before passing stop sign. During daylight hours, trainman must precede train or engine over crossing. During nighttime hours, trainman must place a lighted fusee on each side of track and precede train or engine over crossing with lighted lantern.
City of Industry	Automatic crossing gates are in service, Turnbull Canyon Road, MP 17.2. If necessary for train stopped in siding to cut crossing, cut will be made clearing aluminum stripes on rails each side of crossing. Any cars left standing on either side of crossing must also be left clear of aluminum stripes. Crew members can raise gates by operating switch key control box located on instrument house west of crossing. Key need not remain in release box to affect crossing gate clearance. Black switch key control box keyed for Union Pacific and Southern Pacific switch keys.
Riverside	Seventh Street crossing, MP 57.57, provided with key release for clearing crossing gates with train or cut of cars on immediate approach of siding east side of crossing only. Key need not be left in release box.
Streeter	Streeter Avenue crossing, MP 53.2, is provided with key release for both Main Track and Siding. With train or cut of cars on either east or west immediate approach, or both, crossing gate clearance can be effected by use of key release located on instrument house west of crossing marked "Siding" and "Main Track". Key need not remain in release box to effect crossing gate clearance on Main Track.
Nipton MP 227.5	With train or cut of cars on either east or west immediate approach, or both crossing gate clearance can be effected by use of key release located on instrument house west of crossing, marked "Siding." Key need not remain in release box.
<b>Idaho Division</b>	
Ketchum Branch	At MP 68.24, trains and engines must stop clear of Baldy Mountain Ski Lift crossing before proceeding.
Emmett	Running switches or permitting cars to run free over Washington Street crossing is prohibited.
Soda Springs	On Monsanto Chemical Plant Track No. 4, near Furnace Bldg., hand activated crossing signals have been installed. Train movements will receive a red signal until push button located on signal mast is activated. After truck traffic is stopped, signal will display lunar to proceed across crossing.

Location	How Governed
<b>Oregon Division</b>	
Baker	On Ellingson Spur and West leg of wye, movements over Broadway Street must be protected by flagman. On Industry Spur movement over Campbell Street must be protected by flagman. Street crossings at Campbell and Auburn Streets must not be blocked in excess of five minutes.
Barnhart	When movements to or from ballast pit are made over public crossing, a member of the crew must be stationed on each side of track at the crossing to stop highway traffic.
The Dalles	Public crossings must not be blocked longer than 10 minutes.
Troutdale	Public crossings must not be blocked longer than 5 minutes.
Portland	Northern Pacific Lumber Co. trackage crossing signals are controlled by control boxes located on signal masts on each side of Whitaker Way. Signals must be activated by crew member by use of switch key. Movement must not be made over crossing until 20 seconds after crossing protection activated. Member of crew must deactivate crossing protection after movement completed.  The following will govern trains and engines at the public crossings named:  Trains, engines or cars must not be stopped on street crossings longer than five minutes. Switching movements over specific streets, posted at Spokane govern movements.
Spokane, within city limits	
Sandpoint	Member of crew must be on ground and stop vehicular traffic before switch movements are made on all street crossings.

## APPENDIX 3 DUAL CONTROL CROSSOVERS AND TURNOUTS

104 (R). ACS may be inoperative through turnouts and crossovers. Movements through turnouts and crossovers are governed by block signal indication and the speed specified in timetable for each type of turnout.

**Exception:** At speed signal locations, signal indication will specify speed through turnouts and crossovers.

**No. 20 Turnouts are as follows:**

### NEBRASKA DIVISION

Location	MP	Between Tracks
Gibbon	174.96	1 & 2
	175.11	1 & 2
	175.18	1 & 2
	175.22	2 & Kansas Division Main Track 2
	175.28	1 & 2
Buda	183.75	1 & 2
	183.85	1 & 2
Farr	255.6	1 & Siding
CP274	274.0	1 & 2, 2 & 3
CP276	276.0	1 & 2, 2 & 3
CP283	283.38	Westward Main Track & West Belt Track
	283.4	1 & 2
	284.37	Westward Main Track
North Platte	285.0	EB Departure Yard & Eastward Main Track
	285.5	EB Departure Yard & Eastward Main Track
	289.68	Westward Main Track
CP291	291.0	1 & 2, 1 & Departure lead and Departure lead & coal departure track.
CP298	297.96	1 & Siding
	298.0	South Running Track No. 1 & No. 2 track
O'Fallons	300.27	1 & Siding
	300.5	1 & 2
	300.15	1 & 2 & 1 to North Platte Branch
CP312	311.6	1 & 2
	311.16	1 & 2
CP322	322.4	1 & 2
	322.14	1 & 2
	332.3	1 & Siding
Ogallala	334.5	1 & Siding
	334.6	1 & 2
	334.8	1 & 2
CP350	349.6	1 & 2
	349.8	1 & 2
CP363	363.0	1 & 2
	363.10	2 & Siding, 1 & Siding
Julesburg	364.75	2 & Siding
	365.0	1 & 2
	365.10	2nd & 3rd Subdivision
CP378	377.5	1 & 2
CP392	392.0	1 & 2
Sidney	407.8	1 & 2
CP424	423.9	1 & 2
CP437	437.10	1 & 2
	437.20	1 & 2
CP449	448.44	1 & 2
	448.55	1 & 2
CP459	459.31	1 & 2
	459.42	1 & 2
CP469	469.42	1 & 2
	469.52	1 & 2
CP481	480.69	1 & 2
	480.79	1 & 2
CP491	490.95	1 & 2
	491.05	1 & 2
Archer	501.30	1 & 2
	501.42	1 & 2
Barnett	506.41	1 & 2
	506.49	2 & 3
CP508	508.28	1 & 2
	508.41	1 & 2
	508.44	2 & 3
	508.53	3 & 4

### WYOMING DIVISION

CP45	45.3	DP Main Track and Neb. Div. Main Track
CP518	98.0	West leg of wye to No. 4 track
CP511	510.70	1 & 2
	510.83	2 & 3
	510.87	1 & 2
Dale Junction CP 546	ALL	1 & 2 = MP 554.9 3.
	MP 545.6	

### WYOMING DIVISION Cont.

Location	MP	Between Tracks
CP565	565.25	2 & 3
	565.33	1 & 2
	565.44	1 & 2
CP570	570.5	1 & 2 & Siding
CP582	582.18	1 & 2
	582.25	1 & 2
Lookout	594.10	1 & 2
	594.18	1 & 2
CP601	601.0	1 & 2
Wilcox	608.94	1 & 2
	609.03	1 & 2
CP617	616.8	1 & 2
CP624	624.40	1 & 2
	624.48	1 & 2
CP633	632.6	1 & 2
	638.9	4 & 2
Ramsey	639.01	1 & 2
	639.08	1 & 2
Hanna	643.0	1 & 2, Main Track to North or South Siding
Durrant	650.08	1 & 2
	650.16	1 & 2
Walcott	662.11	1 & 2
	662.39	1 & 2
Benton	672.00	1 & 2
	672.18	1 & 2
CP680	680.20	1 & 2
	680.39	1 & 2
	680.40	1 & Siding
CP681	681.20	2 & Siding
Rawlins	682.78	1 & Siding
CP685	684.86	1 & 2
	685.04	2 & Siding
	685.19	1 & 2
CP700	699.55	1 & Siding
	699.61	1 & 2
CP702	702.09	1 & 2
	702.15	1 & Siding
CP766	766.0	1 & 2
CP801	800.73	1 & 2
	800.80	1 & 2
	800.84	1 & Siding
CP804	803.87	1 & 2
	804.00	1 & Siding
	804.08	1 & 2
CP814	814.64	1 & 2
Peru	824.75	1 & 2
	824.84	1 & 2
CP833	833.35	1 & 2
	833.44	1 & 2
CP844	843.91	1 & 2
	843.97	1 & North Siding
Center Granger	846.65	1 & North Siding
	846.76	1 & Ida. Div. Main Track
	846.84	Ida. Div. Main Track & Siding
	846.95	1 & Ida. Div. Main Track
	847.07	1 & 2
Aspen (CP900)	900.17	1 & 2
	900.26	1 & 2
Altamont (CP904)	904.65	1 & 2
	904.72	1 & 2
Strawberry (CP977)	977.59	1 & 2
	977.71	1 & 2
East Riverdale (CP988)	988.49	1 & 2
	988.58	1 & 2
	988.64	2 & Running Track

### KANSAS DIVISION

West Kansas City	6.5	1 & 2
West Topeka	70.2	1 & 2
East Menoken	73.0	1 & 2, 2 and Denver Cut-Off
Aikins	104.4	1 & Siding
Upland	142.6	Single track & two main tracks
Orrick	155.5	Single track & two main tracks
South Gibbon CP 285	285.2	Single track & two main tracks
Gibbon Jct. (CP175)	287.9	1 & 2 to Nebraska Division

### UTAH DIVISION

Centerville	793.2	1 & 2
CP807	807.2	1 & 2
CP811	811.5	1 & 2
Bridge Junction	817.8	1 & 2

**CALIFORNIA DIVISION**

<b>Location</b>	<b>MP</b>	<b>Between Tracks</b>
Toomey .....	168.6	

**IDAHO DIVISION**

Granger .....	1.6	See Wyoming Division turnouts on previous page
Dingle .....	107.9	end of two main tracks
Pescadero .....	120.4	end of two main tracks
Topaz .....	186.0	end of two main tracks
East Blaser .....	177.0	end of two main tracks
East McCammon .....	189.7	end of two main tracks
Michaud .....	244.4	end of two main tracks
Dietrich .....	314.7	end of two main tracks
Ticeska .....	356.0	end of two main tracks
Reverse .....	393.3	end of two main tracks
Fox .....	448.8	end of two main tracks
Caldwell .....	464.78	end of two main tracks

**OREGON DIVISION**

Lone Tree .....	295.3	end of two main tracks
CP189 .....	188.7	main track and yard
CP184 .....	183.7	departure yard and running track
CP182 .....	182.2	end of running track
Crates .....	81.7	end of double track
Jct. switch Troutdale ....	15.6	

**No. 20 Equilaterals are located as follows:**

MP 565.25 — Between Tracks 2 & 3  
End of two main tracks Shoshone  
End of double track Biggs ... 103.8

**EXCEPT WHERE OTHERWISE SPECIFIED, NO. 14 TURNOUTS ARE INSTALLED AT ALL DUAL CONTROL SWITCHES IN CTC TERRITORY.**

Hand operated switches equipped with No. 14 turnouts are indicated by a figure "14" on switch target.

**No. 10 Turnouts are located as follows:****WYOMING DIVISION**

Borie .....	1 & North siding
CP547, MP 547.3 .....	2 to 1 or 3 *Note
Green River .....	2 & Yard Lead
Riverdale .....	1 & 2
Riverdale .....	2 & East Drill Lead

\*Note — No. 10 Equilateral 30 MPH

**KANSAS DIVISION**

Topeka .....	ATSF crossing
Marysville .....	Yard Lead
Endicott .....	BN Crossing

**NORTH PLATTE YARD**

MP 288.4 .....	Balloon Tracks
----------------	----------------

**UTAH DIVISION**

East Bridge Jct. MP 817.2 .....	1 & 2
Riverdale .....	1 & 2
Riverdale .....	2 & East Drill Lead

**CALIFORNIA DIVISION**

Riverside .....	East and west switches to siding.
Whittier Jct. ....	Anaheim Branch switch.
East Yard .....	Crossover and switch from No. 2 main track to yard lead. Switch, west end of "A" Yard, from No. 2 main track to yard lead.
Downey Road .....	Crossover from No. 2 main track to No. 3 auxiliary track. From No.3 auxiliary track to Hobart lead.
9th St. Jct. ....	No. 1 main track diverging switch to Butte Street Yard.
7th St. Yard .....	No. 1 main track — Dual control switches, east and west end of yard at Olympic Blvd. and 1st Street.

**IDAHO DIVISION**

Kemmerer .....	Switch leading to Cumberland Branch
Pocatello Jct. ....	Montana main track, and crossover between tracks 1 & 2, Junction switch to Montana main track, switch leading to old Kraft lead
Nampa .....	Main track switches at MP 456.50 Boise Jct. to and including crossover at MP 457.14

**OREGON DIVISION**

Rieth .....	Switch to Pilot Rock Branch;
Briggs .....	Siding switches.
Sumner .....	East and west ends of siding.

**NO. 9 TURNOUT****WYOMING DIVISION**

CP835 .....	2 & Westvaco Running Track
-------------	----------------------------

## APPENDIX 4 SWITCHES

104 (R-1). Following governs handling of switches and normal position of switches at locations indicated:

### Nebraska Division

Switches will be set normally at:

- Oconee — for Norfolk Branch.
- Genoa — for Albion Branch.
- St. Paul — for Ord Branch.
- Yoder — for North Platte Branch.
- Valparaiso — for Beatrice Branch.

- Sidney Spring switch at west end of siding off No. 1 Track is equipped with facing point lock. Rule 517 applies.
- Owasco Spring switch at west end of siding is equipped with facing point lock. Rule 517 applies.
- Sterling Spring switch at east end of No. 1 Yard Track is equipped with facing point lock. When an eastward train or engine is stopped by signal on No. 1 Yard Track and no immediate conflicting movement is evident, movement may be made in compliance with Rule 517.

### Wyoming Division

- Denver Between 36th Street and Block Signal 18, and between DUT and Block Signal 13, during switching operation, main track switches may be left open except when otherwise instructed by yardmaster at 36th Street.
- CP508 Spring switch at MP 4 on eastward track and cut-off to DRGW Belt Line is equipped with facing point lock. Rule 517 applies.
- CP511 Yard switch of crossover between P4 & ACK lead — for ACK lead.
- Spring switch on yard lead, 500 feet east of switch connection to P4 main track — for south lead.
- Eastward movements over spring switch are governed by signal indication. When an eastward train or engine is stopped by this signal and control operator is unable to clear signal, in addition to complying with Operating Rules 269 and 275, inspect spring switch to know it is properly lined.
- Signs reading "Approach Section" are located 412 ft. east of spring switch on new South lead, new North lead and 400 ft. east of CTC signal on Old South lead. Westward trains or engines must not enter approach section unless signal displays indication permitting movement into CTC territory.

**The following hand operated switches must be returned to normal position after having been used:**

- Laramie Yard switch of crossover between siding and east yard lead, MP565.66, lined for east yard lead.
- Yard switch of crossover between siding and west yard lead, MP567.27, lined for west yard lead.
- Rawlins South siding to Center Service — for south siding.
- Ramsey Spur  
Black Buttes  
W. Thayer Movements over switches equipped with switch point indicators are governed as follows:
- | Aspect | Indication   |
|--------|--|
| Green  | Switch point fully closed in normal position.  |
| Yellow | Switch point fully closed in reverse position.   |
| Red    | STOP. Inspect switch point to know that switch point is fully closed and properly lined before moving over switch. |
- Point Of Rocks On Jim Bridger Spur, East Switch MP 1.93 — for east leg of wye.
- Rock Springs Yard switch of crossover between No. 2 main track and freight house lead — for freight house lead.

### Kansas Division

- Kansas City Armstrong Yard switch from receiving yard track 10 to East lead of train yard must be left lined for Receiving Yard Lead.
- Switch from Train Yard Lead to Train Yard Track 9 must be left lined for Track 9.

St. Joseph Branch Switches will be lined normal at Troy for UP main track.

Level Hastings Industrial Park  
Normal position for West Pillsbury Wye Switch is lined and locked for BN movement after switching industries. West Wye switch must be returned and locked for BN movement.

### Utah Division

- Becks Switches set normally at:  
Switch from advance track to Standard Oil Company crossover, for the crossover.
- North Yard All switches on West 16, for West 16.

Switch from south end of west lead to West 15, for West 15.

Before performing switching movements on west lead it must be known that West No. 15 switch is lined for Track 15 and switch must be left lined for West 15 when not in use.

All other hand-operated switches on west lead to and including new yard lead switch, for west lead.

Switch from West 7 to pole-west yard lead for West 7.

Switch from pole-west yard lead to West 6, for West 6.

All switches on a running rail, for running rail.

All switches on east lead from Bunjer switch to CP785, for east lead; and crossover switch from Bunjer track to east lead, for east lead.

Before shoving or switching cars into No. 9½ track from south end, the following will govern:

If movement is from east lead, West No. 1 switch must be lined for West No. 1 track.

If movement is from west lead, East No. 1 switch must be lined for East No. 1 track.

A member of crew must remain in vicinity of switch on respective leads to protect against any conflicting movements.

Before performing switching movements on east lead, it must be known that East No. 11 switch is lined for Track 11 and switch must be left lined for No. 11 track.

Grant Tower to  
9th South Street All main track switches between Grant Tower and 9th South, including switch at junction of Provo Subdivision and passenger main track for Provo main track.  
Garden tracks switch for passenger yard.

Ogden Crossover between Ice-House 7 and Ice-House 8 at south end of 28th Street, for Ice-House 8.

Yardmaster may authorize trains to line switches and move through Patterson Avenue area without receiving signal from switchtender.

Clearfield Bottom leg of wye, for north leg.

Freeport Syracuse Branch switch, for Freeport Center.

Geneva Inside switch at clearance point of Pipemill lead, for movement between Pipemill lead and U.S. Steel Co.

Provo All switches on west leg of wye, for west leg of wye; East end of Pipe Plant lead, for DRGW connection.

Warner East lead T.V. yard, for T.V. main track.

Faust Switch at east end of set-out track, for ramp track.

Lynndyl All switches on No. 1 track, for No. 1 track.

Iron Springs Switch at stem of wye, for east leg of wye.

Fibreboard Switch from lead to two highline bulk loading tracks, for highline.

Nellis Air Base  
Spur Switch at east end of run-around track, for run-around track.

Lovell Spur Switch at east end of run-around track, for run-around track.

Moapa Steam Plant Switch from Loop Track to north side Industrial Spur, for Loop Track.

Mead Lake Switch at stem of wye, for west leg of wye.

**California Division**

Arden Normal position of switch at tail track is for west leg of wye and must be left in this position after being used.

Blue Diamond Switch to runaway track must be kept lined and locked for runaway track and all switching movements made toward this track.

Henderson Normal position of switch from Boulder City Branch main track to BMI lead is for BMI lead. Switch target will continue to show red when switch is lined for lead.

Santa Fe Ave. Old UP main line switch — for Butte Street yard.

Colima Jct. For SP Yorba Linda Branch.

Fullerton Jct. For UP Anaheim Branch.

ATSF yard, west end Normal position of switch to inbound lead at Hobart is for inbound lead.  
Normal position of switch to east leg of wye at Hobart is for straight track.

Hobart Switch "A" (power operated and CTC controlled) west leg of Wye will be lined for straight track at all times, except just previous to a move down the Wye to the interlocking plant.  
Hand operated Switch "B" will be normally lined for a straight track move instead of a move down the east leg of Wye to the plant.  
The position of Control Switch "A" west leg of Wye will be indicated to Hobart Interlocking Tower so that operator will have advance information of a move toward the interlocking.

**Idaho Division**

Dry Valley Main track switch to west leg of Wye — for wye track.

Soda Springs Tail of Wye for east leg of Wye. All switches on running track — for running track.  
Tail of Wye switch on Conda Branch — for east leg of Wye.,

Pocatello All switches on north running track — for running track;  
Switch from north running track to Old Tie Plant track — for running track;  
Switch to Purina Mills — for stockyard lead;  
Switches on South running track, west of Bowl 40 — for south running track;  
Crossover on Old Montana main track opposite Steel Car Shop — for crossover.

McCammion Wye switch on Utah east siding — for siding

Don F.M.C. switch to runaway spur — for runaway spur.

Minidoka Switch at end of Twin Falls Branch main track — for siding.

Bliss Switch at end of North Side Branch main track — for siding.

Jerome East end of team track — for team track.

Nampa Idaho Northern switch on east leg of wye — for Idaho Northern Branch.

Nyssa Homedale Branch switch — for siding.

Ontario Oregon Eastern Branch switch — for siding.

Monida Switch at tail of wye — for east leg of wye.

Gay West leg of wye switch from main track must be left lined for wye.

Ashton Teton Valley Branch junction switch — for Teton Valley Branch.

Mackay Branch Aberdeen Jct. switch — Aberdeen Branch

**Oregon Division**

Joseph Main track switch, east leg of wye — for wye;  
Switch at stem of wye — for east leg of wye.

Hinkle Junction Switch, Umatilla Branch for west departure lead.  
Switch at stem of wye — for east leg of wye;  
Switch at No Hump Track, for hump lead.  
Spring switch — for Spokane main to wye.

Heppner When cars are left on main track for Kinzua Lumber Co., switch must be lined and locked for chip track to provide derail protection.

Albina Normal position of switch to Albina Fuel Co. Spur is for Barker Mfg. Co. Lead.  
Crossover switches on Tracks 21 to 26 inclusive must be left lined for straight track after having been used. Switches will be set normally at:  
Scale Lead switch for scale lead.  
New Main switch for Main Track 2.

Aberdeen Switch at end of double track — for eastward trains.

South Montesano Wye switch on Montesano Branch — for west leg of wye.

Colfax Moscow Branch switch — for Moscow Branch.

Hooper Jct. (Connell Branch) For line via Sixth Subdiv.

Seltice For line via Colfax.

Winona For line via Colfax.

Winona Tail of wye track for Colfax.

LaCrosse Connell Branch switch — for Connell Branch.

Tucannon For Tekoa Branch.

Walla Walla East wye switch Pendleton Branch — for Pendleton Branch.  
Wye switch Wallula Branch — for movement to east leg of wye.

Yakima, Pine Street For main switching lead.

Eastport Switch at tail of wye for east leg of wye.

## APPENDIX 5 SPEED SIGNAL RULES

240 (R-2). Signals at following locations have been changed to speed signals and Rules 240 through 240 (T) as contained in Union Pacific Operating and Maintenance of Way Signal Rules pamphlet dated July 1, 1976, will govern superseding Rules 240 (A) through 240 (P) as contained in Union Pacific Operating and Maintenance of Way Signal Rule Books effective May 1, 1972.

Speed signals approaching and through turnouts on Main Tracks and approaching and entering sidings are:

### Nebraska Division

First Subdivision:

Gibbon Jct.  
(CP175)

Keith

CP274-CP283

Second Subdivision:

CP291-CP508

### Wyoming Division

Second Subdivision

CP511

CP519

Borie

Dale Jct. westward only

CP547

CP549

CP565 to Rawlins

### Kansas Division

First Subdivision:

West Yard

East Topeka to West Menoken

Kenefick

Cook

Aikins

Duluth

Evans

Sullivan

Frankfort

Marysville

### Utah Division

First Subdivision:

CP785

Centerville

CP807

CP811

Bridge Jct.

Ogden-North Running Rail

McCammon

Second Subdivision:

\*\*\*\*Lynnndyl

\*\*\*\*Milford

### California Division

CP330 — CP326

\*\*\*\*Kelso

\*\*\*Sands

MP 159 — 168.6 (Main and Running Track)

### Wyoming Divn. Cont.

Third Subdivision:

Rawlins to CP702

CP766

CP801 to Green River

Fourth Subdivision:

Green River

Strawberry

East Riverdale

### Kansas Divn. Cont.

Second Subdivision:

Marysville to Gibbon Jct. CP175

### Utah Divn. Cont.

Third Subdivision:

\*\*\*\*Milford

\*\*\*\*Crestline

\*Richmond

\*\*\*\*Eccles

Caliente

\*\*\*\*Carp

\*\*\*\*Galt

Garnett

Provo Subdivision:

Payson

\*\*\*\*Starr

Nephi

\*\*\*\*Sharp

Juab

\*Parley

### Idaho Division

First Subdivision:

Granger

Moxa

Nutria

Opal

Kemmerer

Leele

Soda Springs

Alexander

Talmage

Bancroft

Topaz

McCammon

East Pocatello

Second Subdivision:

Minidoka

Adelaide

### Oregon Division

First Subdivision:

Huntington

Weatherby

Oxman

North Powder

Crooks

Lone Tree

CP289

Second Subdivision:

CP286

CP288

Hilgard

Motanic

Kamela

Meacham

Huron

Duncan

Bonifer

Gibbon

\*Reith

Nolin

CP189 Main Line 2

CP188 Main Line 1

CP186 Main Line 1

CP185 Main Line 1

### Idaho Divn. Cont.

Third Subdivision:

Hammett

Sebree

Cleft

Owyhee

Kuna

Fox

Caldwell

Notus

Parma

Payette

Weiser

Huntington

### Oregon Divn. Cont.

Third Subdivision:

CP184 Main Line 1 & 2

CP182 Main Line 1 & 2

Munley

Clarke

Boardman

Fourth Subdivision:

Crates

Mosier

Meno

Cascade Locks

Dodson

Bridal Veil

Sandy

Fifth Subdivision:

Fife

Sixth Subdivision:

Ayer Jct.

Page

Wallula

Wallula Jct.

Juniper

Cold Springs

Hinkle

\*NOTE — speed of 20 MPH must not be exceeded on sidings.

\*\*On siding between MP 321.2 and MP 322.9 — 20 MPH.

\*\*\*Speed of 30 MPH must not be exceeded on sidings.

\*\*\*\*Speed of 15 MPH must not be exceeded on sidings.

\*\*\*\*\*Speed of 20 MPH must not be exceeded on siding until engine has passed over hand operated switches.

\*NOTE — speed of 20 MPH must not be exceeded on sidings.

\*\*Speed of 30 MPH must not be exceeded on sidings.

\*\*\*Speed of 15 MPH must not be exceeded on sidings.

## APPENDIX 6 CTC RULES

**268 (R).** Train or engine must not use siding, spur or house track to clear tracks indicated below. When using such tracks, main track or siding must be continuously occupied or switch to track indicated must be left open. Rule 268 also applies in Speed Signal Territory. See Appendix 5.

Location	Track
<b>Nebraska Division</b>	
Beck .....	No. 1 Main Track
Hershey .....	No. 1 Main Track
Vарner.....	No. 1 Main Track
Sutherland.....	No. 2 Main Track except center siding
CP306 .....	No. 1 & 2 Main Tracks
Paxton .....	No. 1 & 2 Main Tracks
Roscoe.....	No. 1 & 2 Main Tracks
Ogallala.....	Dudden Spur & Stock Track
Brule.....	No. 2 Main Track
Big Springs.....	No. 1 & No. 2 Main Track except long crossover
East Barton.....	No. 2 Main Track
Julesburg.....	North Siding
Chappel.....	No. 1 & 2 Main Tracks except long crossover
Lodgepole.....	No. 1 & 2 Main Tracks
Sunol.....	No. 1 Main Track
Colton.....	No. 2 Main Track
Sidney.....	North 1-2 and Eltra Stub
Potter.....	No. 1 (west switch of north elevator track) & No. 2 Main Tracks
Jacinto.....	No. 2 Main Track
Dix.....	No. 1 Main Track
Kimball.....	No. 1 & 2 Main Tracks
Bushnell.....	No. 1 Main Track
Pine Bluffs.....	No. 1 & 2 Main Tracks
Tracy.....	No. 2 Main Track
Egbert.....	No. 2 Main Track & North Siding
Burns.....	No. 1 & 2 Main Tracks
Hillsdale.....	No. 2 Main Track
Archer.....	No. 2 Main Track

### Wyoming Division

Brighton (Western Sand Co. Siding)	Main Track
Dale .....	No. 2 Main Track
Colores .....	No. 1 Main Track
Forelle .....	No. 2 Main Track
Hadsell .....	No. 1 & 2 Main Tracks
Riner .....	No. 2 & North Siding
Uintah.....	No. 2 Main Track

### Kansas Division

Delia .....	Siding
Emmett .....	Siding
Aikins .....	Siding
Onaga .....	Siding
Lillis .....	Siding
Frankfort .....	Siding
Carleton .....	Siding
Edgar .....	Siding
Fairfield .....	Siding
Anan .....	Siding
Glenvil .....	Siding
Hastings (Leads and City Tracks)	Siding
Hayland .....	Siding

### Utah Division

MP 789.4 .....	No. 2 Main Track
MP 789.5 .....	No. 2 Main Track
MP 789.6 .....	No. 2 Main Track
Pioneer .....	No. 1 Main Track
Syro Steel .....	No. 2 Main Track
MP 802.5 .....	No. 1 Main Track
Kaysville .....	No. 1 Main Track
Roy .....	No. 2 Main Track
Lodjic .....	No. 1 Main Track
MP 408.9 .....	Main Track
Between MP P-752.8 and MP P-757.4	Main Track (except at electric locked switches)
MP 337.24 .....	Main Track

### California Division

CP330—MP329.08, 329.1, 329.27.....	North Running Track
------------------------------------	---------------------

### Idaho Division

Nutria (back track) .....	Siding
East Kemmerer (Spur Track).....	Siding
McCammon (Back Track).....	West Siding
Glenns Ferry (dock track).....	Main Track
Kuna (back track) .....	Siding

### Oregon Division

La Grande (La Grande Milling).....	Main Track
(Petrolane track).....	Main Track
Hood River (Standard Oil Spur).....	Main Track
(East Side Spur) .....	Main Track
Bridal Veil (Lumber Spur).....	Main Track
Kent (Industry Spur MP169.3) .....	Main Track
Andover (Industry Spur MP172.58) .....	Main Track

## APPENDIX 7 USE OF AIR BRAKES

806 (R). Air Brakes must be cut in and operative on all cars being handled on the following tracks:

Location	Minimum Requirements
<b>Nebraska Division</b>	
Woody	Between the "long tracks" and Kellogg Company's plant.
Columbus	Between sand pit and train yard, between train yard and BN transfer, and east switching limits.
Grand Island	Between train yard and New Holland lead, and between train yard and industrial lead crossing U.S. Highway 30.
Northport	Between train yard and BN transfer.
<b>Wyoming Division</b>	
Commerce City	Asmera or Continental Oil.
Cheyenne	Zone 6 (when handling three or more cars.) Ambridge or Government Yard (only when handling three or more cars.) All industry tracks east of viadock at MP 508.45 except Drill Track.
<b>Kansas Division</b>	
Kansas City	When handling cars to Fairfax from either leg of Fairfax wye.
Jeffrey Spur	When cars are handled at Jeffrey Energy Center.
<b>Utah Division</b>	
Pioneer	All cars handled in industrial area including Trumbull Asphalt spur and Fry Roofing spur.
Salt Lake City	Yard crews operating south of 9th South Street must have brakes cut in and operative on all cars. Crew must couple air and make air test as required by Air Brake Rule 1030(G) and must bleed cars in their cut upon arrival at South Yard. All cars handled in Utah Sand & Gravel plant. All cars handled to Salt Lake Auto Auction spur. All cars handled on Bee Line spur. All cars handled on Lerner-Pepper spur and Western Mining and Construction Company spur. All cars handled on Philips Oil warehouse trackage.
North Salt Lake	All cars being handled between these points. When handling cars on north or south main switching leads west of DRGW connection switch, sufficient air brakes must be cut in and operative to control movement on descending grade, and at least one air brake must be cut in and operative for each six loads handled.
Buena Vista	All cars being handled between these points.
Woods Cross	All cars handled when making movements on loading spurs serving General Refractories Company.
Freeport Center and Clearfield	All cars handled.
Provo, Geneva & Pipemill yards	All cars handled on all trackage.
Cutler	All cars handled between Moapa and steam generating plant.
Bauer	All cars handled.
Iron Mountain Branch	All cars handled.
Moapa	All cars handled.
Fibreboard Spur	All cars handled.
Lovell Spur, Ordnance Area	All cars handled.
Apex	All cars handled.
Arrolime	All cars handled.
<b>California Division</b>	
Las Vegas	When switching on lead, main track, or old main track at east end of yard, not over 10 cars consisting of ore, coal, sand, fuel oil or other heavy commodities may be pulled out of yard tracks to be switched, unless air brakes are cut in and operative on the 10 cars next to engine. When switching DeLuca Importing (Zone 4, Track 7) the following instructions govern: Track will hold three 60-ft. cars inside building. Air brakes must be cut in and operative. Electrically operated overhead door is controlled by Key Switch located to the left of the door. Key is kept in small metal box secured with switch lock. If door is found closed, it must again be closed before leaving, returning key to box.

Location	Minimum Requirements
Blue Diamond	Terminal test of air brakes as prescribed in Air Brake Rule 1025 must be made before departure. If necessary to move to main track when making up train, air brakes must be cut in and operative on all cars being handled and air brake test prescribed in Rule 1025 must be made on such cars before moving to main track.
East Los Angeles	Trailer ramp; Drott tracks.
Rioco	Oil loading platform.

### Idaho Division

Jerome	Between main track and uptown city yard.
Twin Falls	Between Twin Falls and McMillan.

### Use of Hand Brakes. Minimum Requirements.

806 (R-1). In addition to complying with Operating Rule 806 (A), hand brakes must be applied on cars as follows:

### Nebraska Division

Council Bluffs	All coal trains enroute connecting lines, must have a sufficient number of hand brakes to hold train regardless of the number of units attached to train. However, not less than 6 hand brakes must be set.
Omaha	Between 20th Street and Summit, not less than 6 hand brakes must be applied on east end of cuts of cars left standing on any track; at Summit, not less than 3 hand brakes must be applied on east end of cuts of cars left standing on Extension tracks 3 through 6. Not less than 4 hand brakes must be applied on the east end of the Pass, Long 1 and Long 2 tracks.
Woody	Not less than 4 hand brakes must be applied on the east end of the Pass, Long 1 and Long 2 tracks.
Northport	At Northport, eastward and westward coal trains must have a sufficient number of hand brakes to hold train regardless of number of units attached to the train; however, not less than 6 hand brakes must be set.

### Wyoming Division

Granite	At Granite gravel pit, hand brake must be set on all loads. On empty cars, hand brake must be set on every third car, with hand brake applied on car on each end of each cut.
---------	---

### Kansas Division

Bonner Springs	Center siding — sufficient hand brakes must be applied on both ends to hold cars. On all tracks, not less than 10 hand brakes must be applied on low end of cut of cars left standing on any track.
Jeffrey Spur	Trains left standing west of Highway 77 crossing, not less than 10 hand brakes must be applied on low end of train left standing.
Marysville	

### Utah Division

Utah Oil Field	Not less than 4 hand brakes must be applied on north end of each track. Crews switching against cars on these tracks must know that brakes are applied.
Salt Lake City, South Yard	Not less than 4 hand brakes must be applied on each cut of cars left in South Yard. This includes No. 7 lead, all tracks in classification yard, and all transfer tracks and depot tracks. When handling cars from North Yard to South Yard, one member of crew must take position on the rear end of the cars and remain at rear end of cars until movement has passed derail on the north end of South Yard Track, at which time he must immediately line derail in derailing position, and apply hand brakes. When cars are handled via Main track into South Yard, both switches from the Main track to crossover, are to be lined back, after movement is completed. At least 1 hand brake must be applied on north end of cars left standing on ¾ track, No. 5 lead, house lead, and on house tracks 1 and 2; Hand brakes must be applied on all cars left standing south of derail on ¾ track at material pile.
Salt Lake City, Freight House Area	Not less than 2 hand brakes must be applied on each end of each cut at trailer ramp. Hand brakes must be applied on all cars spotted for loading.
Becks	
Chevron Oil	

Location	Minimum Requirements
Ogden	<p>Trains arriving from east, when power is to be detached or train separated. (See Note.) Not less than 5 hand brakes on west end of train.</p> <p>Trains arriving Ogden from north or west, when power is to be detached or train separated. (See Note): Not less than 5 hand brakes immediately ahead of cabooses.</p> <p>Cars left on any track: Not less than 5 hand brakes on north or west end of cuts of cars.</p> <p>Defense Depot Ogden Classification Yard: Not less than 3 hand brakes on west end of cuts of cars on any track.</p> <p>Note: Train crews are responsible for applying required hand brakes upon arrival Ogden, unless outgoing crew or yard crew take immediate charge of the train.</p> <p>Hand brakes must not be released until outbound power is coupled to train and air brake system fully charged.</p>
Freeport	<p>Not less than 2 hand brakes must be applied on east end of all tracks in East Yard; not less than 4 hand brakes must be applied on east end of all tracks in West and New Yards; not less than 5 hand brakes must be applied on west end of North Main, South Main and west leg of wye.</p>
Clearfield	<p>Not less than 2 hand brakes must be applied on east end of all tracks.</p>
Milford	<p>Not less than 4 hand brakes must be applied on east end of train left standing on east or west end of siding clear of yard tracks.</p>
Provo	<p>Not less than 4 hand brakes must be applied on west end of all yard tracks in UP yards, Utah Railway joint trackage and DRGW interchange trackage.</p>
Clyde	<p>Hand brakes must be applied on each car set out.</p>
Cutler	<p>Hand brakes must be applied on each car left standing on west leg of old wye and lead to west leg of old wye.</p>
Iron Mountain Comstock Desert Mound Iron Springs	<p>Not less than 4 hand brakes per track must be applied on empties, not less than 8 hand brakes per track, must be applied on loads. In addition, at Desert Mound, not less than 3 hand brakes must be applied on upper end of tracks above tipple.</p>
Moapa	<p>Cars left standing on Run Around Tracks and Steam Plant Lead between siding and Steam Plant unloading facilities must have all hand brakes applied.</p> <p>Cars left standing on Steam Plant Balloon Tracks must have not less than 1 hand brake applied on low end.</p>
Lovell Spur Fibreboard Spur	<p>Hand brakes must be applied on all cars left standing.</p> <p>Not less than 5 hand brakes must be applied on low end of cars left standing on siding or on main track between switches.</p>
<b>California Division</b>	
Las Vegas	<p>Not less than 5 hand brakes must be applied on east end of trains or cuts of cars left standing on any track.</p>
Kelso	<p>Not less than 10 hand brakes must be applied on west end of any yard track, with or without engine attached.</p>
Yermo	<p>Not less than 3 hand brakes must be applied on east end of freight trains on arrival unless outgoing crew or yard crew take charge of train. In such case, if engine is detached, outgoing crew or yard crew must apply required hand brakes.</p> <p>Not less than 3 hand brakes must be applied on east end of cuts of cars left standing on any track, including Lend-Lease tracks.</p>
Riverside	<p>Not less than 1 hand brake must be applied on west end of cars left standing on any track.</p>
East Yard	<p>Not less than 6 hand brakes must be applied on west end trains or cuts of cars stopped east of Atlantic Blvd.</p> <p>Not less than 6 hand brakes must be applied on east end of trains or cuts of cars stopped west of Atlantic Blvd.</p> <p>Not less than 3 hand brakes must be applied on west end of trains or cuts of cars left on north or south drill tracks.</p>
Butte Street	<p>Not less than 3 hand brakes must be applied on Alameda St. end of cuts of cars delivered to SP.</p>

Location	Minimum Requirements
<b>Idaho Division</b>	
Soda Springs	<p>Hand brakes on all phosphorous cars when placed in Monsanto Plant or on Monsanto Siding.</p>
Pocatello PFE Shop Yard tracks Tie Plant Yard tracks Main tracks and all other tracks west of Gould Street	<p>Not less than 6 hand brakes on west end.</p>
Departure Yard tracks	<p>Not less than 2 hand brakes on east and west ends.</p>
Receiving Yard tracks	<p>Not less than 2 hand brakes on head end.</p>
<p>When placing cars in a receiving track containing other cars, coupling with other cars must be made. Hand brakes on either end of cars in receiving track must be released and brakes reapplied on head end of cars left in track.</p>	
Don	<p>Hand brakes must be applied on all loads left on FMC Coke track.</p>
Nampa Yard	<p>Icehouse and Storage Yard Tracks: Not less than 6 handbrakes on west end.</p> <p>East yard tracks: Not less than 2 hand brakes on west end.</p> <p>Short Yard tracks east of 14th Ave.: Not less than 1 hand brake on west end.</p> <p>Train yard tracks not less than one hand brake on west end.</p>
Fisher	<p>All tracks not less than one hand brake on west end.</p>
<b>Oregon Division</b>	
Albina, Business Car Spurs	<p>Hand brakes applied on all cars.</p>
Cook Elevator-Rivergate (Unloading Tracks)	<p>Not less than 2 hand brakes on east and west ends.</p>

**APPENDIX 8**  
**HOTBOX DETECTORS AND**  
**DRAGGING EQUIPMENT INDICATORS**

The following governs inspection of trains for dragging equipment and hotboxes:

**812 (R-1).** If there is an indication of dragging equipment, hold signal will indicate stop. Train dispatcher will advise where detector indicates dragging equipment is located in train. If car inspected indicates nothing dragging, 3 cars ahead and 3 cars behind the designated car must also be inspected. Train dispatcher must be advised result of inspection and crew must be governed by his instructions.

The above does not relieve employes from complying with existing rules and instructions governing inspection of trains.

**812 (R-4).** Red light will begin flashing if dragging equipment detector is actuated, and train must be stopped and inspected for dragging equipment. After inspection, when radio conditions permit, train dispatcher must be advised of results of inspection.

If train dispatcher advises detector is out of service, these instructions do not apply.

The above does not relieve employes from complying with existing rules and instructions governing inspections of trains.

**812 (R-5).** Locations of hotbox detectors are listed below. Readouts are located in Chief Dispatcher's Office except Riverdale readout located in Ogden Mechanical Department Office. The letters DEI preceding Mile Post location indicates dragging equipment indicator. The letters DEIO appearing in the Mile Post location indicates dragging equipment indicator only without hotbox detector. The number following the Mile Post indicates the special rule which governs that dragging equipment indicator: Example: DEI 434.6(R-1) denotes reference to Spl. Rule 812 (R-1) etc.

**812 (R-6).** On Wyoming Division, Third Subdivision, dragging equipment detectors are in service at MP 719.5 and MP 721.7. Dragging equipment indicator, a light with the letter "D" mounted on mast of Signal 7237. When "D" light is illuminated and signal displays Stop, train must be inspected for dragging equipment and train dispatcher advised of any exceptions found.

**\*NEBRASKA DIVISION**

Westward	Eastward
Scanner Mile Post	Scanner Mile Post
DEI 21.0(R-4)	DEI 499.0(R-4)
DEI 53.7(R-4)	DEI 475.2(R-4)
DEI 74.6(R-4)	DEI 454.3(R-4)
DEI 103.9(R-4)	DEI 434.4(R-4)
DEI 128.2(R-4)	DEI 416.1(R-4)
DEI 160.1(R-4)	DEI 397.1(R-4)
DEI 181.0(R-4)	DEI 372.5(R-4)
DEI 210.1(R-4)	DEI 353.1(R-4)
DEI 233.4(R-4)	DEI 335.2(R-4)
DEI 255.5(R-4)	DEI 316.4(R-4)
DEI 276.9(R-4)	DEI 297.7(R-4)
DEIO 281.1(R-4)	DEIO 285.5(R-4)
DEI 297.7(R-4)	DEIO 281.1(R-4)
DEI 316.4(R-4)	DEI 276.9(R-4)
DEI 335.2(R-4)	DEI 269.5(R-4)
DEI 353.1(R-4)	DEI 256.8(R-4)
DEI 372.5(R-4)	DEI 233.4(R-4)
DEI 397.1(R-4)	DEI 207.4(R-4)
DEI 416.1(R-4)	DEI 181.0(R-4)
DEI 434.4(R-4)	DEI 157.3(R-4)
DEI 454.3(R-4)	DEI 121.8(R-4)
DEI 475.2(R-4)	DEI 100.1(R-4)
DEI 499.0(R-4)	DEI 81.0(R-4)
	DEI 62.9(R-4)
	DEI 43.7(R-4)

DEI 297.7(R-4) on New South Running Track.

Strobe light governs No. 2 Track and South Running Track.

\*Red Light will begin flashing if dragging equipment detector is actuated and train must be stopped and inspected for dragging equipment. If Dispatcher is able to give locations in train of dragging equipment, the designated car or cars, as well as one car behind, must be inspected. If car inspection develops, nothing dragging, three cars ahead and three cars behind the designated car must also be inspected. Train Dispatcher must be advised results of the inspection and crew must be governed by his instructions.

NOTE: This does not relieve employes from complying with existing rules and instructions governing inspection of trains.

EXCEPTION: DEIO eastward and westward at M.P. 281.1 are governed by Special Rule 812(R-4).

**WYOMING DIVISION**

Westward	Eastward
DEI 545.4(R-4)	DEI 986.2(R-5)
DEI B557.7(R-4) (No. 3 track)	DEI 958.6(R-4)
DEI 576.0(R-4)	DEI 925.6(R-4)
DEI 595.8(R-4)	DEI 884.1(R-4)
DEI 613.6(R-4)	DEI 854.7(R-4)
DEI 630.9(R-4)	DEI 834.5(R-4)
DEI 651.6(R-4)	*DEIO 822.3(R-4)
DEI 672.9(R-4)	*DEIO 819.3(R-4)
DEI 692.2(R-4)	DEI 808.2(R-4)
DEI 713.4(R-4)	DEI 792.3(R-4)
DEIO 719.5(R-6)	DEI 767.7(R-4)
DEIO 721.7(R-6)	DEI 748.5(R-4)
DEI 733.4(R-4)	DEI 729.8(R-4)
DEI 754.0(R-4)	DEI 710.6(R-4)
DEI 773.8(R-4)	DEI 692.2(R-4)
DEI 792.3(R-4)	DEI 672.9(R-4)
DEI 808.2(R-4)	DEI 651.6(R-4)
*DEIO 819.3(R-4)	DEI 630.9(R-4)
*DEIO 822.3(R-4)	DEI 613.6(R-4)
DEI 834.5(R-4)	DEI 595.8(R-4)
DEI 867.7(R-4)	DEI 576.0(R-4)
DEI 909.1(R-4)	DEI B557.7(R-4) (No. 3 track)
DEI 936.9(R-4)	DEI 545.4(R-4)
DEI 968.8(R-4)	
DEI 986.2(R-4) (No. 2 Track)	

**KANSAS DIVISION**

Westward	Eastward
Scanner Mile Post	Scanner Mile Post
DEI 15.0(R-1)	DEI 275.6(R-1)
31.4	DEI 251.9(R-1)
53.0	232.3
87.3	213.5
104.5	192.3
123.4	177.5
DEI 141.4(R-1)	DEI 156.4(R-1)
DEI 156.4(R-1)	DEI 141.4(R-1)
177.5	123.4
192.3	104.5
213.5	87.3
232.3	46.9
DEI 251.9(R-1)	DEI 26.9(R-1)
DEI 275.6(R-1)	

**UTAH DIVISION**

DEI 751.0(R-1)	583.5	DEIO 470.0(R-4)	DEIO 410.4(R-4)
DEI 729.7(R-1)	566.4	DEIO 448.7(R-4)	DEIO 406.5(R-4)
703.3	546.4	DEIO 442.9(R-4)	DEI 388.2(R-4, R-1)
670.9	520.8	DEIO 434.6(R-4)	DEI 353.1(R-4, R-1)
644.0	DEIO 480.2(R-4)	DEIO 432.0(R-4)	
623.4	DEIO 474.0(R-4)	DEIO 430.2(R-4)	
604.6	DEIO 472.3(R-4)	DEI 423.0(R-4, R-1)	

**CALIFORNIA DIVISION**

324.2	233.4
292.7	209.2
272.7	175.3
256.0	42.4
	5.4

**IDAHO DIVISION**

20.5	313.4
DEI 61.4(R-1)	339.9
77.4	369.0 (No. 1 track)
106.6	DEI 379.8(R-1) (No. 2 track)
153.4	397.2
DEI 174.2(R-1)	417.9
233.5	DEI 445.1(R-1)
252.3	DEI 478.1(R-1)
DEI 268.8(R-1)	507.0
290.9	524.6

\*Strobes mounted on instrument case at these locations on north side of tracks and also on cable post on south side of track.

In addition to the strobes, there will be a recording on the dispatchers channel stating "Union Pacific Railroad dragging equipment indication Mile Post 822.3 or 819.3 track 1 or 2 — please stop your train." Light will come on dispatchers board as if a train crew depressed their button to contact dispatcher but crew will be recording.

**OREGON DIVISION**

\*\*Third and Fourth Subdiv.:

DEI 23.0(R-4)

DEI 52.9(R-4)

DEI 76.2(R-4)

107.5

125.0

142.9

160.5

\*First and Second Subdivs.:

DEIO 188.7(R-4)

194.9(R-4)

210.9(R-4)

DEIO 239.7 (Main Track and Siding) (R-4)

243.7(R-4)

DEIO 255.6

DEIO 259.3

DEIO 261.4(R-4)

DEIO 263.5(R-4)

DEIO 268.2 (Both Main Tracks)

DEIO 284.4(R-4)

301.8

DEIO 304.9(R-4)

333.2

372.0

\*Special Rule 812(R-4) applies to all dragging equipment detectors with the following revision:

When dragging equipment is indicated in train, the entire train must be inspected. If the Dispatcher gives the location in the train of dragging equipment, 3 cars ahead of and all cars behind the designated car must be inspected. All other dragging indicator rules are still in effect.

\*\*DEI detectors will be governed by Special Rule 812(R-4) and the following will apply: Red light will begin flashing if dragging equipment detector is actuated and trains must be stopped and inspected for dragging equipment. If Dispatcher is able to give locations in train of dragging equipment, the designated car or cars as well as one car behind must be inspected. If car inspection develops nothing dragging, 3 cars ahead and 3 cars behind the designated car must also be inspected. Train Dispatcher must be advised results of the inspection and crew must be governed by his instructions. This does not relieve employees from complying with existing rules and instructions governing inspections of trains.

**APPENDIX 9  
TRACK RESTRICTIONS**

899 (R). The following track restrictions apply:

ALL DIVISIONS	Track where curvature exceeds 22 degrees.	Only yard switchers and EMD units 1870 thru 1877 permitted.
	Industrial tracks where curvature exceeds 30 degrees.	In handling hydro-cushion cars, movement restricted to single car and unit.
	Industrial Trestles.	Engines not permitted.
<b>NEBRASKA DIVISION</b>		
Omaha	Alcohol Plant Scale Track ASR Coal Trestle	No Engines permitted. No Engines permitted beyond Span 15.
Beatrice Branch	All Trackage	Units listed in Special Rule 899 (R) may be operated. Four-axle cars not exceeding 315,000 lbs. gross weight can be handled between Beatrice and Marysville provided they are uniformly loaded and have 39'0" minimum center to center of trucks with 6'0" minimum axle spacing and have 38" minimum diameter wheels.
Lincoln	Scale Track	GP-35 and smaller units only.
Julesburg	City trackage	5000 horsepower units or greater not permitted.
Alda	Ordinance Track	GP-35 and smaller units only.
Albion Branch and Cedar Rapids Branch		C-3 and C-4 type covered hopper cars permitted on the Albion and Cedar Rapids Branches, not to exceed 263,000 lbs. gross weight. Locomotives with 6-axle trucks permitted on the entire Albion and Cedar Rapids Branches.
Ord Branch	Between St. Paul and Ord	Locomotives with 6-axle trucks, or cars with gross weight exceeding 220,000 lbs., must not exceed 15 mph.
Kearney Branch and Ord Branch	Between St. Paul and Ord	9000 class units not permitted.
Loup City Branch and Ord Branch	Between St. Paul and Ord	Four-axle cars not exceeding 263,000 lbs. gross weight with a 5' 10" minimum axle spacing may be handled subject to the following provisions:
Kearney Branch	Between Riverdale and Arnold	1) Axles must be equally loaded. 2) Speed must not exceed 15 MPH. 3) These cars must be separated from the locomotive, from each other, and from any other shipments exceeding 220,000 lbs. gross weight by at least three cars not exceeding 220,000 lbs. gross weight each.
Brownson	Industrial Warehouse Tracks	Gates must be closed and locked after entering area and again after leaving area. Switches to tracks not in service in building area are spiked.
Wypo	Wyoming Potato Co. Trackage	Less than 5000 horsepower units only at maximum speed of 5 MPH.
<b>WYOMING DIVISION</b>		
Denver	Track 8, Union Station	Units listed in Special Rule 899 (R) permitted at 5 MPH maximum speed.

Denver	Union Station	High or wide cars not permitted to move under umbrella sheds but must be handled on Track 5.
Greeley	Monfort Tracks	SD-24 units and units of 5000 horsepower or greater not permitted.
Brighton	GW Sugar	No engines permitted over flume bridge.
Lakeside Spur		SD-24 units and units of 5000 horsepower or more prohibited.
Valmont	PSC Track	No engines permitted on sharp curve at west end.
Boettcher	Cement plant	No engines permitted east of cement truck crossing on Track 7 or 200 feet. west of highline switch.
Cheyenne	C&S Yard	On Warren AFB Spur units with 6 wheel trucks not permitted on bridge between Interstate 25 and Warren AFB dock.
Granite	Loading Tipple	No engines or cabooses permitted.
Sinclair	Refinery	No engines permitted beyond gate.
Rock Springs	Sweetwater — No. 1 Safety Spur	No engine permitted
Stauffer, Alchem, Westvaco and TG Soda and Tenneco Spurs		SD-24 units and units of 5000 horsepower or more prohibited.

#### KANSAS DIVISION

First and Second Subdivision	Industry Tracks	Units listed in Special Rule 899 (R) permitted at 5 MPH maximum speed.
Fairfax	Owens Corning Hold Yard	Cars must be placed at least one car length from cable across Zone 10, tracks 11 thru 20.
Muncie Edwardsville	Auto Unloading Facility Nease Spur	5 MPH maximum speed. Units listed in Special Rule 899 (R) not permitted.
Forest Lake	Alongside high sand piles on sand loading track	No engines permitted.
Sunflower	Tracks 1, 2, 3, 4 & 5	No engines permitted beyond south cement plant paved driveway crossing.
Bonner Springs	House track	Units named in Special Rule 899 (R) must not go beyond track scale.
Lawrence Spur		Units listed in Special Rule 899 (R) permitted at 5 MPH maximum speed.
St. Joseph Branch	All Sidings and other inside tracks	5 MPH maximum and cars in excess 263,000 lbs. prohibited.
Between Marysville and Gibbon Jct.	Elevator and Industry Tracks	Units listed in Special Rule 899 (R) permitted at 5 MPH maximum speed.
Grand Island Branch	All Tracks	Hastings to Grand Island, cars in excess of 263,000 pounds prohibited.
<b>DENVER CUT-OFF MP 10.8</b>		No engines permitted beyond 2 car lengths from east end of loading dock.
Denver Cut-Off	Between Rossville and Denver	Units listed in Special Rule 899 (R) may be operated on sidings at 5 MPH maximum.
Manhattan Kanopolis	Mid-Quinn Spur Salt Spur Industry Track and Yard Tracks	No engines permitted. 5 MPH maximum speed.

Ellsworth	South Elevator SLSF Transfer Track	5 MPH maximum speed. 5 MPH maximum speed.
Wilson	Mill Spur	5 MPH maximum speed.
Bunker Hill	House	5 MPH maximum speed.
Limon	CLK Tracks	5 MPH maximum speed.
<b>Plainville Branch</b>	All Sidings	5 MPH maximum speed and cars in excess 263,000 pounds prohibited.
Quartzite	Cement Track	No engines permitted beyond loading ramp.
<b>Solomon Branch</b>	All Sidings	5 MPH maximum speed and cars in excess 263,000 pounds prohibited.
<b>McPherson Branch</b>	All Sidings	5 MPH maximum speed and cars in excess 263,000 pounds prohibited.

#### UTAH DIVISION

Units with eight axles not permitted on set-out tracks at the following locations:

Milford (set-out track off west drill)	Elgin Stine Boyd Kyle Rox Valley Las Vegas Industrial Park Nevada Industrial Park
Evona Branch	All six-axle locomotives may be operated but must not be used as multiple units over Weber River bridge at MP 0.02.
Salt Lake City	Engines must not move through One Spot Rip Track. Eight axle-type units must not be operated on SLGW tracks on South Temple St.
Murray	Units must not move over under-track hopper on Gibbons and Reed Spur. Salt Lake Terminal area and Pioneer Industrial area have a number of curves in excess of 16 degrees. Before moving or switching on these industrial tracks, it must be known that curvature of track does not exceed maximum permitted. List of all tracks in these areas that have curvature in excess of 16 degrees will be maintained in Terminal Superintendent's circular notice book and will be posted in Salt Lake City Terminal area yard offices.
	<b>Note:</b> Referring to Operating Rule 805 (D) and Special Rule 805 (R), curvature on following tracks is in excess of 16 degrees:
Woods Cross	New Team Track* ..... 22° Phillips Oil Spur ..... 17°30'
Kaysville	Church Warehouse ..... 20°
Clearfield	Woods Cross Canning ..... 17°24'
Hyrum	Valley Rendering Spur* ..... 20°
Logan	Anderson Coach Spur ..... 20°40' Sears Warehouse ..... 22°
Garland	Sugar Factory Rock Track ..... 20° Wet Wash Track ..... 20°
Buena Vista	Western Mining & Constr. Co. .... 23°30'
Industrial Center	Eaton Metal Spur ..... 22° Gate City Steel ..... 22° Deere & Company Spur ..... 19° Turf Equipment Spur ..... 34° Madsen Toy Spur ..... 23° Souvall Brothers Spur ..... 20° Western Electric Spur ..... 24°15' Overmeyer Warehouse ..... 22° Stokermatic Spur ..... 20°
Pipemill	Track 2 ..... 16°40' Track 3 ..... 20°
Provo	Hide House & Spur ..... 30° Texas Oil Spur ..... 28° Auto Dock ..... 30° Commercial Welding — South Track ..... 16°30' North Track ..... 23°40'
Tooele Army Depot, Warner, or Deseret Chemical Warfare Depot, Clover	When necessary to go beyond derail on stem of wye, member of crew must communicate with agent at Warner if he is on duty, or with train dispatcher in other cases, who will arrange for U.S. Government yardmaster to supervise the movement.
Nellis	Shell Oil Spur ..... 18°

\*Only single unit permitted.

EMD SD-45 units No's. 1-50 must not be operated on Malad Branch.

No engines are permitted on the following tracks:

Kaysville	Deseret Mill and Elevator Spur over grain pit.
Malad	Beyond concrete slab installed on coal spur at Oneida County Grain Growers.
Franklin	Butters Coal Spur pit.
Presto	West end lime rock track.
Whitney	Over dump pit on highline at sugar factory.
Pleasant Grove	Plant trackage which connects to United Concrete Pipe Spur.
Hardy Beet Spur	Loading track beyond point 700 ft. east of switch.
Provo	Pipe Plant Highline, beyond sign at underpass.
Nephi	Pit on track 1 at rubber plant.
Industrial Center	Coal unloading bin at heating plant building No. 15; Track through thaw shed at Filtrol Corp.
Milford	Jefferson Coal Spur, inside of gate.
Caserton	Main Mill Spur over track hopper and under loading tipple.
Prince Branch	All tracks beyond MP 8.7.

#### CALIFORNIA DIVISION

Units listed in Special Rule 899 (R) may be operated as follows:

Boulder City Branch  
Blue Diamond Spur  
Cima, loading tracks

No units are permitted to operate on the following tracks:

Boulder City Machine Shop track 7  
Blue Diamond In building at board plant, track 2

Diesel units with 8-wheel trucks must not be operated through turnouts as follows:

Basin	Cleaning track
Sloan	Hi-line track
Bracken	Cinderlite track
Boulder City Branch	Industrial Asphalt Spur

Reference Special Rule 899 (R), units listed may be used on San Pedro Branch and on SP connection to bulk unloader.

No units are permitted to operate on following tracks:

San Pedro Branch	MP 10.2 over trestle Dayton Foundry Co. Spur.
Manuel	Units with 6- or 8-wheel trucks must not be operated on industry trackage.
Anaheim Branch	MP 2.6 over trestle on Old Sunkist Packing Co. Spur.

Diesel units with 8-wheel trucks must not be operated through turnouts as follows:

Pico Rivera	House track No. 2
City of Industry	House track No. 6
Walnut	Packing house track No. 4
Pomona	Freight house tracks A-34 and A-36
Pedley	East leg of wye

#### IDAHO DIVISION

Units must not be operated on following tracks:

Grace Branch	GP 30's units 700-739B and GP 38-2 units 2000-2059 may operate at 5 MPH less than timetable speed.
Pocatello	6900 class units must not use Enginehouse Track 9.

The following units can be operated across Bridge 20.1, provided speed does not exceed 10 MPH:

Twin Falls Branch	SD-24 units 400-448 C-30-7 units 2400-2429 U-28-C units 2800-2809 U-30-C units 2810-2959 SD-40 units 3000-3488, 8000-8074.
-------------------	--

#### OREGON DIVISION

Kamela	5000 HP units or larger must not be operated over wye track.
Lime	5000 HP units or larger must not be operated on High-line Track.
Bonneville, Powerhouse Spur	Movement of hydro-cushion cars is restricted to one car and units account of curvature.
Ordnance yard	Lead track, west area yard and tracks 7 through 21 in east area yard are restricted to 5 MPH.
Rufus	John Day Dam Spur, units coupled in multiple must not move beyond derail.
Tacoma	5000 HP units or larger must not be operated on Union Depot trackage.

Hinkle

#### Master and Group Retarders

All units are prohibited from movement through, except those modified SD-24 and SD-40 type units assigned; Units Nos. 400-401-404-420; Units 3000-3007.

#### Scale By-Pass Track

All units must operate over dead rail of weigh in motion scales located on Hump Lead.

## APPENDIX 10 CLOSE CLEARANCES

900 (R). There are close side or overhead clearances along main tracks at locations shown below. Additional close clearances may be expected at platforms, buildings and other structures along any side, industry or other track.

### NEBRASKA DIVISION

**Mile Post**  
**First Subdivision:**  
 1.03 Signal Bridge  
 1.33 Signal Bridge  
 1.88 Signal Bridge (No. 1 Trk)  
 2.09 Bridge  
 2.30 Dwarf Signal (No. 1 Trk)  
 2.90 Viaduct (No. 1 Trk)  
 3.10 Train Order Transmitter  
 4.67 Viaduct (No. 2 Trk)  
 5.59 Bridge  
 7.94 Bridge  
 17.75 Bridge  
 18.82 Bridge  
 19.88 Bridge  
 20.77 Bridge  
 23.86 Bridge  
 27.98 Train Order Transmitter  
 44.71 Bridge  
 84.51 Train Order Transmitter  
 86.49 Bridge  
 143.53 Bridge  
 146.20 Train Order Transmitter  
 158.00 Bridge  
 189.08 Train Order Transmitter  
 205.95 Bridge  
 248.78 Train Order Transmitter

**Old Main Line:**  
 5.31 Viaduct (WB Trk)  
 9.78 Bridge  
 11.18 Bridge  
 11.77 Handrails  
 11.93 Switch Stand  
 12.64 Bridge  
 18.71 Bridge  
 24.76 Bridge  
 25.57 Handrails

**Beatrice Branch:**  
 2.10 Bridge  
 19.85 Bridge  
 20.18 Bridge  
 24.70 Bridge  
 26.52 Bridge  
 38.55 Bridge  
 41.61 Hand Rails  
 45.81 Bridge  
 55.71 Bridge  
 56.60 Bridge  
 57.07 Train Order Transmitter  
 63.93 Bridge  
 65.76 Bridge  
 66.21 Bridge  
 68.50 Bridge  
 87.96 Bridge  
 90.11 Bridge  
 93.27 Hand Rails  
 100.50 Bridge  
 103.25 Bridge  
 107.80 Bridge  
 109.23 Bridge  
 118.83 Bridge  
 121.21 Bridge  
 124.29 Bridge

**Mile Post**  
**Stromsburg Branch:**  
 0.34 Bridge

**Norfolk Branch:**  
 47.85 Bridge

**Albion Branch:**  
 8.78 Bridge  
 9.82 Handrails  
 15.90 Bridge

**Cedar Rapids Branch:**  
 12.96 Bridge  
 22.55 Bridge  
 23.58 Bridge

**Ord Branch:**  
 20.99 Bridge

**Second Subdivision:**  
 365.35 Train Order Transmitter  
 390.57 Bridge  
 403.87 Bridge  
 406.57 Handrails  
 419.57 Bridge  
 426.86 Bridge  
 506.33 Bridge

**North Platte Branch:**  
 28.73 Handrails  
 70.46 Bridge  
 143.81 Bridge  
 164.86 Bridge  
 181.02 Bridge  
 185.81 Bridge  
 189.43 Bridge  
 195.61 Bridge

**North Platte Cut-Off:**  
 27.08 Tunnel  
 51.35 Bridge

**Third Subdivision:**  
 7.05 Bridge  
 33.18 Bridge  
 48.71 Bridge  
 57.08 Signal  
 58.10 Signal  
 132.53 Bridge  
 134.80 Signal  
 142.40 Signal  
 46.16 Train Order Transmitter between  
 LaSalle depot and siding

### WYOMING DIVISION

**Mile Post**  
**First Subdivision:**  
 2.21 Signal (EB Trk)  
 15.58 Bridge  
 16.36 Bridge  
 46.32 Dwarf Signal

**Fort Collins Branch:**  
 26.79 Bridge

**Second Subdivision:**  
 546.67 Tunnel  
 567.86 Bridge  
 573.35 Bridge

**Third Subdivision:**  
 806.42 Bridge  
 814.28 Bridge  
 814.83 Bridge

### KANSAS DIVISION

**Mile Post**  
**First Subdivision:**  
 0.88 Bridge  
 1.83 Dwarf Signal  
 2.25 Dwarf Signal  
 2.35 Dwarf Signal  
 2.51 Dwarf Signal  
 2.54 Dwarf Signal  
 3.33 Dwarf Signal  
 3.41 Dwarf Signal  
 3.60 Dwarf Signal  
 3.75 Dwarf Signal  
 6.15 Dwarf Signal  
 6.87 Bridge  
 27.86 Bridge  
 34.35 Bridge  
 35.95 Bridge  
 47.40 Bridge  
 48.55 Bridge  
 52.60 Bridge  
 60.88 Bridge  
 64.88 Bridge  
 76.11 Bridge  
 79.61 Bridge  
 80.34 Bridge  
 81.23 Bridge  
 88.69 Bridge  
 89.58 Bridge  
 93.03 Bridge  
 94.26 Bridge  
 95.70 Bridge  
 106.05 Bridge  
 106.96 Bridge  
 109.63 Bridge  
 117.66 Bridge  
 121.49 Bridge  
 126.31 Bridge  
 128.27 Bridge  
 133.92 Bridge  
 134.84 Bridge  
 136.33 Bridge  
 144.06 Bridge  
 144.54 Bridge  
 146.61 Bridge

**St. Joseph Branch:**  
 0.37 Bridge  
 5.35 Bridge  
 5.63 Bridge  
 6.34 Bridge  
 7.14 Bridge  
 7.62 Bridge  
 25.74 Bridge  
 36.78 Bridge  
 61.54 Bridge  
 76.22 Bridge

**Bestwall Spur:**  
 0.72 Bridge  
 5.0 Bridge

**Mile Post**  
**Fourth Subdivision:**  
 902.70 Tunnel (No. 2 Trk)  
 917.77 Signal (WB Trk)  
 930.13 Tunnel (EB Trk)  
 931.12 Tunnel (EB Trk)  
 931.27 Tunnel (WB Trk)  
 935.53 Tunnel (EB Trk)  
 951.42 Pipe (EB Trk)  
 960.41 Bridge  
 961.50 Handrails (WB Trk)  
 961.58 Signal (WB Trk)  
 963.13 Bridge  
 963.21 Tunnel  
 963.56 Bridge (EB Trk)  
 964.01 Tunnel  
 978.25 Bridge (No. 2 Trk)  
 978.42 Bridge (No. 2 Trk)  
 982.09 Tunnel (No. 1 Trk)  
 984.05 Bridge (No. 2 Trk)

**Mile Post**  
**Second Subdivision:**  
 149.30 Bridge  
 157.30 Hand Rails  
 175.59 Hand Rails  
 180.78 Hand Rails  
 184.84 Hand Rails  
 191.18 Hand Rails  
 192.52 Hand Rails  
 194.54 Hand Rails  
 195.00 Hand Rails  
 199.16 Hand Rails  
 199.56 Hand Rails  
 199.68 Hand Rails  
 200.33 Hand Rails  
 207.35 Hand Rails  
 213.97 Hand Rails  
 215.46 Hand Rails  
 218.72 Hand Rails  
 219.33 Hand Rails  
 262.64 Hand Rails  
 263.51 Hand Rails  
 282.08 Hand Rails

**Denver Cut-Off:**  
 84.29 Bridge  
 96.72 Bridge  
 96.86 Bridge  
 97.13 Bridge  
 97.28 Bridge  
 99.66 Bridge  
 117.61 Bridge  
 137.18 Bridge  
 143.58 Bridge  
 148.84 Bridge  
 151.55 Bridge  
 156.43 Bridge  
 157.27 Bridge  
 160.27 Bridge  
 164.07 Bridge  
 170.76 Bridge  
 173.62 Bridge  
 181.12 Bridge  
 187.12 Bridge  
 195.06 Bridge  
 201.94 Bridge  
 202.44 Bridge  
 274.01 Bridge  
 285.04 Bridge  
 290.62 Bridge  
 405.61 Bridge  
 427.80 Bridge  
 514.94 Bridge  
 518.82 Bridge  
 522.79 Bridge  
 534.63 Bridge  
 592.09 Bridge  
 597.02 Bridge  
 602.15 Bridge  
 602.27 Bridge  
 607.80 Bridge

**Solomon Branch:**  
 8.21 Bridge  
 23.65 Bridge

**McPherson Branch:**  
 21.42 Bridge

**Plainville Branch:**  
 1.16 Bridge  
 10.69 Bridge  
 33.36 Viaduct  
 33.45 Viaduct  
 135.22 Bridge  
 138.58 Bridge  
 139.67 Bridge  
 140.96 Bridge  
 141.56 Bridge  
 143.82 Bridge  
 145.06 Bridge  
 145.91 Bridge  
 150.46 Bridge  
 151.49 Bridge  
 154.40 Bridge

**UTAH DIVISION****Mile Post**

**First Subdivision,  
Salt Lake to Ogden:**  
817.9 Bridge

**First Subdivision,  
Ogden to McCammon:**  
45.20 Tunnel No. 15  
45.98 Rock Cut  
46.12 Rock Cut

**Second Subdivision:**  
601.13 Bridge

**Provo Subdivision:**  
P-735.76 Overpass  
P-754.42 Bridge

**Midvale Spur:**  
0.34 Overpass

**Hill Field Branch:**  
0.06 Bridge

**Mile Post****Third Subdivision:**

395.42 Bridge  
397.04 Bridge  
397.32 Bridge  
406.55 Bridge  
407.09 Bridge  
408.97 Bridge  
409.16 Bridge  
414.11 Bridge  
419.30 Bridge  
430.68 Bridge  
431.82 Bridge  
433.47 Bridge  
437.22 Bridge  
441.90 Tunnel  
444.56 Bridge  
447.89 Bridge  
455.97 Tunnel  
458.56 Bridge  
462.78 Tunnel  
463.26 Tunnel  
468.06 Bridge  
469.07 Bridge  
469.33 Bridge  
469.95 Bridge  
470.91 Bridge  
471.28 Bridge  
471.38 Tunnel  
471.46 Bridge  
471.74 Bridge  
502.09 Bridge  
527.60 Bridge

**Pioche Branch:**  
0.68 Bridge

**Mead Lake Branch:**  
3.40 Rock Cut  
5.64 Rock Cut  
16.87 Handrails  
17.15 Retaining Wall

**CALIFORNIA DIVISION****Mile Post**

**First Subdivision:**  
161.90 Train Order Transmitter  
191.18 Bridge  
191.90 Bridge  
192.27 Bridge  
195.44 Handrails  
196.17 Bridge  
243.96 Handrails  
250.69 Handrails  
267.25 Handrails

**Boulder City Branch:**  
9.91 Switch Stand  
10.14 Handrails

**Second Subdivision:**  
3.42 Dwarf Signals (EB Trk)  
9.47 Bridge  
10.80 Bridge  
28.22 Bridge  
32.82 Posts  
52.45 Handrails  
55.74 Siphon Walls  
55.86 Overpass

**Mile Post**

**Anaheim Branch:**  
3.05 Bridge

**San Pedro Branch:**  
8.52 Bridge  
22.02 Overpass  
23.08 Bridge

**Pasadena Branch:**  
0.04 Signal Bridge (WB Trk)  
0.91 Dwarf Signal  
1.02 Dwarf Signal  
2.95 Bridge

**IDAHO DIVISION****Mile Post****First Subdivision:**

1.61 Bridge  
5.33 Bridge  
11.35 Bridge  
21.94 Bridge  
26.81 Bridge  
28.11 Bridge  
28.81 Bridge  
30.27 Bridge  
32.31 Bridge  
36.71 Bridge  
36.99 Bridge  
37.78 Bridge  
37.94 Bridge  
38.95 Bridge  
55.08 Bridge  
82.93 Bridge  
84.04 Bridge  
84.24 Bridge  
91.03 Bridge  
95.94 Bridge  
96.97 Bridge  
98.66 Bridge  
101.08 Bridge  
106.32 Bridge  
107.28 Bridge  
119.86 Bridge  
126.40 Bridge  
129.92 Bridge  
131.44 Bridge  
133.65 Bridge  
136.97 Bridge  
138.64 Bridge  
139.96 Bridge  
178.61 Bridge  
184.83 Bridge  
198.65 Bridge  
202.34 Bridge  
203.02 Bridge

**Grace Branch:**  
5.33 Bridge

**Second Subdivision:**  
331.27 Bridge  
333.45 Bridge  
339.80 Bridge

**Twin Falls Branch:**  
20.10 Bridge

**Northside Branch:**  
21.39 Bridge  
67.05 Cattle Guard

**Third Subdivision:**  
447.80 Bridge  
448.13 Bridge  
465.01 Bridge  
466.74 Bridge  
486.83 Bridge  
487.70 Bridge  
494.57 Bridge  
499.82 Bridge  
500.17 Bridge  
502.36 Bridge  
515.68 Bridge  
536.38 Bridge

**Mile Post**

**Boise Cut-Off:**  
B-446.07 Bridge

**Idaho Northern Branch:**  
33.27 Tunnel No. 2  
38.56 Tunnel  
49.23 Bridge  
54.67 Cattle Guard  
77.34 Tunnel No. 4  
83.72 Tunnel  
89.59 Bridge

**Oregon Eastern Branch:**

11.47 Bridge  
29.27 Bridge  
53.71 Tunnel  
61.75 Bridge  
67.84 Bridge  
71.16 Tunnel  
71.21 Bridge  
72.32 Bridge  
83.79 Bridge  
84.58 Bridge  
84.99 Bridge  
95.32 Bridge

**New Meadows Branch:**  
51.49 Bridge

**Fourth Subdivision:**

156.96 Bridge  
166.97 Bridge  
177.62 Bridge  
192.35 Bridge  
202.73 Bridge  
263.48 Bridge  
302.73 Bridge  
319.12 Bridge  
351.28 Bridge

**Mackay Branch:**

1.52 Bridge  
35.00 Rock Cut

**Yellowstone Branch:**

2.53 Bridge  
13.38 Bridge  
18.44 Bridge  
19.55 Bridge  
44.40 Bridge  
51.13 Standpipe

**East Belt Branch:**

19.11 Bridge  
19.37 Bridge

**OREGON DIVISION****Mile Post****First Subdivision:**

343.94 Bridge  
 344.29 Bridge  
 366.74 Bridge  
 372.02 Bridge  
 373.76 Bridge  
 373.90 Bridge  
 376.11 Bridge  
 378.19 Bridge  
 378.75 Bridge  
 378.77 Bridge  
 379.62 Bridge  
 380.22 Bridge  
 380.44 Bridge  
 382.02 Bridge  
 383.27 Bridge  
 384.42 Bridge  
 385.02 Bridge  
 385.19 Bridge  
 385.95 Bridge  
 386.62 Bridge  
 386.92 Bridge  
 387.36 Bridge  
 387.75 Bridge  
 388.40 Bridge

**Second****Subdivision:**

198.26 Bridge  
 201.55 Bridge  
 204.15 Tunnel  
 204.91 Bridge  
 205.84 Bridge  
 206.21 Bridge  
 214.42 Bridge  
 226.86 Bridge  
 230.57 Bridge  
 238.67 Bridge  
 247.22 Bridge  
 251.18 Bridge  
 252.52 Bridge  
 257.18 Bridge  
 280.01 Bridge  
 281.29 Bridge

**Joseph Branch:**

2.48 Bridge  
 16.00 Rock Cut  
 16.50 Rock Cut  
 16.69 Rock Cut  
 29.15 Rock Cut  
 29.25 Rock Cut  
 31.85 Rock Cut  
 33.04 Rock Cut  
 35.78 Rock Cut  
 36.54 Rock Cut  
 39.86 Rock Cut  
 40.06 Rock Cut  
 40.44 Rock Cut  
 40.58 Rock Cut  
 40.80 Rock Cut  
 41.43 Rock Cut  
 41.82 Rock Cut  
 42.50 Rock Cut  
 42.69 Rock Cut  
 44.35 Rock Cut  
 45.42 Rock Cut  
 47.20 Rock Cut  
 47.65 Rock Cut  
 48.36 Rock Cut

**Pilot Rock Branch:**

0.16 Bridge

**Third Subdivision:**

99.28 Bridge  
 114.09 Bridge

**Umatilla Branch:**

10.67 Bridge

**Hepner Branch:**

33.55 Bridge

**Mile Post****Fourth Subdivision:**

0.43 Bridge  
 3.79 Viaduct  
 4.14 Viaduct  
 8.19 Bridge  
 10.25 Bridge  
 15.82 Bridge  
 21.09 Tunnel  
 26.01 Bridge  
 29.65 Bridge  
 31.85 Bridge  
 32.15 Bridge  
 39.58 Tunnel  
 39.90 Bridge  
 61.03 Bridge  
 63.32 Bridge  
 66.87 Tunnel  
 69.40 Bridge

**Via Kenton:**

4.59 Tunnel  
 13.02 Bridge  
 14.54 Bridge  
 21.82 Bridge

**Fifth Subdivision:**

4.59 Tunnel  
 144.75 Viaduct  
 144.92 Bridge  
 146.93 Bridge  
 180.15 Bridge  
 180.45 to 182.97 Catenary Poles  
 183.08 Bridge  
 147.4 to 173.7 Overhead  
 Power Lines

**Grays Harbor Branch:**

1.26 Bridge  
 4.35 Bridge  
 53.33 Bridge

**Olympia Branch:**

5.23 Tunnel  
 5.26 Manhole  
 5.75 Tunnel  
 6.75 Overpass

**Sixth Subdivision:**

202.16 Bridge  
 231.83 Tunnel  
 275.08 Tunnel  
 275.50 Tunnel  
 275.97 Tunnel  
 276.20 Tunnel  
 276.48 Tunnel  
 278.36 Tunnel  
 284.69 Bridge  
 286.76 Bridge  
 292.07 Tunnel  
 294.37 Tunnel  
 305.62 Bridge  
 325.70 Bridge  
 337.20 Bridge  
 352.13 Bridge

**Wallula Branch:**

14.53 Handrails  
 19.10 Handrails

**Pendleton Branch:**

36.86 Bridge  
 46.46 Bridge  
 74.12 Viaduct

**Mile Post****Yakima Branch:**

4.38 Bridge  
 7.44 Bridge  
 11.52 Bridge  
 14.16 Bridge  
 16.06 Bridge  
 27.80 Bridge  
 35.89 Bridge  
 56.83 Bridge  
 58.04 Bridge  
 58.19 Bridge  
 73.03 Bridge  
 73.20 Bridge  
 73.30 Bridge  
 89.35 Bridge

**Tekoa Branch**

77.23 Bridge  
 90.27 Bridge  
 93.01 Bridge  
 98.03 Bridge  
 115.79 Bridge  
 138.52 Bridge  
 143.67 Bridge  
 154.60 Rock Cut  
 163.56 Bridge  
 164.06 Bridge

**Tucannon****Branch**

4.92 Handrails

**Connell Branch:**

7.93 Handrails  
 8.50 Handrails  
 15.13 Bridge

**Pleasant Valley****Branch**

1.51 Bridge

**Moscow Branch**

8.54 Bridge  
 18.77 Bridge  
 18.97 Bridge  
 20.54 Handrails

**Wallace Branch**

23.45 Bridge  
 55.56 Bridge  
 58.01 Bridge  
 62.14 Bridge  
 62.64 Handrails  
 63.48 Bridge  
 72.59 Bridge  
 79.36 Bridge

**Spokane Subdivision:**

0.63 Bridge  
 7.24 Overpass  
 41.14 Overpass  
 41.17 Overpass  
 85.90 Bridge  
 101.16 Overpass  
 109.90 Bridge  
 114.59 Tunnel No. 1  
 114.96 Tunnel No. 2  
 117.01 Tunnel No. 4  
 130.30 Bridge  
 136.05 Bridge

**Coeur D'alene Branch:**

6.73 Overpass  
 6.76 Overpass  
 6.91 Overpass  
 8.26 Overpass

**APPENDIX 11**  
**TONNAGE RATINGS FOR ONE LOCOMOTIVE UNIT**  
**FOR FREIGHT TRAINS AVERAGING 50 GROSS TONS PER CAR**  
**RATINGS APPLY AT THE INDICATED MINIMUM CONTINUOUS SPEED**

EASTERN DISTRICT	100-129	131-349	305-347 470-499	400-448	450-459	700-739B 800-875	740-763	1400-1409	2000-2059	2810-2959 2400-2539	3000-3806 99	1-50 60-65	6900-6948	9000-9005
	1500 HP EMD GP7	1750 HP EMD GP9	2000 HP GP9M GP20	2400 HP EMD SD24	1500 HP EMD SD7	2250 HP EMD GP30	2500 HP EMD GP35	2500 HP EMD SDP35	2000 HP GP38-2	3000 HP U30C C30-7	3000 HP SD40 SD40-2	3600 HP EMD SD45	6600 HP EMD DD40X	3500 HP EMD GP40X
	12 MPH	12 MPH	14 MPH	10 MPH	6 MPH	12 MPH	12 MPH	12 MPH	11 MPH	10 MPH	11 MPH	11 MPH	11 MPH	11 MPH
Co. Bluffs To Valley .....	2250	2650	2550	4050	2700	2950	3000	3650	3150	5250	4900	4950	5800	2900
Valley To No. Platte .....	3650	4250	4100	6550	4350	4750	4850	5900	5050	8500	7850	7950	9350	4700
No. Platte To Sidney .....	2600	3000	2950	4650	3100	3400	3450	4200	3600	6050	5600	5650	6650	3300
Sidney To Cheyenne .....	2000	2350	2250	3600	2350	2600	2650	3250	2800	4650	4300	4350	5150	2550
Valley To Valparaiso .....	1250	1450	1450	2250	1450	1650	1700	2050	1750	2950	2750	2750	3200	1600
Valparaiso To Lincoln .....	3650	4250	4100	6550	4350	4750	4850	5900	5050	8500	7850	7950	9350	4700
Lincoln To Beatrice .....	1500	1750	1700	2650	1750	1950	2000	2400	2050	3450	3200	3250	3800	1900
Beatrice To Marysville .....	2250	2650	2550	4050	2700	2950	3000	3650	3150	5250	4900	4950	5800	2900
Julesburg To LaSalle .....	3650	4250	4100	6550	4350	4750	4850	5900	5050	8500	7850	7950	9350	4700
Cheyenne To Archer .....	2000	2350	2250	3600	2350	2600	2850	3250	2800	4650	4300	4350	5150	2550
Valley To Co. Bluffs .....	2600	3000	2950	4850	3100	3400	3450	4200	3000	6050	5600	5650	6650	3300
Marysville To Beatrice .....	3050	3500	3400	5450	3600	3950	4050	4900	4200	7050	6550	6600	7750	3900
Beatrice To Valparaiso .....	2600	3000	2950	4650	3100	3400	3450	4200	3600	6050	5600	5650	6650	3300
Valparaiso To Valley .....	1250	1450	1450	2250	1450	1650	1700	2050	1750	2950	2750	2750	3200	1600
Cheyenne To Buford .....	1000	1200	1150	1800	1200	1350	1350	1650	1400	2400	2200	2250	2600	1300
Cheyenne To Dale .....	1750	2050	2000	3150	2050	2300	2350	2850	2450	4100	3800	3850	4500	2250

Buford To Wahsatch .....	1750	2050	2000	3150	2050	2300	2350	2850	2450	4100	3800	3850	4500	2250
LaSalle To Carr .....	1500	1750	1700	2650	1750	1950	2000	2400	2050	3450	3200	3250	3800	1900
Carr To Borie .....	1250	1450	1450	2250	1450	1650	1700	2050	1750	2950	2750	2750	3200	1600
Ogden To Wahsatch on EB Track .	1300	1550	1500	2350	1550	1700	1750	2150	1850	3100	2850	2900	3350	1700
Ogden To Wahsatch on WB Track .	900	1050	1000	1600	1050	1200	1200	1450	1250	2100	1950	2000	2300	1150
Wahsatch To Laramie .....	1750	2050	2000	3150	2050	2300	2350	2850	2450	4100	3800	3850	4500	2250
Laramie To Sherman Via Forelle ...	1750	2050	2000	3150	2050	2300	2350	2850	2450	4100	3800	3850	4500	2250
Laramie To Sherman Via Red Buttes	900	1050	1000	1600	1050	1200	1200	1450	1250	2100	1950	2000	2300	1150
LaSalle To Denver Via Lupton ....	2600	3000	2950	4650	3100	3400	3450	4200	3600	6050	5600	5650	6650	3300
Kansas City To Salina .....	3650	4250	4100	6550	4350	4750	4850	5900	5050	8500	7850	7950	9350	4700
Salina To Ellsworth .....	1250	1450	1450	2250	1450	1650	1700	2050	1750	2950	2750	2750	3200	1600
Ellsworth To Ellis .....	1600	1900	1850	2900	1900	2100	2150	2650	2250	3800	3500	3550	4150	2100
Ellis To Denver .....	1500	1750	1700	2650	1750	1950	2000	2400	2050	3450	3200	3250	3800	1900
St. Joseph To Marysville .....	1300	1550	1500	2350	1550	1700	1750	2150	1800	3100	2850	2900	3350	1700
Menoken To Marysville .....	2250	2650	2550	4050	2700	2950	3000	3650	3150	5250	4900	4950	5800	2900
Marysville To Hastings .....	1750	2050	2000	3150	2050	2300	2350	2850	2450	4100	3800	3850	4500	2250
Hastings To Gibbon .....	2600	3000	2950	4650	3100	3400	3450	4200	3600	6050	5600	5650	6650	3300
Denver To Ellis .....	1500	1750	1700	2650	1750	1950	2000	2400	2050	3450	3200	3250	3800	1900
Ellis To Ellsworth .....	2600	3000	2950	4650	3100	3400	3450	4200	3600	6050	5600	5650	6650	3300
Ellsworth To Salina .....	1500	1750	1700	2650	1750	1950	2000	2400	2050	3450	3200	3250	3800	1900
Salina To Kansas City .....	3650	4250	4100	6550	4350	4750	4850	5900	5050	8500	7850	7950	9350	4700
Gibbon To Hastings .....	2600	3000	2950	4650	3100	3400	3450	4200	3600	6050	5600	5650	6650	3300
Hastings To Marysville .....	1750	2050	2000	3150	2050	2300	2350	2850	2450	4100	3800	3850	4500	2250
Marysville To Menoken .....	2250	2650	2550	4050	2700	2950	3000	3650	3150	5250	4900	4950	5800	2900
Marysville To St. Joseph .....	1100	1250	1250	1950	1250	1400	1450	1750	1500	2550	2350	2400	2800	1400

**TONNAGE RATINGS FOR ONE LOCOMOTIVE UNIT  
FOR FREIGHT TRAINS AVERAGING 50 GROSS TONS PER CAR  
RATINGS APPLY AT THE INDICATED MINIMUM CONTINUOUS SPEED**

UTAH DIVISION	100-129	131-349	305-347 470-499 2000 HP	400-448	450-459	700-739B 800-875	740-763	1400-1409	2000-2059	2810-2959 2400-2539	3000-3808 99 3000 HP	1-50 60-65 3600 HP	6900-6946	9000-9005
	1500 HP EMD GP7	1750 HP EMD GP9	EMD GP9M GP20	2400 HP EMD SD24	1500 HP EMD SD7	2250 HP EMD GP30	2500 HP EMD GP35	2500 HP EMD SDP35	2000 HP EMD GP38-2	3000 HP GE U30C C30-7	EMD SD40 SD40-2	EMD SD45	6600 HP EMD DD40X	3500 HP EMD GP40X
	12 MPH	12 MPH	14 MPH	10 MPH	6 MPH	12 MPH	12 MPH	12 MPH	11 MPH	10 MPH	11 MPH	11 MPH	11 MPH	11 MPH
McCammon To Ogden .....	2000	2350	2250	3600	2350	2600	2650	3250	2800	4650	4300	4350	5150	2550
Ogden To Salt Lake .....	2600	3000	2950	4650	3100	3400	3450	4200	3600	6050	5600	5650	6650	3300
Salt Lake To Lynndyl Via Warner .....	1750	2050	2000	3150	2050	2300	2350	2850	2450	4100	3800	3850	4500	2250
Salt Lake To Provo .....	1300	1550	1500	2350	1550	1700	1750	2150	1850	3100	2850	2900	3350	1700
Provo To Lynndyl .....	1500	1750	1700	2650	1750	1950	2000	2400	2050	3450	3200	3250	3800	1900
Lynndyl To Milford .....	2250	2650	2550	4050	2700	2950	3000	3650	3150	5250	4900	4950	5800	2900
Milford To Las Vegas .....	1500	1750	1700	2650	1750	1950	2000	2400	2050	3450	3200	3250	3800	1900
Las Vegas To Caliente .....	1000	1200	1150	1800	1200	1350	1350	1650	1400	2400	2200	2250	2600	1300
Caliente To Crestline .....	750	900	850	1350	850	1000	1050	1250	1050	1800	1650	1700	1950	1000
Crestline To Milford .....	3650	4250	4100	6550	4350	4750	4850	5900	5050	8500	7850	7950	9350	4700
Milford To Lynndyl .....	2250	2650	2550	4050	2700	2950	3000	3650	3150	5250	4900	4950	5800	2900
Lynndyl To Salt Lake Via Warner .....	1750	2050	2000	3150	2050	2300	2350	2850	2450	4100	3800	3850	4500	2250
Lynndyl To Provo .....	1500	1750	1700	2650	1750	1950	2000	2400	2050	3450	3200	3250	3800	1900
Provo To Salt Lake .....	1250	1450	1450	2250	1450	1650	1700	2050	1750	2950	2750	2750	3200	1600
Salt Lake To Ogden .....	2600	3000	2950	4650	3100	3400	3450	4200	3600	6050	5600	5650	6650	3300
Ogden To McCammon .....	2000	2350	2250	3600	2350	2600	2650	3250	2800	4650	4300	4350	5150	2550

**TONNAGE RATINGS FOR ONE LOCOMOTIVE UNIT  
FOR FREIGHT TRAINS AVERAGING 50 GROSS TONS PER CAR  
RATINGS APPLY AT THE INDICATED MINIMUM CONTINUOUS SPEED**

CALIFORNIA DIVISION	100-129	131-349	305-347 470-499 2000 HP	400-448	450-459	700-739B 800-875	740-763	1400-1409	2000-2059	2810-2959 2400-2539	3000-3808 99 3000 HP	1-50 60-65 3600 HP	6900-6946	9000-9005
	1500 HP EMD GP7	1750 HP EMD GP9	EMD GP9M GP20	2400 HP EMD SD24	1500 HP EMD SD7	2250 HP EMD GP30	2500 HP EMD GP35	2500 HP EMD SDP35	2000 HP EMD GP38-2	3000 HP GE U30C C30-7	EMD SD40 SD40-2	EMD SD45	6600 HP EMD DD40X	3500 HP EMD GP40X
	12 MPH	12 MPH	14 MPH	10 MPH	6 MPH	12 MPH	12 MPH	12 MPH	11 MPH	10 MPH	11 MPH	11 MPH	11 MPH	11 MPH
Las Vegas To Yermo .....	1500	1750	1700	2650	1750	1950	2000	2400	2050	3450	3200	3250	3800	1900
Yermo To Victorville .....	2000	2350	2250	3600	2350	2600	2650	3250	2800	4650	4300	4350	5150	2550
Victorville To Summit .....	950	1100	1100	1700	1100	1250	1300	1550	1350	2250	2100	2100	2450	1200
San Bernardino To Los Angeles .....	2250	2650	2550	4050	2700	2950	3000	3650	3150	5250	4900	4950	5800	2900
Los Angeles To San Bernardino .....	1500	1750	1700	2650	1750	1950	2000	2400	2050	3450	3200	3250	3800	1900
San Bernardino To Summit On North Track .....	700	800	800	1250	800	900	950	1100	950	1650	1500	1550	1750	850
San Bernardino To Summit On South Track .....	500	600	550	900	550	650	650	800	700	1200	1100	1100	1250	600
Summit To Kelso .....	1500	1750	1700	2650	1750	1950	2000	2400	2050	3450	3200	3250	3800	1900
Kelso To Cima .....	700	800	800	1250	800	900	950	1100	950	1650	1500	1550	1750	900
Cima To Las Vegas .....	1500	1750	1700	2650	1750	1950	2000	2400	2050	3450	3200	3250	3800	1900

**TONNAGE RATINGS FOR ONE LOCOMOTIVE UNIT  
FOR FREIGHT TRAINS AVERAGING 50 GROSS TONS PER CAR  
RATINGS APPLY AT THE INDICATED MINIMUM CONTINUOUS SPEED**

IDAHO DIVISION	100-129	131-349	305-347 470-499 2000 HP	400-448	450-459	700-739B 800-875	740-763	1400-1409	2000-2059	2810-2959 2400-2539	3000-3808 99 3000 HP	1-50 60-65 3600 HP	6900-6946	9000-9005
	1500 HP EMD GP7	1750 HP EMD GP9	EMD GP9M GP20	2400 HP EMD SD24	1500 HP EMD SD7	2250 HP EMD GP30	2500 HP EMD GP35	2500 HP EMD SDP35	2000 HP EMD GP38-2	GE U30C C30-7	EMD SD40 SD40-2	EMD SD45	6600 HP EMD DD40X	3500 HP EMD GP40X
	12 MPH	12 MPH	14 MPH	10 MPH	6 MPH	12 MPH	12 MPH	12 MPH	11 MPH	10 MPH	11 MPH	11 MPH	11 MPH	11 MPH
Granger To Montpelier .....	1750	2050	2000	3150	2050	2300	2350	2850	2450	4100	3800	3850	4500	2250
Montpelier To Pocatello .....	3050	3500	3400	5450	3600	3950	4050	4900	4200	7050	6550	6600	7750	3900
Pocatello To Glenns Ferry .....	2250	2650	2550	4050	2700	2950	3000	3650	3150	5250	4900	4950	5800	2900
Glenns Ferry To Reverse .....	1000	1200	1150	1800	1200	1350	1350	1650	1400	2400	2200	2250	2600	1300
Reverse To Nampa .....	3050	3500	3400	5450	3600	3950	4050	4900	4200	7050	6550	6600	7750	3900
Orchard To Nampa via Boise .....	3050	3500	3400	5450	3600	3950	4050	4900	4200	7050	6550	6600	7750	3900
Nampa To Huntington .....	3650	4250	4100	6550	4350	4750	4850	5900	5050	8500	7850	7950	9350	4700
Pocatello To Idaho Falls .....	3650	4250	4100	6550	4350	4750	4850	5900	5050	8500	7850	7950	9350	4700
Idaho Falls To Butte .....	600	750	700	1150	700	850	850	1000	900	1500	1400	1400	1600	800
Huntington To Boise .....	3650	4250	4100	6550	4350	4750	4850	5900	5050	8500	7850	7950	9350	4700
Boise To Orchard .....	1500	1750	1700	2650	1750	1950	2000	2400	2050	3450	3200	3250	3800	1900
Nampa To Glenns Ferry via Kuna .....	2600	3000	2950	4650	3100	3400	3450	4200	3600	6050	5600	5650	6650	3300
Glenns Ferry To Ticeska .....	1000	1200	1150	1800	1200	1350	1350	1650	1400	2400	2200	2250	2600	1300
Ticeska To Pocatello .....	2000	2350	2250	3600	2350	2600	2650	3250	2800	4650	4300	4350	5150	2550
Pocatello To Granger .....	1500	1750	1700	2650	1750	1950	2000	2400	2050	3450	3200	3250	3800	1900
Butte To Idaho Falls .....	750	900	850	1350	850	1000	1050	1250	1050	1800	1650	1700	1950	950
Idaho Falls To Pocatello .....	3650	4250	4100	6550	4350	4750	4850	5900	5050	8500	7850	7950	9350	4700

**TONNAGE RATINGS FOR ONE LOCOMOTIVE UNIT  
FOR FREIGHT TRAINS AVERAGING 50 GROSS TONS PER CAR  
RATINGS APPLY AT THE INDICATED MINIMUM CONTINUOUS SPEED**

OREGON DIVISION	100-129	131-349	305-347 470-499 2000 HP	400-448	450-459	700-739B 800-875	740-763	1400-1409	2000-2059	2810-2959 2400-2539	3000-3808 99 3000 HP	1-50 60-65 3600 HP	6900-6946	9000-9005
	1500 HP EMD GP7	1750 HP EMD GP9	EMD GP9M GP20	2400 HP EMD SD24	1500 HP EMD SD7	2250 HP EMD GP30	2500 HP EMD GP35	2500 HP EMD SDP35	2000 HP EMD GP38-2	GE U30C C30-7	EMD SD40 SD40-2	EMD SD45	6600 HP EMD DD40X	3500 HP EMD GP40X
	12 MPH	12 MPH	14 MPH	10 MPH	6 MPH	12 MPH	12 MPH	12 MPH	11 MPH	10 MPH	11 MPH	11 MPH	11 MPH	11 MPH
Huntington To Encina .....	700	800	800	1250	800	900	950	1100	950	1650	1500	1550	1750	850
Baker To LaGrande .....	1500	1750	1700	2650	1750	1950	2000	2400	2050	3450	3200	3250	3800	1900
LaGrande To Kamela .....	700	800	800	1250	800	900	950	1100	950	1650	1500	1550	1750	850
Kamela To Hinkle .....	3650	4250	4100	6550	4350	4750	4850	5900	5050	8500	7850	7950	9350	4700
Hinkle To Portland .....	2600	3000	2950	4650	3100	3400	3450	4200	3600	6050	5600	5650	6650	3300
Portland To Seattle .....	1600	1900	1850	2900	1900	2100	2150	2650	2250	3800	3500	3550	4150	2100
Hinkle To Spokane .....	2250	2650	2550	4050	2700	2950	3000	3650	3150	5250	4900	4950	5800	2900
Spokane To Sandpoint .....	2600	3000	2950	4650	3100	3400	3450	4200	3600	6050	5600	5650	6650	2300
Sandpoint To Eastport .....	1500	1750	1700	2650	1750	1950	2000	2400	2050	3450	3200	3250	3800	1900
Seattle To Portland .....	1300	1550	1500	2350	1550	1700	1750	2150	1850	3100	2850	2900	3350	1700
Portland To Hinkle .....	2250	2650	2550	4050	2700	2950	3000	3650	3150	5250	4900	4950	5800	2900
Hinkle To Kamela .....	700	800	800	1250	800	900	950	1100	950	1650	1500	1550	1750	850
LaGrande To Encina .....	1000	1200	1150	1800	1200	1350	1350	1650	1400	2400	2200	2250	2600	1300
Eastport To Sandpoint .....	1500	1750	1700	2650	1750	1950	2000	2400	2050	3450	3200	3250	3800	1900
Sandpoint To Spokane .....	2600	3000	2950	4650	3100	3400	3450	4200	3600	6050	5600	5650	6650	3300
Spokane To Hinkle .....	2250	2650	2550	4050	2700	2950	3000	3650	3150	5250	4900	4950	5800	2900

# CAR CHART

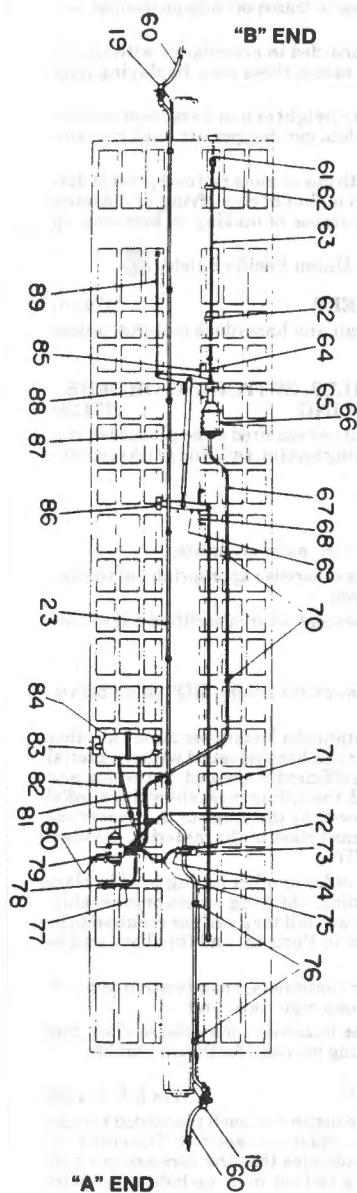
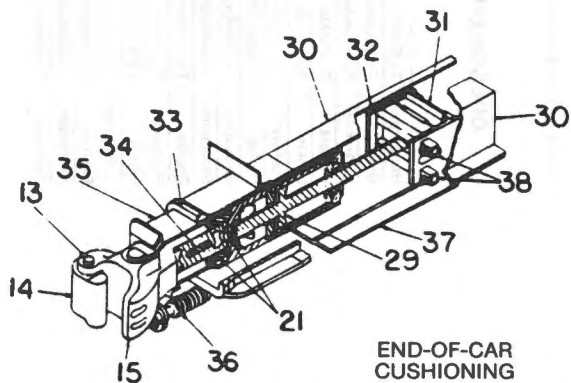
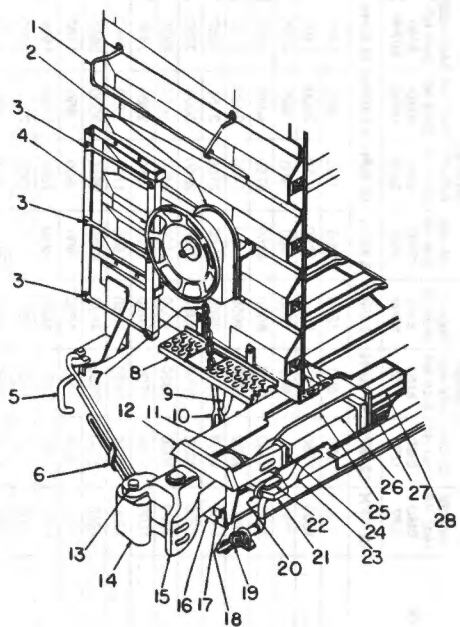
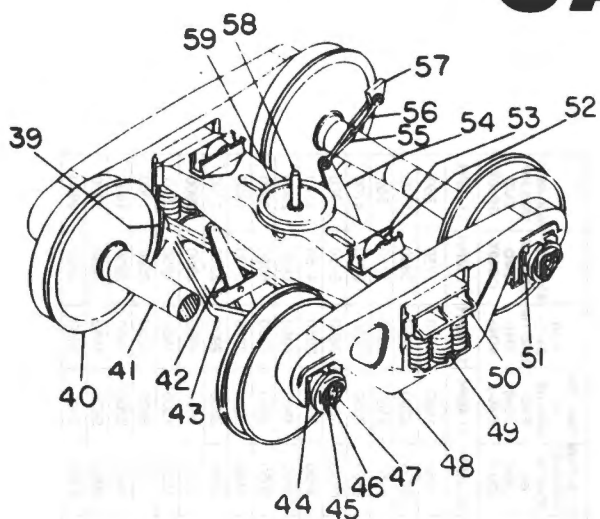

1. Horizontal end handhold
2. Hand brake housing
3. End ladder tread
4. Hand brake wheel
5. Telescoping uncoupling rod
6. Uncoupling lever guide
7. Hand brake chain
8. End platform (combined crossover and brake step)
9. Bell crank
10. Vertical hand brake rod
11. Front draft gear stop
12. Striker
13. Coupler knuckle pin
14. Coupler knuckle
15. Type E coupler head
16. Coupler carrier
17. Coupler wear plate
18. Striker flange
19. Angle cock
20. Draft key washer
21. Draft key
22. Draft key retainer
23. Brake pipe 1-1/4" (Train line)
24. Follower block
25. Coupler yoke
26. Draft gear
27. Rear draft gear stop
28. Rear draft gear stop reinforcement
29. Hydraulic piston
30. Center sill
31. Back stop plate
32. Rear lug casting
33. Striker casting
34. Coupler key
35. Cushioning unit
36. Restoring mechanism
37. Inspection plate
38. Rear cross key
39. Brake shoe
40. Wheel
41. Axle
42. Truck live lever
43. Brake beam
44. Roller bearing adapter
45. Roller bearing end cap
46. End cap retaining bolt
47. End cap locking plate
48. Truck side frame
49. Truck spring
50. Truck bolster
51. Roller bearing assembly
52. Truck side bearing roller
53. Truck side bearing housing
54. Truck dead lever
55. Clevis at dead lever
56. Clevis at dead lever fulcrum
57. Dead lever anchor—underframe mounted
58. Center pin
59. Truck center plate cast integral with truck bolster
60. Air hose
61. Hand brake chain at bell crank
62. Hand brake rod guide
63. Hand brake rod
64. Hand brake chain at cylinder
65. Cylinder push rod
66. Air brake cylinder
67. Cylinder pipe, 3/4"
68. Floating lever guide
69. Floating lever
70. Pipe clamp, 3/4"
71. Top rod "A" end
72. Branch pipe tee
73. Branch pipe tee support
74. Combined dirt collector and cut-out cock
75. Connection hose
76. Pipe clamp, 1-1/4"
77. Retainer pipe
78. Retainer valve
79. ABD control valve
80. Release rod
81. Auxiliary reservoir pipe, 3/4"
82. Emergency reservoir pipe, 3/4"
83. Reservoir support
84. Combined auxiliary and emergency reservoir
85. Cylinder lever guide
86. Brake lever fulcrum
87. Brake slack adjuster
88. Cylinder lever
89. Top rod "B" end

Reproduced with permission of  
 ©1970, The Railway Educational Bureau  
 1809 Capital Avenue, Omaha, Nebraska 68102  
 Simmons-Boardman Publishing Corporation

## APPENDIX 12 HANDLING HAZARDOUS MATERIALS

713 (R).

Referring to Rule 713 and Consolidated Code Rule 729, when switching or handling placarded cars containing hazardous materials, Bureau of Explosives Tariff BOE 6000C, publishing the Hazardous Materials Regulations of the Department of Transportation (DOT) must be complied with. Complete copy of this tariff is maintained at all agencies.

### DEFINITIONS (171.8)

For the purpose of DOT Regulations, the following Definitions apply:

"Engine" means locomotive propelled by any form of energy used by a railroad.

"Occupied caboose" means a rail car being used to transport non-passenger personnel.

"Placarded car" means a rail car which is placarded in accordance with the requirements of Part 172 of the DOT regulations, except those cars displaying only the FUMIGATION placards.

"Rail freight car" means a car designed to carry freight or non-passenger personnel by rail, and includes a box car, flat car, gondola car, hopper car, tank car, and occupied caboose.

"Train" means one or more engines coupled with one or more rail cars, except during switching operations or where the operation is that of classifying and assembling rail cars within a railroad yard for the purpose of making or breaking up trains.

Union Pacific Special Rules are indicated by Union Pacific Shield. 

### SHIPPING PAPERS (174.24)

No person may accept for transportation by rail any hazardous material unless he has received a shipping paper.

### INFORMATION REQUIRED ON WAYBILLS, SWITCHING ORDERS AND OTHER BILLING (174.25)

(a) When the initial movement of a loaded rail car required to be placarded is a switching operation, the switching order, switching receipt, switching ticket or other billing must contain the following:

- (1) The proper shipping name;
- (2) The hazard class;
- (3) Identification number preceded by UN or NA, as appropriate;
- (4) The total quantity (by weight, volume or as otherwise appropriate) of the hazardous material covered by the description;
- (5) The shipper's certification and signature, except when a certified bill of lading is tendered to the carrier;
- (6) The placard notation;
- (7) For any material that is a hazardous substance, the letters "RQ" either before or after the basic description.

(b) For empty tank cars which previously contained a hazardous material, other than a combustible liquid, or unless the tank car has been reloaded with a material not subject to these regulations, or has been sufficiently cleaned of residue and purged of vapor to remove any potential hazard, the billing must show the word(s) "EMPTY" or "EMPTY: Last Contained", followed by the name of the hazardous material last contained in the tank car, the hazard class of the material, the identification number and the word, "PLACARDED".

(c) Each waybill, switching ticket, switching order or other billing used in place thereof, prepared by the carrier from bills of lading, shipping orders or other shipping papers, and each shipping order used as a waybill for a rail car required to be placarded must contain the information shown in Parts (a) and (b) above and be plainly marked by the carrier with —

- (1) In the case of a flat car carrying trailers or containers, an indication of which trailers or containers contain the hazardous materials; and
- (2) The placard endorsement specified for the hazardous material or class concerned near the space on the face of the billing provided for the car number.

### INSPECTION (174.8 & 174.59)

(a) At any point where a train is required to be inspected, each placarded rail car and each rail car immediately adjacent thereto, must be inspected. The cars may continue in transit only when the inspection indicates that the cars are in a safe condition for transportation. The inspection of a rail car must include a visual inspection for obvious defects of the running gear, any leakage of contents from the car and to determine whether all required placards are in place and conform to the information given on the train consist or other shipping document.

(b) No person may transport a rail car carrying hazardous materials unless it is marked and placarded as required. Placards and car certificates lost in transit must be replaced at the next inspection point, and those not required must be removed at the next terminal where the train is classified.

### INSPECTION OF TANK CARS (174.9)

(a) Each loaded placarded tank car must be inspected by the carrier before acceptance at the originating point and when received in interchange to see that they are not leaking and that the air and handbrakes, journal boxes, and trucks are in proper condition for service.

(b) An empty tank car which previously contained a hazardous material and which is tendered for movement or received in interchange must have all manhole covers, outlet valve reducers, outlet valve caps, outlet valve cap plugs, end plugs, and plugs or caps or other openings securely in their proper places, except that heater coil inlet and outlet pipes must be left open for drainage.

### INSPECTION OF CARS AT INTERCHANGE (174.10)

(a) Each rail car containing explosives requiring "EXPLOSIVES A" placards which is offered by a connecting line must be visually inspected externally by the receiving line. If practicable, the receiving carrier should also inspect the lading. The car may not be forwarded until all discovered violations have been corrected.

(b) If the car shows evidence of or if there is any reason to suspect that it has received rough treatment, the lading must be inspected and placed in proper condition before the car is permitted to proceed. When interchange occurs and the inspection is performed after daylight hours, electric flashlights should be used and naked lights may not be used.

(c) A car containing packages of hazardous material other than explosives may not be offered in interchange if the packages are in a leaking condition.

(d) In the case of a tank car which has developed small leaks in the course of its movement to an interchange point and which requires a short movement to effect delivery for unloading by the consignee, the movement may be made if it can be made safely adhering to the precaution prescribed under the heading Leaking Tank Cars.

### LEAKING PACKAGES OTHER THAN TANK CARS (174.48)

Leaking packages other than tank cars may not be forwarded until repaired or reconditioned.

### LEAKING TANK CARS (174.50)

(a) A tank car discovered in a leaking condition in transit may not be unnecessarily moved until the unsafe condition has been corrected. In the case of a small leak, short movements may be made if a receptacle is attached under the leak to prevent the spread of the liquid over tracks.

(b) Each leaking tank car must be protected against ignition of the liquid or vapor by flame from sources such as lanterns, torches, flares, fuses, switchlights, switch-thawing flames, fires on sides of tracks, hot coals, lighted pipes, cigars, or cigarettes. All spectators should be kept at a safe distance.

(c) A leaking tank car containing any hazardous material may be switched to a location distant from habitation and highways if the move can be safely made.

### CANADIAN SHIPMENTS AND PACKAGES (174.11)

A Canadian shipment or package may be transported by rail car within the United States if it is in compliance with these regulations or the regulations of the Canadian Transport Commission.

### SWITCHING OF CARS CONTAINING HAZARDOUS MATERIALS, PLACARDED FLAT CARS, OR FLAT CARS CARRYING PLACARDED TRAILERS, FREIGHT CONTAINERS, PORTABLE TANKS OR IM PORTABLE TANKS (174.83 & 174.84)

(a) The following cars must not be cut off while in motion, must not be humped or kicked or coupled into with more force than is necessary to complete the coupling. Also, no car or cars moving under their own momentum shall be allowed to strike any of the following placarded cars:

- (1) Any car placarded "EXPLOSIVES A".
- (2) Any car placarded "POISON GAS".
- (3) A placarded flat car, or any flat car carrying placarded trailers or freight containers, portable tanks or IM portable tanks.
- (4) Loaded tank cars placarded "FLAMMABLE GAS".
- (5) Loaded tank cars placarded "CHLORINE".
- (6) Loaded tank cars phosphorus placarded "FLAMMABLE SOLID".
- (7) Tank cars last containing phosphorus filled with waste water placarded "EMPTY FLAMMABLE SOLID".
- (8) Any car placarded "RADIOACTIVE MATERIAL."

(b) When transporting a car placarded "EXPLOSIVES A", in a terminal, yard, or on a side track, or siding, it must be separated from the engine by at least one non-placarded car.

(c) The doors of each closed car placarded "EXPLOSIVES A" must be closed, securely fastened, and the lading securely braced before it is moved.

(d) In switching operations where the use of hand brakes is necessary, a loaded placarded tank car, or a cut of cars which includes a loaded placarded tank car, must not be cut off until the preceding car or cars have cleared the track. The cut of cars containing the loaded placarded tank car must clear the lead track before another car is allowed to follow. In switching operations where hand brakes are used, it must be determined by trial whether a loaded placarded car or a car occupied by a rider in a cut of cars containing a placarded car, has its hand brakes in proper working condition before it is cut off.

### PLACEMENT OF FREIGHT CARS PLACARDED "EXPLOSIVES A" IN YARDS, ON SIDINGS OR SIDE TRACKS (174.85)

A rail car placarded "EXPLOSIVES A" while in a yard or on a siding or side track must be placed so that it will be safe from all probable danger of fire. A car so placarded may not be placed under a bridge or overhead highway crossing, not in or alongside a passenger shed or station except for loading or unloading purposes.

**POSITION IN TRAIN OF CARS PLACARDED "EXPLOSIVES A" OR "POISON GAS" WHEN ACCOMPANIED BY CARS CARRYING GUARDS OR TECHNICAL ESCORTS** (174.86)

A rail car placarded "EXPLOSIVES A" or "POISON GAS" in a moving or standing train must be next to and ahead of any car occupied by the guards or technical escorts accompanying this car. However, if a car occupied by guards or technical escorts is equipped with a lighted heater or stove, it must be the fourth car behind any car requiring "EXPLOSIVES A" placards.

**POSITION IN TRAIN OF CARS PLACARDED "EXPLOSIVES A"** (174.88)

In a moving or standing train, a car placarded "EXPLOSIVES A" may not be placed nearer than the sixth car from the engine or an occupied caboose. However, when the length of the train will not permit this car to be so placed, it must be placed as near the middle of the train as possible, but not less than the second car from the engine or occupied caboose.

**SEPARATING CARS PLACARDED "EXPLOSIVES A" OR "POISON GAS" FROM OTHER CARS IN TRAINS** (174.90)

(a) In a moving or standing train, a car placarded "EXPLOSIVES A" or "POISON GAS" may not be placed next to:

- (1) A passenger car or combination car that may be occupied except a car occupied by technical escorts and authorized personnel accompanying shipments;
- (2) Any loaded placarded car other than a car placarded with the same placard or one placarded "COMBUSTIBLE";
- (3) An engine;
- (4) A wooden underframe car (except on narrow gauge railroads);
- (5) A loaded flat car, except that loaded cars placarded "EXPLOSIVES A" may be placed next to each other. A flat car equipped with permanently attached ends of rigid construction is considered to be an open-top car. (See subparagraph (6) of this paragraph.)
- (6) An open-top car when any of the lading protrudes beyond the car ends or when any of the lading extending above the car ends is liable to shift so as to protrude beyond the car ends;
- (7) A car with automatic refrigeration or heating apparatus in operation, or a car with open-flame apparatus in service, or with an internal combustion engine in operation;
- (8) A car containing lighted heaters, stoves, or lanterns;
- (9) A car occupied by any person, including any attendant for the cargo contained therein, except as provided in Sec. 174.86; or
- (10) An occupied caboose, except as provided in Sec. 174.86.

(b) In a moving or standing train, a car placarded "EXPLOSIVES A" may not be placed next to a car placarded "POISON GAS".

**POSITION IN TRAIN OF CARS PLACARDED "RADIOACTIVE"** (174.89)

In a moving or standing train, a car placarded "RADIOACTIVE" may not be placed next to any other loaded placarded car (other than one placarded "COMBUSTIBLE"), an engine, occupied caboose, or carload of undeveloped film. Cars placarded "RADIOACTIVE" may be placed next to each other.

**POSITION IN TRAIN OF LOADED PLACARDED TANK CAR OTHER THAN CAR PLACARDED "COMBUSTIBLE"** (174.91)

Except for a tank car placarded "COMBUSTIBLE", a loaded placarded tank car in a moving or standing train may not be nearer than the sixth car from the engine, occupied caboose, or passenger car. However, when the length of the train will not permit a loaded placarded tank car to be so placed, it must be placed as near the middle of the train as possible and not nearer than the second car from the engine, occupied caboose, or passenger car.

**SEPARATING LOADED PLACARDED TANK CARS OTHER THAN TANK CARS PLACARDED "COMBUSTIBLE" FROM OTHER CARS IN TRAINS** (174.92)

(a) In a moving or standing train, a loaded placarded tank car, other than one placarded "COMBUSTIBLE", may not be placed next to:

- (1) A passenger car or combination car, other than a car occupied by technical escorts and authorized personnel accompanying shipments;
- (2) Any car placarded "EXPLOSIVES A", "RADIOACTIVE", or "POISON GAS";
- (3) An engine or occupied caboose;
- (4) A wooden underframe car (except on narrow gauge railroads);
- (5) A loaded flat car, other than a specially equipped car in trailer-on-flatcar, or container-on-flatcar service or a flatcar loaded with vehicles secured by means of a device designed for that purpose and permanently installed on the flatcar, and of a type generally accepted for handling in interchange between railroads subject to the following:
  - (i) A flat car equipped with permanently attached ends of rigid construction is considered to be an open-top car (see paragraph (a)(6) of this section); and

(ii) This exception for cars in trailer-on-flatcar service does not apply to loaded flatbed trucks, loaded flatbed trailers, loaded open-top trailers, or loaded trucks or trailers without securely closed doors;

- (6) An open-top car when any of the lading protrudes beyond the car ends or when any of the lading extending above the car ends is liable to shift so as to protrude beyond the car ends;
- (7) A car with automatic refrigeration or heating apparatus in operation or a car with open-flame apparatus in service or with an internal combustion engine in operation;
- (8) A car occupied by any person, including any attendant for the cargo contained therein.

**POSITION IN TRAIN OF EMPTY PLACARDED TANK CARS** (174.93)

In a moving or standing train, empty placarded tank cars, except empty tank cars last containing combustible liquid, may not be placed nearer than the second car from the engine or occupied caboose.

**NOTICE TO TRAIN CREWS OF PLACARDED CARS** (174.26)

(a) A member of the train crew of a train transporting hazardous materials must have in his possession a copy of the shipping papers for the shipment of hazardous materials being transported showing the information required by these regulations.

(b) The train crew must have a document indicating the position in the train of each loaded placarded car containing hazardous materials, except when the position is changed or the placarded car is placed in the train by a member of the train crew. A train consist may be used to meet this requirement.

(c) At each terminal or other place where trains are made up or switched by crews other than train crews accompanying the outbound movement of cars, the carrier shall execute consecutively numbered notices showing the location in each train of each rail car placarded "EXPLOSIVES A" or "POISON GAS". A copy of each notice must be delivered to the train and engine crew concerned, and a copy thereof showing delivery to the train and engine crew must be kept on file by the carrier at each point where the notice is given. At points where train or engine crews are changed, the notice must be transferred from crew to crew.

**HAZARDOUS MATERIALS INCIDENT HANDLING AND REPORTING**



**716 (R-1).** Whenever there is a derailment or fire involving or affecting hazardous materials, the conductor must notify dispatcher's office by the quickest means of communication advising:

- (a) The nature and circumstances of the incident;
- (b) Car number, commodity, location in train and the manner in which the car or cars containing the hazardous materials is involved or affected; and
- (c) Whether emergency services should be requested.

**APPENDIX 13  
REFERENCE GUIDE FOR SWITCHING PLACARDED CARS**

-342-



Any Car



Any Car



Placarded flat car or flat car carrying placarded trailers, freight containers, portable tanks, or IM portable tanks.



Any Car



Tank Car

I.D. No. \*

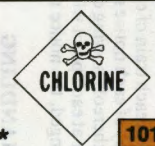

Tank Car

1017 \*



Loaded tank cars of phosphorus placarded "FLAMMABLE SOLID"

1381 \*



Tank cars last containing phosphorus filled with waste water placarded "EMPTY FLAMMABLE SOLID"

1381 \*

Must not be "HUMPED" or "KICKED"  
Must not be cut off in motion  
Must not be struck by any car moving under its own momentum  
Must not be coupled to with any more force than is necessary to make coupling

\*I.D. Nos. See Appendix 13A for examples of alternate Placards with identification numbers which may be used in lieu of above.



Any Car

**ADDITIONAL REQUIREMENTS FOR ANY CAR PLACARDED "EXPLOSIVES A"**

Must be separated from engine by at least one non-placarded car  
Must have doors closed before moving  
Must not be placed or left where there is any possible danger of fire  
Must not be placed or left under bridges, under overhead highway crossings or along passenger stations

-343-

**OTHER CARS DISPLAYING ANY OF THE FOLLOWING PLACARDS OR ALTERNATE PLACARDS**



**IN SWITCHING OPERATIONS WHERE USE OF HAND BRAKES IS NECESSARY:**

It must be determined by trial whether a loaded placarded car or a car occupied by a rider in a cut of cars containing a placarded car, has its hand brakes in proper working condition before it is cut off.

A loaded placarded tank car, or cut containing a loaded placarded tank car, must not be cut off until preceding cars are clear of the lead.

A loaded placarded tank car, or a cut containing a loaded placarded tank car, must be clear of lead before releasing any cars to follow.



The above restrictions do not apply to cars placarded "COMBUSTIBLE".

**EXAMPLES OF EMPTY PLACARDS**



There are no switching restrictions for empty tank cars which last contained a commodity whose residue could be harmful, except tank cars last containing phosphorus placarded "EMPTY FLAMMABLE SOLID".

**APPENDIX 13 A  
EXAMPLES  
OF ALTERNATE PLACARDS  
DISPLAYING THE IDENTIFICATION NUMBER.**

DOT requires that the four-digit identification number be displayed on tank car, portable tank and cargo tank shipments of hazardous materials in one of two ways: on orange panels, or on the "alternate" placard.

Cars displaying the alternate placard must be handled in the same manner as cars displaying the specified placard with the hazard class description.

Identification numbers may not be displayed on alternate placards for shipments "EXPLOSIVES", "POISON GAS", or "RADIOACTIVE". The specified hazard class placard always must be displayed.

In addition to the identification numbers being displayed, the United Nations hazard class number for the material being shipped must also be displayed in the lower corner of the placard. The United Nations hazard class numbering system (the IMCO system) ranges from Class 1 to Class 9, as indicated below:

Number	Name
1	Explosives
2	Gases
3	Flammable liquids
4	Flammable solids or substances
5	Oxidizing substances
6	Poisonous and infectious substances
7	Radioactive substances
8	Corrosives
9	Miscellaneous dangerous substances (Other regulated material)

**Compressed Gases:**

**NON FLAMMABLE GAS**

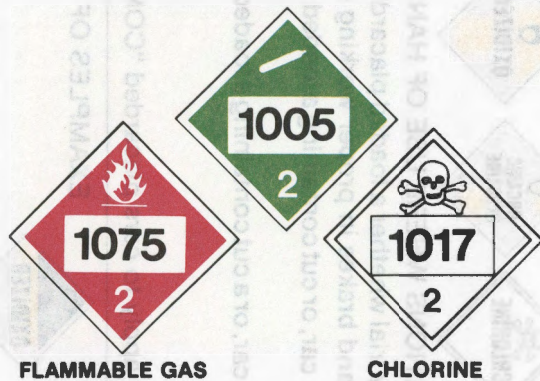

**Flammable and Combustible Liquids:**



**Flammable Solids:**



**Oxidizers:**



**Poisons:**

**Corrosives**

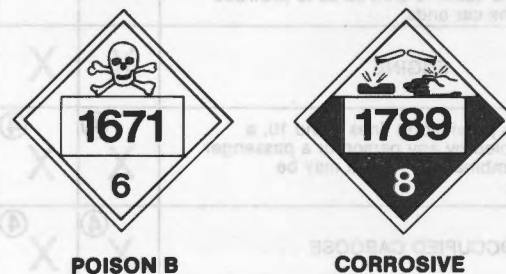

**Hazardous Substances:**



**OTHER REGULATED MATERIALS (ORM)**

**Example of alternate placard for empty tank car last containing a hazardous material:**



**APPENDIX 14 — POSITION IN TRAIN OF PLACARDED**

1	PLACARD APPLIED ON CAR	EXPLOSIVES A	POISON GAS
2	TYPE OF CAR	ANY CAR (inc. flat cars carrying trailers or containers)	TANK CAR OTHER THAN TANK CAR

**RESTRICTIONS**

3	When Train Length Permits	Must not be nearer than 6th car from engine, occupied caboose or passenger car	X <sup>①</sup>	X		
4	When Train Length Does Not Permit	Must be near middle of train but not nearer than 2nd car from engine or occupied caboose.	X	X		
<b>MUST NOT BE PLACED NEXT TO</b>						
5		Loaded flat car. A flat car equipped with permanently attached ends of rigid construction is considered to be an open-top car.	X <sup>②</sup>	X	X	
6		An open-top car when any of the lading protrudes beyond the car ends or when any of the lading extending above the car ends is liable to shift so as to protrude beyond the car ends.	X	X	X	
7		ENGINE	X	X	X	X
8		Except as provided in lines 9 and 10, a car occupied by any person or a passenger car or combination car that may be occupied.	X <sup>④</sup>	X <sup>④</sup>	X <sup>④</sup>	X
9		OCCUPIED CABOOSE	X <sup>④</sup>	X <sup>④</sup>	X <sup>④</sup>	X
10		OCCUPIED GUARD CAR	X <sup>④</sup>	X <sup>④</sup>	X <sup>④</sup>	
11		UNDEVELOPED FILM				X
12		A car with automatic refrigeration or heating apparatus in operation, or a car with open-flame apparatus in service, or with an internal combustion engine in operation.	X	X	X	
13		A car containing lighted heaters, stoves, or lanterns.	X	X	X	
14		EXPLOSIVES A		X	X	X
15		POISON GAS	X			X
16		Loaded placarded car, other than a car placarded with the same placard or the "COMBUSTIBLE" placard.	X	X	X	X
17		RADIOACTIVE	X	X	X	

**CARS CONTAINING HAZARDOUS MATERIALS**

POISON GAS	RADIOACTIVE	Any Placarded Load Other Than "COMBUSTIBLE" or "GAS"	Other Than Placarded "EXPLOSIVES A", "POISON GAS" or "COMBUSTIBLE"	PLACARDED EMPTY EXCEPT COMBUSTIBLE	COMBUSTIBLE
ANY CAR	TANK CAR	OTHER THAN TANK CAR	TANK CAR	TANK CAR	

**FOOTNOTES:**
**HOW TO USE THIS CHART:**

To determine where a placarded car can be placed in a train follow these steps.

- Determine type of placard applied to car.
- Determine type of car to which placard is applied.
- Read across to determine correct placement.
- See footnotes for explanation.

① A car placarded "EXPLOSIVES A" must be separated from engine, occupied caboose or passenger car with not less than two non-placarded 4-Runner cars (Series 60000-60100) or three nonplacarded cars and one non-placarded 4-Runner car.

With the exception of 4-Runner (Series 60000-60100), the balance of Line 3 remains the same.

② Loaded cars placarded "EXPLOSIVES A" may be placed next to each other.

③ A specially equipped car in trailer-on-flatcar or container-on-flatcar service or a flatcar loaded with vehicles secured by means of a device designed for that purpose and permanently installed on the flatcar, and of a type generally accepted for handling in interchange between railroads may be placed next to these placarded loaded tank cars subject to the following: this exception for cars in trailer-on-flatcar service does not apply to loaded flatbed trucks, loaded flatbed trailers, loaded open-top trailers, or loaded trucks or trailers without securely closed doors.

④ A rail car placarded "EXPLOSIVES A" or "POISON GAS" in a moving or standing train must be next to and ahead of any car occupied by the guards or technical escorts accompanying this car. However if a car occupied by guards or technical escorts is equipped with a lighted heater or stove, it must be the fourth car behind any car requiring "EXPLOSIVES A" placards.

⑤ Applies only in mixed train service.



Notes

Notes

Notes

Notes

Notes

