

DENVER & RIO GRANDE WESTERN R.R.
INSULATED BOX CARS No's. 60000 to 60076 EXCEPT 60037, 60047, 60052, 60064

F-1

AAR MECHANICAL DESIGNATION - X1

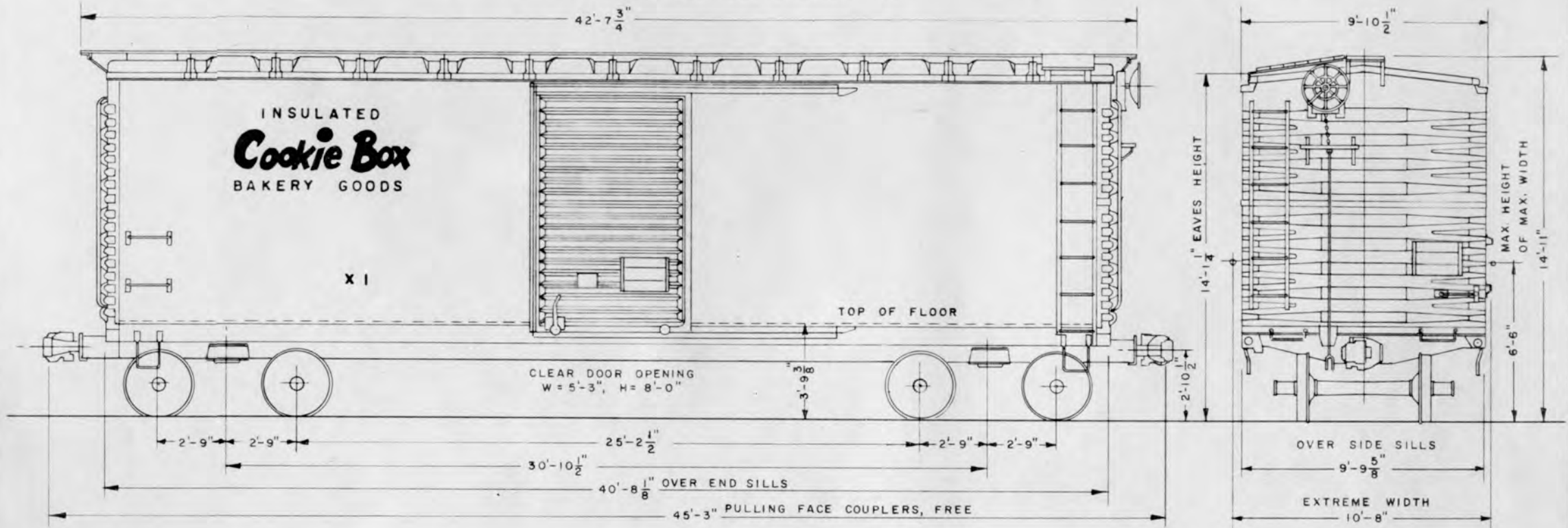

DESCRIPTION

GAUGE ----- 4'-8 1/2"	ROOF ----- MURPHY IMPROVED-SOLID STEEL	MARKED CAPACITY, LBS. ----- 110,000	
JOURNALS ----- 5 1/2" X 10"	ENDS ----- DREADNAUGHT 2-PIECE	LIGHT WEIGHT, LBS., AV. ----- 50,300	
60001, 60002, 60004, 60005, 60006, 60008, 60009, 60010, 60012, 60013, 60017, 60018, 60019, 60022-60027, 60030, 60031, 60032, 60034, 60035, 60036, 60048, 60049, 60050, 60053, 60055, 60057, 60058, 60059, 60061, 60063, 60073, 60076.	SIDES ----- HIGH TENSILE STEEL	MAX. WEIGHT OF LADING, LBS., AV. ----- 126,700	
WHEELS ----- ORIGINALLY 33" CAST IRON	LINING ----- PLYWOOD	CUBICAL CAPACITY, CU. FT. ----- 2906	
WHEELS - ALL OTHERS ----- 33" WROT STEEL I-W	FLOOR ----- PLASTINAIL	LENGTH INSIDE ----- 40'-0"	
60000-60036, 60048, 60049, 60050, 60053, 60055, 60057-60061, 60063, 60066, 60071, 60072, 60073.	INSULATION ----- GUSTIN-BACON-ULTRALITE	WIDTH INSIDE ----- 9'-1"	
TRUCK TYPE ----- TRUCK ASSOCIATION-RADIAL-SPRING PLANKLESS	UNDERFRAME ----- DURYEA	HEIGHT INSIDE ----- 8'-0"	
60038, 60039, 60042, 60044, 60045, 60056, 60062, 60065, 60067, 60068, 60069, 60070, 60074, 60075.	DOORS (EXCEPT 60040) ----- YOUNGSTOWN	LADING COMPLEMENT	
TRUCK TYPE ----- TRUCK ASSOCIATION-FLAT COLUMN-SPRING PLANK	DOORS (60040) ----- SUPERIOR	LADING RESTRAINING BARS ----- 12	
60040, 60041, 60043, 60046, 60051, 60054.	DOOR FIXTURES (EXCEPT 60040) ----- CAMEL ROLLER LIFT	PALLETS ----- 24	
TRUCK TYPE ----- BARBER STABILIZED-SPRING PLANK	DOOR FIXTURES (60040) ----- SUPERIOR	YEAR BUILT (AS 68000-69899 SERIES BOX CARS) ----- 1940, 41, 42	
TRUCK SIDES (ALL) ----- CAST STEEL-INTEGRAL BOXES	DRAFT GEAR ----- DURYEA	INSULATION APPLIED (60000-60036) ----- 1954, 1955	
TRUCK BOLSTER (ALL) ----- CAST STEEL	COUPLER ----- AAR TYPE E	INSULATION APPLIED (60038-60046) ----- 1959	
60040, 60041, 60043, 60046, 60051, 60054	BRAKE ----- AB 1012	INSULATION APPLIED (60048-60076) ----- 1961	
SIDE BEARINGS ----- BARBER MONOCAST	HAND BRAKE ----- AJAX	BUILDERS ----- PRESSED STEEL CAR CO.	
SIDE BEARINGS - REST HAVE ----- STUCK!	BRAKE SLACK ADJUSTER ----- ROYAL TYPE F		
	60000-60036, 60061, 60063, 60066, 60071, 60072, 60073, 60076		
	RUNNING BOARDS ----- WOOD		
	60038, 60039, 60042, 60044, 60048, 60049, 60050, 60053, 60055, 60057-60060, 60062, 60065, 60067-60070, 60074, 60075.		
	RUNNING BOARDS (60051) ----- U.S. GYPSUM CO.-STEEL		
	RUNNING BOARDS (60054) ----- BLAW-KNOX-STEEL		

DENVER & RIO GRANDE WESTERN R.R.

INSULATED BOX CAR No. 60080

AAR MECHANICAL DESIGNATION = RB

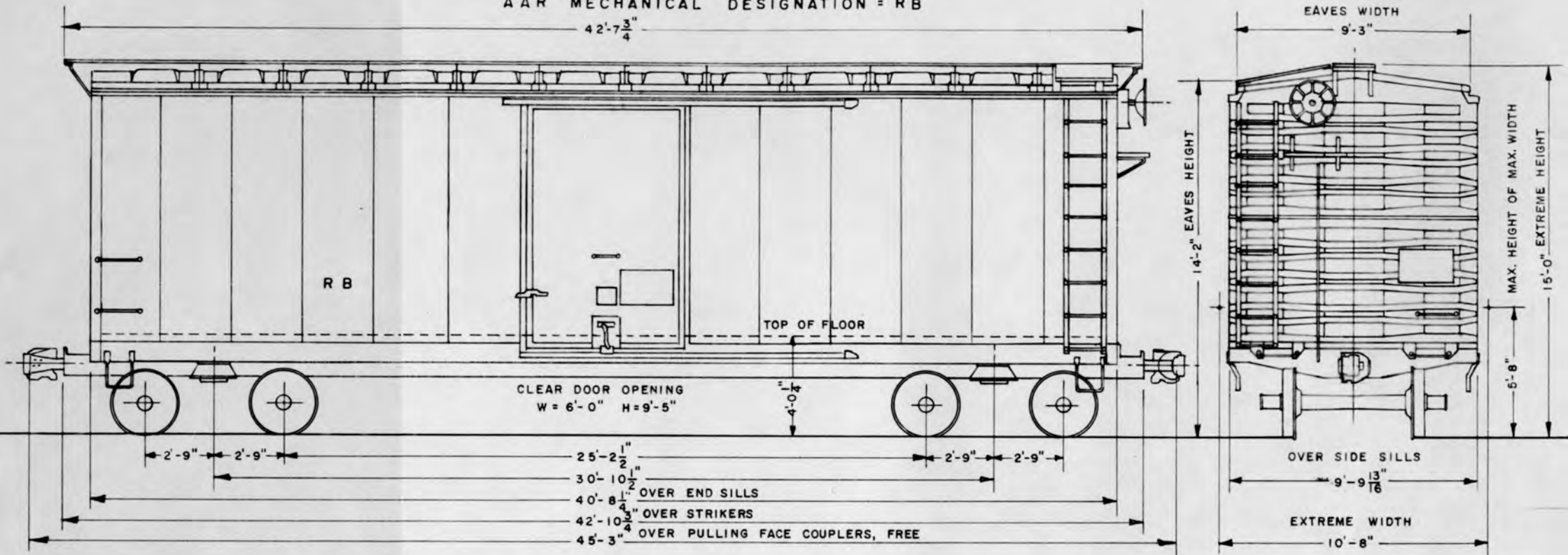

DESCRIPTION

GAUGE	4'-8 1/2"
JOURNALS	5 1/2" X 10"
WHEELS	33" WROT STEEL 1-W
TRUCK TYPE	ASF A-3 RIDE CONTROL
TRUCK SIDES	CAST STEEL-INTGRAIL BOXES
SPRING TRAVEL	3 1/16"
SIDE BEARINGS	STUCKI

ROOF	MURPHY IMPROVED-SOLID STEEL
ENDS	IMPROVED DREADNAUGHT 2-PIECE
SIDES	HIGH TENSILE STEEL
LINING	WOOD
INSULATION	URETHANE FOAM
FLOOR	DOWELOC-WOOD
UNDERFRAME	DURYEA
DOORS (INSULATED)	SUPERIOR
DOOR FIXTURES	SUPERIOR

DRAFT GEAR	DURYEA
COUPLER	AAR TYPE E
BRAKE	AB 1012
HAND BRAKE	UNIVERSAL
BRAKE SLACK ADJUSTER	ROYAL TYPE F
RUNNING BOARDS	STEEL-U.S. GYPSUM CO.

MARKED CAPACITY, LBS.	110,000
LIGHT WEIGHT, LBS.	47,800
MAXIMUM WEIGHT OF LADING, LBS.	129,200
CUBICAL CAPACITY, CU. FT.	3537
LENGTH INSIDE	40'-5 1/4"
WIDTH INSIDE	9'-2 1/4"
HEIGHT INSIDE	9'-6 1/4"

YEAR BUILT-AS BOX CAR NO. 67988 _____ 1946
 BUILDER _____ PRESSED STEEL CAR CO.
 INSULATION APPLIED _____ 1965

DENVER & RIO GRANDE WESTERN R.R.

F-5

SL BOX CARS No's. 60203, 60204, 60205

AAR MECHANICAL DESIGNATION = XML

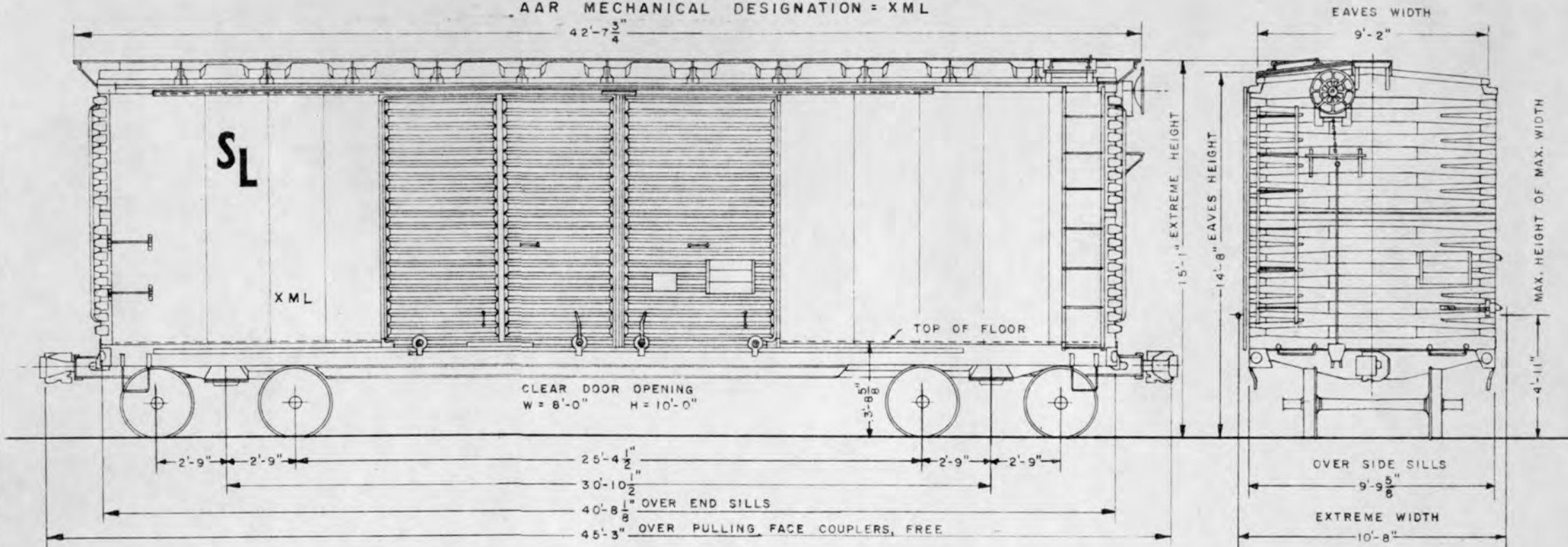

DESCRIPTION

GAUGE	4'-8 ¹ / ₂ "
JOURNALS	5 ¹ / ₂ " X 10"
WHEELS	33" WROT STEEL 1-W
TRUCK TYPE	TRUCK ASSN.-RADIAL-SPRING PLANKLESS
TRUCK SIDES	CAST STEEL-INTEGRAL BOXES
TRUCK BOLSTER	CAST STEEL
SIDE BEARINGS	STUCKI
HANGER TYPE BRAKE BEAMS	DAVIS OR CRECO
	NO. 15

— TRANSCO "SL" LOADER COMPLEMENT —

BELT RAILS	15
CROSSMEMBERS (ALUMINUM)	26
DOORWAY MEMBERS	10
SWINGBOARDS -8" (OFFSET 2 ¹ / ₂ " X 5 ¹ / ₂ ")	10
DECKBOARDS (48" X 105")	10

ROOF	MURPHY IMPROVED-SOLID STEEL
ENDS	DREADNAUGHT 2-PIECE
SIDES	STEEL
UNDERFRAME	DURYEA-STEEL
FLOOR	WOOD
DOORS	YOUNGSTOWN-STEEL
DOOR FIXTURES	CAMEL ROLLER LIFT
INSIDE DOORS	CORRUGATED STEEL-PLYWOOD LINED
DRAFT GEAR	DURYEA
COUPLER	AAR TYPE E
BRAKE	AB
HAND BRAKE	AJAX
BRAKE GEAR REGULATOR	ROYAL TYPE F

RUNNING BOARDS	APEX-STEEL
----------------	------------

MARKED CAPACITY, LBS.	110,000
LIGHT WEIGHT, LBS., AV.	51,900
MAX. WEIGHT OF LADING, LBS., AV.	117,100
CUBICAL CAPACITY, CU. FT.	3910
LENGTH INSIDE	40'-6"
WIDTH INSIDE	9'-0 ¹ / ₂ "
HEIGHT INSIDE, AT EAVES	10'-8"
HEIGHT INSIDE, AT CENTER	11'-1"

60203	FORMERLY	65145
60204	"	65112
60205		65131

YEAR BUILT - AS XM BOX CARS	1939
BUILDERS	PRESSED STEEL CAR CO.
SL LOADERS APPLIED	1964

DF BOX CAR No. 60206

AAR MECHANICAL DESIGNATION = XML

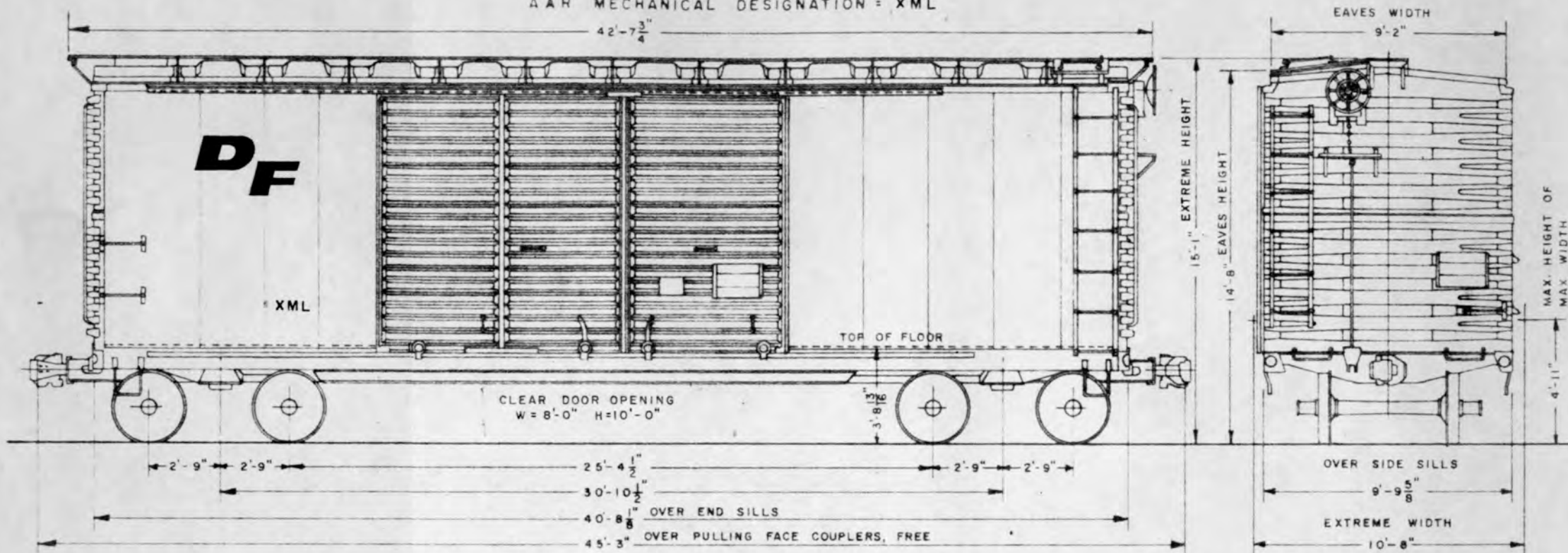

DESCRIPTION

GAUGE	4'-8 ¹ / ₂ "
JOURNALS	5 ¹ / ₂ " x 10"
WHEELS	33" WROT STEEL 1-W
TRUCK TYPE	TRUCK ASS'N.-RADIAL-SPRING PLANKLESS
TRUCK SIDES	CAST STEEL- INTEGRAL BOXES
TRUCK BOLSTER	CAST STEEL
SIDE BEARINGS	STUCKI

— DF-2 LOADER COMPLEMENT —

BELT RAILS	9
CROSSMEMBERS (ALUMINUM)	20
DOORWAY MEMBERS	8
SWINGBOARDS-8" (OFFSET 2 ¹ / ₂ " X 5 ¹ / ₂ ")	10
DECK BOARDS-INTERLOCKING (24" X 105")	10
DECK BOARDS-INTERLOCKING (48" X 105")	10

ROOF	MURPHY IMPROVED-SOLID STEEL
ENDS	DREADNAUGHT 2-PIECE
SIDES	STEEL
UNDERFRAME	DURVEA-STEEL
FLOOR	WOOD AND 3 ³ / ₁₆ " STEEL PLATE
DOORS	YOUNGSTOWN-STEEL
DOOR FIXTURES	CAMEL ROLLER LIFT

DRAFT GEAR	DURVEA
COUPLER	TYPE E
BRAKE	AB
HAND BRAKE	AJAX
BRAKE SLACK ADJUSTER	ROYAL TYPE F
RUNNING BOARDS	APEX-STEEL

MARKED CAPACITY, LBS.	110,000
LIGHT WEIGHT, LBS.	51,000
MAX. WEIGHT OF LADING, LBS.	126,000
CUBICAL CAPACITY, CU. FT.	3961

LENGTH INSIDE	40'-6"
WIDTH INSIDE	9'-2"
HEIGHT INSIDE, AT EAVES	10'-8"
HEIGHT INSIDE, AT CENTER	11'-1"

YEAR BUILT-AS XM BOX CAR NO. 65188	1939
BUILDERS	PRESSED STEEL CAR CO.
DF-2 LOADERS APPLIED	1964

DENVER & RIO GRANDE WESTERN R.R.

DF BOX CARS No's. 60207, 60209

F-7

AAR MECHANICAL DESIGNATION = XML

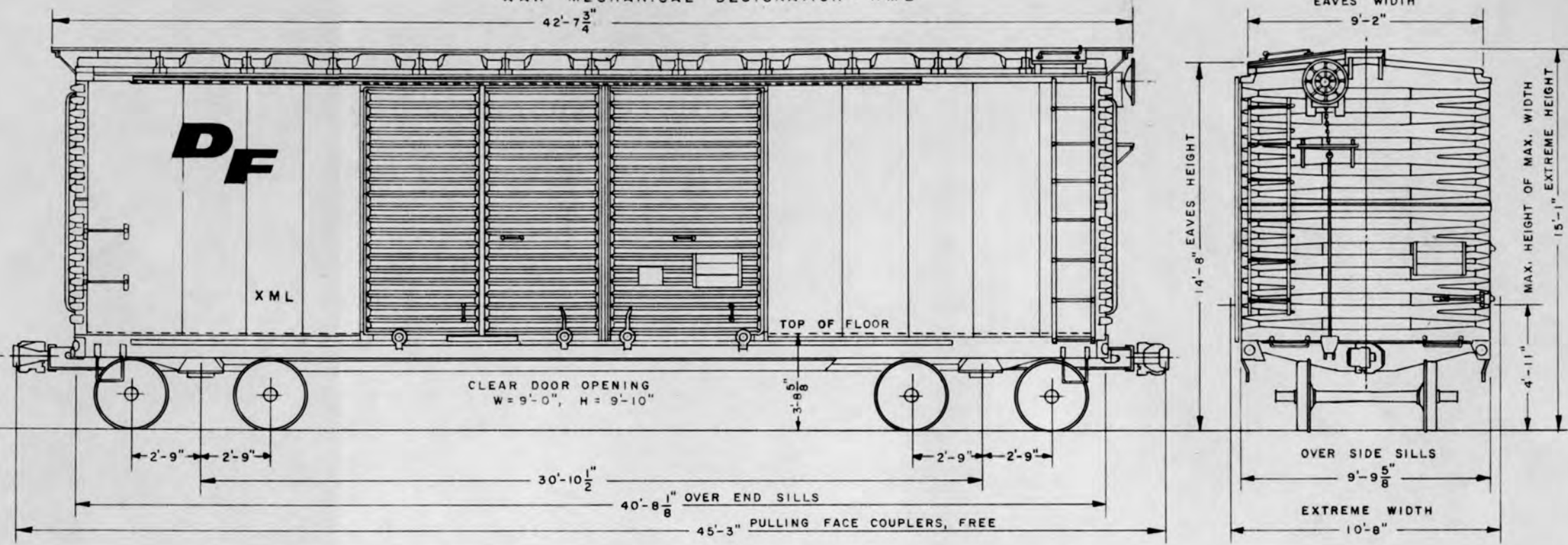

DESCRIPTION

GAUGE ----- 4'-8 1/2"
 JOURNALS ----- 5 1/2" X 10"
 WHEELS ----- 33" WIROT STEEL 1-W
 TRUCK TYPE - TRUCK ASSN. - RADIAL SPRING PLANKLESS
 TRUCK SIDES ----- CAST STEEL - INTEGRAL BOXES
 TRUCK BOLSTER ----- CAST STEEL
 SIDE BEARINGS ----- STUCKI

— DF COMPLEMENT —

BELT RAILS ----- 60207 - 8, 60209 - 9
 CROSSMEMBERS ----- 40
 DOORWAY MEMBERS ----- 8
 DECK BOARDS (48" X 106") ----- 20

ROOF ----- IMPROVED SOLID STEEL
 ENDS ----- DREADNAUGHT - 2-PIECE
 SIDES ----- HIGH TENSILE STEEL
 FLOOR ----- WOOD
 UNDERFRAME ----- DURYE
 DOORS ----- YOUNGSTOWN - STEEL
 DOOR FIXTURES ----- CAMEL - ROLLER LIFT
 DRAFT GEAR ----- DURYE
 COUPLER ----- AAR TYPE E
 BRAKE ----- AB
 HAND BRAKE ----- AJAX
 BRAKE SLACK ADJUSTER ----- ROYAL TYPE F

RUNNING BOARDS ----- APEX - STEEL

MARKED CAPACITY, LBS. ----- 110,000
 LIGHT WEIGHT, LBS. (60207) ----- 52,400
 MAX. WEIGHT OF LADING, LBS. (60207) ----- 124,600
 LIGHT WEIGHT, LBS. (60209) ----- 50,600
 MAX. WEIGHT OF LADING, LBS. (60209) ----- 126,400
 CUBICAL CAPACITY, CU. FT. ----- 3888
 LENGTH INSIDE ----- 40'-6"
 WIDTH INSIDE ----- 9'-0"
 HEIGHT INSIDE, AT EAVES ----- 10'-8"

60207 FORMERLY 65196
 60209 " 65136

YEAR BUILT (AS XM BOX CARS) ----- 1939
 BUILDERS ----- PRESSED STEEL CAR CO.
 DF LOADERS APPLIED ----- 1954

REISSUE
 JAN. 2, 1960.
 JAN. 2, 1961.
 JAN. 2, 1962.
 JAN. 2, 1963.
 JAN. 2, 1968.

DENVER & RIO GRANDE WESTERN R.R.
 DF BOX CARS No's. 60250 to 60295
 AAR MECHANICAL DESIGNATION = XL

F-11

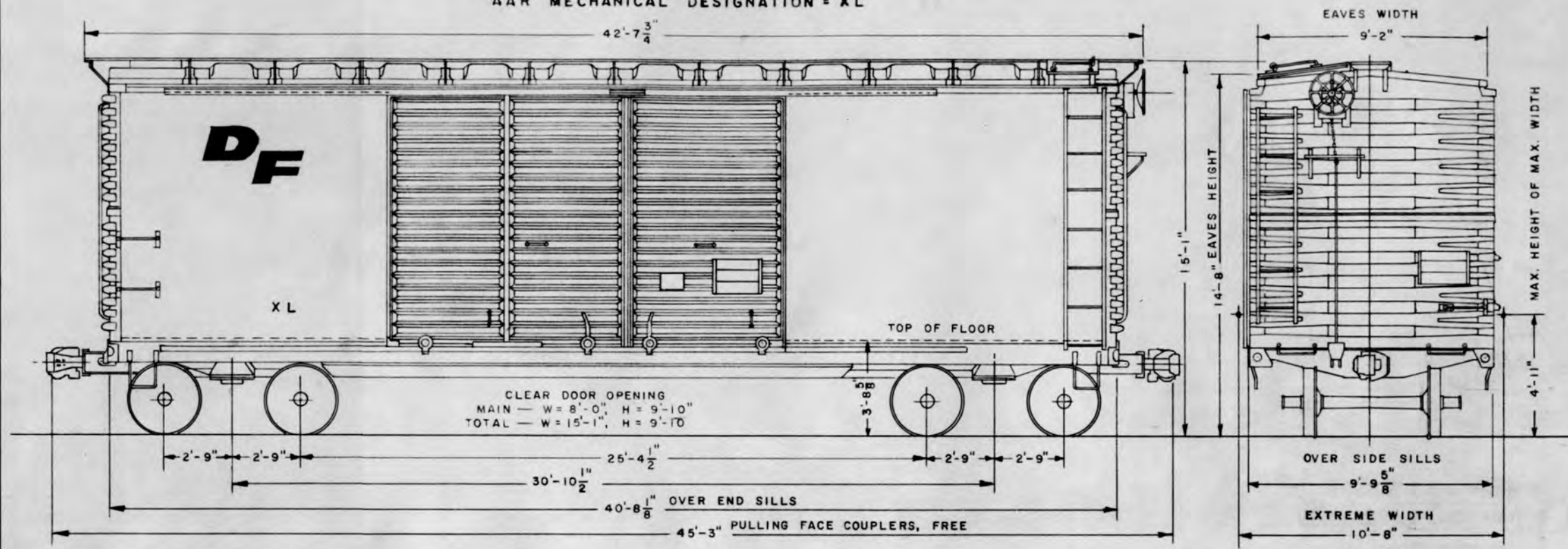

DESCRIPTION

Gauge					4'-8 ¹ / ₂ "			
Journals					5 ¹ / ₂ " X 10"			
Wheels					33" WROT STEEL 1-W			
Truck Type					TRUCK ASSN.—RADIAL—SPRING PLANKLESS			
Truck Sides					CAST STEEL—INTEGRAL BOXES			
Truck Bolster					CAST STEEL			
Side Bearings					STUCKI			
Hanger Type Brake Beams					DAVIS OR CRECO—NO. 15			
Loader Device					DF—2			
60250	WAS	65168	60265	WAS	65159	60281	WAS	65109
60251	"	65116	60266	"	65142	60282	"	65150
60252	"	65125	60267	"	65115	60283	"	65186
60253	"	65160	60268	"	65194	60284	"	65121
60254	"	65135	60269	"	65180	60285	"	65177
60255	"	65181	60270	"	65161	60286	"	65133
60256	"	65197	60271	"	65122	60287	"	65174
60257	"	65113	60272	"	65103	60288	"	65129
			60273	"	65120	60289	"	65100
			60275	"	65123	60290	"	65166
60260	"	65178	60276	"	65185	60291	"	65172
60261	"	65132	60277	"	65111	60292	"	65148
60262	"	65156	60278	"	65199	60293	"	65108
60263	"	65106	60279	"	65132	60294	"	65179
60264	"	65147	60280	"	65176	60295	"	65175

Roof	MURPHY IMPROVED—SOLID STEEL	
Ends	DREADNAUGHT 2-PIECE	
Sides	STEEL	
Underframe	DURYEA—STEEL	
Floor	WOOD	
Doors	YOUNGSTOWN—STEEL	
Door Fixtures	CAMEL ROLLER LIFT	
Dust Guards	ABSCO	
Draft Gear	DURYEA	
Coupler	AAR TYPE E	
Brake	AB	
Hand Brake	AJAX	
Brake Slack Adjuster	ROYAL TYPE F	
Running Boards	APEX—STEEL	

Marked Capacity, LBS.	110,000
Light Weight, LBS., Av.	SEE PAGE F-11-S
Max. Weight of Lading, LBS., Av.	SEE PAGE F-11-S
Cubical Capacity, CU. FT.	3961
Length Inside	40'-6"
Width Inside	9'-2"
Height Inside, at Eaves	10'-11"
Height Inside, at Center	11'-1"
<u>LOADER COMPLEMENT ON FOLLOWING PAGE</u>	
Year Built	1939
Builders	PRESSED STEEL CAR CO.
DF-2 Loaders Applied	1958

DENVER & RIO GRANDE WESTERN R.R.
DF BOX CARS No's. 60250 TO 60295
LOADER COMPLEMENTS

CAR NUMBERS	CAR NUMBERS	CAR NUMBERS	CAR NUMBERS	CAR NUMBERS
<p>60250, 60251, 60253, 60255 60260-60273, 60275-60277 60279</p> <p>LIGHT WEIGHT, LBS., AV. ---51,800 MAX. WT. OF LADING, LBS., AV.---125,200</p> <p>BELT RAILS (DF-2)-----19 CROSSMEMBERS-----14 DOORWAY MEMBERS-----10 DECKBOARDS (24" X 105")-----2 DECKBOARDS (48" X 105")-----2 SWINGBOARDS-----8</p>	<p>60252</p> <p>LIGHT WEIGHT, LBS.-----51,100 MAX. WT. OF LADING, LBS.---125,900</p> <p>BELT RAILS (DF-2)-----19 CROSSMEMBERS-----10 DOORWAY MEMBERS-----10 DECKBOARDS (24" X 106")-----4</p>	<p>60254, 60256</p> <p>LT. WT, LBS. (60254)-----51,800 MAX. WT. LADING, LBS. (60254)---125,200</p> <p>LT. WT, LBS. (60256)-----51,500 MAX. WT. LADING, LBS. (60256)---125,500</p> <p>BELT RAILS (DF-2)-----19 CROSSMEMBERS-----15 DOORWAY MEMBERS-----10 DECKBOARDS (32" X 108")-----10 DECKBOARDS (48" X 108")-----2 SWINGBOARDS-----15</p>	<p>60257</p> <p>LIGHT WEIGHT, LBS.-----52,400 MAX. WT. OF LADING, LBS.-----124,600</p> <p>BELT RAILS (DF-2)-----19 CROSSMEMBERS-----16 DOORWAY MEMBERS-----10</p>	<p>60278</p> <p>LIGHT WEIGHT, LBS.-----52,400 MAX. WT. OF LADING, LBS.-----124,600</p> <p>BELT RAILS (DF-2)-----19 CROSSMEMBERS-----20 DOORWAY MEMBERS-----20 DECKBOARDS (48" X 106")-----20</p>
CAR NUMBERS	CAR NUMBERS	CAR NUMBERS	CAR NUMBERS	CAR NUMBERS
<p>60280, 60281</p> <p>LT. WT., LBS. (60280)-----49,400 MAX. WT. LADING, LBS. (60280)---127,600</p> <p>LT. WT., LBS. (60281)-----50,300 MAX. WT. LADING, LBS. (60281)---126,700</p> <p>BELT RAILS (DF-2)-----19 CROSSMEMBERS-----9 DOORWAY MEMBERS-----8 SWINGBOARDS-----7</p>	<p>60282-60286</p> <p>LIGHT WEIGHT, LBS., AV.-----51,000 MAX. WT. OF LADING, LBS., AV.---126,000</p> <p>BELT RAILS (DF-2)-----19 CROSSMEMBERS-----8 DOORWAY MEMBERS-----8 DECKBOARDS (48" X 105")-----8</p>	<p>60287-60291</p> <p>LIGHT WEIGHT, LBS., AV.-----51,700 MAX. WT. OF LADING, LBS., AV.---125,300</p> <p>BELT RAILS (DF-2)-----19 CROSSMEMBERS-----16 DOORWAY MEMBERS-----8 DECKBOARDS (48" X 105")-----4 SWINGBOARDS-----12</p>	<p>60292-60294</p> <p>LIGHT WEIGHT, LBS., AV.-----51,400 MAX. WT. OF LADING, LBS., AV.---125,600</p> <p>BELT RAILS (DF-2)-----19 CROSSMEMBERS-----10 DOORWAY MEMBERS-----10 DECKBOARDS (24" X 106")-----7 DECKBOARDS (48" X 106")-----9</p>	<p>60295</p> <p>LIGHT WEIGHT, LBS.-----50,800 MAX. WT. OF LADING, LBS.-----126,200</p> <p>BELT RAILS (DF-2)-----19 CROSSMEMBERS-----14 DOORWAY MEMBERS-----10 DECKBOARDS (24" X 106")-----1 DECKBOARDS (48" X 106")-----1 SWINGBOARDS-----8</p>

DENVER & RIO GRANDE WESTERN R.R.

STB BOX CARS No's. 60296 to 60301

AAR MECHANICAL DESIGNATION = XML

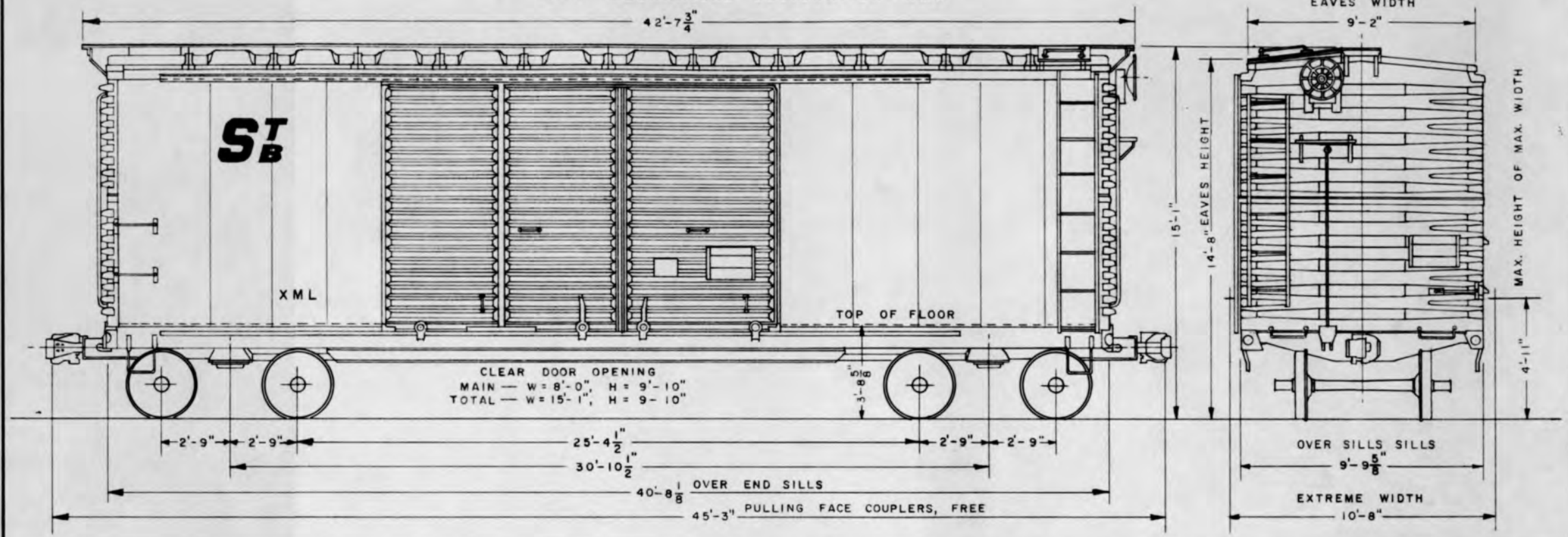

DESCRIPTION

GAUGE ----- 4'-8 1/2"
 JOURNALS ----- 5 1/2" X 10"
 WHEELS ----- 33" WROT STEEL I-W
 TRUCK TYPE-TRUCK ASS'N.-RADIAL-SPRING PLANKLESS
 TRUCK SIDES ----- CAST STEEL-INTEGRAL BOXES
 TRUCK BOLSTER ----- CAST STEEL
 SIDE BEARINGS ----- STUCKI
 HANGER TYPE BRAKE BEAMS - DAVIS OR CRECO-NO. 15
 LOADER DEVICE ----- SPARTON TRI-BELT
 ----- STB COMPLEMENT -----

BELT RAILS ----- 15
 CROSSMEMBERS (ALUMINUM) ----- 14
 DOORWAY MEMBERS ----- 6
 SWINGBOARDS ----- 8
 DECKBOARD (24" X 106") INTERLOCKING ----- 1
 DECKBOARD (48" X 106") INTERLOCKING ----- 1

ROOF ----- MURPHY-IMPROVED SOLID STEEL
 ENDS ----- DREADNAUGHT 2-PIECE
 SIDES ----- STEEL
 UNDERFRAME ----- DURYEA
 FLOOR ----- WOOD

DOORS ----- YOUNGSTOWN-STEEL
 DOOR FIXTURES ----- CAMEL-ROLLER LIFT

DRAFT GEAR ----- DURYEA
 COUPLER ----- ARR TYPE E
 BRAKE ----- AB 1012
 HAND BRAKE ----- AJAX
 BRAKE SLACK ADJUSTER ----- ROYAL TYPE F

RUNNING BOARDS ----- APEX-STEEL

MARKED CAPACITY, LBS. ----- 110,000
 LIGHT WEIGHT, LBS., AV. ----- 50,200
 MAX. WEIGHT OF LADING, LBS., AV. ----- 126,800
 CUBICAL CAPACITY, CU. FT. ----- 3961
 LENGTH INSIDE ----- 40'-6"
 WIDTH INSIDE ----- 9'-2"
 HEIGHT INSIDE, AT EAVES ----- 10'-8"
 HEIGHT INSIDE, AT CENTER ----- 11'-1"

60296	FORMERLY	65192
60297	"	65173
60299	"	65153
60300	"	65190
60301	"	65140

YEAR BUILT ----- 1939
 BUILDERS ----- PRESSED STEEL CAR CO.
 STB LOADERS APPLIED ----- 1960

DENVER & RIO GRANDE WESTERN R.R.

SEL BOX CARS No's. 60302 to 60324

AAR MECHANICAL DESIGNATION = XL

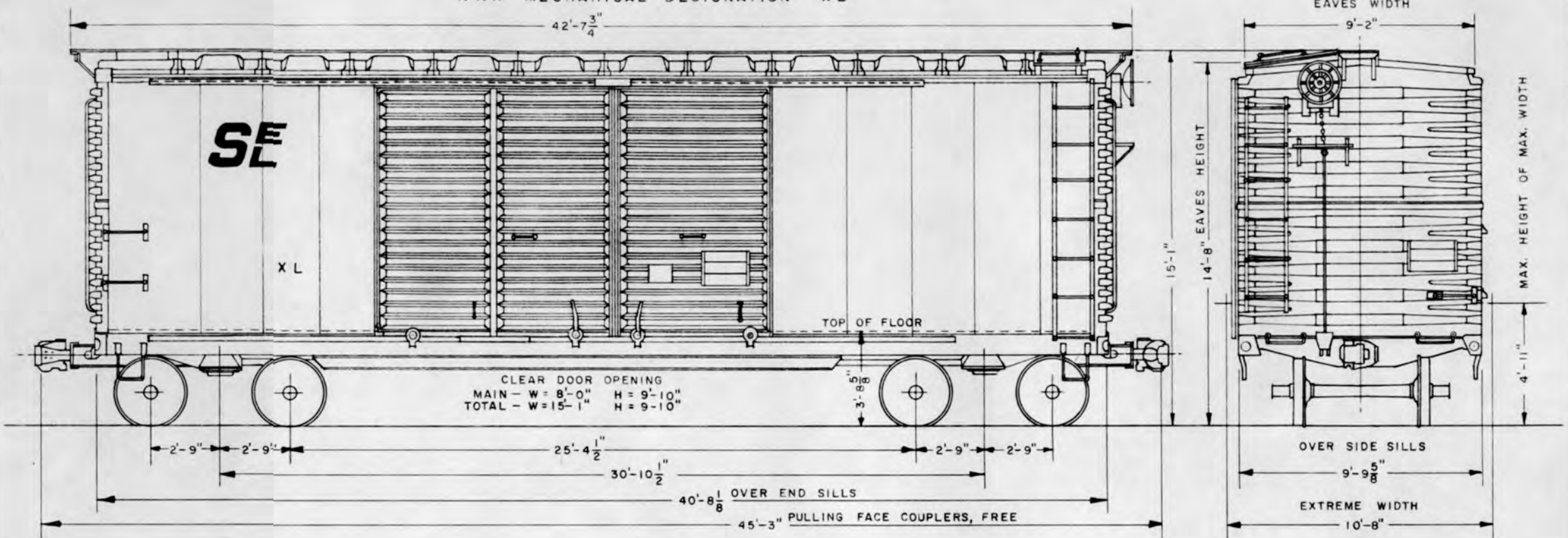

DESCRIPTION

GAUGE ----- 4'-8 1/2"
 JOURNALS ----- 5 1/2" X 10"
 WHEELS ----- 33" WROT STEEL I-W
 TRUCK TYPE -- TRUCK ASS'N. -- RADIAL-SPRING PLANKLESS
 TRUCK SIDES ----- CAST STEEL- INTEGRAL BOXES
 TRUCK BOLSTER ----- CAST STEEL
 SIDE BEARINGS ----- STUCKI
 HANGER TYPE BRAKE BEAMS ----- DAVIS OR CRECO
 LOADER DEVICE ----- SPARTON EASY LOADER

ROOF ----- MURPHY- IMPROVED SOLID STEEL
 ENDS ----- DREADNAUGHT 2-PIECE
 SIDES ----- STEEL
 UNDERFRAME ----- DURYEA
 FLOOR ----- WOOD

MARKED CAPACITY, LBS. ----- 110,000

LIGHT WEIGHT AND MAXIMUM WEIGHT OF LADING
 SHOWN ON FOLLOWING PAGE NO. F-13-S

DOORS ----- YOUNGSTOWN- STEEL
 DOOR FIXTURES ----- CAMEL- ROLLER LIFT

CUBICAL CAPACITY, CU. FT. ----- 3961

DRAFT GEAR ----- DURYEA
 COUPLER ----- AAR TYPE E
 BRAKE ----- AB 1012
 HAND BRAKE ----- AJAX
 BRAKE SLACK ADJUSTER ----- ROYAL TYPE F

LENGTH INSIDE ----- 40'-6"
 WIDTH INSIDE ----- 9'-1 1/4"
 HEIGHT INSIDE, AT EAVES ----- 10'-8"
 HEIGHT INSIDE, AT CENTER ----- 11'-1"

LOADER COMPLEMENT SHOWN ON FOLLOWING PAGE F-13-S

60302	FORMERLY	65198	60314	FORMERLY	65118
60303	"	65158	60316	"	65167
60304	"	65102	60317	"	65170
60305	"	65127	60318	"	65187
60306	"	65110	60319	"	65138
60308	"	65137	60320	"	65171
60309	"	65126	60321	"	65117
60310	"	65155	60322	"	65141
60311	"	65163	60323	"	65119
60312	"	65104	60324	"	65182
60313	"	65157			

RUNNING BOARDS ----- APEX- STEEL

YEAR BUILT ----- 1939
 BUILDERS ----- PRESSED STEEL CAR CO.
 SEL LOADERS APPLIED ----- 1960, 1961.

REISSUE
 JAN. 2, 1962.
 JAN. 2, 1963.
 JAN. 2, 1965.
 JAN. 2, 1968.

DENVER & RIO GRANDE WESTERN R.R.

LOADER COMPLEMENT

SEL BOX CARS No's. 60302 to 60324

CAR NUMBERS	CAR NUMBERS	CAR NUMBERS	CAR NUMBERS	CAR NUMBERS
60302-60306	60308	60309	60310-60314	60316-60324
LIGHT WEIGHT, LBS., AV. ---48,100 MAX. WT. LADING, LBS., AV. ---128,900	LIGHT WEIGHT, LBS. ---50,700 MAX. WT. LADING, LBS. ---126,300	LIGHT WEIGHT, LBS. ---51,600 MAX. WT. LADING, LBS. ---125,400	LIGHT WEIGHT, LBS., AV. ---50,800 MAX. WT. LADING, LBS., AV. ---126,200	LIGHT WEIGHT, LBS., AV. ---50,100 MAX. WT. LADING, LBS., AV. ---126,900
BELT RAILS ---36 CROSSMEMBERS ---16 DOORWAY MEMBERS ---10 DECKBOARDS (30.5" X 108") ---30 SWINGBOARDS (8") ---16 GATES (33" X 107") ---10 GATES (50" X 107") ---2	BELT RAILS ---10 CROSSMEMBERS ---22 DOORWAY MEMBERS ---8 DECKBOARDS (48" X 108") ---8 SWINGBOARDS (8") ---6	BELT RAILS ---10 CROSSMEMBERS ---22 DOORWAY MEMBERS ---8 DECKBOARDS (64" X 108") ---8 SWINGBOARDS (8") ---6	BELT RAILS ---17 CROSSMEMBERS ---28 DOORWAY MEMBERS ---10 DECKBOARDS (48" X 108") ---6 SWINGBOARDS (8.5") ---18	BELT RAILS ---17 CROSSMEMBERS ---28 DOORWAY MEMBERS ---10 DECKBOARDS (48" X 108") ---6 SWINGBOARDS (12") ---6

DENVER & RIO GRANDE WESTERN R.R.
DF BOX CARS No's. 60325, 60326, 60327

AAR MECHANICAL DESIGNATION = XML

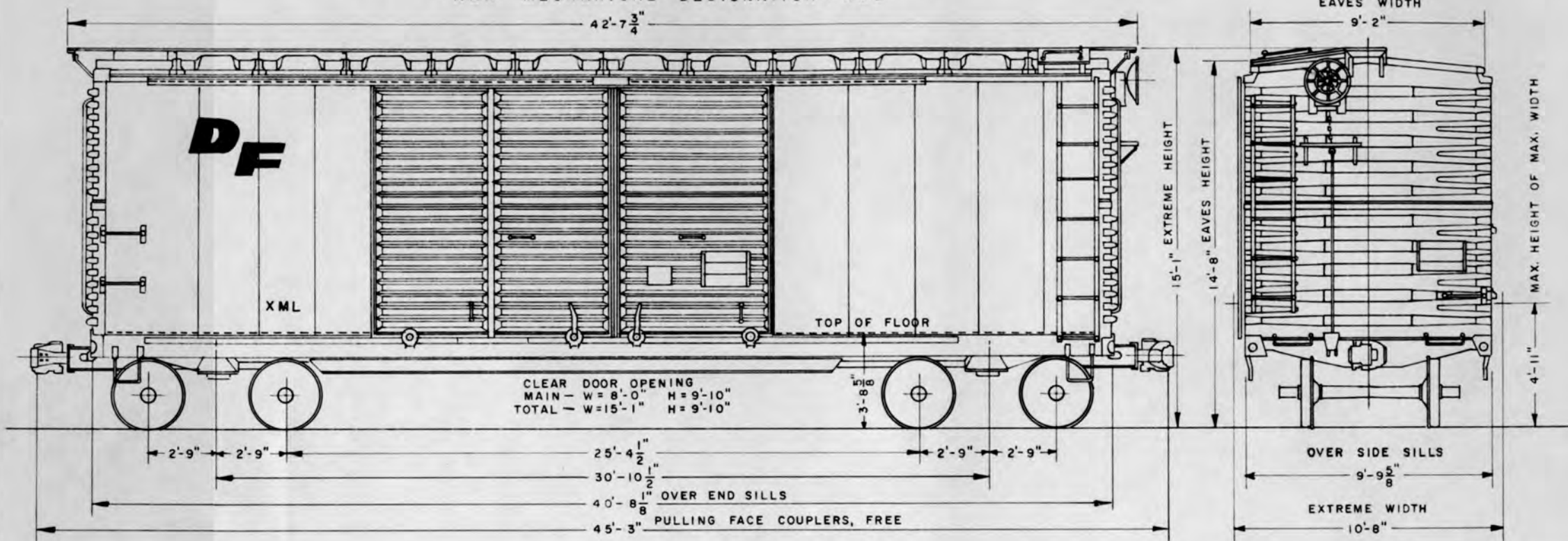

DESCRIPTION

GAUGE	4'-8 1/2"
JOURNALS	5 1/2" X 10"
WHEELS	33" WROT STEEL 1-W
TRUCK TYPE-TRUCK ASS'N.-RADIAL-SPRING PLANKLESS	
TRUCK SIDES	CAST STEEL- INTEGRAL BOXES
TRUCK BOLSTER	CAST STEEL
SIDE BEARINGS	STUCKI
HANGER TYPE BRAKE BEAMS	DAVIS OR CRECO
LOADER DEVICE	DF-2

- DF COMPLEMENT -

BELT RAILS	19
CROSSMEMBERS (ALUMINUM)	20
DOORWAY MEMBERS	6
DECKBOARDS (24" X 104")	4
DECKBOARDS (48" X 104")	4

ROOF	MURPHY-IMPROVED-SOLID STEEL
ENDS	DREADNAUGHT 2-PIECE
SIDES	STEEL
UNDERFRAME	DURYEA
FLOOR	WOOD

DOORS	YOUNGSTOWN-STEEL
DOOR FIXTURES	CAMEL-ROLLER LIFT

DRAFT GEAR	DURYEA
COUPLER	AAR TYPE E
BRAKE	AB 1012
HAND BRAKE	AJAX
BRAKE SLACK ADJUSTER	ROYAL TYPE F

RUNNING BOARDS	APEX-STEEL
----------------	------------

MARKED CAPACITY, LBS.	110,000
LIGHT WEIGHT, LBS., AV.	52,100
MAX. WEIGHT OF LADING, LBS., AV.	124,900
CUBICAL CAPACITY, CU. FT.	3951

LENGTH INSIDE	40'-6"
WIDTH INSIDE	9'-1 3/4"
HEIGHT INSIDE, AT EAVES	10'-8"
HEIGHT INSIDE, AT CENTER	11'-1"

60325	FORMERLY	65151
60326	"	65101
60327	"	65149

YEAR BUILT	1939
BUILDER	PRESSED STEEL CAR CO.
DF LOADERS APPLIED	1962

DENVER & RIO GRANDE WESTERN R.R.

SL BOX CAR No. 60328

AAR MECHANICAL DESIGNATION = XML

F-15

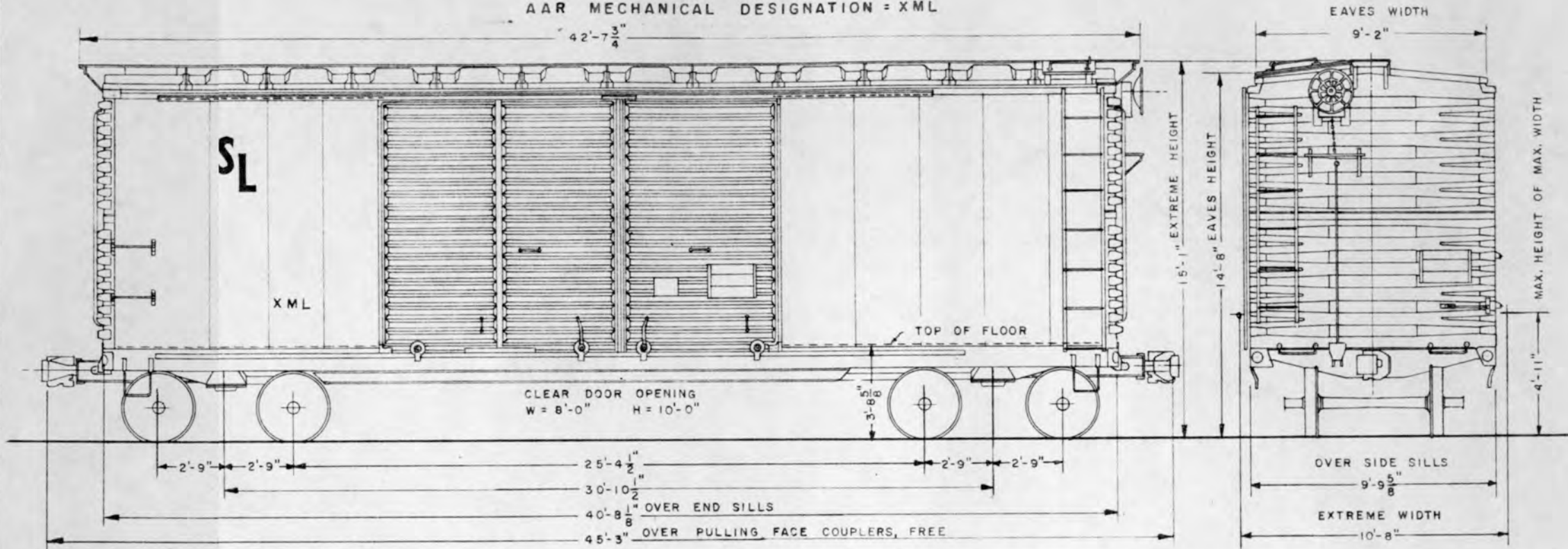

DESCRIPTION

GAUGE	4'-8 1/2"
JOURNALS	5 1/2" x 10"
WHEELS	33" WROT STEEL I-W
TRUCK TYPE	TRUCK ASSN.-RADIAL-SPRING PLANKLESS
TRUCK SIDES	CAST STEEL-INTEGRAL BOXES
TRUCK BOLSTER	CAST STEEL
SIDE BEARINGS	STUCKI
HANGER TYPE BRAKE BEAMS-DAVIS OR CRECO	NO. 15

— TRANSCO "SL" LOADER COMPLEMENT —

BELT RAILS	15
CROSSMEMBERS (ALUMINUM)	26
DOORWAY MEMBERS	10
SWINGBOARDS -8" (OFFSET 2 1/2" x 5 1/2")	10
DECKBOARDS (48" x 105")	10

ROOF	MURPHY IMPROVED-SOLID STEEL
ENDS	DREADNAUGHT 2-PIECE
SIDES	STEEL
UNDERFRAME	DURYEA-STEEL
FLOOR	WOOD
DOORS	YOUNGSTOWN-STEEL
DOOR FIXTURES	CAMEL ROLLER LIFT
INSIDE DOORS	CORRUGATED STEEL-PLYWOOD LINED
DRAFT GEAR	DURYEA
COUPLER	AAR TYPE E
BRAKE	AB
HAND BRAKE	AJAX
BRAKE GEAR REGULATOR	ROYAL TYPE F
RUNNING BOARDS	APEX-STEEL

MARKED CAPACITY, LBS.	110,000
LIGHT WEIGHT, LBS., AV.	51,800
MAX. WEIGHT OF LADING, LBS., AV.	125,200
CUBICAL CAPACITY, CU. FT.	3910
LENGTH INSIDE	40'-6"
WIDTH INSIDE	9'-0 1/2"
HEIGHT INSIDE, AT EAVES	10'-8"
HEIGHT INSIDE, AT CENTER	11'-1"
YEAR BUILT-AS XM BOX CAR NO. 65169	1939
BUILDERS	PRESSED STEEL CAR CO.
SL LOADERS APPLIED	1963

DENVER & RIO GRANDE WESTERN R. R.

SL BOX CAR No. 60329

AAR MECHANICAL DESIGNATION = XML

F-16

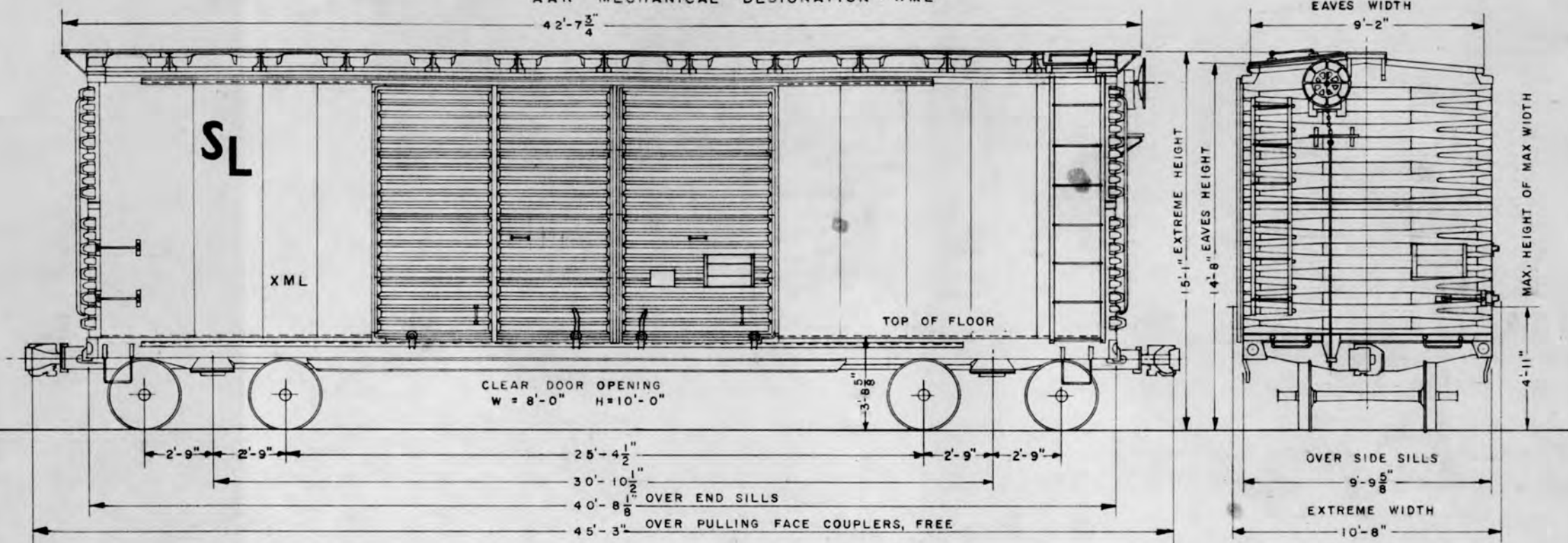

DESCRIPTION

GAUGE ----- 4'-8 1/2"
 JOURNALS ----- 5 1/2" X 10"
 WHEELS ----- 33" WROT STEEL 1-W
 TRUCK TYPE ----- TRUCK ASSM.-RADIAL-SPRING PLANKLESS
 TRUCK SIDES ----- CAST STEEL INTEGRAL BOXES
 TRUCK BOLSTER ----- CAST STEEL
 SIDE BEARINGS ----- STUCKI
 HANGER TYPE BRAKE BEAMS ----- DAVIS OR CRECO ----- NO. 15
 ----- TRANSCO "SL" LOADER COMPLEMENT-----

BELT RAILS ----- 15
 CROSSMEMBERS (ALUMINUM) ----- 20
 DOORWAY MEMBERS ----- 10
 LATERAL SPACERS ----- 10
 SWINGBOARDS - 12" ----- 10
 DECKBOARDS (24" X 105") ----- 6
 DECKBOARDS (36" X 105") ----- 6

ROOF ----- MURPHY IMPROVED-SOLID STEEL
 ENDS ----- DREADNAUGHT 2-PIECE
 SIDES ----- STEEL
 UNDERFRAME ----- DURYEА-STEEL
 FLOOR ----- WOOD
 DOORS ----- YOUNGSTOWN-STEEL
 DOOR FIXTURES ----- CAMEL ROLLER LIFT
 DRAFT GEAR ----- DURYEА
 COUPLER ----- AAR TYPE E
 BRAKE ----- AB
 HAND BRAKE ----- AJAX
 BRAKE GEAR REGULATOR ----- ROYAL TYPE F

RUNNING BOARDS ----- APEX-STEEL

MARKED CAPACITY, LBS. ----- 110,000
 LIGHT WEIGHT, LBS. ----- 50,500
 MAX. WEIGHT OF LADING, LBS. ----- 126,500
 CUBICAL CAPACITY, CU. FT. ----- 3910
 LENGTH INSIDE ----- 40'-6"
 WIDTH INSIDE ----- 9'-0 1/2"
 HEIGHT INSIDE, AT EAVES ----- 10'-8"
 HEIGHT INSIDE, AT CENTER ----- 11'-1"

YEAR BUILT - AS XM BOX CAR NO. 65143 ----- 1939
 BUILDERS ----- PRESSED STEEL CAR CO.
 ASSIGNED TO SPECIAL SERVICE ----- 1963

DENVER & RIO GRANDE WESTERN R.R.

SEL BOX CAR No. 60330

AAR MECHANICAL DESIGNATION = XL

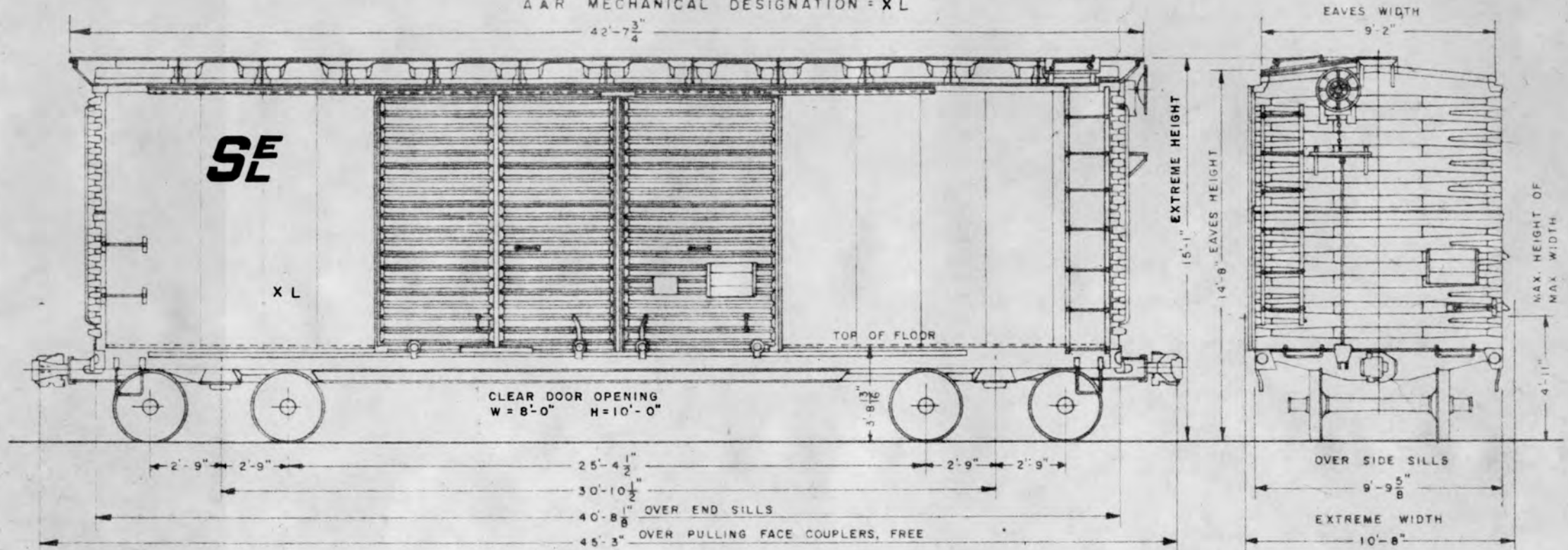

DESCRIPTION

GAUGE	4'-8 1/2"
JOURNALS	5 1/2" X 10"
WHEELS	33" WROT STEEL 1-W
TRUCK TYPE	TRUCK ASS'N.-RADIAL-SPRING PLANKLESS
TRUCK SIDES	CAST STEEL- INTEGRAL BOXES
TRUCK BOLSTER	CAST STEEL
SIDE BEARINGS	STUCKI

— SEL LOADER COMPLEMENT —

BELT RAILS	10
CROSSMEMBERS (ALUMINUM)	22
DOORWAY MEMBERS	8
DECKBOARDS (54" X 104")	25

ROOF	MURPHY IMPROVED-SOLID STEEL
ENDS	DREADNAUGHT 2-PIECE
SIDES	STEEL
UNDERFRAME	DURYEА-STEEL
FLOOR	WOOD AND 3/16" STEEL PLATE
DOORS	YOUNGSTOWN-STEEL
DOOR FIXTURES	CAMEL ROLLER LIFT

DRAFT GEAR	DURYEА
COUPLER	TYPE E
BRAKE	AB
HAND BRAKE	AJAX
BRAKE SLACK ADJUSTER	ROYAL TYPE F

RUNNING BOARDS	APEX-STEEL
----------------	------------

MARKED CAPACITY, LBS.	110,000
LIGHT WEIGHT, LBS.	51,700
MAX. WT. OF LADING, LBS.	125,300
CUBICAL CAPACITY, CU. FT.	3951

LENGTH INSIDE	40'-6"
WIDTH INSIDE	9'-1 3/4"
HEIGHT INSIDE, AT EAVES	10'-8"
HEIGHT INSIDE, AT CENTER	11'-1"

YEAR BUILT - AS XM BOX CAR NO. 65154	1939
BUILDERS	PRESSED STEEL CAR CO.
SEL LOADERS APPLIED	1963

REISSUE
 JULY 1, 1964.
 JAN. 2, 1965.
 JAN. 2, 1968.

DENVER & RIO GRANDE WESTERN R.R.
 CP INSULATED BOX CARS No's. 60715 to 60814
 AAR MECHANICAL DESIGNATION = RBL

F-20

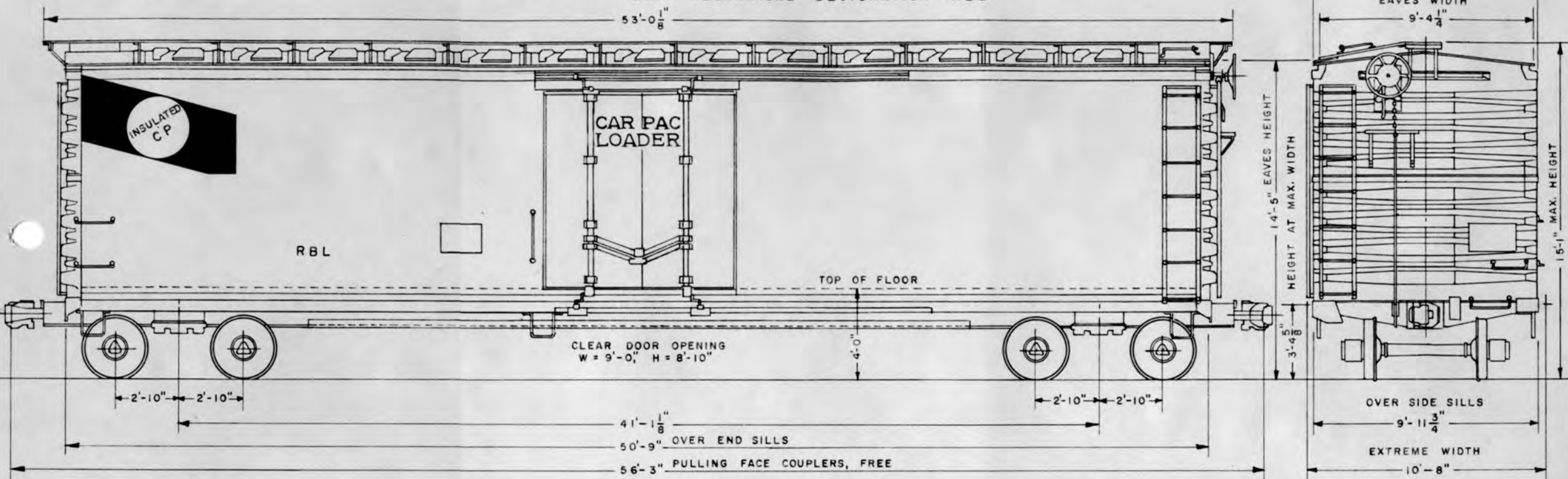

DESCRIPTION

GAUGE ----- 4'-8 1/2" JOURNALS ----- TIMKEN ROLLER BEARINGS - 6" X 11" WHEELS ----- 33" CAST STEEL - 1-W TRUCK TYPE-ASF A-3 RIDE CONTROL, 2 1/2" SPRING TRAVEL TRUCK SIDES ----- NARROW PEDESTAL TYPE SIDE BEARINGS ----- STUCKI ROLLER BRAKE BEAMS-UNIT TYPE NO. 18 ----- BUFFALO		ROOF ----- STANDARD RAILWAY EQUIPMENT CO.-STEEL ENDS ----- S. R. E. CO.-IMPROVED DREADNAUGHT 2-PIECE SIDES ----- STEEL UNDERFRAME ----- WAUGH CUSHION TYPE 170-12 FLOOR ----- WOOD AND 1/8" STEEL PLATE DOORS (SINGLE) ----- SLIDING PLUG TYPE INSULATION ----- SILVERCOTE AND GUSTIN-BACON DRAFT GEAR ----- WAUGHMAT CUSHION TYPE WM-CG-5 COUPLER ----- TYPE E - BOTTOM OPERATING BRAKE ----- AB 1012 HAND BRAKE ----- MINER RUNNING BOARDS ----- U.S. GYPSUM - STEEL	MARKED CAPACITY, LBS. ----- 140,000 LIGHT WEIGHT, LBS., AV. (EXCEPT 60791) ----- 74,600 MAX. WT. LADING, LBS., AV. (EXCEPT 60791) ----- 145,400 LIGHT WEIGHT, LBS. (60791) ----- 75,100 MAXIMUM WEIGHT OF LADING, LBS. (60791) ----- 144,900 CUBICAL CAPACITY, CU. FT. ----- 4555 LENGTH INSIDE ----- 50'-17/16 WIDTH INSIDE ----- 9'-4 3/16 HEIGHT INSIDE ----- 9'-9"
CP LOADER COMPLEMENT			
60715-60790, 60792-60814 BELT RAILS ----- 9 CROSSMEMBERS ----- 25 DOORWAY MEMBERS ----- 8 DECKBOARDS (54" X 108") ----- 16	60791 BELT RAILS ----- 9 CROSSMEMBERS ----- 50 DOORWAY MEMBERS ----- 8 DECKBOARDS ----- 8		YEAR BUILT ----- 1962 BUILDERS ----- PACIFIC CAR AND FOUNDRY CO.

DENVER & RIO GRANDE WESTERN R.R.
 CP INSULATED BOX CARS No's. 60820 to 60869
 AAR MECHANICAL DESIGNATION = RBL

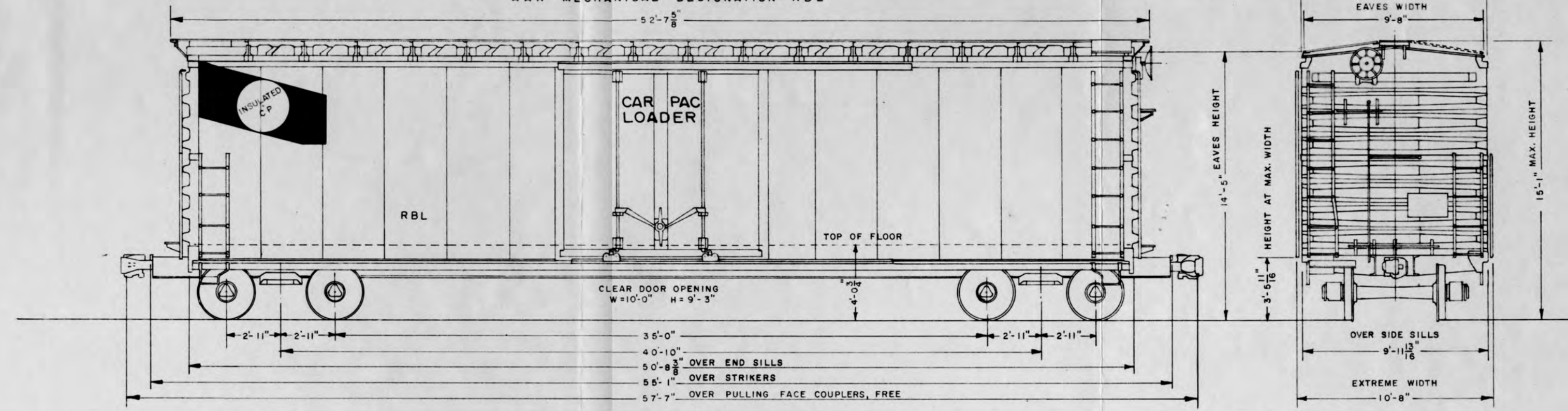

DESCRIPTION

GAUGE	4'-8 ⁵ / ₈ "	ROOF	STANDARD RAILWAY EQUIPMENT CO. - DIAGONAL PANEL - STEEL	MARKED CAPACITY, LBS.	180,000
JOURNALS	6 ¹ / ₂ " X 12" TIMKEN ROLLER BEARINGS	ENDS	STANDARD RAILWAY EQUIPMENT CO. - IMPROVED DREADNAUGHT 2-PIECE	LIGHT WEIGHT, LBS., AV.	81,300
WHEELS	36" WROT STEEL - 2-W	SIDES	STEEL	MAXIMUM WEIGHT OF LADING, LBS., AV.	181,700
AXLES	D-6-D	UNDERFRAME	HYDRA-CUSHION - 20" TRAVEL	CUBICAL CAPACITY, CU. FT.	4,643
TRUCK TYPE	ASF A-3 RIDE CONTROL	FLOOR	BRUCE - DURAWOOD	LENGTH INSIDE	50'-1 ¹ / ₂ "
TRUCK SIDES	NARROW PEDESTAL TYPE	DOORS (SINGLE)	CAMEL - SLIDING PLUG TYPE	WIDTH INSIDE (BETWEEN RUB RAILS)	9'-4 ¹ / ₂ "
TRUCK BOLSTER	CAST STEEL	DOOR FIXTURES	CAMEL	HEIGHT INSIDE	9'-10 ¹⁵ / ₁₆ "
SPRING TRAVEL	3 ¹¹ / ₁₆ "	INSULATION	OWENS-CORNING		
SIDE BEARINGS	ROLLER TYPE - STUCKI	COUPLER	AAR TYPE E	YEAR BUILT	1964
UNIT TYPE BRAKE BEAMS - NO. 24	WABCOPAC	BRAKE	WABCOPAC - 8 ¹ / ₂ " CYLINDER	BUILDER	PACIFIC CAR AND FOUNDRY CO.
	— CP COMPLEMENT —	BRAKE CYLINDER RELEASE VALVE	ORB		
BELT RAILS	9	HAND BRAKE	EQUIPCO		
CROSSMEMBERS (ALUMINUM - 10,000 LB.)	22	RUNNING BOARDS	APEX - STEEL		
DOORWAY MEMBERS	8	END PLATFORMS AND BRAKE STEPS	APEX - STEEL		
DECKBOARDS - INTERLOCKING (24" X 105")	10				
DECKBOARDS - INTERLOCKING (48" X 105")	10				

DENVER & RIO GRANDE WESTERN R. R.
INSULATED BOX CARS No's. 60870 TO 60877

AAR MECHANICAL DESIGNATION = RBL

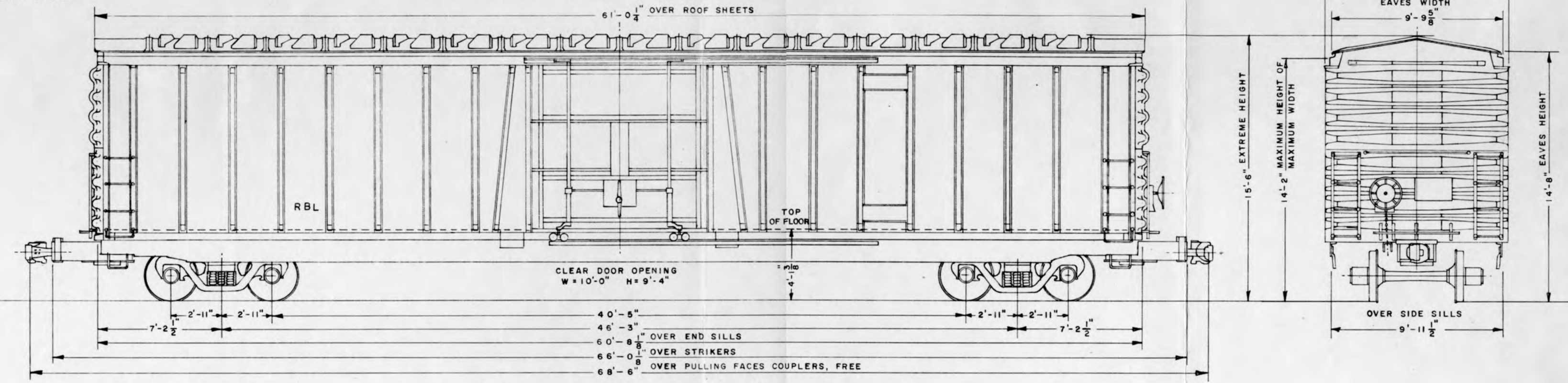

DESCRIPTION

<p>— LOADER COMPLEMENT —</p> <p>LOAD DIVIDERS — EVANS 2-PIECE ————— 2</p> <p>SIDE FILLERS — 8 POSITION ————— EQUIPCO</p> <p>PALLETS ————— 62</p>	<p>GAUGE ————— 4'-8 1/2"</p> <p>JOURNALS ————— 6 1/2" X 12" BRENCO ROLLER BEARNGS</p> <p>WHEELS ————— 36" WROT STEEL 1-W</p> <p>AXLES ————— D-11-1966</p> <p>TRUCK TYPE ————— ASF A-3 RIDE CONTROL, 3 11/16" SPRING TRAVEL</p> <p>TRUCK SIDES ————— NARROW PEDESTAL TYPE</p> <p>SIDE BEARINGS ————— STUCKI DOUBLE ROLLER</p> <p>BRAKE BEAMS ————— WABCOPAC B-3</p> <p>BRAKE SHOES ————— COBRA</p>	<p>ROOF ————— STANDARD RAILWAY EQUIPMENT CO.— DIAGONAL PANEL</p> <p>ENDS ————— STANDARD RAILWAY EQUIPMENT CO.— CORRUGATED STEEL 2-PIECE</p> <p>SIDES ————— YOUNGSTOWN— COPPER BEARING STEEL</p> <p>FLOOR ————— DOWELOC— 2" TAN OAK</p> <p>INSULATION ————— FOAMED IN PLACE</p> <p>DOORS ————— YOUNGSTOWN PLUG-SLIDING TYPE</p> <p>DOOR FIXTURES ————— YOUNGSTOWN</p> <p>UNDERFRAME ————— NATIONAL 3C— 20" TRAVEL</p> <p>DRAFT GEAR (RUBBER) ————— NATIONAL MS-431</p> <p>COUPLER ————— AAR TYPE E</p> <p>BRAKE ————— WABCOPAC B-3, 8 1/2" DIA. CYLINDER- ABD</p> <p>HAND BRAKE ————— AJAX</p> <p>CROSSOVER STEPS ————— APEX</p>	<p>MARKED CAPACITY, LBS. ————— 150,000</p> <p>LIGHT WEIGHT, LBS., AV. ————— 105,500</p> <p>MAXIMUM WEIGHT OF LADING, LBS., AV. ————— 157,500</p> <p>CUBICAL CAPACITY, CU. FT. ————— 5158</p> <p>LENGTH INSIDE ————— 60'-0"</p> <p>WIDTH INSIDE ————— 9'-0"</p> <p>HEIGHT INSIDE — FLOOR TO CEILING TRACK ————— 9'-6.5"</p> <p>HEIGHT INSIDE — FLOOR TO CEILING ————— 9'-11"</p> <p>YEAR BUILT ————— 1967</p> <p>BUILDER ————— C.-B. & Q. R. R.</p>
--	---	---	--

DENVER & RIO GRANDE WESTERN R.R.
INSULATED BOX CARS No's. 60900 to 60999

AAR MECHANICAL DESIGNATION = RBL

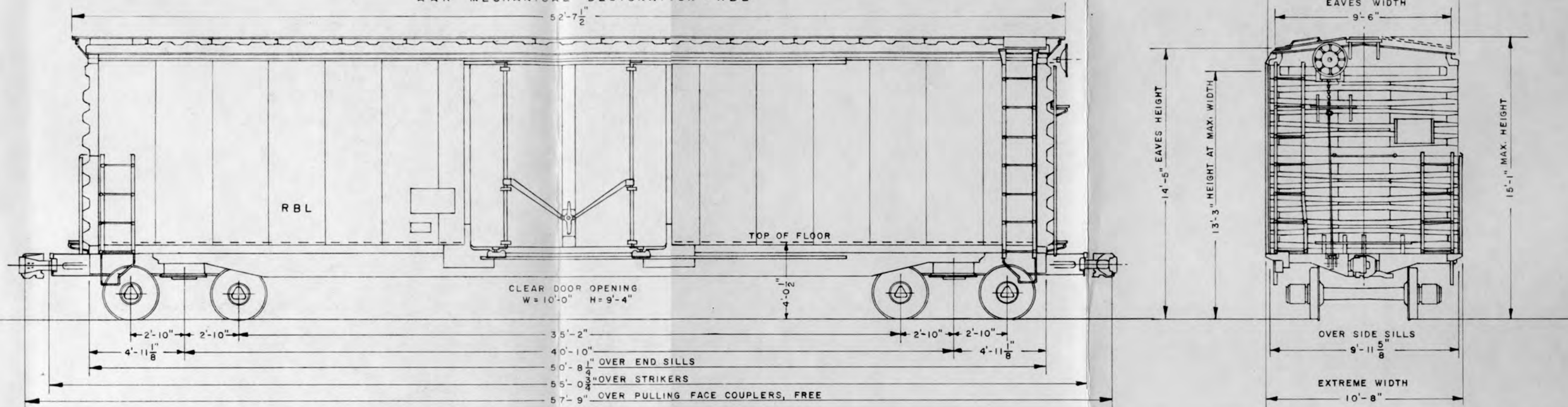

DESCRIPTION

GAUGE	4'-8 1/2"	ROOF	STANDARD RAILWAY EQUIPMENT CO.- DIAGONAL PANEL-STEEL	MARKED CAPACITY, LBS.	137,000
JOURNALS	6" X 11" TIMKEN ROLLER BEARINGS	ENDS	STANDARD RAILWAY EQUIPMENT CO.- IMPROVED DREADNAUGHT 2-PIECE	LIGHT WEIGHT, LBS., AV. (60900-60949)	81,700
WHEELS	33" WROT STEEL 1-W	SIDES	0.10" COPPER BEARING STEEL	MAX. WEIGHT OF LADING, LBS., AV. (60900-60949)	138,300
AXLES	D-6-D	UNDERFRAME (60900-60949)	HYDRA-CUSHION-20" TRAVEL	LIGHT WEIGHT, LBS., AV. (60950-60974)	81,900
TRUCK TYPE	ASF A-3 RIDE CONTROL	UNDERFRAME (60950-60999)	KEYSTONE-20" TRAVEL	MAX. WEIGHT OF LADING, LBS., AV. (60950-60974)	138,100
TRUCK SIDES	NARROW PEDESTAL TYPE	DRAFT GEAR	CARDWELL-WESTINGHOUSE- MARK 50	LIGHT WEIGHT, LBS., AV. (60975-60999)	81,300
SPRING TRAVEL	3 11/16"	FLOOR (60900-60974)	WOOD-DOWELOC	MAX. WEIGHT OF LADING, LBS., AV. (60975-60999)	138,700
		FLOOR (60975-60999)	WOOD-TIMCADEK	CUBICAL CAPACITY, CU. FT.	4,370
SIDE BEARINGS	SINGLE ROLLER-STUCKI	DOORS (SINGLE)	CAMEL-SLIDING PLUG TYPE	CU. CAPY, CU. FT. (SIDE FILLERS EXTENDED, LOAD DIVIDER DOORS AT DOOR POSTS)	4,130
UNIT TYPE BRAKE BEAMS NO. 18	AAR	DOOR FIXTURES	CAMEL	LENGTH INSIDE	50'-1"
		INSULATION	FLOOR-STYROFOAM	WALLS AND CEILING-FIBER GLASS	49'-3"
		COUPLER	6 1/4" X 8" SHANK-AAR TYPE E	WIDTH INSIDE (SIDE FILLERS UP)	9'-3"
		BRAKE	AB 1012	WIDTH INSIDE (SIDE FILLERS FULLY EXTENDED)	8'-3"
		BRAKE CYLINDER RELEASE VALVE	QRB	HEIGHT INSIDE	9'-10 15/16"
		BRAKE SLACK ADJUSTER	ELLCON NATIONAL - MODEL 1340		
		HAND BRAKE	VERTICAL WHEEL-NON-SPIN - 50-AJAX, 50-KLASING	YEAR BUILT	1965
		RUNNING BOARDS, END PLATFORMS, BRAKE STEPS	U.S. GYPSUM CO.- STEEL	BUILDER	GENERAL AMERICAN TRANSPORTATION CORPORATION

INTERIOR ARRANGEMENT

EQUIPPED WITH TWO SETS OF EQUIPCO LOAD DIVIDER DOORS AND EQUIPCO SIDE FILLERS-TYPE D-2

REISSUE
 JAN. 2, 1959.
 JAN. 2, 1965.
 JAN. 2, 1968.

DENVER & RIO GRANDE WESTERN R. R.

BOX CARS No's. 61400 to 61699

AAR MECHANICAL DESIGNATION = XM

F-24-A

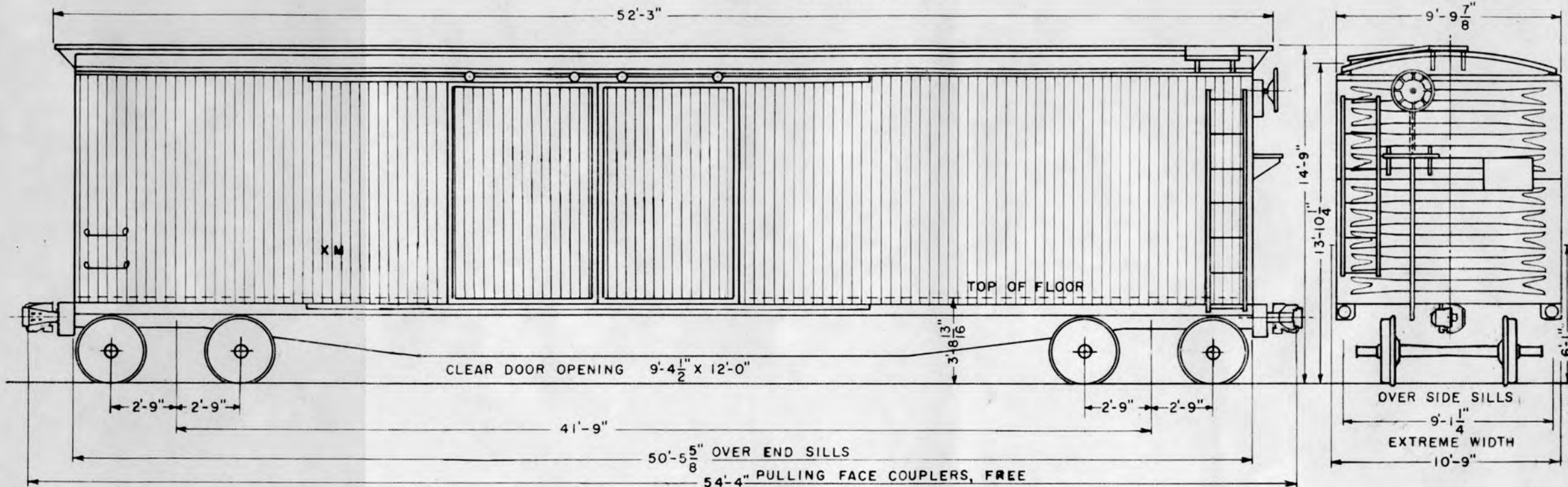

DESCRIPTION

GAUGE -----	4'-8 $\frac{1}{2}$ "	ROOF -----	MURPHY RADIAL-STEEL	MARKED CAPACITY, LBS. -----	110,000
JOURNALS -----	5 $\frac{1}{2}$ " x 10"	ENDS -----	DREADNAUGHT 2-PIECE	LIGHT WEIGHT, LBS., AV. -----	57,600
WHEELS -----	33" CAST IRON	SIDES -----	WOOD-STEEL FRAME	MAX. WEIGHT OF LADING, LBS., AV. -----	111,400
TRUCK TYPE -----	VULCAN-SPRING PLANK	UNDERFRAME -----	STEEL	CUBICAL CAPACITY, CU. FT. -----	4500
TRUCK SIDES -----	CAST STEEL-SEPARATE BOXES	FLOOR -----	WOOD	LENGTH INSIDE -----	50'-0"
TRUCK BOLSTER -----	PRESSED STEEL	DOORS -----	WOOD-STEEL BOUND	WIDTH INSIDE -----	9'-0"
SIDE BEARINGS -----	BARBER	DOOR FIXTURES-CAMEL -----	TOP HUNG OR BOTTOM ROLLER	HEIGHT INSIDE -----	10'-0"
		DRAFT GEAR -----	CARDWELL SPECIAL G-II-AA		
		COUPLER -----	AAR TYPE D	YEAR BUILT -----	1927
		BRAKE -----	AB	BUILDERS -----	MT. VERNON CAR MFG. CO.
		HAND BRAKE -----	AJAX		
		BRAKE GEAR REGULATOR -----	ROYAL TYPE K		
		RUNNING BOARDS -----	WOOD		

DENVER & RIO GRANDE WESTERN R. R.
BOX CARS No's. 62000 to 62049
AAR MECHANICAL DESIGNATION= XM

F-24-B

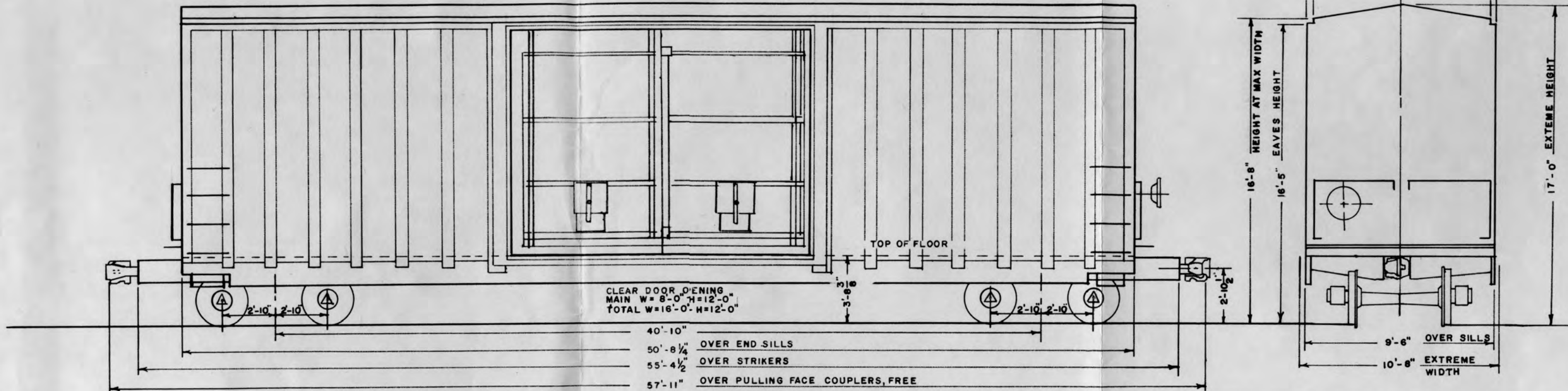

DESCRIPTION

GAUGE ----- 4'-8 1/2"
 JOURNALS ----- 6 XII HYATT-RB
 WHEELS ----- 33" WROT STEEL - 1-W
 AXLES ----- D-11-67
 TRUCK TYPE ----- BARBER STABILIZED
 TRUCK SIDES ----- NATIONAL CASTING
 TRUCK BOLSTER ----- NATIONAL CASTING
 SPRING TRAVEL ----- 3 11/16"
 SIDE BEARINGS ----- STUCKI

ROOF ----- STANRAY
 ENDS ----- STANRAY
 SIDES ----- STEEL
 UNDERFRAME ----- HYDRA-CUSHION- 20" TRAVEL
 LADING STRAP ANCHORS ----- MACLEAN-FOGG
 FLOOR ----- DOWELOC
 DOORS ----- YOUNGSTOWN SLIDING FLUSH - TYPE
 DOOR FIXTURES ----- YOUNGSTOWN
 COUPLER ----- AAR TYPE E
 BRAKE ----- WABCOPAC
 HAND BRAKE ----- UNIVERSAL
 END PLATFORMS ----- MORTON

MARKED CAPACITY, LBS. ----- 146,000
 LIGHT WEIGHT, LBS., AV. ----- 71,500
 MAXIMUM WEIGHT OF LADING, LBS., AV. ----- 148,500
 CUBICAL CAPACITY, CU. FT. ----- 6089
 LENGTH INSIDE ----- 50'-7"
 WIDTH INSIDE ----- 9'-6"
 HEIGHT INSIDE ----- 12'-8"
 YEAR BUILT ----- 1969
 BUILDER ----- GUNDERSON BROS.

DENVER & RIO GRANDE WESTERN R.R.
INSULATED BOX CARS No's. 61000 to 61249

AAR MECHANICAL DESIGNATION = RBL

F-24-C

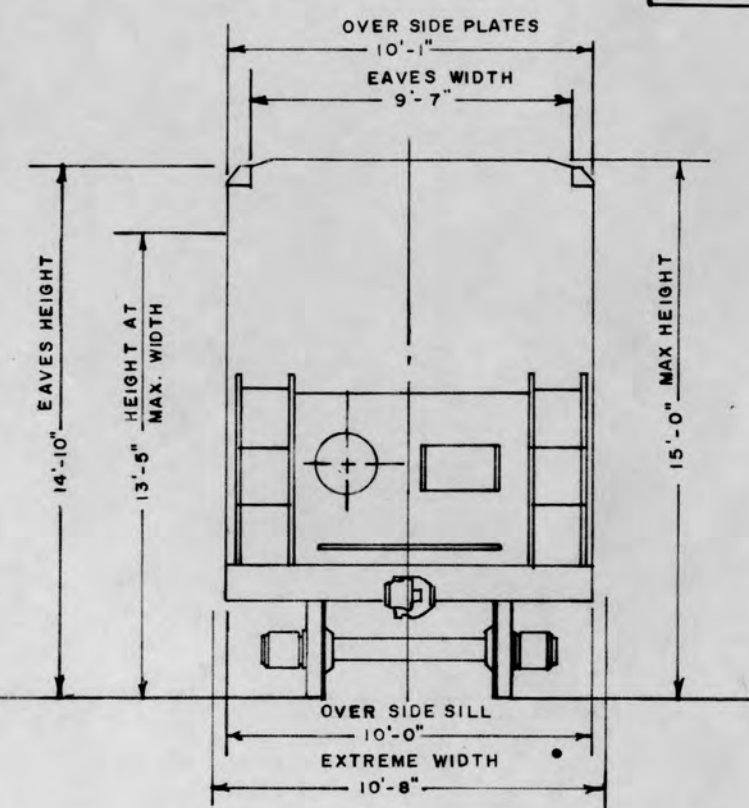
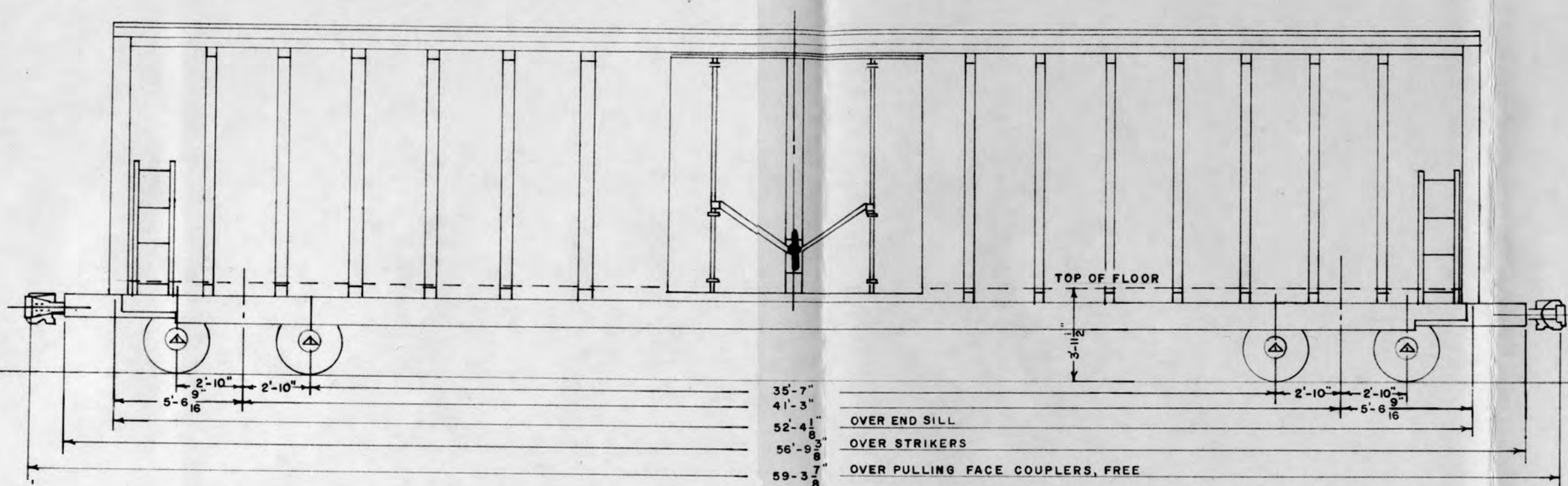

DESCRIPTION

GAUGE	4'-8 1/2"
JOURNALS	6" X 11" TIMKEN AND HYATT R.B.
WHEELS	33" CAST STEEL 1-W
AXLES	D-11-68
TRUCK TYPE	ASF A-3 RIDE CONTROL
SPRING TRAVEL	3 11/16"
SIDE BEARINGS	SINGLE ROLLER - STUCKI
<u>INTERIOR ARRANGEMENT</u>	
EQUIPPED WITH TWO SETS OF EQUIPCO LOAD DIVIDER DOORS AND EQUIPCO SIDE FILLERS - MODEL-HD	

ROOF	STEEL
ENDS	STEEL
SIDES	STEEL
UNDERFRAME	KEYSTONE - 20" TRAVEL
DRAFT GEAR	WAUGH-650-NC-550-MARK 50
FLOOR	WOOD- APITONG
DOORS	SLIDING PLUG TYPE
INSULATION	POLYURETHANE FOAM
COUPLER	AAR TYPE E
BRAKE	WABCO-PAC W/ 8 1/2" CYLINDERS
HAND BRAKE	MINER-61000-61124 AJAX- 61125-61249

MARKED CAPACITY, LBS.	137,000
LIGHT WEIGHT, LBS, AV.	81,300
MAX. WEIGHT OF LADING, LBS., AV.	138,700
CUBICAL CAPACITY, CU. FT.	4,741
CU. CAPY, CU. FT. (SIDE FILLERS EXTENDED, LOAD DIVIDER DOORS AT DOOR POSTS)	3,559
LENGTH INSIDE	51'-6"
LENGTH INSIDE (BETWEEN LOAD DIVIDER DOORS)	50'-6"
WIDTH INSIDE (SIDE FILLERS UP)	9'-1"
WIDTH INSIDE (SIDE FILLERS FULLY EXTENDED)	8'-4"
HEIGHT INSIDE	10'-5"
YEAR BUILT	1969
BUILDER	PACIFIC CAR AND FOUNDRY CO.

DENVER & RIO GRANDE WESTERN R.R.

BOX CARS No's. 63000 TO 63099

AAR MECHANICAL DESIGNATION = XM

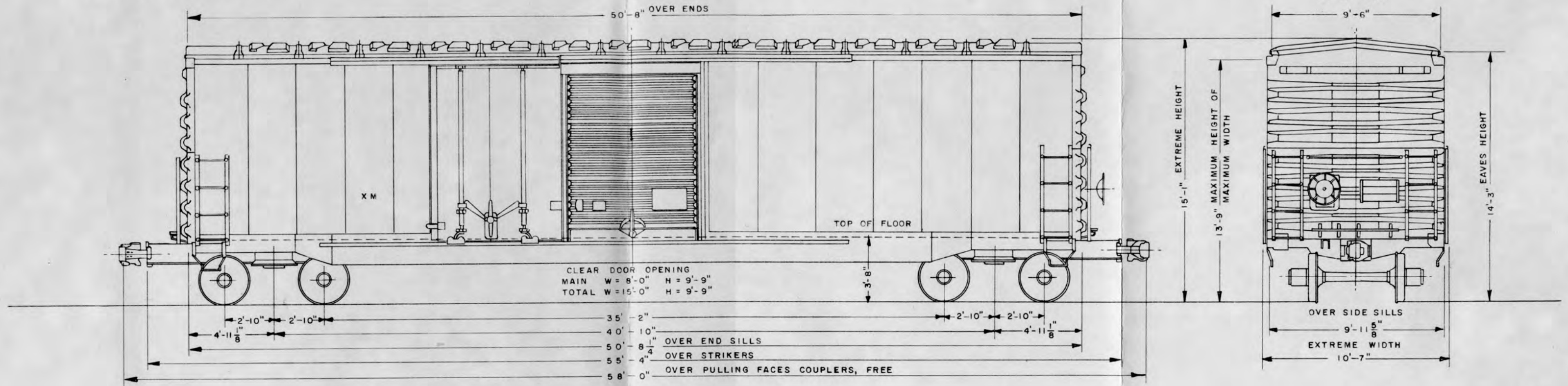

DESCRIPTION

GAUGE	4'-8 1/2"	ROOF	STANDARD RAILWAY EQUIPMENT CO.-DIAGONAL PANEL	MARKED CAPACITY, LBS.	150,000
JOURNALS	6" X 11" TIMKEN ROLLER BEARINGS	ENDS	STANDARD RAILWAY EQUIPMENT CO.-CORRUGATED STEEL 2-PIECE	LIGHT WEIGHT, LBS., AV.	69,300
WHEELS (J-33)	33" WROT STEEL 1-W	END LINING	STEEL	MAXIMUM WEIGHT OF LADING, LBS., AV.	150,700
AXLES	D-11-1967	SIDES	COPPER BEARING STEEL	CUBICAL CAPACITY, CU. FT.	4960
TRUCK TYPE	ASF A-3 RIDE CONTROL, 3 1/16" SPRING TRAVEL	SIDE LINING	T & G YELLOW PINE	LENGTH INSIDE	50'-6"
TRUCK SIDES	NARROW PEDESTAL TYPE	FLOOR	NAILABLE STEEL (10 GA. X 1 3/4") NATIONAL STEEL CO. TYPE EPR-104	WIDTH INSIDE	9'-4"
SIDE BEARINGS	STUCKI SINGLE ROLLER	FLOOR COVERING	ONE COAT OF TOP DRESSING	HEIGHT INSIDE	10'-6"
BRAKE BEAMS	WABCOPAC B-3	DOORS (AUXILIARY)	7 FT. SLIDING-PLUG TYPE	YEAR BUILT	1968
BRAKE SHOES	COMPOSITION-COBRA V-141	DOORS (MAIN)	CORRUGATED STEEL-8 FT. SLIDING TYPE	BUILDER	GENERAL AMERICAN TRANSPORTATION CORP.
		DOOR FIXTURES	CAMEL		
		UNDERFRAME	KEYSTONE-20" TRAVEL		
		DRAFT GEAR	CARDWELL-WESTINGHOUSE MARK 50		
		COUPLER	(B-E60A-HT) 6 1/4" X 8" SHANK, TYPE E HEAD		
		BRAKE	WABCOPAC B-3, 7 1/2" DIA. CYL.-ABD		
		HAND BRAKE	(25 CARS) MINER		
		HAND BRAKE	(75 CARS) AJAX TYPE NO. 5		
		CROSSOVER STEPS	U.S. GYPSUM CO.		

DENVER & RIO GRANDE WESTERN R.R.
BOX CARS No's. 63100 TO 63199

AAR MECHANICAL DESIGNATION

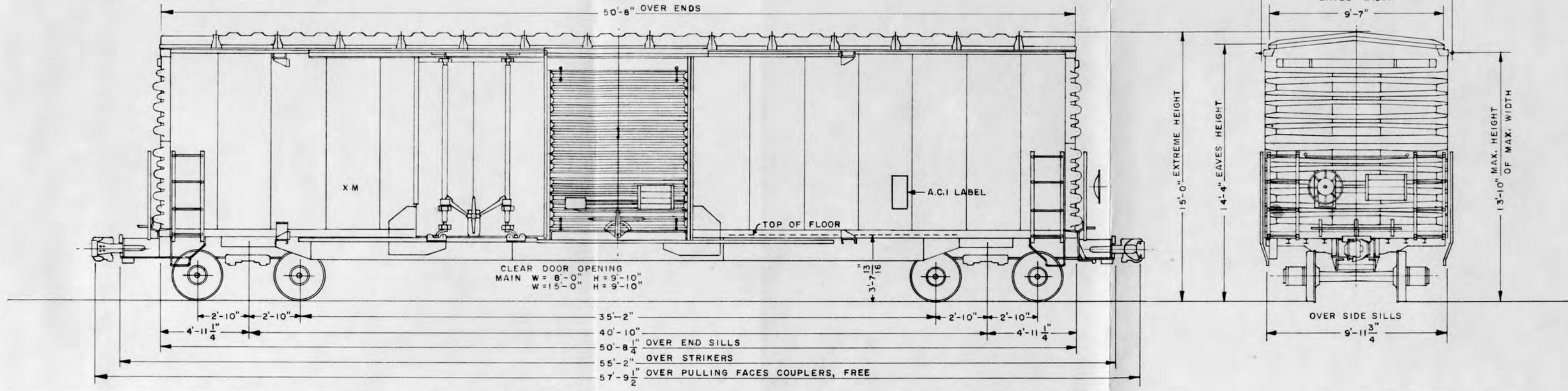

DESCRIPTION

GAUGE -----	4'-8 1/2"	ROOF -----	STANDARD RAILWAY EQUIPMENT CO.-DIAGONAL PANEL	MARKED CAPACITY, LBS.-----	151,000
JOURNALS -----	6" X 11" HYATT ROLLER BEARINGS	ENDS -----	STANDARD RAILWAY EQUIPMENT CO.-CORRUGATED STEEL 2-PIECE	LIGHT WEIGHT, LBS., AV.-----	63,100
WHEELS (63100-63149) -----	(J-33) 33" WROT STEEL 1-W	SIDES -----	COPPER BEARING STEEL	MAXIMUM WEIGHT OF LADING, LBS., AV.-----	156,900
WHEELS (63150-63199) -----	(CJ-33) 33" CAST STEEL 1-W	LINING -----	25/32 T & G.- WOOD	CUBICAL CAPACITY, CU. FT.-----	5009
AXLES -----	D-11-67	FLOOR -----	NAILABLE STEEL (10 GA. X 13/4") NATIONAL STEEL CO. TYPE EPR-104	LENGTH INSIDE -----	50'-6"
TRUCK TYPE -----	ASF A-3 RIDE CONTROL, 3 11/16" SPRING TRAVEL	FLOOR COVERING -----	ONE COAT OF TOP DRESSING	WIDTH INSIDE -----	9'-4"
TRUCK SIDES -----	NARROW PEDESTAL TYPE	DOORS -----	ONE 7 FT. PLUG TYPE AND ONE 8 FT. SLIDING TYPE - YOUNGSTOWN	HEIGHT INSIDE -----	10'-7"
SIDE BEARINGS -----	STUCKI SINGLE ROLLER	DOOR FIXTURES -----	CAMEL	YEAR BUILT -----	1968
BRAKE BEAMS -----	WABCOPAC B-3	UNDERFRAME -----	KEYSTONE - 20" TRAVEL	BUILDER -----	EVANS PRODUCTS CO.
BRAKE SHOES -----	COMPOSITION-V-141	DRAFT GEAR -----	CARDWELL-WESTINGHOUSE MARK 50		
		COUPLER -----	(BE-60A-HT) 6 1/4" X 8" SHANK, TYPE E HEAD		
		BRAKE -----	WABCOPAC B-3, 7 1/2" DIA. CYL. - ABD		
		HAND BRAKE (63100-63149) -----	ELLCON NATIONAL MODEL NO. 1600-2		
		HAND BRAKE (63150-63199) -----	AJAX TYPE NO. 5		
		CROSSOVER STEPS -----	APEX TYPE A-1		

DENVER & RIO GRANDE WESTERN R.R.
BOX CARS No's. 63200 TO 63299

F-25-A

AAR MECHANICAL DESIGNATION = XM

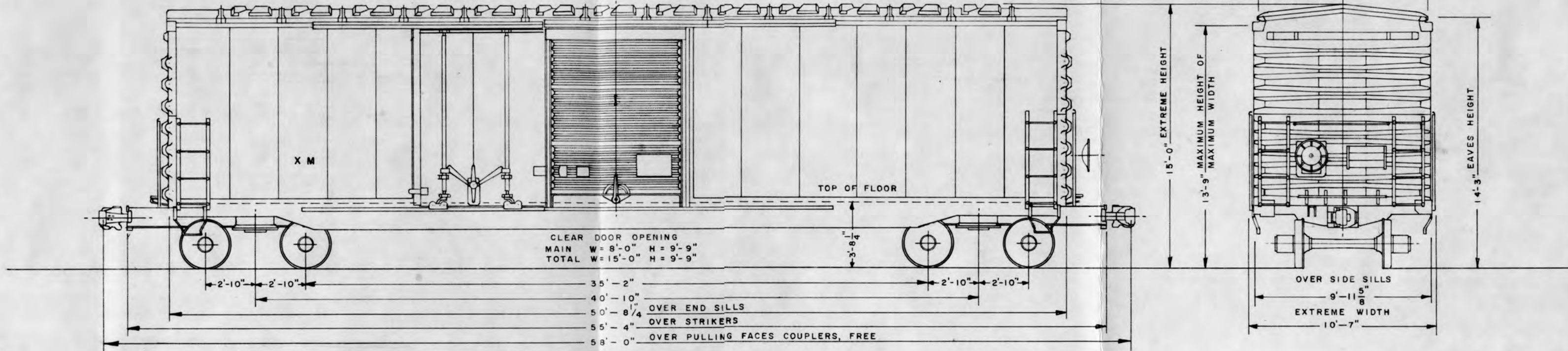

DESCRIPTION

GAUGE _____ 4'-8 1/2"
 JOURNALS _____ 25 CARS HAVE 6" X 11" HYATT ROLLER BEARINGS
 JOURNALS _____ 75 CARS HAVE 6" X 11" TIMKEN ROLLER BEARINGS
 WHEELS (CJ-33) _____ 33" CAST STEEL 1-W
 AXLES _____ D-11-1966
 TRUCK TYPE _____ ASF A-3 RIDE CONTROL, 3 1/16" SPRING TRAVEL
 TRUCK SIDES _____ NARROW PEDESTAL TYPE
 SIDE BEARINGS _____ STUCKI SINGLE ROLLER
 BRAKE BEAMS _____ WABCOPAC B-3
 BRAKE SHOES _____ COMPOSITION-COBRA V-141

ROOF _____ STANDARD RAILWAY EQUIPMENT CO.- DIAGONAL PANEL
 ENDS _____ STANDARD RAILWAY EQUIPMENT CO.- CORRUGATED STEEL 2-PIECE
 END LINING-STEEL _____ THREE VERTICAL PANELS-RAILHEAD
 SIDES _____ COPPER BEARING STEEL
 SIDE LINING _____ T & G YELLOW PINE
 FLOOR _____ DOWELOC
 DOORS (AUXILIARY) 7 FT. SLIDING-PLUG TYPE _____ YOUNGSTOWN
 DOORS (MAIN) CORRUGATED STEEL - 8 FT. SLIDING TYPE _____ YOUNGSTOWN
 DOOR FIXTURES _____ CAMEL
 UNDERFRAME _____ KEYSTONE- 20" TRAVEL
 DRAFT GEAR _____ CARDWELL-WESTINGHOUSE MARK 50
 COUPLER _____ (BE-60A-HT) 6 1/4" X 8" SHANK, TYPE E HEAD
 BRAKE _____ WABCOPAC B-3, 7 1/2" DIA. CYLINDER-ABD
 HAND BRAKE _____ ELLCON NATIONAL - MODEL 1600-2

MARKED CAPACITY, LBS. _____ 151,000
 LIGHT WEIGHT, LBS. AV. _____ 67,700
 MAXIMUM WEIGHT OF LADING, LBS., AV. _____ 152,300
 CUBICAL CAPACITY, CU. FT. _____ 4960
 LENGTH INSIDE _____ 50'-6"
 WIDTH INSIDE _____ 9'-4"
 HEIGHT INSIDE _____ 10'-6"

CROSSOVER STEPS _____ A. O. SMITH CO.

YEAR BUILT _____ 1967
 BUILDER _____ GENERAL AMERICAN TRANSPORTATION CORP.

DENVER & RIO GRANDE WESTERN R.R.
 BOX CARS No's. 63300 to 63499
 AAR MECHANICAL DESIGNATION = XM

F-25-B

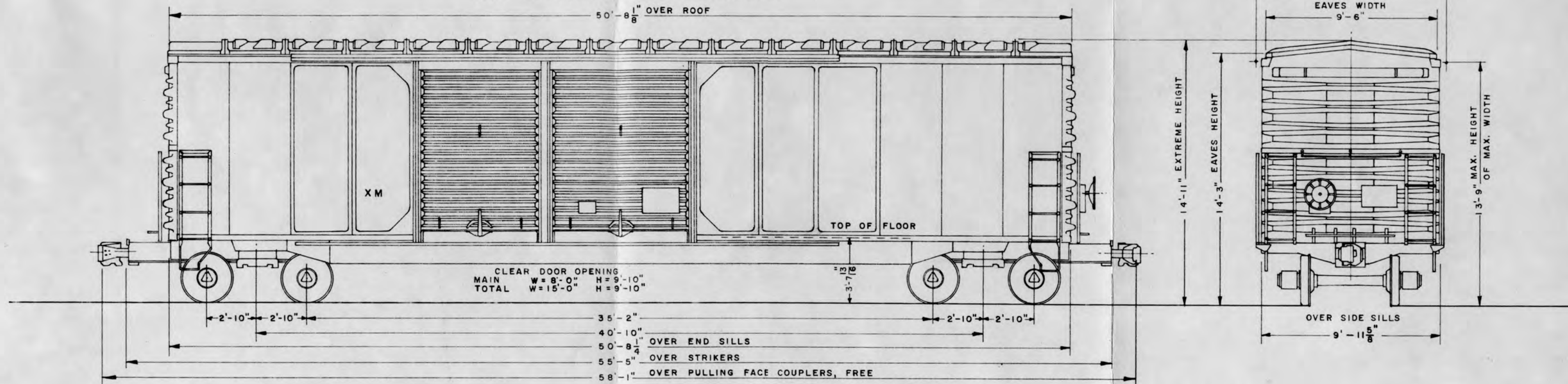

DESCRIPTION

GAUGE ----- 4'-8 1/2"
 JOURNALS ----- 6" X 11" HYATT ROLLER BEARINGS
 WHEELS ----- 33" WROT STEEL 1-W
 AXLES ----- D-11-65
 TRUCK TYPE ----- ASF A-3 RIDE CONTROL, 3 1/16" SPRING TRAVEL
 TRUCK SIDES ----- NARROW PEDESTAL TYPE
 SIDE BEARINGS ----- STUCKI-SINGLE ROLLER
 BRAKE BEAMS ----- UNIT TYPE NO. 24
 BRAKE SHOES ----- AAR 1-A

ROOF ----- STANDARD RAILWAY EQUIPMENT CO. - DIAGONAL PANEL
 ENDS ----- STANDARD RAILWAY EQUIPMENT CO. 2-PIECE
 SIDES ----- COPPER BEARING STEEL
 FLOOR ----- NATIONAL STEEL CORP. ECR-3, 1 3/4" NAILABLE STEEL
 UNDERFRAME ----- KEYSTONE CUSHION-20" TRAVEL
 DRAFT GEAR ----- CARDWELL-WESTINGHOUSE MARK 50
 DOORS ----- CAMEL CORRUGATED STEEL - YOUNGSTOWN TYPE 47
 DOOR FIXTURES ----- CAMEL ROLLER LIFT
 BRAKE ----- WESTINGHOUSE ABD 1012
 BRAKE SLACK ADJUSTER ----- ELLCON NATIONAL - MODEL 1340
 HAND BRAKE ----- 100 CARS - KLASING
 HAND BRAKE ----- 100 CARS - MINER D-3290-XL
 CROSSOVER STEPS ----- U.S. GYPSUM CO.

MARKED CAPACITY, LBS. ----- 145,000
 LIGHT WEIGHT, LBS., AV. ----- 64,400
 MAXIMUM WEIGHT OF LADING, LBS., AV. ----- 145,600
 CUBICAL CAPACITY, CU. FT. ----- 4941
 LENGTH INSIDE ----- 50'-6 1/16"
 WIDTH INSIDE ----- 9'-4 1/16"
 HEIGHT INSIDE, AT EAVES ----- 10'-6"
 HEIGHT INSIDE, AT CENTER ----- 11'-0"
 YEAR BUILT ----- 1966
 BUILDER ----- AMERICAN CAR & FOUNDRY CO.

DENVER & RIO GRANDE WESTERN R.R.

BOX CARS No's. 63700, 63701

AAR MECHANICAL DESIGNATION - XL

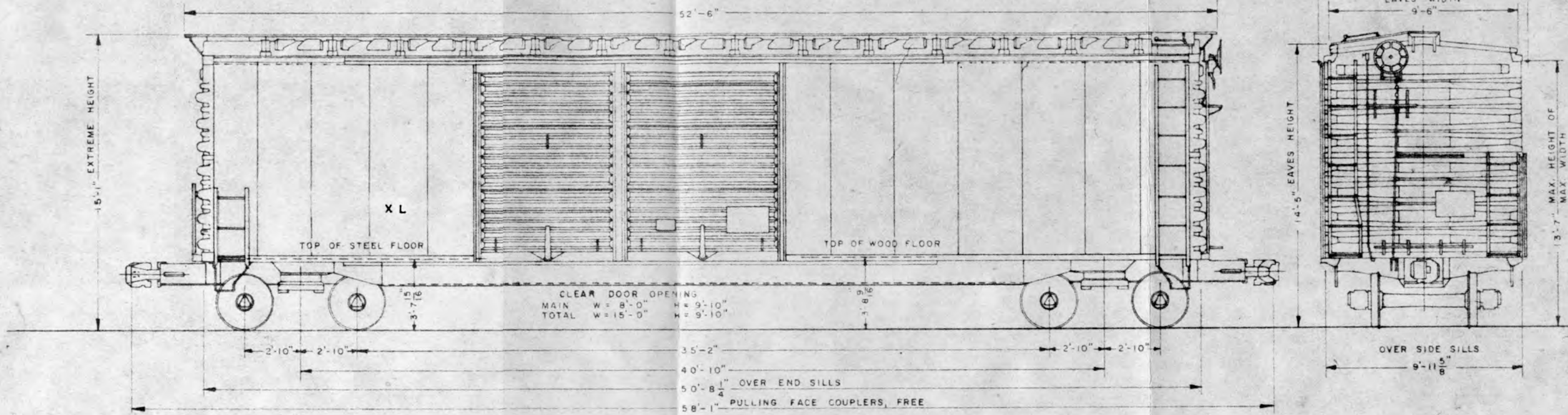

DESCRIPTION

GAUGE	4'-8 1/2"
JOURNALS	6" X 11" TIMKEN ROLLER BEARINGS
WHEELS	33" WROT STEEL 1-W
TRUCK TYPE	ASF A-3 RIDE CONTROL, 3 11/16" SPRING TRAVEL
TRUCK SIDES	SCULLIN, CAST STEEL - INTEGRAL BOXES
TRUCK BOLSTER	SCULLIN - CAST STEEL
SIDE BEARINGS	STUCKI ROLLER
UNIT TYPE BRAKE BEAMS	CHICAGO MALLEABLE CASTINGS CO. - NO. 18

DF LOADER COMPLEMENT

CROSSMEMBERS	4
DOORWAY MEMBERS (MAIN)	2
DOORWAY MEMBERS (TIE-IN TYPE)	2
WALL MEMBERS	2
HOOD RACKS	2
AXLE RACKS (63700 ONLY)	4

ROOF	STANDARD RAILWAY EQUIPMENT CO. - DIAGONAL PANEL
ENDS	STANDARD RAILWAY EQUIPMENT CO. 2-PIECE
SIDES	STEEL

FLOOR	STRAN-NAILABLE STEEL
UNDERFRAME	KEYSTONE CUSHION - 20" TRAVEL
DRAFT GEAR	MINER A-22-XL

DOORS	CAMEL CORRUGATED STEEL - YOUNGSTOWN TYPE 47
DOOR FIXTURES	CAMEL ROLLER LIFT
COUPLER	AAR TYPE E
BRAKE	ABC-1
BRAKE CYLINDER RELEASE VALVE	QRB
HAND BRAKE	MINER
BRAKE SLACK ADJUSTER	WESTINGHOUSE D-12-D
END PLATFORMS	APEX - STEEL
RUNNING BOARDS	U.S. GYPSUM CO. - STEEL

MARKED CAPACITY, LBS.	140,000
LIGHT WEIGHT, LBS.	74,800
MAXIMUM WEIGHT OF LADING, LBS.	145,200

CUBICAL CAPACITY, CU. FT.	4952
LENGTH INSIDE	50'-6"
WIDTH INSIDE	9'-4"
HEIGHT INSIDE, AT EAVES	10'-6"
HEIGHT INSIDE, AT CENTER	11'-0"

YEAR BUILT	1963
BUILDER	AMERICAN CAR AND FOUNDRY CO.
LOADING COMPLEMENT REMOVED	1965

DENVER & RIO GRANDE WESTERN R.R.

DF BOX CARS No's. 63702 to 63707

AAR MECHANICAL DESIGNATION • XL

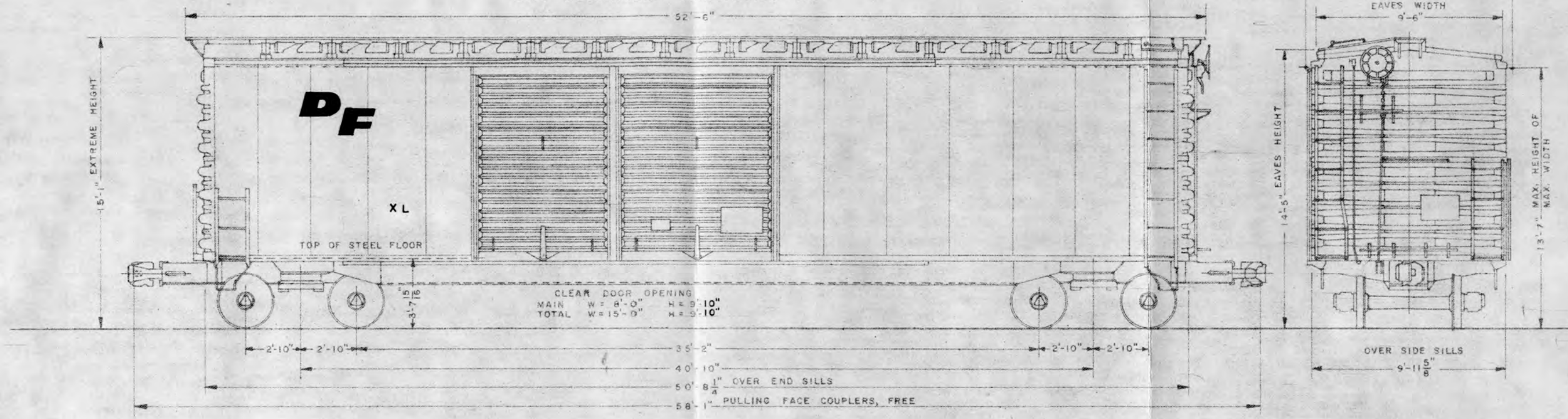

DESCRIPTION

GAUGE -----	4'-8 1/2"	ROOF -----	STANDARD RAILWAY EQUIPMENT CO. - DIAGONAL PANEL	MARKED CAPACITY, LBS. - 63702 -----	142,000
JOURNALS -----	6" X 11" TIMKEN ROLLER BEARING	ENDS -----	STANDARD RAILWAY EQUIPMENT CO. 2-PIECE	MARKED CAPACITY, LBS. - 63703 -----	145,000
WHEELS -----	33" WROT STEEL 1-W	SIDES -----	STEEL	MARKED CAPACITY, LBS. - 63704-63707 -----	140,000
TRUCK TYPE -----	ASF A-3 RIDE CONTROL, 3 11/16" SPRING TRAVEL	FLOOR -----	STRAN-NAILABLE STEEL	LIGHT WEIGHT, LBS. - 63702 -----	77,200
TRUCK SIDES -----	SCULLIN, CAST STEEL-INTEGRAL BOXES	UNDERFRAME -----	KEYSTONE CUSHION-20" TRAVEL	LIGHT WEIGHT, LBS. - 63703 -----	74,200
TRUCK BOLSTER -----	SCULLIN-CAST STEEL	DRAFT GEAR -----	MINER A-22-XL	LIGHT WEIGHT, LBS., AV. - 63704-63707 -----	82,000
SIDE BEARINGS -----	STUCKI ROLLER	DOORS -----	CAMEL CORRUGATED STEEL - YOUNGSTOWN TYPE 47	MAXIMUM WEIGHT OF LADING, LBS. - 63702 -----	142,800
UNIT TYPE BRAKE BEAMS -----	CHICAGO MALLEABLE CASTINGS CO. - NO. 18	DOOR FIXTURES -----	CAMEL ROLLER LIFT	MAXIMUM WEIGHT OF LADING, LBS. - 63703 -----	145,800
		COUPLER -----	AAR TYPE E	MAXIMUM WEIGHT OF LADING, LBS., AV. - 63704-63707 -----	138,000
		BRAKE -----	ABC-1	CUBICAL CAPACITY, CU. FT. -----	4871
		BRAKE CYLINDER RELEASE VALVE -----	ORB	LENGTH INSIDE -----	50'-6"
		HAND BRAKE -----	MINER	WIDTH INSIDE -----	9'-2 1/4"
		BRAKE SLACK ADJUSTER -----	WESTINGHOUSE D-12-D	HEIGHT INSIDE, AT EAVES -----	10'-6"
		END PLATFORMS -----	APEX-STEEL	HEIGHT INSIDE, AT CENTER -----	11'-0"
		RUNNING BOARDS -----	U.S. GYPSUM CO. - STEEL		
LOADER COMPLEMENT ON FOLLOWING PAGE NO. F-28-S.				YEAR BUILT -----	1963
				BUILDERS -----	AMERICAN CAR AND FOUNDRY CO.

DENVER & RIO GRANDE WESTERN R.R.

LOADER COMPLEMENT

DF-2

CAR NUMBERS	CAR NUMBERS	CAR NUMBERS	CAR NUMBERS
<p style="text-align: center;">63702</p> <p>LIGHT WEIGHT, LBS. _____ 77,200 MAXIMUM WEIGHT OF LADING, LBS. _____ 142,800</p> <p>BELT RAILS _____ 19 ALUMINUM CROSSMEMBERS _____ 50 DOORWAY MEMBERS - MAIN _____ 14 DOORWAY MEMBERS - AUXILIARY _____ 14 DOORWAY MEMBERS - TIE-IN _____ 6 SWING BOARDS - 8" _____ 20 DECK BOARDS (48" X 106") _____ 35 DECK BOARDS (24" X 106") _____ 25</p>	<p style="text-align: center;">63703</p> <p>LIGHT WEIGHT, LBS. _____ 74,200 MAXIMUM WEIGHT OF LADING, LBS. _____ 145,800</p> <p>BELT RAILS _____ 19 ALUMINUM CROSSMEMBERS _____ 48 DOORWAY MEMBERS - MAIN _____ 16 DOORWAY MEMBERS - AUXILIARY _____ 16 DOORWAY MEMBERS - TIE-IN _____ 6 DECK BOARDS (48" X 106") _____ 16</p>	<p style="text-align: center;">63704-63707</p> <p>LIGHT WEIGHT, LBS., AV. _____ 82,000 MAXIMUM WEIGHT OF LADING, LBS., AV. _____ 138,000</p> <p>DOORWAY BELTS (DF-2) _____ 6 ALUMINUM CROSSMEMBERS _____ 12 DOORWAY MEMBERS - MAIN _____ 12 DOORWAY MEMBERS - AUXILIARY _____ 12 WALL MEMBER ASSEMBLIES _____ 12 REMOVABLE DOOR POSTS _____ 2 RACKS _____ 9 BASKETS _____ 7</p>	

DENVER & RIO GRANDE WESTERN R.R.

DF BOX CAR No. 63708

AAR MECHANICAL DESIGNATION = XML

F-29

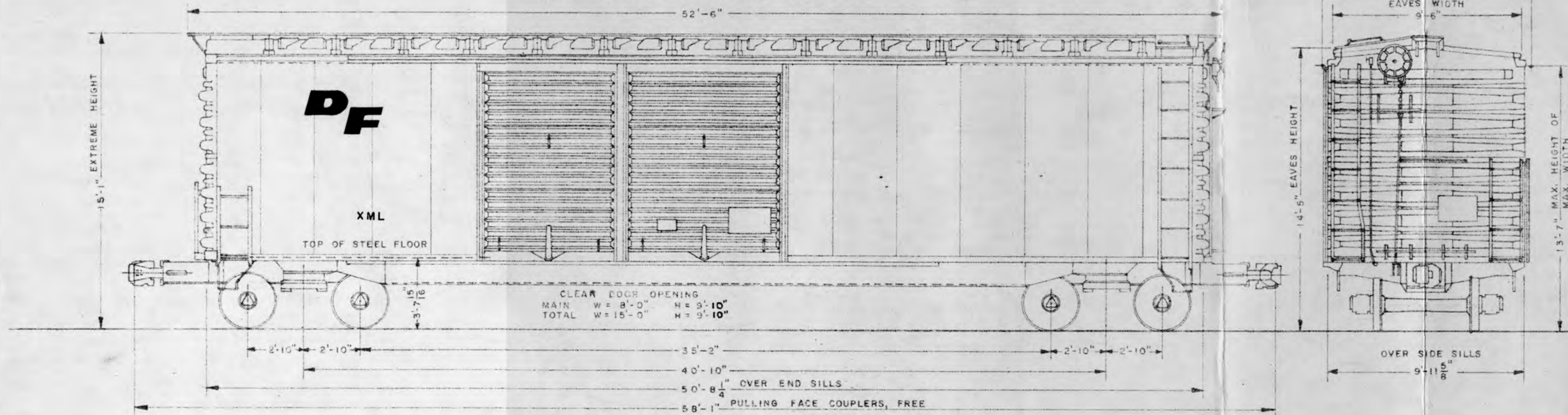

DESCRIPTION

GAUGE -----	4'-8 1/2"	ROOF -----	STANDARD RAILWAY EQUIPMENT CO. - DIAGONAL PANEL	MARKED CAPACITY, LBS. -----	140,000
JOURNALS -----	6" X 11" TIMKEN ROLLER BEARING	ENDS -----	STANDARD RAILWAY EQUIPMENT CO. 2-PIECE	LIGHT WEIGHT, LBS. -----	70,300
WHEELS -----	33" WROT STEEL 1-W	SIDES -----	STEEL	MAX. WEIGHT OF LADING, LBS. -----	149,700
TRUCK TYPE -----	ASF A-3 RIDE CONTROL, 3 11/16" TRAVEL	FLOOR -----	STRAN-NAILABLE STEEL	CUBICAL CAPACITY, CU. FT. -----	4871
TRUCK SIDES -----	SCULLIN, CAST STEEL-INTEGRAL BOXES	UNDERFRAME -----	KEYSTONE CUSHION-20" TRAVEL	LENGTH INSIDE -----	50'-6"
TRUCK BOLSTER -----	SCULLIN-CAST STEEL	DRAFT GEAR -----	MINER A-22-XL	WIDTH INSIDE -----	9'-2 1/4"
SIDE BEARINGS -----	STUCKI ROLLER	DOORS -----	CAMEL CORRUGATED STEEL-YOUNGSTOWN TYPE 47	HEIGHT INSIDE, AT EAVES -----	10'-6"
UNIT TYPE BRAKE BEAMS-----	CHICAGO MALLEABLE CASTINGS CO.-NO. 18	DOOR FIXTURES -----	CAMEL ROLLER LIFT	HEIGHT INSIDE, AT CENTER -----	11'-0"
<u>DF COMPLEMENT</u>		COUPLER -----	AAR TYPE E	YEAR BUILT -----	1963
BELT RAILS -----	9	BRAKE -----	ABC-1	BUILDERS -----	AMERICAN CAR AND FOUNDRY CO.
CROSSMEMBERS - ALUMINUM -----	14	BRAKE CYLINDER RELEASE VALVE -----	QRB		
DOORWAY MEMBERS - MAIN -----	6	HAND BRAKE -----	MINER		
DOORWAY MEMBERS - AUXILIARY (TIE-IN TYPE) -----	6	BRAKE SLACK ADJUSTER -----	WESTINGHOUSE D 212 D		
REMOVABLE DOOR POSTS -----	2	END PLATFORMS -----	APEX-STEEL		
DECK BOARDS - SLOTTED FIR (48" X 106") -----	12	RUNNING BOARDS -----	U.S. GYPSUM CO. - STEEL		

DENVER & RIO GRANDE WESTERN R.R.
AUTOMOBILE WHEEL CARS No's. 63710, 63711
AAR MECHANICAL DESIGNATION = XAP

F-31

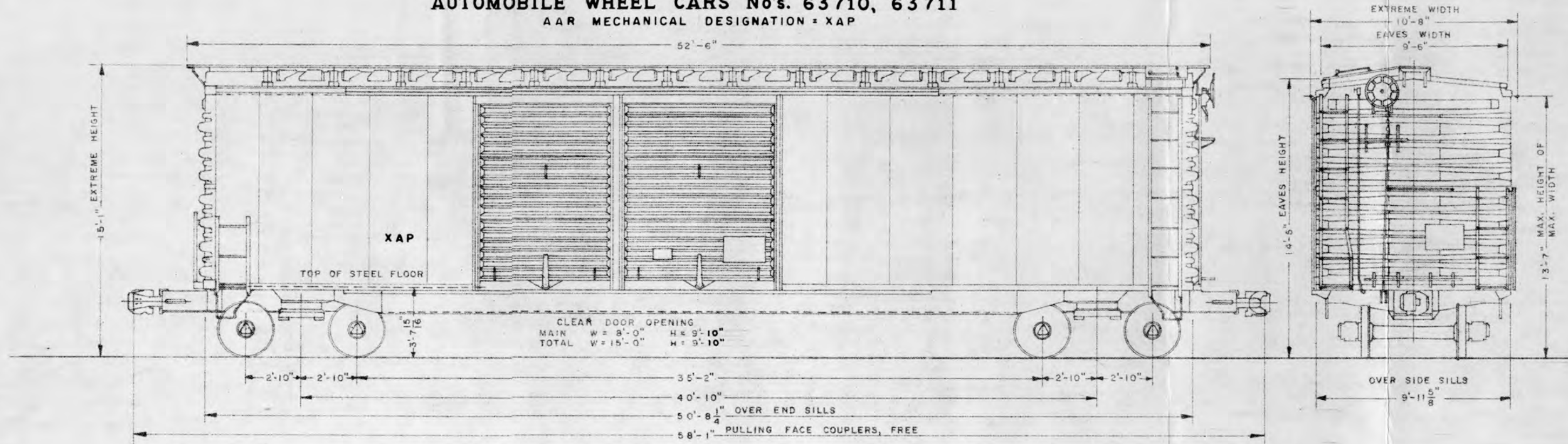

DESCRIPTION

GAUGE ----- 4'-8 1/2"
JOURNALS ----- 6" X 11" TIMKEN ROLLER BEARING
WHEELS ----- 33" WROT STEEL I-W
TRUCK TYPE ----- ASF A-3 RIDE CONTROL, 3 1/16" SPRING TRAVEL
TRUCK SIDES ----- SCULLIN, CAST STEEL - INTEGRAL BOXES
TRUCK BOLSTER ----- SCULLIN, CAST STEEL
SIDE BEARINGS ----- STUCKI ROLLER
UNIT TYPE BRAKE BEAMS ----- CHICAGO MALLEABLE CASTINGS CO. - NO. 18

INTERIOR ARRANGEMENT

EQUIPPED WITH END BULKHEADS AND FLOOR WHEEL-RACKS, TO
SUIT FORD MOTOR CO'S. SPECIFICATIONS.

ROOF ----- CHICAGO RAILWAY EQUIPMENT CO. - DIAGONAL PANEL
ENDS ----- STANDARD RAILWAY EQUIPMENT CO. 2-PIECE
SIDES ----- STEEL
FLOOR ----- STRAN-NAILABLE STEEL
UNDERFRAME ----- KEYSTONE CUSHION - 20" TRAVEL
DRAFT GEAR ----- MINER A-22-XL

DOORS ----- CAMEL CORRUGATED STEEL - YOUNGSTOWN TYPE 47
DOOR FIXTURES ----- CAMEL ROLLER LIFT
COUPLER ----- AAR TYPE E
BRAKE ----- ABC-1
BRAKE CYLINDER RELEASE VALVE ----- QRB
HAND BRAKE ----- MINER
BRAKE SLACK ADJUSTER ----- WESTINGHOUSE D 212 D
END PLATFORMS ----- APEX - STEEL
RUNNING BOARDS ----- U.S. GYPSUM CO. - STEEL

MARKED CAPACITY, LBS. ----- 140,000
LIGHT WEIGHT, LBS. (63710) ----- 74,500
MAX. WEIGHT OF LADING, LBS. (63710) ----- 145,500
LIGHT WEIGHT, LBS. (63711) ----- 72,900
MAX. WEIGHT OF LADING, LBS. (63711) ----- 147,100

CUBICAL CAPACITY, CU. FT. (63710) ----- 4604
CUBICAL CAPACITY, CU. FT. (63711) ----- 4675

LENGTH INSIDE (63710) ----- 48'-4 1/2"
LENGTH INSIDE (63711) ----- 49'-1 1/2"
WIDTH INSIDE ----- 9'-4"
HEIGHT INSIDE, AT EAVES ----- 10'-2 3/8"
HEIGHT INSIDE, AT CENTER ----- 10'-8 3/8"

YEAR BUILT ----- 1963
BUILDERS ----- AMERICAN CAR AND FOUNDRY CO.

DENVER & RIO GRANDE WESTERN R.R.
 SEL BOX CARS No's. 63709, 63712 TO 63799
 AAR MECHANICAL DESIGNATION = XL

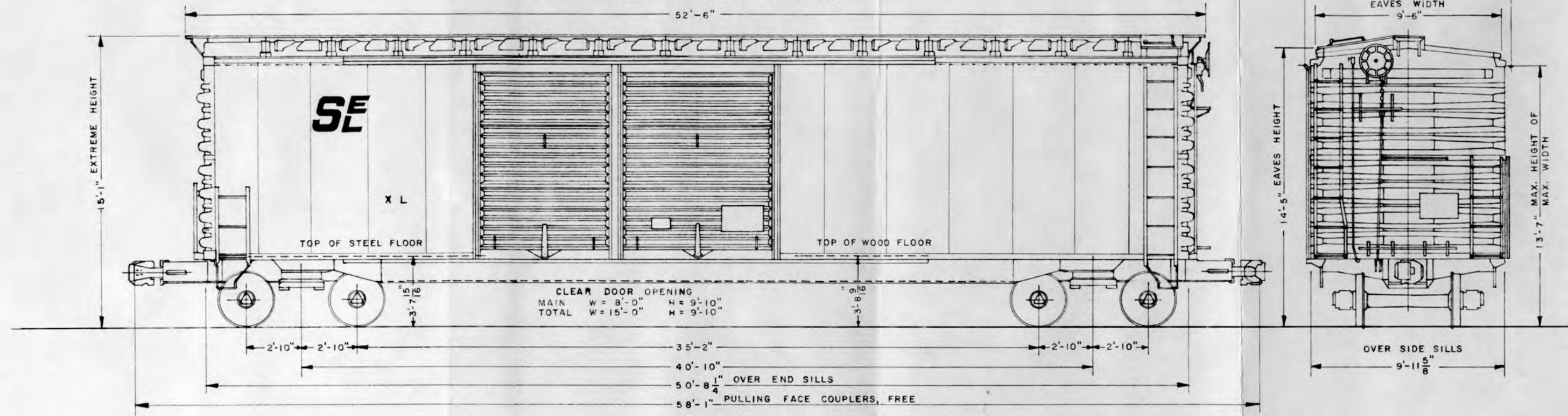

DESCRIPTION

GAUGE	4'-8 1/2"	ROOF	CHICAGO RAILWAY EQUIPMENT CO. - DIAGONAL PANEL	MARKED CAPACITY, LBS.	140,000
JOURNALS	6" X 11" TIMKEN ROLLER BEARING	ENDS	STANDARD RAILWAY EQUIPMENT CO. 2-PIECE	LIGHT WEIGHT, LBS., AV. (63709, 63712-63749)	67,900
WHEELS	33" WROT STEEL I-W	SIDES	STEEL	MAXIMUM WEIGHT OF LADING, LBS., AV. (63709, 63712-63749)	153,100
TRUCK TYPE	ASF A-3 RIDE CONTROL, 3 11/16" SPRING TRAVEL	FLOOR (63709, 63712-63749)	STRAN-NAILABLE STEEL	LIGHT WEIGHT, LBS. (63738)	69,800
TRUCK SIDES	SCULLIN, CAST STEEL- INTEGRAL BOXES	FLOOR (63750-63799)	DOWELOC- WOOD	MAXIMUM WEIGHT OF LADING, LBS. (63738)	150,200
TRUCK BOLSTER	SCULLIN- CAST STEEL	UNDERFRAME	KEYSTONE CUSHION-20" TRAVEL	LIGHT WEIGHT, LBS. (63748)	70,300
SIDE BEARINGS	STUCKI ROLLER	DRAFT GEAR	MINER A-22-XL	MAXIMUM WEIGHT OF LADING, LBS. (63748)	149,700
UNIT TYPE BRAKE BEAMS	CHICAGO MALLEABLE CASTINGS CO.-NO. 18	DOORS	CAMEL CORRUGATED STEEL- YOUNGSTOWN TYPE 47	LIGHT WEIGHT, LBS., AV. (63750-63799)	67,600
LOADER DEVICE- EXCEPT 63738, 63748	SPARTAN EASY LOADER	DOOR FIXTURES	CAMEL ROLLER LIFT	MAXIMUM WEIGHT OF LADING, LBS., AV. (63750-63799)	153,400
LOADER DEVICE- 63738, 63748	EVANS DF	COUPLER	AAR TYPE E	CUBICAL CAPACITY, CU. FT. (63709, 63712-63749)	4,952
LOADER COMPLEMENT		BRAKE	ABC-1	CUBICAL CAPACITY, CU. FT. (63750-63799)	4,928
63709, 63712-63799	63738, 63748	BRAKE CYLINDER RELEASE VALVE	ORB	LENGTH INSIDE	50'-6"
BELT RAILS	4	HAND BRAKE	MINER	WIDTH INSIDE	9'-4"
STUB BELT RAILS-FOR STORAGE	2	BRAKE SLACK ADJUSTER	WESTINGHOUSE D 212 D	HEIGHT INSIDE, AT EAVES (63709, 63712-63749)	10'-6"
CROSSMEMBERS	8	END PLATFORMS	APEX- STEEL	HEIGHT INSIDE, AT EAVES (63750-63799)	10'-5"
		RUNNING BOARDS	U.S. GYPSUM CO.- STEEL	HEIGHT INSIDE, AT CENTER (63709, 63712-63749)	11'-0"
				HEIGHT INSIDE, AT CENTER (63750-63999)	10'-11"
				YEAR BUILT	1963
				BUILDER	AMERICAN CAR AND FOUNDRY CO.

DENVER & RIO GRANDE WESTERN R.R.
BOX CARS No's. 63800 to 63830
AAR MECHANICAL DESIGNATION • XAP

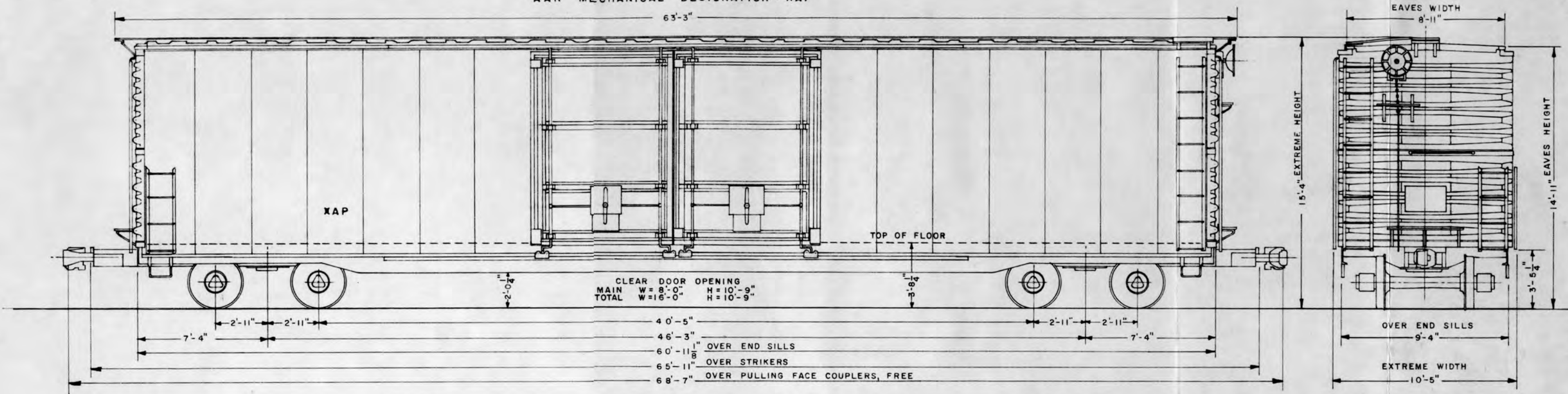

DESCRIPTION

GAUGE -----	4'-8 1/2"	ROOF -----	STANDARD RAILWAY EQUIPMENT CO. - DIAGONAL PANEL	MARKED CAPACITY, LBS. (EXCEPT 63810) -----	176,000
JOURNALS -----	6 1/2" X 12" TIMKEN ROLLER BEARINGS - TYPE AP	ENDS -----	STANDARD RAILWAY EQUIP. CO. - IMPROVED DREADNAUGHT 2-PIECE	LIGHT WEIGHT, LBS., AV. (EXCEPT 63810) -----	86,300
WHEELS -----	36" ROLLED STEEL 2-W	SIDES -----	STEEL	MAXIMUM WEIGHT OF LADING, LBS., AV. (EXCEPT 63810) -----	176,000
AXLES -----	D-6-D	FLOOR -----	DOWELOC - WOOD	MARKED CAPACITY, LBS. - 63810 -----	171,000
SPRING TRAVEL -----	3 11/16"	UNDERFRAME -----	KEYSTONE CUSHION - 20" TRAVEL	LIGHT WEIGHT, LBS. - 63810 -----	91,500
TRUCK TYPE -----	ASF A-3 RIDE CONTROL	DRAFT GEAR -----	CARDWELL - WESTINGHOUSE - MARK 50	MAXIMUM WEIGHT OF LADING, LBS. - 63810 -----	171,500
TRUCK SIDES -----	NARROW PEDESTAL TYPE	DOORS -----	CAMEL - SINGLE SHEATHED - PLUG TYPE	CUBICAL CAPACITY, CU. FT. -----	6013
TRUCK BOLSTER -----	CAST STEEL	DOOR FIXTURES -----	THRALL	LENGTH INSIDE -----	60'-9"
SIDE BEARINGS -----	STUCKI - ROLLER	COUPLER -----	AAR TYPE F SHANK, TYPE E HEAD	WIDTH INSIDE - BETWEEN RUB RAILS -----	9'-2 1/2"
BRAKE BEAMS -----	CRECO - NO. 24	BRAKE -----	ABC-1 1210	WIDTH INSIDE - BETWEEN SIDE POSTS -----	9'-4"
RUB RAILS (EXCEPT 63810) -----	WESTERN RAILWAY EQUIPMENT CO. - 20	BRAKE CYLINDER RELEASE VALVE -----	QRB	HEIGHT INSIDE, AT EAVES -----	10'-9"
RUB RAILS (63810) -----	EVANS	BRAKE SLACK ADJUTER -----	S.A.B. CO	HEIGHT INSIDE, AT CENTER -----	11'-3 7/8"
BULKHEADS (63810) -----	EVANS	HAND BRAKE -----	MINER D-3290-XL	YEAR BUILT -----	1963
		RUNNING BOARDS -----	APEX - STEEL	BUILDERS -----	THRALL CAR MFG. CO.
		END PLATFORMS AND BRAKE STEPS -----	APEX - STEEL		

DENVER & RIO GRANDE WESTERN R.R.
DF BOX CARS No's. 63831, 63832
AAR MECHANICAL DESIGNATION = XL

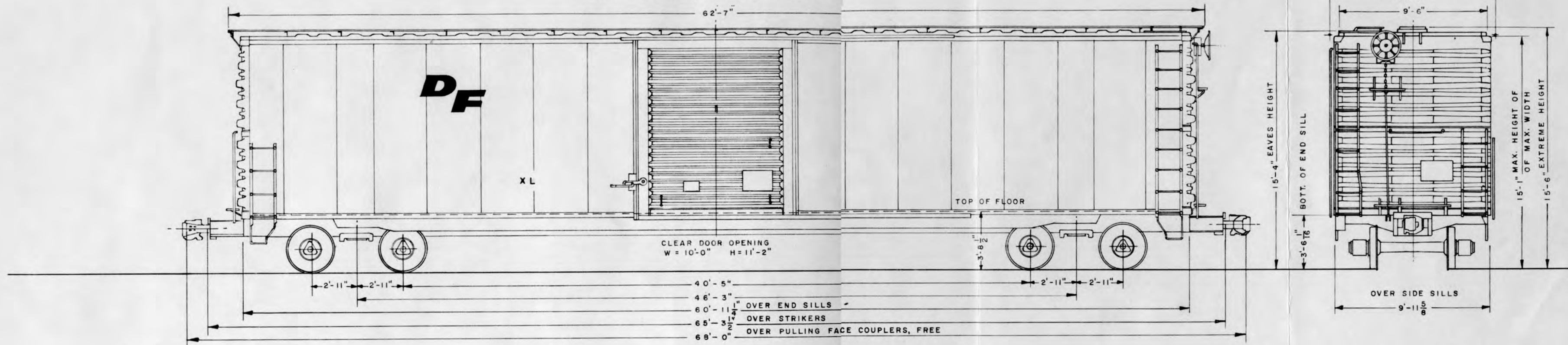

DESCRIPTION

GAUGE	4'-8 1/2"
JOURNALS	6 1/2" x 12" TIMKEN ROLLER BEARINGS
WHEELS	36" WROT STEEL 1-W
AXLES	D-11-65
TRUCK TYPE	ASF A-3 RIDE CONTROL, 3 1/16" SPRING TRAVEL
TRUCK SIDES	NARROW PEDESTAL TYPE
SIDE BEARINGS	STUCKI DOUBLE ROLLER
UNIT TYPE BRAKE BEAMS	NO. 24
BRAKE SHOES	COBRA
LOADER DEVICE	EVANS DF
- DF LOADER COMPLEMENT -	
BELT RAILS (DF-1)	9
CROSSMEMBERS (DF-204450)	40
DOORWAY BARS (DF-204833)	18
DECKBOARDS (48" x 106")	16

ROOF	STANDARD RAILWAY EQUIPMENT CO. - DIAGONAL PANEL
ENDS	STANDARD RAILWAY EQUIPMENT CO. 2-PIECE
SIDES	COPPER BEARING STEEL
FLOOR	DURAWOOD - 3/16" PLATE OVER 2 1/4" T & G YELLOW PINE
UNDERFRAME	ACF FREIGHT-SAVER - 20" TRAVEL
DRAFT GEAR	CARDWELL-WESTINGHOUSE MARK 50
DOORS	CORRUGATED STEEL - YOUNGSTOWN TYPE FR-63
DOOR FIXTURES	CAMEL
COUPLER	AAR TYPE F SHANK - 6 7/16" x 8", TYPE E HEAD
BRAKE	WESTINGHOUSE B-3 - WABCOPAC - 8 1/2" DIA. CYLINDER - ABD
HAND BRAKE	UNIVERSAL
RUNNING BOARDS, END PLATFORMS, BRAKE STEPS	APEX

MARKED CAPACITY, LBS.	176,000
LIGHT WEIGHT, LBS. (63831)	86,300
MAXIMUM WEIGHT OF LADING, LBS. (63831)	176,700
LIGHT WEIGHT, LBS. (63832)	86,600
MAXIMUM WEIGHT OF LADING, LBS. (63832)	176,400
CUBICAL CAPACITY, CU. FT.	6435
LENGTH INSIDE	60'-8 5/8"
WIDTH INSIDE	9'-2 3/8"
HEIGHT INSIDE	11'-6 1/4"
YEAR BUILT	1966
BUILDER	AMERICAN CAR & FOUNDRY CO.

DENVER & RIO GRANDE WESTERN R.R.
DF BOX CARS No's. 63833, 63834
AAR MECHANICAL DESIGNATION = XL

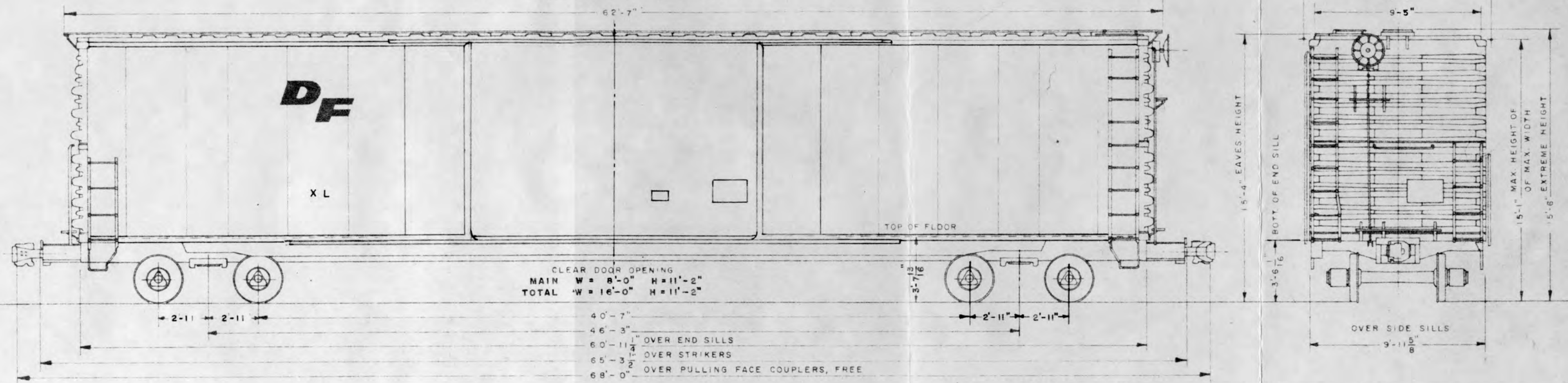

DESCRIPTION

<p>— DF LOADER COMPLEMENT — 63833</p> <p>BELT RAILS (DF-1) ----- 22 CROSSMEMBERS - ALUMINUM (DF-204450) ----- 60 DOORWAY BARS ----- 12 DECKBOARDS ----- 24 REMOVABLE DOOR POSTS (DF-204997) ----- 2 SWINGBOARDS (12" PLASTIC) ----- 8</p>	<p>GAUGE ----- 4'-8 1/2" JOURNALS ----- 6 1/2" X 12" TIMKEN ROLLER BEARINGS WHEELS ----- 36" WROT STEEL 1-W TRUCK TYPE ----- ASF A-3 RIDE CONTROL SPRING TRAVEL ----- 3 1/16" TRUCK SIDES ----- NARROW PEDESTAL TYPE AXLES ----- D-11-65 SIDE BEARINGS ----- STUCKI DOUBLE ROLLER UNIT TYPE BRAKE BEAMS ----- WABCOPAC BRAKE SHOES ----- COBRA</p>	<p>ROOF ----- STANDARD RY. EQUIPMENT CO. - DIAGONAL PANEL ENDS ----- STANDARD RY. EQUIPMENT CO. 2-PIECE SIDES ----- COPPER BEARING STEEL</p> <p>FLOOR ----- TRANSCO NAILABLE STEEL UNDERFRAME ----- ACF FREIGHT SAVER - 20" TRAVEL DRAFT GEAR ----- MINER - TYPE RF-333 DOORS ----- CORRUGATED STEEL - YOUNGSTOWN - SLIDING TYPE DOOR FIXTURES ----- CAMEL COUPLER ----- AAR TYPE F SHANK - 6 7/16" X 8", TYPE E HEAD BRAKE ----- WABCOPAC B3 - 8 1/2" DIA. CYL. WITH AB 1210 HAND BRAKE ----- MINER D-3290-XL</p>	<p>MARKED CAPACITY, LBS. (63833) ----- 180,000 LIGHT WEIGHT, LBS., (63833) ----- 83,000 MAXIMUM WEIGHT OF LADING, LBS. (63833) ----- 180,000</p> <p>MARKED CAPACITY, LBS. (63834) ----- 187,000 LIGHT WEIGHT, LBS. (63834) ----- 75,200 MAXIMUM WEIGHT OF LADING, LBS. (63834) ----- 187,800</p> <p>CUBICAL CAPACITY, CU. FT. ----- 6455</p>
<p>— DF LOADER COMPLEMENT — 63834</p> <p>BELT RAILS (DF-1) AT "B" END ONLY ----- 6 CROSSMEMBERS - ALUMINUM (DF-204450) ----- 30 RUB RAILS ----- 3 BULKHEAD AT "A" END ONLY - OAK BEAMS ----- 6 RACK STOP BARS ----- 8 PROPELLER SHAFT RACKS (DMH-1509) ----- 7 TRANSMISSION RACKS (EMN-1355) ----- 2</p>	<p>UNIT TYPE BRAKE BEAMS ----- WABCOPAC BRAKE SHOES ----- COBRA</p> <p>LOADER DEVICE ----- EVANS DF</p>	<p>RUNNING BOARDS, END PLATFORMS, BRAKE STEPS ----- APEX</p>	<p>LENGTH INSIDE ----- 60'-10 5/8" WIDTH INSIDE ----- 9'-2 5/8" HEIGHT INSIDE ----- 11'-6 15/16"</p> <p>YEAR BUILT ----- 1966 BUILDERS ----- AMERICAN CAR & FOUNDRY CO.</p>

DENVER & RIO GRANDE WESTERN R.R.
DF BOX CARS No's. 63837 to 63842

AAR MECHANICAL DESIGNATION = XL

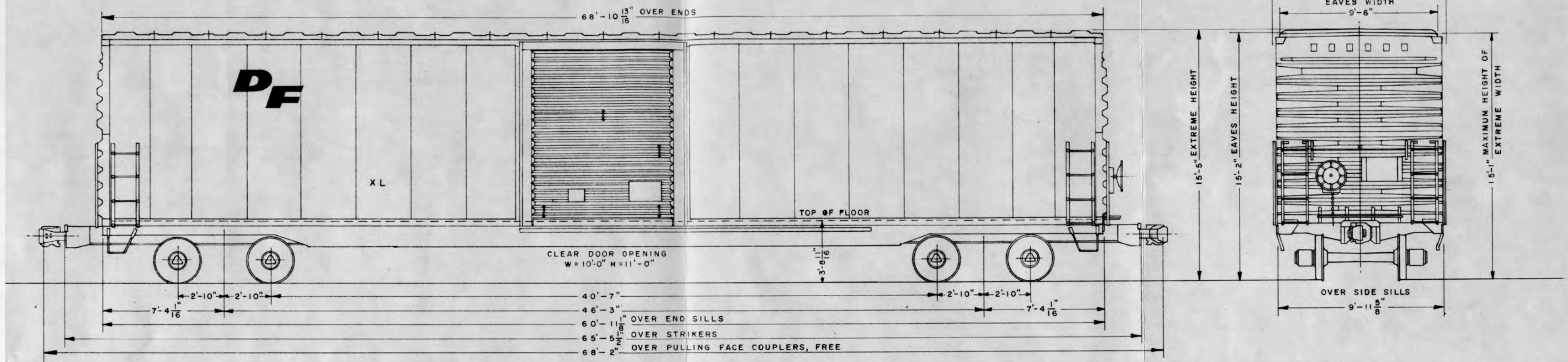

DESCRIPTION

- DF LOADER COMPLEMENT - 63837 - 63840	
RUB RAILS - 6" X 1" _____	PER SIDE - 4
MOVABLE BULKHEADS _____	3
63841, 63842	
BELT RAILS (DF-2) _____	22
CROSSMEMBERS (ALUMINUM) _____	30
DOORWAY BARS (ALUMINUM) _____	8
DOOR POST COVERS _____	4
DECKBOARDS - 48" X 108" X 5/8" _____	10

GAUGE _____	4'-8 1/2"
JOURNALS _____	6" X 11" TIMKEN ROLLER BEARINGS
WHEELS _____	(J-33) 33" WROT STEEL 1-W
AXLES _____	D-11-1965
TRUCK TYPE _____	ASF A-3 RIDE CONTROL, 3 11/16" SPRING TRAVEL
TRUCK SIDES _____	NARROW PEDESTAL TYPE
SIDE BEARINGS _____	HARBIL - ATLAS ADJUSTABLE
BRAKE BEAMS - UNIT TYPE _____	APEX BOXWELD NO. 24
BRAKE SHOES _____	AAR 1-A
LOADER DEVICE _____	EVANS DF-2

ROOF _____	PULLMAN STANDARD - STEEL
ENDS _____	PULLMAN STANDARD - CORRUGATED STEEL 2-PIECE
SIDES _____	COPPER BEARING STEEL
FLOOR _____	2 3/8" YELLOW PINE
FLOOR COVERING _____	DIAMOND TREAD - 3/16" STEEL PLATE
UNDERFRAME _____	KEYSTONE - 20" TRAVEL
DRAFT GEAR _____	NATIONAL - TYPE M-400A
DOORS _____	YOUNGSTOWN - SLIDING TYPE FR-63
DOOR FIXTURES _____	CAMEL
COUPLER _____	AAR TYPE E
BRAKE _____	ABD 1012
BRAKE SLACK ADJUSTER _____	SLOAN
HAND BRAKE _____	KLASING - TYPE 1150
CROSSOVER STEPS _____	APEX - TYPE A-1

MARKED CAPACITY, LBS. (63837-63840) _____	130,000
LIGHT WEIGHT, LBS., AV. (63837-63840) _____	89,600
MAXIMUM WEIGHT OF LADING, LBS., AV. (63837-63840) _____	130,400
MARKED CAPACITY, LBS. (63841, 63842) _____	135,000
LIGHT WEIGHT, LBS., AV. (63841, 63842) _____	84,100
MAXIMUM WEIGHT OF LADING, LBS., AV. (63841, 63842) _____	135,900
CUBICAL CAPACITY, CU. FT. (63837-63840) _____	6638
CUBICAL CAPACITY, CU. FT. (63841-63842) _____	6426
LENGTH INSIDE _____	60'-8 15/16"
WIDTH INSIDE (63837-63840) _____	9'-4"
WIDTH INSIDE (63841, 63842) _____	9'-5"
HEIGHT INSIDE - AT EAVES _____	11'-4"
HEIGHT INSIDE - AT CENTER _____	11'-4 3/4"
YEAR BUILT _____	1966
BUILDER _____	PULLMAN STANDARD CAR MFG. CO.

DENVER & RIO GRANDE WESTERN R.R.
DF BOX CARS No's. 63843 to 63847

AAR MECHANICAL DESIGNATION = XL

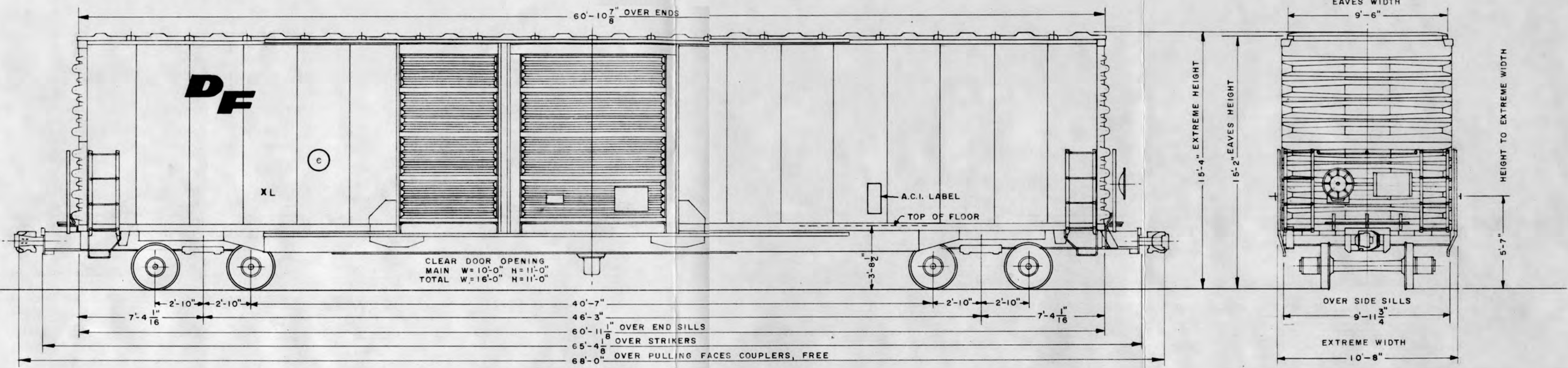

DESCRIPTION

<p>— DF LOADER COMPLEMENT —</p> <p>BELT RAILS ----- 9</p> <p>CROSSMEMBERS (ALUMINUM) ----- 80</p> <p>DOORWAY MEMBERS - MAIN ----- 12</p> <p>DOORWAY MEMBERS - AUXILIARY (TIE-IN TYPE) ----- 6</p> <p>SLIDING DOOR POSTS ----- 2</p> <p>DECKBOARDS - 42" X 106" ----- 45</p>		<p>GAUGE ----- 4'-8 1/2"</p> <p>JOURNALS ----- 6" X 11" TIMKEN ROLLER BEARINGS</p> <p>WHEELS ----- (M-33) 33" WROT STEEL 2-W</p> <p>AXLES ----- D-11-67</p> <p>TRUCK TYPE ----- ASF A-3 RIDE CONTROL, 3 11/16" SPRING TRAVEL</p> <p>TRUCK SIDES ----- NARROW PEDESTAL TYPE</p> <p>SIDE BEARINGS ----- STUCKI SINGLE ROLLER</p> <p>BRAKE BEAMS ----- CRECO NO. 24</p> <p>BRAKE SHOES ----- AAR I-A</p> <p>LOADER DEVICE ----- EVANS DF</p>	<p>ROOF ----- STANDARD RAILWAY EQUIPMENT CO. - DIAGONAL PANEL</p> <p>ENDS ----- STANDARD RAILWAY EQUIPMENT CO. - CORRUGATED STEEL 2-PIECE</p> <p>SIDES ----- COPPER BEARING STEEL</p> <p>FLOOR ----- 2 1/4" T & G - YELLOW PINE</p> <p>FLOOR COVERING ----- JAL-TREAD - 3/16" STEEL PLATE</p> <p>UNDERFRAME ----- HYDRA-CUSHION - 20" TRAVEL</p> <p>DRAFT GEAR ----- MINER A-22-XL</p> <p>DOORS ----- YOUNGSTOWN - SLIDING TYPE FR-63</p> <p>DOOR FIXTURES ----- CAMEL</p> <p>COUPLER ----- TYPE F SHANK, TYPE E HEAD</p> <p>BRAKE ----- NEW YORK AIR BRAKE CO. - ABD 1012</p> <p>BRAKE SLACK ADJUSTER ----- SAB</p> <p>HAND BRAKE ----- AJAX</p> <p>CROSSOVER STEPS ----- APEX</p>	<p>MARKED CAPACITY, LBS. ----- 126,000</p> <p>LIGHT WEIGHT, LBS., AV. ----- 92,700</p> <p>MAXIMUM WEIGHT OF LADING, LBS., AV. ----- 127,300</p> <p>CUBICAL CAPACITY, CU. FT. ----- 6390</p> <p>LENGTH INSIDE ----- 60'-9"</p> <p>WIDTH INSIDE ----- 9'-2 1/2"</p> <p>HEIGHT INSIDE - AT EAVES ----- 11'-4"</p> <p>YEAR BUILT ----- 1968</p> <p>BUILDER ----- EVANS PRODUCTS CO.</p>
---	--	---	---	---

DENVER & RIO GRANDE WESTERN R.R.
DF BOX CARS No's. 63880 to 63887
AAR MECHANICAL DESIGNATION = XL

F-33-G

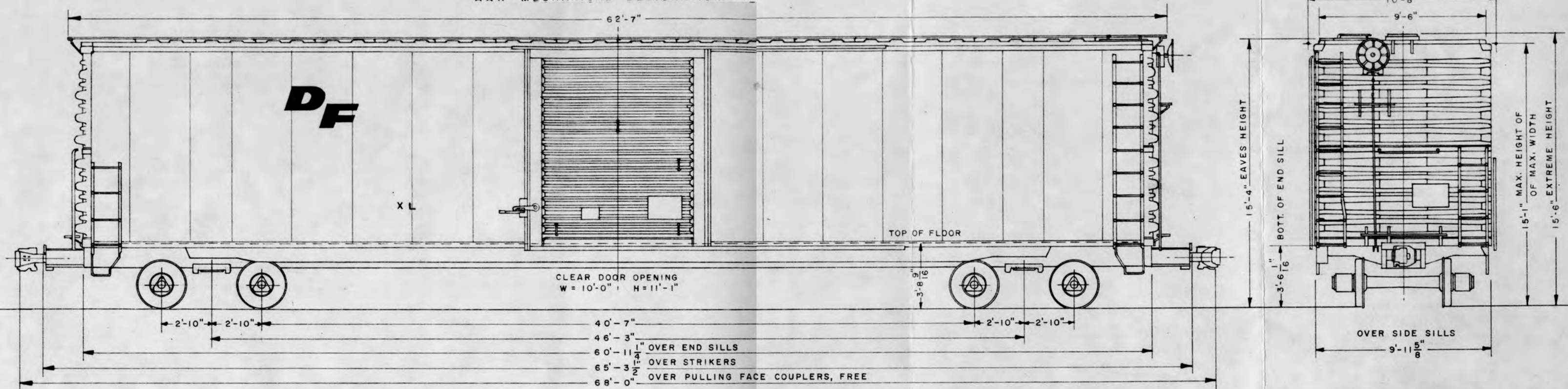

DESCRIPTION

GAUGE	4'-8 1/2"	ROOF	STANDARD RAILWAY EQUIPMENT CO. - DIAGONAL PANEL	MARKED CAPACITY, LBS.	137,000
JOURNALS	6" X 11" TIMKEN ROLLER BEARINGS	ENDS	STANDARD RAILWAY EQUIPMENT CO. 2-PIECE	LIGHT WEIGHT, LBS., AV.	82,200
WHEELS	33" WROT STEEL 1-W	SIDES	COPPER BEARING STEEL	MAXIMUM WEIGHT OF LADING, LBS., AV.	137,800
TRUCK TYPE	ASF A-3 RIDE CONTROL, 3 1/16" SPRING TRAVEL	FLOOR	1/8" PLATE OVER 2 3/8" T & G YELLOW PINE	CUBICAL CAPACITY, CU. FT.	6435
TRUCK SIDES	BARBER STABILIZED- NARROW PEDESTAL TYPE	UNDERFRAME	ACF FREIGHT-SAVER - 20" TRAVEL	LENGTH INSIDE	60'-8 5/8"
AXLES	D-6-D	DRAFT GEAR	CARDWELL-WESTINGHOUSE MARK 50	WIDTH INSIDE	9'-2 5/8"
SIDE BEARINGS	STUCKI SINGLE ROLLER	DOORS	CORRUGATED STEEL - YOUNGSTOWN TYPE FR-63	HEIGHT INSIDE	11'-6 3/16"
UNIT TYPE BRAKE BEAMS	ASF NO. 24	DOOR FIXTURES	CAMEL		
LOADER DEVICE	EVANS DF	COUPLER	AAR TYPE F SHANK - 6 7/16" X 8", TYPE E HEAD		
		BRAKE	ABD 1012		
		BRAKE SLACK ADJUSTER	ELLCON NATIONAL		
		HAND BRAKE	UNIVERSAL		
		RUNNING BOARDS, END PLATFORMS, BRAKE STEPS	APEX	YEAR BUILT	1966
				BUILDER	AMERICAN CAR & FOUNDRY CO.
BELT RAILS					
CROSSMEMBERS (DF-202154-1)					
SWINGBOARDS (DF 204920)					

DENVER & RIO GRANDE WESTERN R.R.
DF BOX CARS No's. 63888 to 63899

F-34

AAR MECHANICAL DESIGNATION = XML

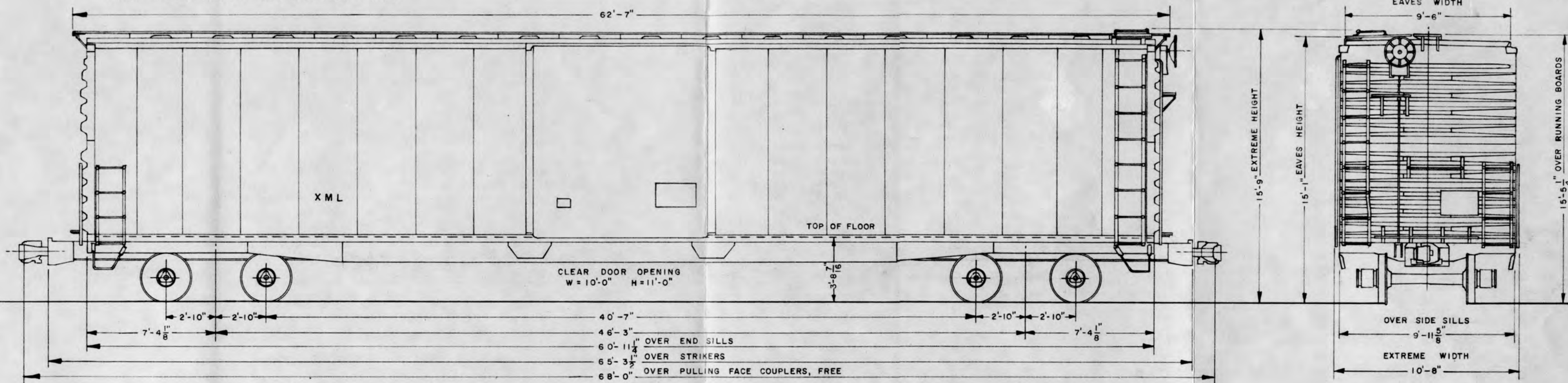

DESCRIPTION

GAUGE	4'-8 1/2"	ROOF	PULLMAN STANDARD-STEEL	MARKED CAPACITY, LBS.	140,000
JOURNALS	6" X 11" TIMKEN ROLLER BEARINGS	ENDS	PULLMAN STANDARD-CORRUGATED STEEL 2-PIECE	LIGHT WEIGHT, LBS., AV.	78,400
WHEELS	33" WROT STEEL 1-W	SIDES	STEEL	MAXIMUM WEIGHT OF LADING, LBS., AV.	141,600
AXLES	D-6-D	FLOOR	WOOD	CUBICAL CAPACITY, CU. FT.	6,516
TRUCK TYPE	ASF A-3 RIDE CONTROL, 3/16" SPRING TRAVEL	FLOOR COVERING	1/8" PERFORATED STEEL PLATE	LENGTH INSIDE	60'-8"
TRUCK SIDES	NARROW PEDESTAL TYPE	UNDERFRAME	HYDROFRAME 40-CUSHION-20" TRAVEL	WIDTH INSIDE - BETWEEN BELT RAILS	9'-2"
SIDE BEARINGS	STUCKI-ROLLER	DRAFT GEAR	CARDWELL-WESTINGHOUSE NY-II-F	HEIGHT INSIDE - AT EAVES	11'-4"
BRAKE BEAMS - UNIT TYPE	DAVIS NO. 18	DOORS	CAMEL SLIDING TYPE	HEIGHT INSIDE - AT CENTER	11'-4"
LOADER DEVICE	EVANS DF	DOOR FIXTURES	CAMEL	YEAR BUILT	1965
	<u>DF LOADER COMPLEMENT</u>	COUPLER	AAR 43" - TYPE F SHANK, TYPE E HEAD	BUILDER	PULLMAN STANDARD CAR MFG. CO.
BELT RAILS	22	BRAKE	AB 1012		
CROSSMEMBERS	80	BRAKE CYLINDER RELEASE VALVE	QRB		
DOORWAY BARS	24	BRAKE SLACK ADJUSTER	ELLCON NATIONAL		
SWINGBOARDS (PLASTIC) - 12"	50	HAND BRAKE	KLASING		
		RUNNING BOARDS, BRAKE STEP, CROSSOVER STEPS	APEX-STEEL		

DENVER & RIO GRANDE WESTERN R.R.
HY-CUBE BOX CARS No's. 63900 to 63924 & 63940 to 63949

AAR MECHANICAL DESIGNATION = XML

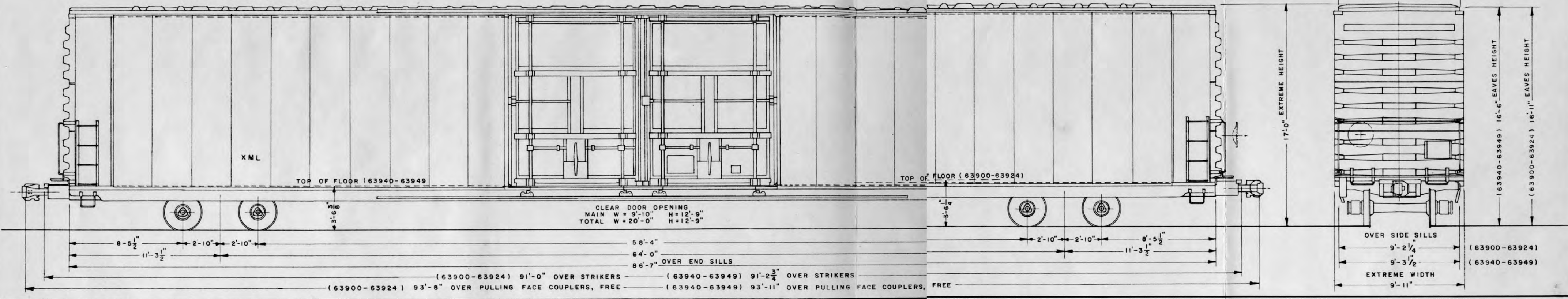

DESCRIPTION

<p>— LOADER COMPLEMENT — 63900-63924</p> <p>BELT RAILS (WESTERN RAILWAY EQUIPMENT CO.) 12 BELT RAILS (EVANS DF-2) 8 MOVABLE BULKHEADS (63900-63912-EVANS) 2 MOVABLE BULKHEADS (63913-63924-EQUIPCO) 2</p>	<p>GAUGE 4'-8 1/2" JOURNAL 6" X 11" TIMKEN ROLLER BEARINGS WHEELS 33" WROT STEEL 1-W AXLES D-II-65 TRUCK TYPE BARBER S-2A RIDE CONTROL, 2 1/2" SPRING TRAVEL TRUCK SIDES NARROW PEDESTAL TYPE SIDE BEARINGS (63900-63924) DREWS - TYPE R SIDE BEARINGS (63940-63949) STUCKI-SINGLE ROLLER BRAKE BEAMS WABCO PAC B-3 BRAKE SHOES (63900-63924) COBRA V-141 BRAKE SHOES (63940-63949) COMPOSITION</p>	<p>ROOF STANDARD RAILWAY EQUIPMENT CO. - DIAGONAL PANEL ENDS STANDARD RAILWAY EQUIPMENT CO. - IMPROVED DREADNAUGHT 3-PIECE SIDES STEEL FLOOR (63900-63924) 3/16" STEEL PLATE FLOOR (63940-63949) 1/4" STEEL PLATE UNDERFRAME KEYSTONE CUSHION-20" TRAVEL DRAFT GEAR (63900-63924) CARDWELL-WESTINGHOUSE NY-11-F DRAFT GEAR (63940-63949) MINER-FRICTION TYPE DOORS CAMEL-SINGLE SHEATHED-PLUG TYPE DOOR FIXTURES CAMEL COUPLER AAR TYPE F SHANK-6 7/16" X 8" X 60", TYPE E HEAD BRAKE (63900-63924) WABCO PAC-7 1/2" DIA. CYL., NO. 8 VENT VALVE-AB BRAKE (63940-63949) WABCO PAC-7 1/2" DIA. CYL., A-1 REDUCTION RELAY VALVE WITH NO. 8 VENT VALVE BRAKE CYLINDER RELEAASE VALVE (63900-63924) QRB HAND BRAKE (63900-63924) MINER HAND BRAKE (63940-63949) AJAX CROSSOVER STEPS (63900-63924) APEX CROSSOVER STEPS (63940-63949) MORTON</p>	<p>MARKED CAPACITY, LBS. 100,000 LIGHT WEIGHT, LBS., AV. (63900-63924) 110,000 MAXIMUM WEIGHT OF LADING, LBS., AV. (63900-63924) 110,000 LIGHT WEIGHT, LBS., AV. (63940-63949) 112,800 MAXIMUM WEIGHT OF LADING, LBS., AV. (63940-63949) 107,200 CUBICAL CAPACITY, CU. FT. 10,000 LENGTH INSIDE 86'-6" WIDTH INSIDE 9'-2" HEIGHT INSIDE, AT EAVES 12'-9" HEIGHT INSIDE, AT CENTER 13'-3"</p> <p>YEAR BUILT (63900-63924) 1964 YEAR BUILT (63940-63949) 1966 BUILDERS THRALL CAR MFG. CO.</p>
<p>63940-63949</p> <p>BELT RAILS (EVANS DF-2) 5 MOVABLE BULKHEADS (PRECO) 2</p>			

DENVER & RIO GRANDE WESTERN R.R.
HY-CUBE BOX CARS No's. 63950 to 63956

AAR MECHANICAL DESIGNATION = XP

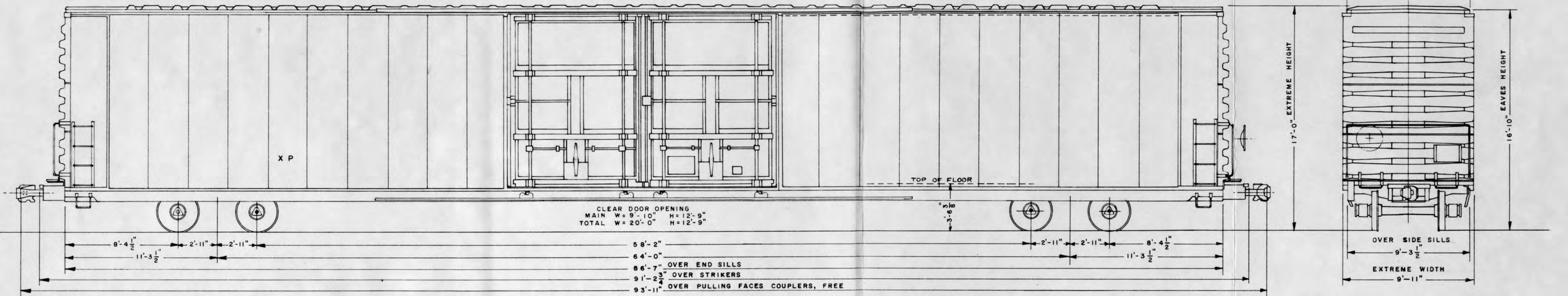

DESCRIPTION

LOADER COMPLEMENT	
RUB RAILS (EVANS DF-2)	5
MOVABLE BULKHEADS (EQUIPCO)	2
RACKS-PER CAR (FORD-TYPE ZE-II)	72

GAUGE	4'-8 1/2"
JOURNALS	6 1/2" X 12" TIMKEN ROLLER BEARINGS
WHEELS	(H-36) 36" WROT STEEL 1-W
AXLES	D-II-65
TRUCK TYPE	BARBER S-2A RIDE CONTROL, 2 1/2" SPRING TRAVEL
TRUCK SIDES	NARROW PEDESTAL TYPE
SIDE BEARINGS	STUCKI-DOUBLE ROLLER
BRAKE BEAMS	NYCOPAC
BRAKE SHOES	COMPOSITION

ROOF	STANDARD RAILWAY EQUIPMENT CO.-DIAGONAL PANEL
ENDS	STANDARD RAILWAY EQUIPMENT CO.-IMPROVED DREADNAUGHT 3-PIECE
SIDES	SINGLE SHEATHED COPPER BEARING STEEL
FLOOR	TRI-TEN 1/4" STEEL PLATE
DOORS	4 PER CAR YOUNGSTOWN-ALUMINUM PLUG-SLIDING TYPE
DOOR FIXTURES	CAMEL
UNDERFRAME	KEYSTONE CUSHION-20" TRAVEL
DRAFT GEAR	CARDWELL-WESTINGHOUSE MARK 50
COUPLER	AAR TYPE F SHANK-6 7/16 X 8" X 60", TYPE E HEAD
BRAKE	NYCOPAC 8 1/2" CYL., A-1 REDUCTION RELAY VALVE WITH NO. 8 VENT VALVE
HAND BRAKE	MINER
CROSSOVER STEPS	MORTON

MARKED CAPACITY, LBS.	142,000
LIGHT WEIGHT, LBS., AV.	119,400
MAXIMUM WEIGHT OF LADING, LBS., AV.	143,600
CUBICAL CAPACITY, CU. FT.	10,000
LENGTH INSIDE	86'-6"
WIDTH INSIDE	9'-2"
HEIGHT INSIDE, AT EAVES	12'-9"
HEIGHT INSIDE, AT CENTER	13'-3"
YEAR BUILT	1967
BUILDER	THRALL CAR MFG. CO.

DENVER & RIO GRANDE WESTERN R.R.
HY-CUBE BOX CARS No's. 63957 to 63960

AAR MECHANICAL DESIGNATION = XP
THESE CARS EXCEED PLATE "C"

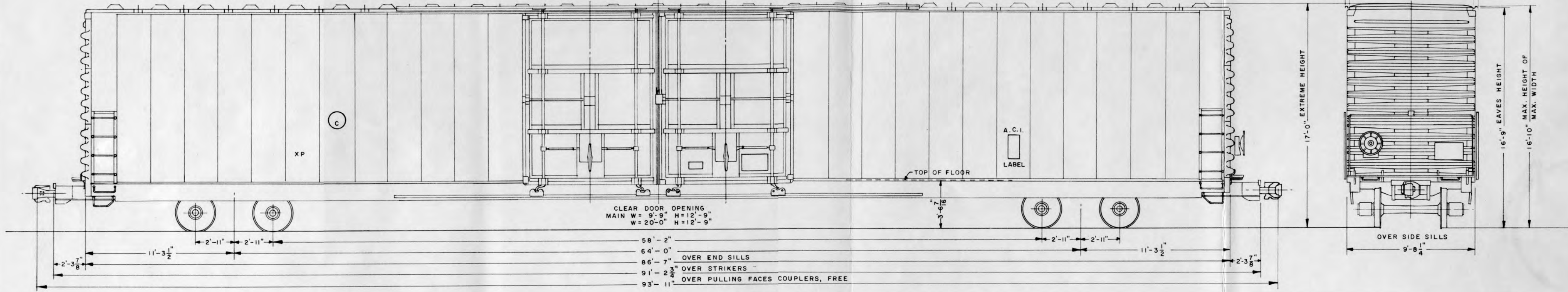

CLEAR DOOR OPENING
MAIN W = 9'-9" H = 12'-9"
W = 20'-0" H = 12'-9"

- 58'-2" _____
- 64'-0" _____
- 86'-7" OVER END SILLS
- 91'-2 3/4" OVER STRIKERS
- 93'-11" OVER PULLING FACES COUPLERS, FREE

DESCRIPTION

— LOADER COMPLIMENT —

RUB RAILS	5
WHEEL RACKS	13
BUMPER RACKS	31

GAUGE	4'-8 1/2"
JOURNALS	BRENCO 6 1/2" X 12" ROLLER BEARINGS
WHEELS	36" CAST STEEL 1-W
AXLES	D-11-67
TRUCK TYPE	BARBER S-2A RIDE CONTROL, 3 11/16" SPRING TRAVEL
TRUCK SIDES	NARROW PEDESTAL TYPE
SIDE BEARINGS	STUCKI - DOUBLE ROLLER
BRAKE SHOES	

ROOF	PULLMAN STANDARD - GALVANIZED STEEL
ENDS	PULLMAN STANDARD - CORRUGATED STEEL 3-PIECE
SIDES	26-0.10" STEEL SHEETS EACH SIDE
FLOOR	1/4" STEEL PLATE
UNDERFRAME	HYDRAFRAME 40-CUSHION - 20" TRAVEL
DRAFT GEAR	NATIONAL MALLEABLE TYPE NC-440-1
DOORS	YOUNGSTOWN SINGLE SHEATHED ALUMINUM - PLUG TYPE
DOOR FIXTURES	CAMEL
COUPLER	TYPE E HEAD
BRAKE	NYCOPAK - A-1 REDUCTION RELAY VALVE - ABD 1210
HAND BRAKE	MINER - MODEL NO. 6600-L
CROSSOVER STEPS	APEX - GALVANIZED STEEL

MARKED CAPACITY, LBS.	144,000
LIGHT WEIGHT, LBS., AV.	116,600
MAXIMUM WEIGHT OF LADING, LBS., AV.	146,400
CUBICAL CAPACITY, CU. FT.	10,000
LENGTH INSIDE	86'-6"
WIDTH INSIDE - BETWEEN RUB RAILS	9'-2"
HEIGHT INSIDE - AT EAVES	12'-9"
HEIGHT INSIDE - AT CENTER	13'-2"
YEAR BUILT	1967
BUILDER	PULLMAN STANDARD CAR MFG. CO.

DENVER & RIO GRANDE WESTERN R.R.
HY-CUBE BOX CARS No's. 63961 to 63990

AAR MECHANICAL DESIGNATION = XP

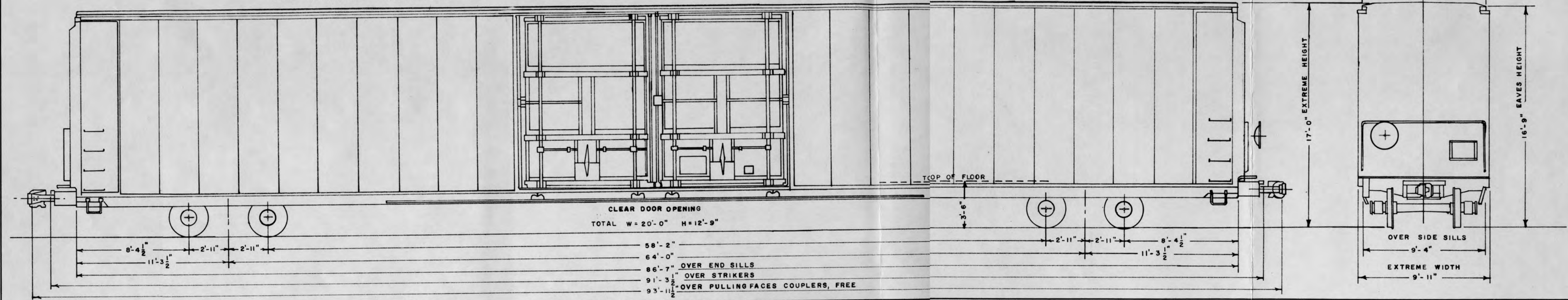

DESCRIPTION

<p>LOADER COMPLEMENT</p> <p>RUB RAILS (EVANS DF-2) ----- 5</p> <p>MOVABLE BULKHEADS (EVANS) ----- 2</p>	<p>GAUGE ----- 4'-8 1/2"</p> <p>JOURNALS ----- 6 1/2" x 12" TIMKEN, HYATT R.B.</p> <p>WHEELS ----- 36" WROT STEEL 1-W</p> <p>AXLES ----- D-11-68</p> <p>TRUCK TYPE ----- BARBER S-2-C RIDE CONTROL, 3 1/16" SPRING TRAVEL</p> <p>TRUCK SIDES ----- NARROW PEDESTAL TYPE</p> <p>SIDE BEARINGS ----- STUCKI - DOUBLE ROLLER</p>	<p>ROOF ----- STANDARD RAILWAY EQUIPMENT</p> <p>ENDS ----- STANDARD RAILWAY EQUIPMENT</p> <p>SIDES ----- STEEL</p> <p>FLOOR ----- 1/4" STEEL PLATE</p> <p>DOORS-4 PER CAR ----- YOUNGSTOWN ALUMINUM PLUG-SLIDING TYPE</p> <p>UNDERFRAME ----- KEYSTONE CUSHION 20" TRAVEL</p> <p>DRAFT GEAR ----- MINER</p> <p>COUPLER ----- TYPE F SHANK 60" TYPE E HEAD</p> <p>BRAKE ----- WABCO PAC 8 1/2" CYL., A-1 REDUCTION RELAY VALVE</p> <p>HAND BRAKE ----- ELLCON NATIONAL</p>	<p>MARKED CAPACITY, LBS. ----- 142,000</p> <p>LIGHT WEIGHT, LBS., AV. ----- 119,400</p> <p>MAXIMUM WEIGHT OF LADING, LBS., AV. ----- 143,600</p> <p>CUBICAL CAPACITY, CU. FT. ----- 10,000</p> <p>LENGTH INSIDE ----- 86'-6"</p> <p>WIDTH INSIDE ----- 9'-2"</p> <p>HEIGHT INSIDE ----- 12'-9"</p> <p>YEAR BUILT ----- 1969</p> <p>BUILDER ----- GREENVILLE STEEL CAR COMPANY</p>
---	---	--	--

DENVER & RIO GRANDE WESTERN R.R.
HY-CUBE BOX CARS No's. 63925 to 63939

AAR MECHANICAL DESIGNATION = XML

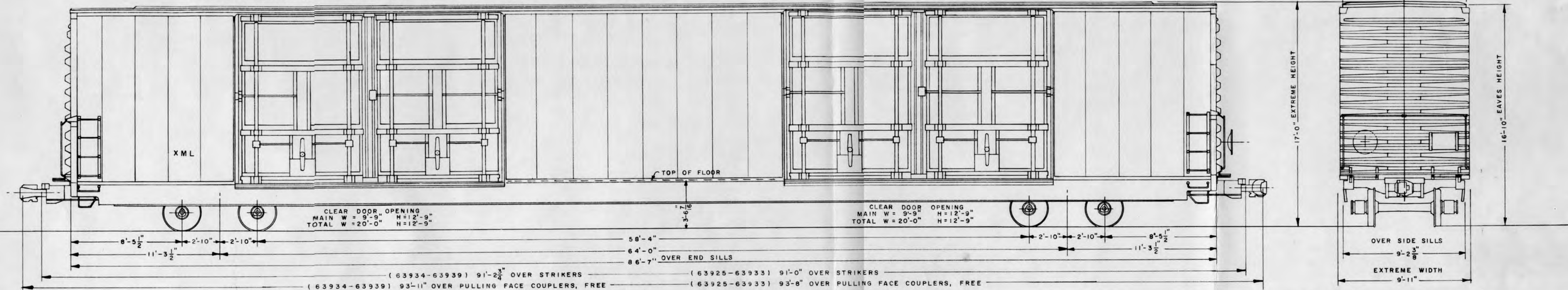

DESCRIPTION

<p>— LOADER COMPLEMENT — 63934 - 63939</p> <ul style="list-style-type: none"> RUB RAILS (EVANS DF-2) ----- 5 SLIDING BULKHEADS (EQUIPCO) ----- 2 FRONT RACKS (DMH-1728) ----- 6 FRONT FENDER RACKS (CMH-1603) ----- 12 REAR FENDER RACKS (CMH-1604) ----- 4 GRILLE FILLER PANEL RACKS (CMH-1605) ----- 16 HOOD RACKS (CMH-1548) ----- 16 END GATE RACKS (DMH-1728) ----- 15 PUB SIDE RACKS (DMH-1725) ----- 9 CL SIDE RACKS (DMH-1726) ----- 30 	<p>GAUGE ----- 4'-8 1/2"</p> <p>JOURNALS (63925-63933) ----- 6" x 11" HYATT ROLLER BEARINGS</p> <p>JOURNALS (63934-63939) ----- 6" x 11" TIMKEN ROLLER BEARINGS</p> <p>WHEELS ----- 33" WROT STEEL I-W</p> <p>AXLES ----- D-11-65</p> <p>TRUCK TYPE ----- ASF A-3 RIDE CONTROL, 2 1/2" SPRING TRAVEL</p> <p>TRUCK SIDES ----- NARROW PEDESTAL TYPE</p> <p>SIDE BEARINGS ----- STUCKI-SINGLE ROLLER</p> <p>BRAKE BEAMS ----- WABCOPAC B3</p> <p>BRAKE SHOES ----- COBRA V-141</p>	<p>ROOF ----- PULLMAN STANDARD-STEEL</p> <p>ENDS ----- PULLMAN STANDARD-CORRUGATED STEEL 3-PIECE</p> <p>SIDES ----- STEEL</p> <p>FLOOR ----- 1/4" STEEL PLATE</p> <p>UNDERFRAME ----- HYDROFRAME 40-CUSHION-20" TRAVEL</p> <p>DRAFT GEAR (63925-63933) ----- CARDWELL-WESTINGHOUSE NY-II-F</p> <p>DRAFT GEAR (63934-63939) ----- MINER-FRICTION TYPE</p> <p>DOORS ----- CAMEL-8 TEN FEET WIDE-SINGLE SHEATHED-PLUG TYPE</p> <p>DOOR FIXTURES ----- CAMEL</p> <p>COUPLER ----- AAR TYPE F SHANK-6 7/16" x 8" x 60", TYPE E HEAD</p> <p>BRAKE ----- WABCOPAC-7 1/2 CYL., A-1 REDUCTION RELAY VALVE, NO.8 VENT VALVE-ABD</p>	<p>MARKED CAPACITY, LBS. (63925-63933) ----- 117,000</p> <p>LIGHT WEIGHT, LBS., AV. (63925-63933) ----- 102,800</p> <p>MAXIMUM WEIGHT OF LADING, LBS., AV. (63925-63933) ----- 117,200</p> <p>MARKED CAPACITY, LBS. (63934-63939) ----- 99,000</p> <p>LIGHT WEIGHT, LBS., AV. (63934-63939) ----- 120,500</p> <p>MAXIMUM WEIGHT OF LADING, LBS., AV. (63934-63939) ----- 99,500</p> <p>LENGTH INSIDE ----- 86'-6"</p> <p>WIDTH INSIDE - BETWEEN RUB RAILS ----- 9'-2"</p> <p>HEIGHT INSIDE - AT EAVES ----- 12'-9"</p> <p>HEIGHT INSIDE - AT CENTER ----- 13'-2"</p> <p>CUBICAL CAPACITY ----- 10,000</p>
<p>63925 - 63933</p> <ul style="list-style-type: none"> RUB RAILS (EVANS DF-2) ----- 5 SLIDING BULKHEADS (EQUIPCO) ----- 2 FRONT FENDER RACKS (CMH-1603) ----- 20 REAR FENDER RACKS (CMH-1604) ----- 36 GRILLE FILLER PANEL RACKS (CMH-1605) ----- 8 		<p>HAND BRAKE (63925-63933) ----- MINER</p> <p>HAND BRAKE (63934-63939) ----- ELLCON NATIONAL</p> <p>CROSSOVER STEPS ----- GALVANIZED STEEL</p>	<p>YEAR BUILT (63925-63933) ----- 1964 & 1965</p> <p>YEAR BUILT (63934-63939) ----- 1966</p> <p>BUILDERS ----- PULLMAN STANDARD CAR MFG. CO.</p>

REISSUE
 JAN. 2, 1957.
 JULY 1, 1957.
 SEPT. 1, 1959.
 JAN. 2, 1963.

DENVER & RIO GRANDE WESTERN R. R.
 BOX CARS No's. 64000 to 64099
 AAR MECHANICAL DESIGNATION = XM

F-37

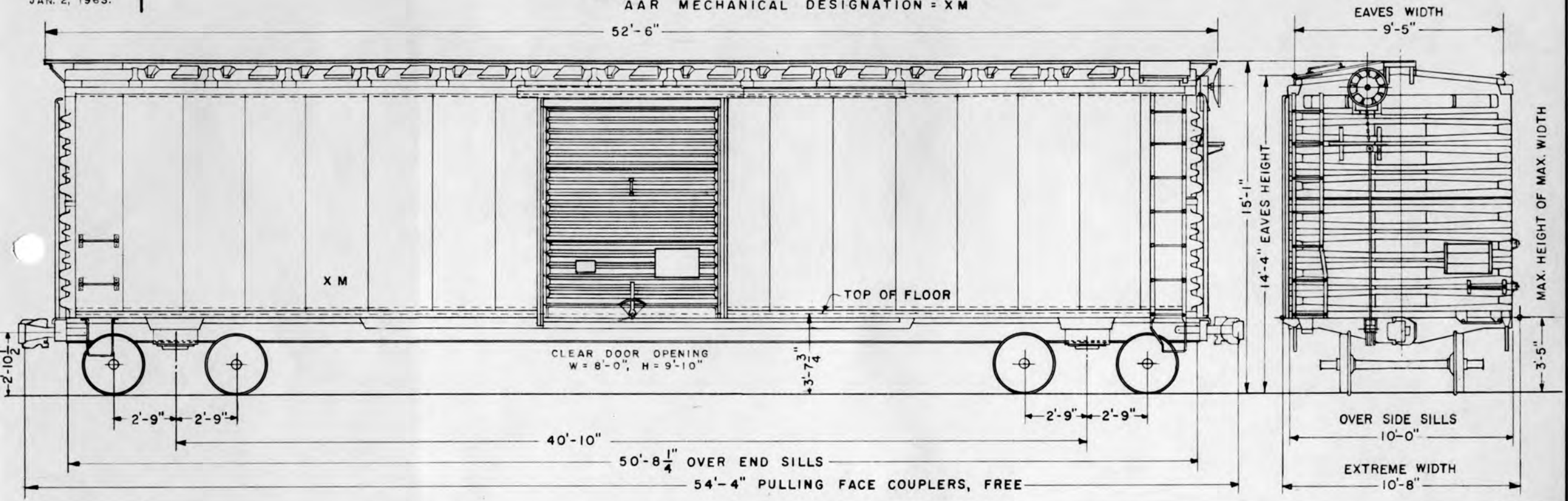

DESCRIPTION

GAUGE ----- 4'-8 ¹ / ₂ "	ROOF ----- STANDARD RY. EQUIPT. CO. DIAGONAL PANEL-STEEL	MARKED CAPACITY, LBS. ----- 110,000
JOURNALS ----- 5 ¹ / ₂ " X 10"	ENDS ----- STANDARD RY. EQUIPT. CO. DREADNAUGHT 2-PIECE	LIGHT WEIGHT, LBS., AV. ----- 53,200
WHEELS ----- 33" ROLLED STEEL I.W.	SIDES ----- STEEL-WOOD LINING	MAX. WEIGHT OF LADING, LBS. ----- 123,800
TRUCK TYPE ----- ASF A-3 RIDE CONTROL, SPRING PLANKLESS 3 ¹ / ₁₆ " SPRING TRAVEL	FLOOR ----- GREAT LAKES STEEL CO.-NAILABLE STEEL	CUBICAL CAPACITY, CU. FT. ----- 49,520
TRUCK SIDES ----- CAST STEEL-INTEGRAL BOXES	UNDERFRAME ----- STEEL	LENGTH INSIDE ----- 50'-6"
TRUCK BOLSTER ----- CAST STEEL	DOORS ----- CAMEL CORRUGATED STEEL-TYPE 47	WIDTH INSIDE ----- 9'-4"
SIDE BEARINGS ----- STUCKI ROLLER	DOOR FIXTURES ----- CAMEL ROLLER LIFT	HEIGHT INSIDE, AT EAVES ----- 10'-6"
UNIT TYPE BRAKE BEAMS NO. 18 ----- CRECO	DRAFT GEAR ----- CARDWELL-WESTINGHOUSE NY-II-F	HEIGHT INSIDE, AT CENTER ----- 11'-0"
	COUPLER ----- AAR TYPE E	
	BRAKE ----- AB 1012	NO'S. 64021, 64024, 64034, 64040, 64041, 64048, 64088 SHOWN AS STANCHION CARS ON PAGE F-39
	HAND BRAKE ----- MINER	NO'S. 64005, 64006, 64016, 64045, 64047, 64052, 64067, 64083, 64096, 64097 SHOWN ON PAGE F-38 AS DF CARS.
	BRAKE GEAR REGULATOR ----- ROYAL TYPE F	YEAR BUILT ----- 1956
	RUNNING BOARDS ----- U.S. GYPSUM CO.-STEEL	BUILDERS ----- AMERICAN CAR & FOUNDRY CO.

DENVER & RIO GRANDE WESTERN R.R.

DF BOX CARS No's. 64005, 64006, 64016, 64045, 64047, 64052, 64067
 64083, 64096, 64097

AAR MECHANICAL DESIGNATION = XML

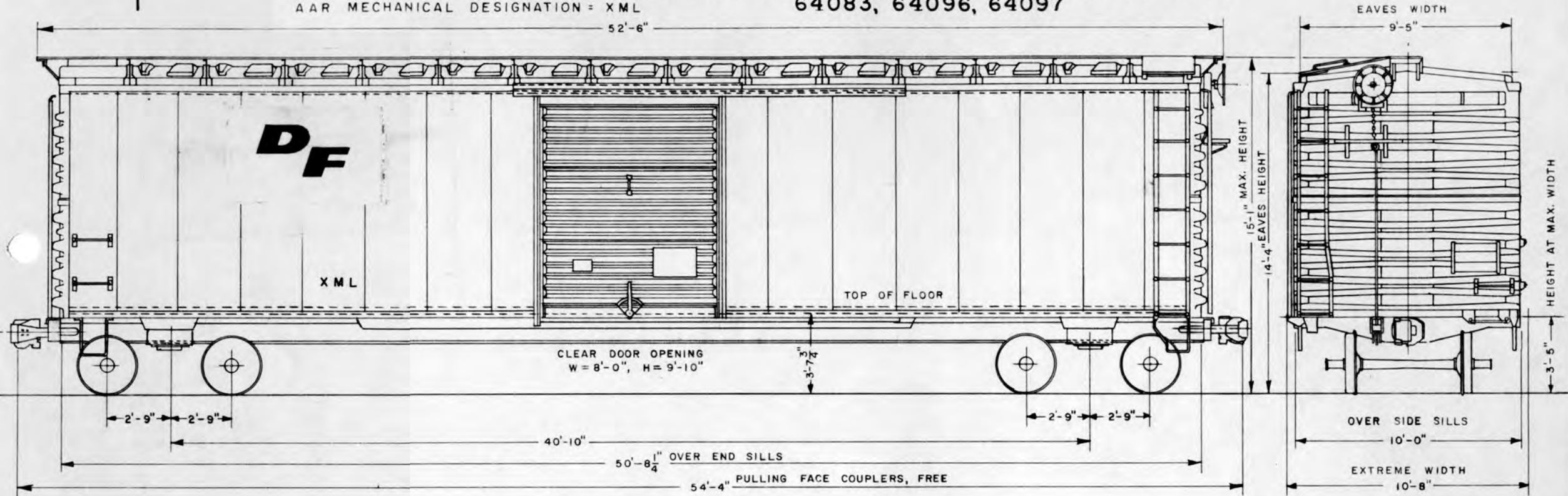

DESCRIPTION

GAUGE ----- 4'-8 $\frac{1}{2}$ "	ROOF -- STANDARD RY. EQUIP. CO. DIAGONAL PANEL-STEEL	MARKED CAPACITY, LBS. ----- 110,000
JOURNALS ----- 5 $\frac{1}{2}$ " X 10"	ENDS -- STANDARD RY. EQUIP. CO DREADNAUGHT 2-PIECE	LIGHT WEIGHT, LBS., AV. ----- 58,500
WHEELS ----- 33" ROLLED STEEL- 1-W	SIDES ----- STEEL-WOOD LINING	MAX. WEIGHT OF LADING, LBS., AV. ----- 118,500
TRUCK TYPE -- { ASF A-3 RIDE CONTROL, SPRING PLANKLESS 3 $\frac{1}{16}$ " SPRING TRAVEL	UNDERFRAME ----- STEEL	CUBICAL CAPACITY, CU. FT. ----- 4861
TRUCK SIDES ----- CAST STEEL- INTEGRAL BOXES	FLOOR ----- GREAT LAKES STEEL CO.-NAILABLE STEEL	LENGTH INSIDE ----- 50'-6"
TRUCK BOLSTER ----- CAST STEEL	DOORS ----- CAMEL CORRUGATED STEEL- TYPE 47	WIDTH INSIDE ----- 9'-2"
SIDE BEARINGS ----- ROLLER TYPE-STUCKI	DOOR FIXTURES ----- CAMEL ROLLER LIFT	HEIGHT INSIDE, AT EAVES ----- 10'-6"
UNIT TYPE BRAKE BEAMS-NO. 18 ----- CRECO	DRAFT GEAR ----- CARDWELL-WESTINGHOUSE NY-II-F	HEIGHT INSIDE, AT CENTER ----- 11'-0"
LOADER DEVICE ----- DF	COUPLER ----- AAR TYPE E	
----- DF COMPLEMENT -----	BRAKE ----- AB 1012	
	HAND BRAKE ----- MINER	
BELT RAILS ----- 8		
CROSSMEMBERS ----- 25	BRAKE SLACK ADJUSTER ----- ROYAL TYPE F	
DOORWAY MEMBERS ----- 8		
DECK BOARDS -INTERLOCKING (48" X 106") ----- 16	RUNNING BOARDS ----- U.S. GYPSUM CO.- STEEL	YEAR BUILT ----- 1956
		BUILDERS ----- AMERICAN CAR & FOUNDRY CO.
		DF LOADERS APPLIED ----- 1959

DENVER & RIO GRANDE WESTERN R.R.
SEL BOX CARS No's. 64061 & 64084

F-40

AAR MECHANICAL DESIGNATION = XL

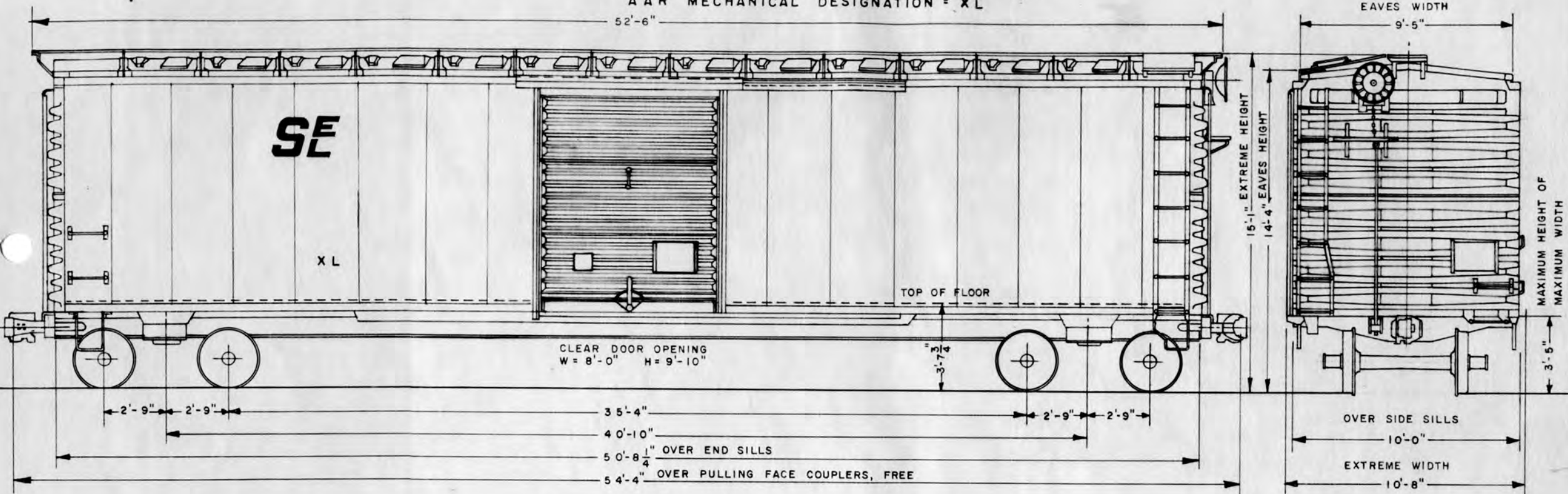

DESCRIPTION

GAUGE ----- 4'-8 1/2"
JOURNALS ----- 5 1/2" X 10"
WHEELS ----- 33" WROT STEEL 1-W
TRUCK TYPE-ASF A-3 RIDE CONTROL, SPRING PLANKLESS,
SPRING TRAVEL ----- 3 1/16"
TRUCK SIDES ----- CAST STEEL-INTEGRAL BOXES
SIDE BEARINGS ----- STUCKI ROLLER
UNIT TYPE BRAKE BEAMS ----- CRECO-NO. 18
LOADER DEVICE ----- SPARTAN EASY LOADER

- SEL LOADER CCMPLEMENT -

BELT RAILS ----- 9
CROSSMEMBERS (ALUMINUM) ----- 40
DOORWAY MEMBERS ----- 10
DECKBOARDS (48" X 108") ----- 18

ROOF ----- STANDARD RY. EQUIPT. CO.-DIAGONAL PANEL-STEEL
ENDS ----- STANDARD RY. EQUIPT. CO.-DREADNAUGHT-2-PIECE
SIDES ----- STEEL
FLOOR ----- GREAT LAKES STEEL CO.-NAILABLE STEEL
UNDERFRAME ----- STEEL
DOORS ----- CAMEL-CORRUGATED STEEL-TYPE 47
DOOR FIXTURES ----- CAMEL ROLLER LIFT
DRAFT GEAR ----- CARDWELL-WESTINGHOUSE NY-II-F
COUPLER ----- AAR TYPE E
BRAKE ----- AB 1012
HAND BRAKE ----- MINER

BRAKE SLACK ADJUSTER ----- ROYAL TYPE F

RUNNING BOARDS ----- U.S. GYPSUM CO.-STEEL

MARKED CAPACITY, LBS. ----- 110,000
LIGHT WT., LBS. (64061) ----- 57,300
LIGHT WT., LBS. (64084) ----- 57,300
MAX. WT. OF LADING, LBS. (64061) ----- 119,700
MAX. WT. OF LADING, LBS. (64064) ----- 119,700

CUBICAL CAPACITY, CU. FT. ----- 4938
LENGTH INSIDE ----- 50'-6"
WIDTH INSIDE ----- 9'-3 3/4"
HEIGHT INSIDE, AT EAVES ----- 10'-6"
HEIGHT INSIDE, AT CENTER ----- 11'-0"

YEAR BUILT ----- 1956
BUILDERS ----- AMERICAN CAR & FOUNDRY CO.
SEL EQUIPMENT APPLIED ----- 1963

DENVER & RIO GRANDE WESTERN R.R.
 DF BOX CARS No's. 65200 TO 65299
 AAR MECHANICAL DESIGNATION = XL

F-46

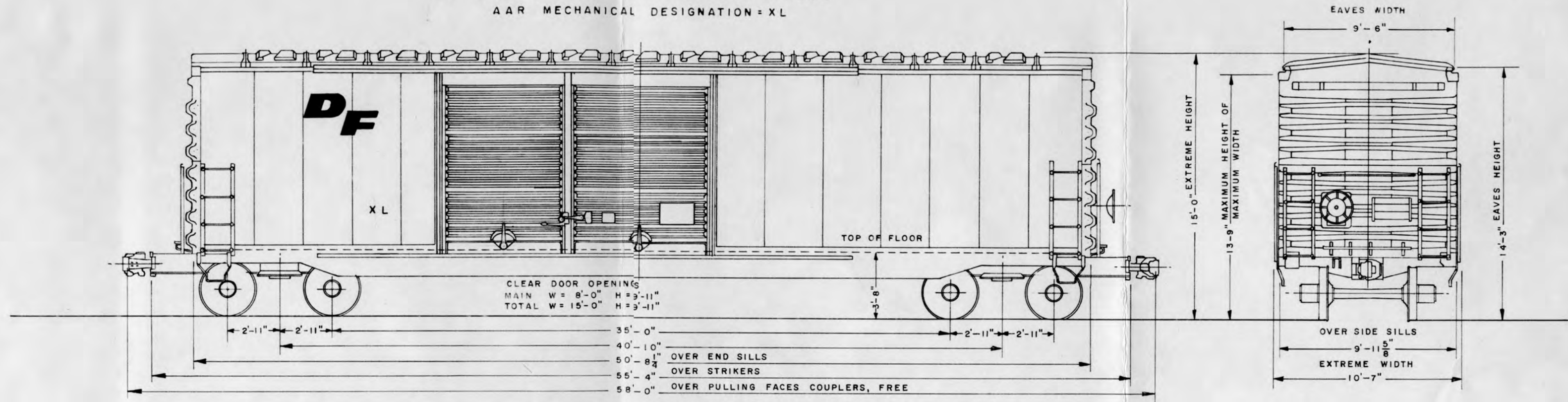

DESCRIPTION

DF LOADER COMPLEMENT

BELT RAILS - DF-2	7
CROSSMEMBERS - ALUMINUM	14
DOORWAY BARS	8
DECKBOARDS (24" X 105")	10
DECKBOARDS (48" X 105")	10

GAUGE	4'-8 1/2"
JOURNALS	6 1/2 X 12" TIMKEN ROLLER BEARINGS
WHEELS	(J-36) 36" WROT STEEL 2-W
AXLES	D-11-67
TRUCK TYPE	ASF A-3 RIDE CONTROL, 3 11/16" SPRING TRAVEL
TRUCK SIDES	NARROW PEDESTAL TYPE
SIDE BEARINGS	STUCKI DOUBLE ROLLER
BRAKE BEAMS	WABCOPAC B-3
BRAKE SHOES	COBRA V-141
LOADER DEVICE	EVANS DF-2

ROOF	STANDARD RAILWAY EQUIPMENT CO.-DIAGONAL PANEL
ENDS	STANDARD RAILWAY EQUIPMENT CO.-CORRUGATED STEEL 2-PIECE
END LINING	RAILHEAD CORP. 3-PIECE CORRUGATED STEEL
SIDES	COPPER BEARING STEEL - WOOD LINING
FLOOR	NATIONAL STEEL CORP. 1 3/4" NAILABLE STEEL-TYPE EPR-120
DOORS	YOUNGSTOWN TYPE 47
DOOR FIXTURES	YOUNGSTOWN
UNDERFRAME	KEYSTONE-20" TRAVEL
DRAFT GEAR	CARDWELL-WESTINGHOUSE - MARK 50
COUPLER	6 1/4" X 8" X 25" SHANK - AAR TYPE E
BRAKE	WABCOPAC B-3, 8 1/2" DIA. CYLINDER - ABD
HAND BRAKE	ELLCON NATIONAL - MODEL 1600-2
CROSSOVER STEPS	APEX TYPE A-1

MARKED CAPACITY, LBS.	184,000
LIGHT WEIGHT, LBS., AV.	77,200
MAXIMUM WEIGHT OF LADING, LBS., AV.	185,800
CUBICAL CAPACITY, CU. FT.	4960
LENGTH INSIDE	50'-6"
WIDTH INSIDE	9'-4"
HEIGHT INSIDE	10'-6"
YEAR BUILT	1967
BUILDER	GENERAL AMERICAN TRANSPORTATION CORP.

DENVER & RIO GRANDE WESTERN R.R.
SEL BOX CARS No's. 67400 to 67419
AAR MECHANICAL DESIGNATION = XL

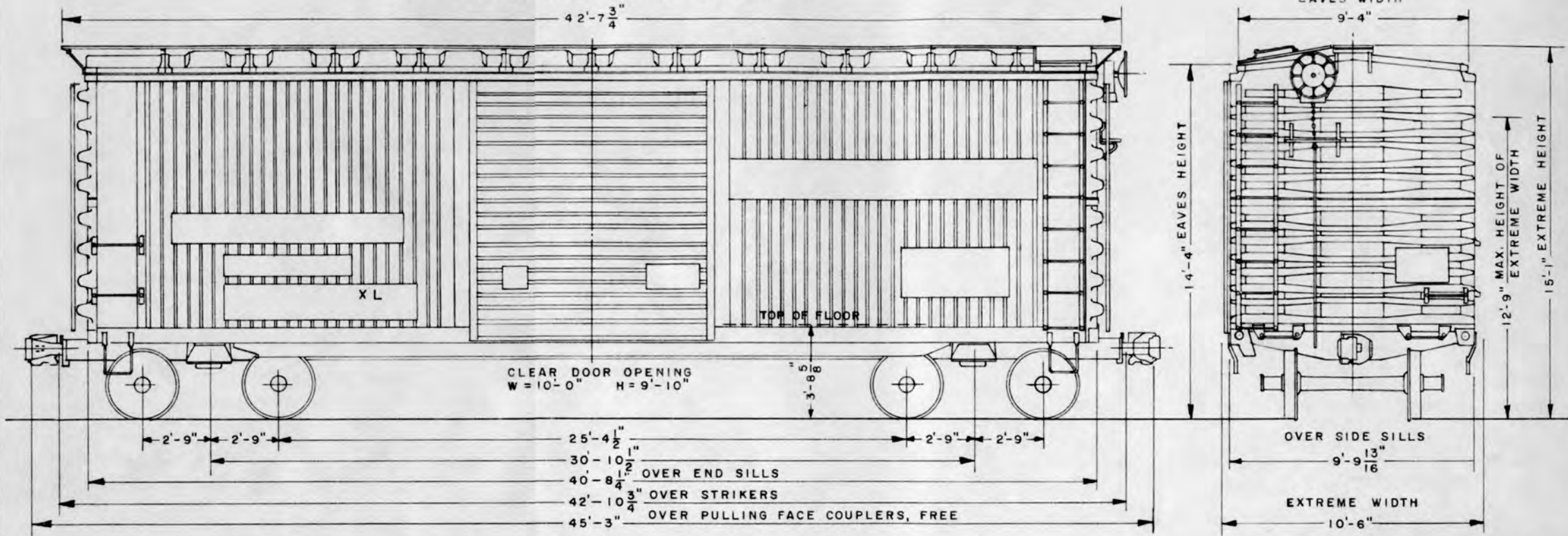

DESCRIPTION

GAUGE	4'-8 1/2"
JOURNALS	5 1/2" X 10"
WHEELS	33" WROT STEEL 1-W
TRUCK TYPE	ASF A-3 RIDE CONTROL
TRUCK SIDES	CAST STEEL- INTEGRAL BOXES
SPRING TRAVEL	3 11/16"
SIDE BEARINGS	STUCKI

ROOF	MURPHY IMPROVED- SOLID STEEL
ENDS	IMPROVED DREADNAUGHT 2-PIECE
SIDES	TRANSCO TRI-RIB STEEL
FLOOR	TRANSCO TRI-RIB NAILABLE STEEL
UNDERFRAME	DURYEA
DOORS	CAMEL- SLIDING TYPE
DOOR FIXTURES	CAMEL
DRAFT GEAR	DURYEA
COUPLER	6 1/4" X 8" SHANK, AAR TYPE 'E
BRAKE	AB 1012
HAND BRAKE	NO'S. 67400, 67404, 67405, 67408, 67409, 67410, 67414, 67417 HAVE AJAX. THE REST HAVE UNIVERSAL.
BRAKE SLACK ADJUSTER	ROYAL TYPE F
RUNNING BOARDS	NO'S. 67400, 67404, 67405, 67408, 67409, 67410, 67414, 67417 HAVE APEX. THE REST HAVE GYPSUM.

MARKED CAPACITY, LBS.	110,000
LT. WT., LBS., AV. (67403, 67405, 67416, 67418)	51,900
LIGHT WEIGHT, LBS., AV. (OTHERS)	52,100
MAX. WT. LADING, LBS., AV. (67403, 67405, 67416, 67418)	125,100
MAXIMUM WEIGHT OF LADING, LBS., AV. (OTHERS)	124,900

CUBICAL CAPACITY, CU. FT.	3959
LENGTH INSIDE	40'-6"
WIDTH INSIDE	9'-4"
HEIGHT INSIDE	10'-6"

— TRANSCO SEL LOADER COMPLEMENT —

67403, 67405, 67416, 67418	67400-67402, 67404, 67406 67407-67417, 67419
BELT RAILS	15
CROSSMEMBERS	24
DOORWAY MEMBERS	12
DECKBOARDS (33" X 107")	8
DECKBOARDS (52" X 107")	4
SIDESWAY BRACKETS	14
BELT RAILS	15
CROSSMEMBERS	20
DOORWAY MEMBERS	8
DECKBOARDS (54" X 108")	8

67400	FORMERLY 67721	67410	FORMERLY 67526
67401	" 67870	67411	" 67991
67402	" 67820	67412	" 67757
67403	" 67972	67413	" 67878
67404	" 67712	67414	" 67666
67405	" 67561	67415	" 67769
67406	" 67876	67416	" 67816
67407	" 67947	67417	" 67599
67408	" 67587	67418	" 67919
67409	" 67729	67419	" 67921

YEAR BUILT AS XM BOX CARS 1946
 BUILDER PRESSED STEEL CAR CO.
 ASSIGNED TO SPECIAL SERVICE 1966
 SIDES, FLOORS, LOADERS APPLIED BY TRANSCO

DENVER & RIO GRANDE WESTERN R.R.
 LOADER EQUIPPED BOX CARS No's. 67420 TO 67430
 AAR MECHANICAL DESIGNATION = XL

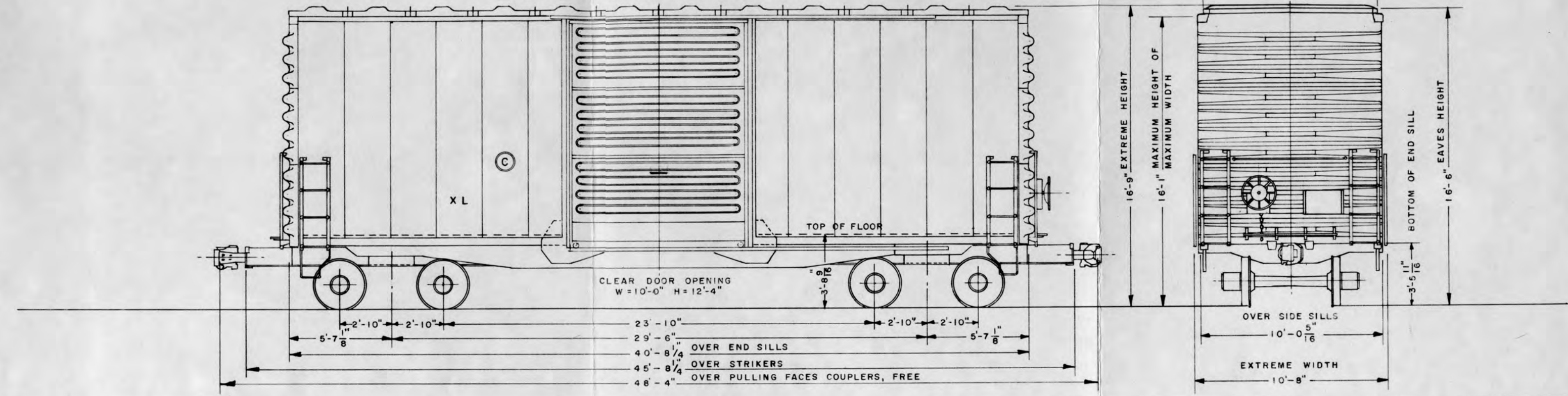

DESCRIPTION

<p><u>LOADER COMPLEMENT</u> 67420-67426</p> <p>MOVABLE BULKHEADS - CRECO ONE-PIECE ----- 2</p>	<p>GAUGE ----- 4'-8 1/2"</p> <p>JOURNALS ----- 2 x 11 ----- 6" X 11" TIMKEN ROLLER BEARINGS</p> <p>WHEELS ----- (J-33) 33" WROT STEEL 1-W</p> <p>AXLES ----- D-II-1967</p> <p>TRUCK TYPE ----- ASF A-3 RIDE CONTROL, 2 1/2" SPRING TRAVEL</p> <p>TRUCK SIDES ----- NARROW PEDESTAL TYPE</p>	<p>ROOF ----- PULLMAN STANDARD - 14 GA. GALVANIZED STEEL</p> <p>ENDS ----- PULLMAN STANDARD 3-PIECE - CORRUGATED STEEL</p> <p>SIDES ----- COPPER BEARING STEEL</p> <p>LINING - SIDES AND ENDS ----- T & G - YELLOW PINE</p> <p>FLOOR ----- 2 3/8" DURAWOOD</p> <p>DOORS ----- PULLMAN STANDARD - SLIDING TYPE</p> <p>DOOR FIXTURES ----- PULLMAN STANDARD</p>	<p>MARKED CAPACITY, LBS. ----- 150,000</p> <p>LIGHT WEIGHT, LBS., AV. (67420-67426) ----- 64,300</p> <p>MAXIMUM WEIGHT OF LADING, LBS., AV. (67420-67426) ----- 150,000</p> <p>LIGHT WEIGHT, LBS., AV. (67427-67430) ----- 63,000</p> <p>MAXIMUM WEIGHT OF LADING, LBS., AV. (67427-67430) ----- 150,000</p> <p>CUBICAL CAPACITY, CU. FT. (67420-67426) ----- 4730</p> <p>CUBICAL CAPACITY, CU. FT. (67427-67430) ----- 4900</p>
<p><u>DF-2 LOADER COMPLEMENT</u> 67427-67430</p> <p>BELT RAILS ----- 15</p> <p>CROSSMEMBERS (ALUMINUM) ----- 8</p> <p>DOORWAY MEMBERS ----- 8</p> <p>DECKBOARDS - 54" X 144" ----- 4</p> <p>SWINGBOARDS - 8" ----- 4</p> <p>SWINGBOARDS - 12" ----- 4</p>	<p>SIDE BEARINGS ----- BARBER MONOCAST - TYPE NO. 20</p> <p>BRAKE BEAMS ----- BUFFALO NO. 24</p> <p>BRAKE SHOES ----- AAR 1-A</p>	<p>UNDERFRAME ----- HYDRA-CUSHION - 20" TRAVEL</p> <p>DRAFT GEAR ----- WAUGHMAT CUSHION - TYPE WM-CG-5</p> <p>COUPLER ----- 6 1/4" X 8" X 21 1/2" SHANK, AAR TYPE E</p> <p>BRAKE ----- WESTINGHOUSE ABD 1012</p> <p>BRAKE SLACK ADJUSTER ----- ELLCON NATIONAL - MODEL 1340</p> <p>HAND BRAKE ----- AJAX</p> <p>CROSSOVER STEPS ----- APEX</p>	<p>LENGTH INSIDE ----- 40'-6"</p> <p>WIDTH INSIDE ----- 9'-6"</p> <p>HEIGHT INSIDE ----- 12'-9"</p> <p>YEAR BUILT ----- 1967</p> <p>BUILDER ----- PULLMAN STANDARD CAR MFG. CO.</p>

DENVER & RIO GRANDE WESTERN R. R.
 BOX CARS No's. 67500 to 67999

AAR MECHANICAL DESIGNATION = XM

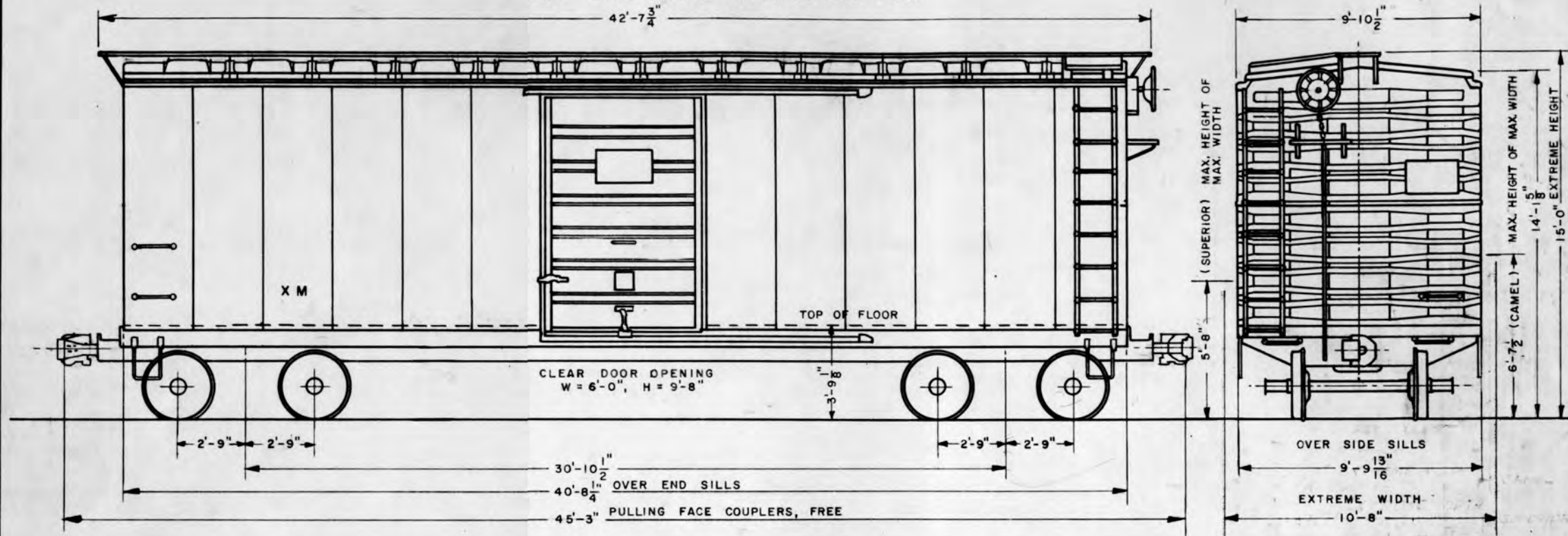

DESCRIPTION

GAUGE	4'-8 1/2"	ROOF	MURPHY IMPROVED-SOLID STEEL	MARKED CAPACITY, LBS.	110,000
JOURNALS	5 1/2" X 10"	ENDS	IMPROVED DREADNAUGHT 2-PIECE	LIGHT WEIGHT, LBS., AV.	43,400
WHEELS	33" WROT STEEL 1-W	SIDES	HIGH TENSILE STEEL-WOOD LINING	MAX. WEIGHT OF LADING, LBS., AV.	133,600
TRUCK TYPE	ASF A-3 RIDE CONTROL, SPRING PLANKLESS	UNDERFRAME	DURYEA	CUBICAL CAPACITY, CU. FT.	3850
SPRING TRAVEL	3 1/16"	FLOOR	WOOD OR PLASTINAIL	LENGTH INSIDE	40'-6 1/16"
TRUCK SIDES	CAST STEEL- INTEGRAL BOXES	DOORS (67500-67749)	YOUNGSTOWN	WIDTH INSIDE	9'-2 1/4"
TRUCK BOLSTER	CAST STEEL	DOORS (67750-67999)	SUPERIOR	HEIGHT INSIDE	10'-4 3/16"
SIDE BEARINGS	STUCKI	DOOR FIXTURES (67500-67749)	CAMEL-ROLLER LIFT		
		DOOR FIXTURES (67750-67999)	SUPERIOR		
		DRAFT GEAR	DURYEA		
		COUPLER	AAR TYPE E		
		BRAKE	AB 1012		
		HAND BRAKE (67500-67749)	AJAX		
		HAND BRAKE (67750-67999)	UNIVERSAL		
		BRAKE SLACK ADJUSTER	ROYAL-TYPE F	YEAR BUILT	1946
		RUNNING BOARDS (67500-67749)	STEEL-APEX	BUILDERS	PRESSED STEEL CAR CO.
		RUNNING BOARDS (67750-67999)	STEEL-GYPSUM		

DENVER & RIO GRANDE WESTERN R.R.
 BOX CARS No's. 68000 to 68399

F-51

AAR MECHANICAL DESIGNATION = XM

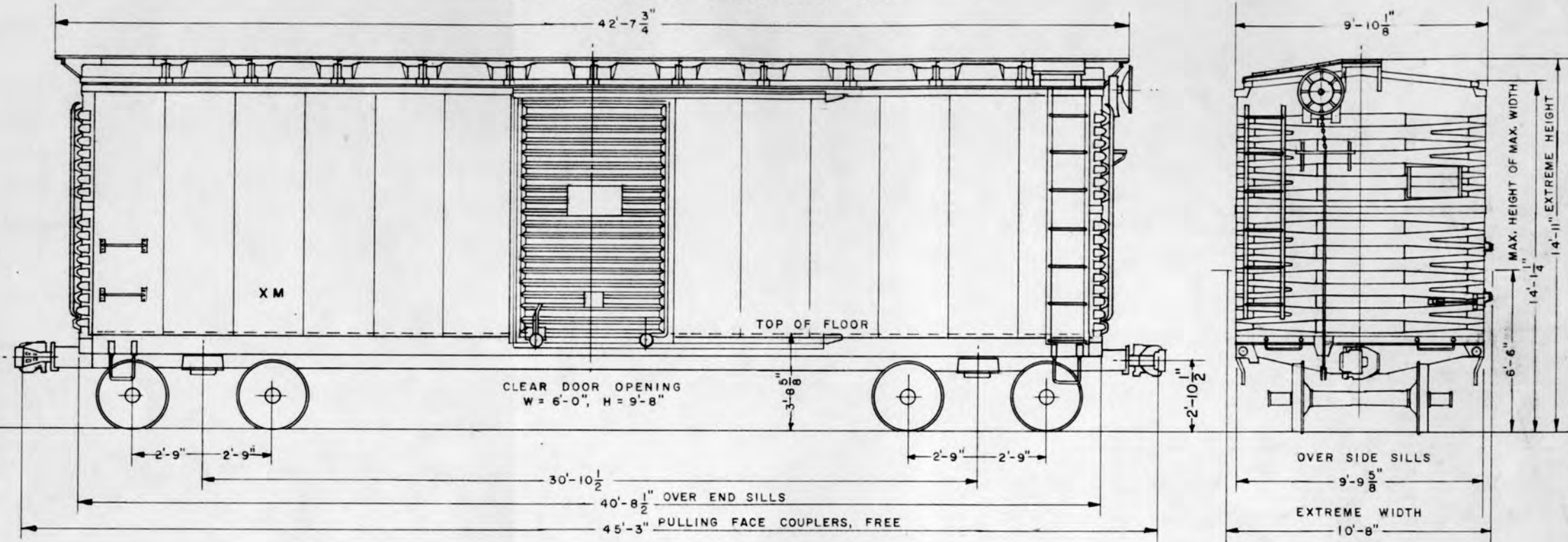

DESCRIPTION

GAUGE ----- 4'-8 1/2"
 JOURNALS ----- 5 1/2" X 10 1/2"
 WHEELS - 68000-68099 ----- 33" WROT STEEL I-W
 WHEELS - 68100-68399 ----- 33" CAST IRON
 TRUCK TYPE ----- TRUCK ASSOCIATION-RADIAL SPRING PLANKLESS
 TRUCK SIDES ----- CAST STEEL- INTEGRAL BOXES
 TRUCK BOLSTER ----- CAST STEEL
 SIDE BEARINGS ----- STUCKI

ROOF ----- MURPHY IMPROVED SOLID STEEL
 ENDS ----- DREADNAUGHT- 2 PIECE
 SIDES ----- HIGH TENSILE STEEL- WOOD LINING
 UNDERFRAME ----- STEEL-DURYEA
 FLOOR ----- WOOD OR PLASTINAIL

DOORS ----- YOUNGSTOWN
 DOOR FIXTURES ----- CAMEL-ROLLER LIFT

DRAFT GEAR ----- DURYEA
 COUPLER ----- AAR TYPE E
 BRAKE ----- AB 1012
 HAND BRAKE ----- AJAX
 BRAKE SLACK ADJUSTER ----- ROYAL-TYPE F

RUNNING BOARDS ----- WOOD

MARKED CAPACITY, LBS. ----- 110,000
 LIGHT WEIGHT, LBS. - 68000-68099 ----- 41,300
 MAX. WEIGHT OF LADING, LBS- 68000-68099 ----- 135,700
 LIGHT WEIGHT, LBS. - 68100-68399 ----- 42,700
 MAX. WEIGHT OF LADING, LBS.- 68100-68399 ----- 134,300
 CUBICAL CAPACITY, CU. FT. ----- 3840
 LENGTH INSIDE ----- 40'-6"
 WIDTH INSIDE ----- 9'-2"
 HEIGHT INSIDE ----- 10'-4 1/8"

YEAR BUILT ----- 1939
 BUILDERS ----- PRESSED STEEL CAR CO.

REISSUE
 JAN. 2, 1961.
 JAN. 2, 1962.
 JAN. 2, 1963.
 JAN. 2, 1968.

DENVER & RIO GRANDE WESTERN R. R.
 BOX CARS No's. 68400 TO 68899

F-52

AAR MECHANICAL DESIGNATION = XM

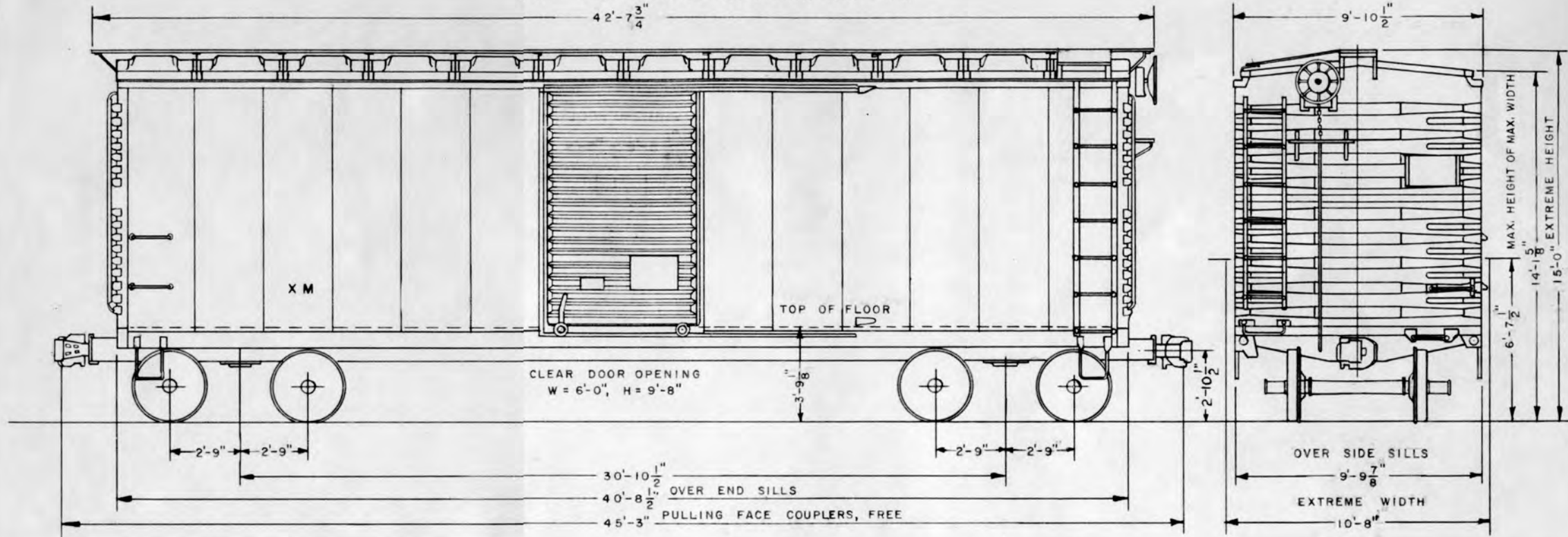

DESCRIPTION

GAUGE ----- 4'-8 1/2"
 JOURNALS ----- 5 1/2" X 10"
 WHEELS ----- 33" WROT STEEL I-W
 TRUCK SIDES ----- CAST STEEL- INTEGRAL BOXES
 TRUCK BOLSTER ----- CAST STEEL

68400 - 68799

TRUCK TYPE-TRUCK ASSO'N., FLAT COLUMN, SPRING PLANK
 SIDE BEARINGS ----- STUCKI

68800 - 68899

TRUCK TYPE ----- BARBER STABILIZED- SPRING PLANK
 SIDE BEARINGS ----- BARBER MONOCAST

ROOF ----- MURPHY IMPROVED-SOLID STEEL
 ENDS ----- DREADNAUGHT 2-PIECE
 SIDES ----- HIGH TENSILE STEEL- WOOD LINING
 UNDERFRAME ----- DURYEA
 FLOOR ----- WOOD OR PLASTINAIL

DOORS ----- YOUNGSTOWN
 DOOR FIXTURES ----- CAMEL-ROLLER LIFT

DRAFT GEAR ----- DURYEA
 COUPLER ----- AAR TYPE E
 BRAKE ----- AB 1012
 HAND BRAKE ----- AJAX
 BRAKE SLACK ADJUSTER ----- ROYAL-TYPE F

RUNNING BOARDS (68400-68799) ----- STEEL-APEX
 RUNNING BOARDS (68800-68899) ----- STEEL-BLAW KNOX

MARKED CAPACITY, LBS. ----- 110,000
 LIGHT WEIGHT, LBS., AV. ----- 42,900
 MAX. WEIGHT OF LADING, LBS., AV. ----- 134,100
 CUBICAL CAPACITY, CU. FT. ----- 3850
 LENGTH INSIDE ----- 40'-6"
 WIDTH INSIDE ----- 9'-2 1/4"
 HEIGHT INSIDE ----- 10'-4 1/4"

YEAR BUILT ----- 1940
 BUILDERS ----- PRESSED STEEL CAR CO.

DENVER & RIO GRANDE WESTERN R. R.
 BOX CARS No's. 68900 to 69399
 AAR MECHANICAL DESIGNATION = XM

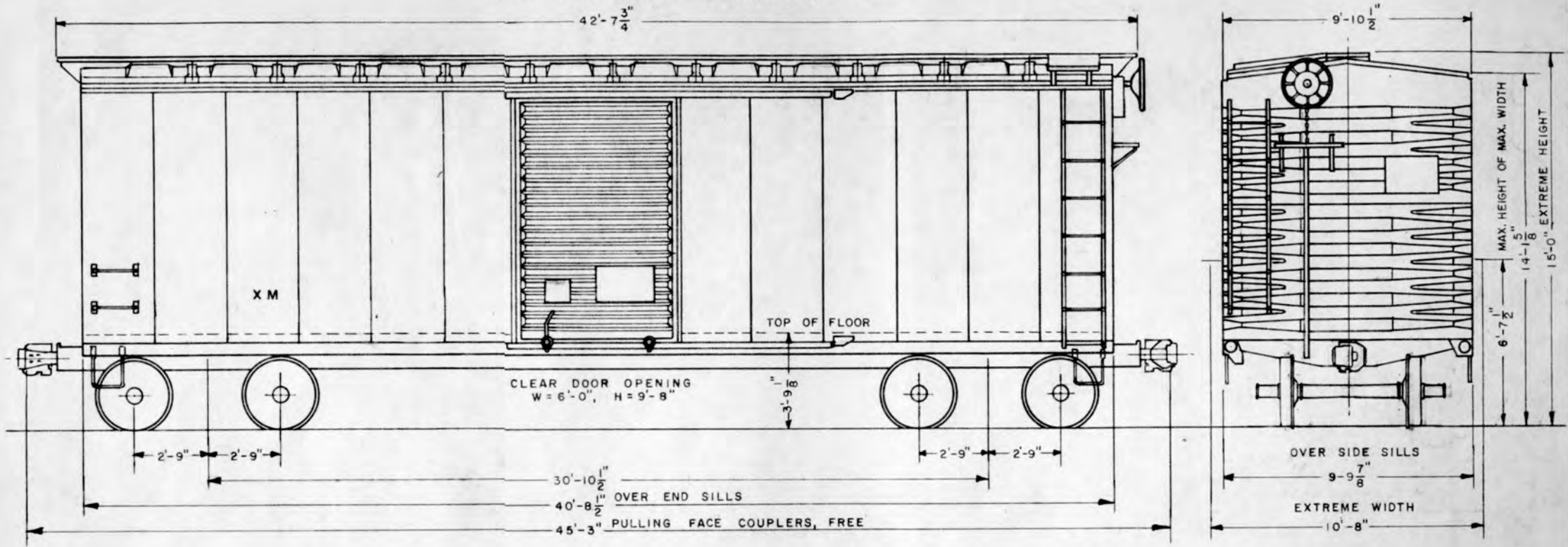

DESCRIPTION

GAUGE ----- 4'-8 1/2"	ROOF ----- MURPHY IMPROVED - SOLID STEEL	MARKED CAPACITY, LBS. ----- 110,000
JOURNALS ----- 5 1/2" X 10"	ENDS ----- DREADNAUGHT 2-PIECE	LIGHT WEIGHT, LBS., AV. ----- 42,500
WHEELS ----- 33" WROT STEEL 1-W	SIDES ----- HIGH TENSILE STEEL-WOOD LINING	MAX. WEIGHT OF LADING, LBS., AV. ----- 134,500
TRUCK SIDES ----- CAST STEEL-INTEGRAL BOXES	UNDERFRAME ----- DURYE A	CUBICAL CAPACITY, CU. FT. ----- 3850
TRUCK BOLSTER ----- CAST STEEL	FLOOR ----- WOOD OR PLASTINAIL	LENGTH INSIDE ----- 40'-6"
68900-69299	DOORS ----- YOUNGSTOWN	WIDTH INSIDE ----- 9'-2 1/4"
TRUCK TYPE - TRUCK ASSO'N, FLAT COLUMN, SPRING PLANK	DOOR FIXTURES ----- CAMEL-ROLLER LIFT	HEIGHT INSIDE ----- 10'-4 3/16"
SIDE BEARINGS ----- STUCKI	DRAFT GEAR ----- DURYE A	
69300-69399	COUPLER ----- AAR TYPE E	
TRUCK TYPE ----- BARBER STABILIZED-SPRING PLANK	BRAKE ----- AB 1012	
SIDE BEARINGS ----- BARBER MONOCAST	HAND BRAKE ----- AJAX	
	BRAKE SLACK ADJUSTER ----- ROYAL TYPE F	
	RUNNING BOARDS (68900-69199) ----- STEEL-APEX	YEAR BUILT ----- 1941
	RUNNING BOARDS (69200-69349) ----- STEEL-GYPSUM	BUILDERS ----- PRESSED STEEL CAR CO.
	RUNNING BOARDS (69350-69399) ----- STEEL-MORTON	

REISSUE
 JAN. 2, 1962.
 JAN. 2, 1963.
 JAN. 2, 1968.

DENVER & RIO GRANDE WESTERN R.R.
 BOX CARS No's. 69400 TO 69899

F-54

AAR MECHANICAL DESIGNATION = XM

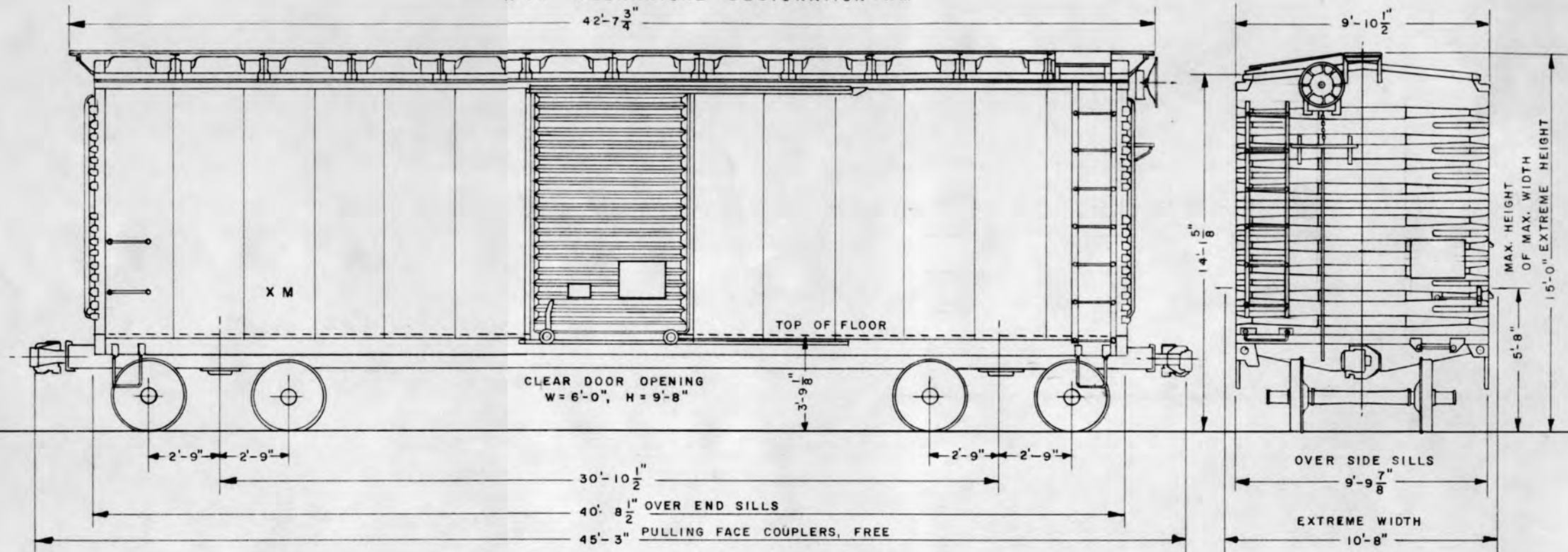

DESCRIPTION

GAUGE ----- 4'-8 1/2"
 JOURNALS ----- 5 1/2" X 10"
 WHEELS ----- 33" WROT STEEL 1-W
 TRUCK TYPE --- TRUCK ASS'N.-FLAT COLUMN-SPRING PLANK
 TRUCK SIDES --- CAST STEEL- INTEGRAL BOXES
 TRUCK BOLSTER ----- CAST STEEL
 SIDE BEARINGS ----- STUCKI

ROOF ----- MURPHY- IMPROVED SOLID STEEL
 ENDS ----- DREADNAUGHT 2-PIECE
 SIDES ----- HIGH TENSILE STEEL- WOOD LINING
 FLOOR ----- WOOD OR PLASTINAIL

MARKED CAPACITY, LBS. ----- 110,000
 LIGHT WEIGHT, LBS., AV. ----- 42,700
 MAX. WEIGHT OF LADING, LBS., AV. ----- 134,300

UNDERFRAME ----- DURYEA
 DOORS ----- SUPERIOR
 DOOR FIXTURES ----- SUPERIOR

CUBICAL CAPACITY, CU. FT. ----- 3850

DRAFT GEAR ----- DURYEA
 COUPLER ----- AAR TYPE E
 BRAKE ----- AB 1012
 HAND BRAKE ----- AJAX
 BRAKE SLACK ADJUSTER ----- ROYAL TYPE F

LENGTH INSIDE ----- 40'-6"
 WIDTH INSIDE ----- 9'-2 1/4"

HEIGHT INSIDE ----- 10'-4 3/16"

69800 - 69899 ONLY

TRUCK TYPE --- BARBER STABILIZED- SPRING PLANK
 TRUCK SIDES --- CAST STEEL- INTEGRAL BOXES
 SIDE BEARINGS ----- BARBER MONOCAST

RUNNING BOARDS (68400-69649) ----- APEX-STEEL
 RUNNING BOARDS (69650-69899) ----- U.S. GYPSUM CO.- STEEL

YEAR BUILT ----- 1942
 BUILDERS ----- PRESSED STEEL CAR CO.

DENVER & RIO GRANDE WESTERN R.R.
 ARTICULATED WOOD CHIP CARS No's. 67431-A&B TO 67450-A&B
 AAR MECHANICAL DESIGNATION = XP

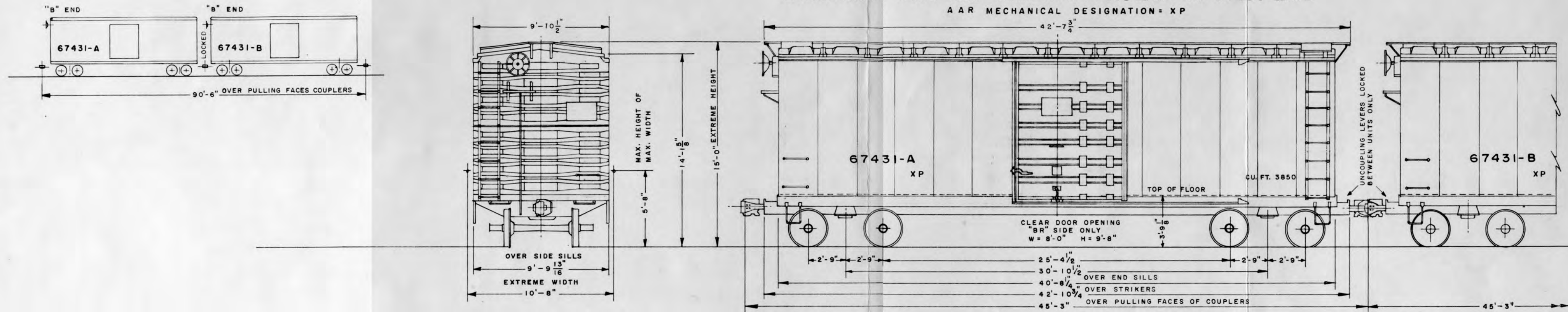

DESCRIPTION

PRESENT NUMBER	FORMER NUMBER	PRESENT NUMBER	FORMER NUMBER
67431-A	69774	67441-A	67894
67431-B	67968	67441-B	69853
67432-A	67936	67442-A	67908
67432-B	69468	67442-B	69483
67433-A	67899	67443-A	69812
67433-B	69402	67443-B	69726
67434-A	69833	67444-A	67762
67434-B	69490	67444-B	69743
67435-A	67817	67445-A	67836
67435-B	67793	67445-B	67924
67436-A	68688	67446-A	69662
67436-B	67786	67446-B	69748
67437-A	67779	67447-A	69634
67437-B	67989	67447-B	67931
67438-A	67886	67448-A	67859
67438-B	67882	67448-B	67868
67439-A	69739	67449-A	67824
67439-B	67933	67449-B	69804
67440-A	67814	67450-A	67974
67440-B	69658	67450-B	69574

GAUGE	4'-8 1/2"
JOURNALS	5 1/2" x 10"
WHEELS	33" WROT STEEL I-W
ASF A-3 RIDE CONTROL TRUCKS WITH 3 1/16" SPRING TRAVEL	
67431-B, 67432-A, 67433-A, 67435-A, 67435-B, 67436-B, 67437-A, 67437-B, 67438-A, 67438-B, 67439-B, 67440-A, 67441-A, 67442-A, 67444-A, 67445-A, 67445-B, 67447-B, 67448-A, 67448-B, 67449-A, 67450-A.	
TRUCK ASSOCIATION TRUCKS - FLAT COLUMN, SPRING PLANK	
67431-A, 67432-B, 67433-B, 67434-B, 67436-A, 67439-A, 67440-B, 67442-B, 67443-B, 67444-B, 67446-A, 67446-B, 67447-A, 67450-B.	
BARBER STABILIZED TRUCKS - SPRING PLANK	
67434-A, 67441-B, 67443-A, 67449-B.	
SIDE BEARINGS	67434-A, 67441-B, 67443-A, 67449-B BARBER
REMAINING 36 CARS	STUCKI ROLLER

ROOF	MURPHY IMPROVED-SOLID STEEL
ENDS	DREADNAUGHT 2-PIECE
SIDES	HIGH TENSILE STEEL
FLOOR	WOOD OR WOOD AND PLASTINAIL
DOORS - ONE 8 FEET WIDE, ONE PERMANENTLY SEALED - SUPERIOR	
DOOR FIXTURES - SUPERIOR	
DRAFT GEAR	DURYEA
COUPLER	AAR TYPE E
UNCOUPLING LEVERS - MANUAL LOCKING DEVICE BETWEEN UNITS	
BRAKE	AB 1012
HAND BRAKE	UNIVERSAL OR AJAX
HAND BRAKE - SEE PAGES F-50, F-52 AND F-54 FOR CAR NUMBERS (FORMER NUMBERS)	
BRAKE SLACK ADJUSTER	ROYAL - TYPE F

MARKED CAPACITY, LBS. - EACH UNIT	110,000
LIGHT WEIGHT, LBS., AV. - EACH UNIT	42,700
MAXIMUM WEIGHT OF LADING, LBS., AV. - EACH UNIT	134,300
MARKED CAPACITY, LBS. - ARTICULATED	220,000
LIGHT WEIGHT, LBS., AV. - ARTICULATED	85,400
MAXIMUM WEIGHT OF LADING, LBS., AV. - ARTICULATED	268,600
CUBICAL CAPACITY, CU. FT. - EACH UNIT (STENCILED)	3,850
CUBICAL CAPACITY, CU. FT. - ARTICULATED	7,700
LENGTH INSIDE - EACH UNIT	40'-7 5/8"
WIDTH INSIDE - EACH UNIT	9'-9 7/8"
HEIGHT INSIDE - EACH UNIT	9'-8 3/4"
YEAR BUILT	1940, 1942, 1946
MODIFIED BY D & R G W	1967
BUILDER	PRESSED STEEL CAR CO.

DENVER & RIO GRANDE WESTERN R.R.
 DOUBLE DECK STOCK CARS No's. 36000 to 36099

AAR MECHANICAL DESIGNATION - SF

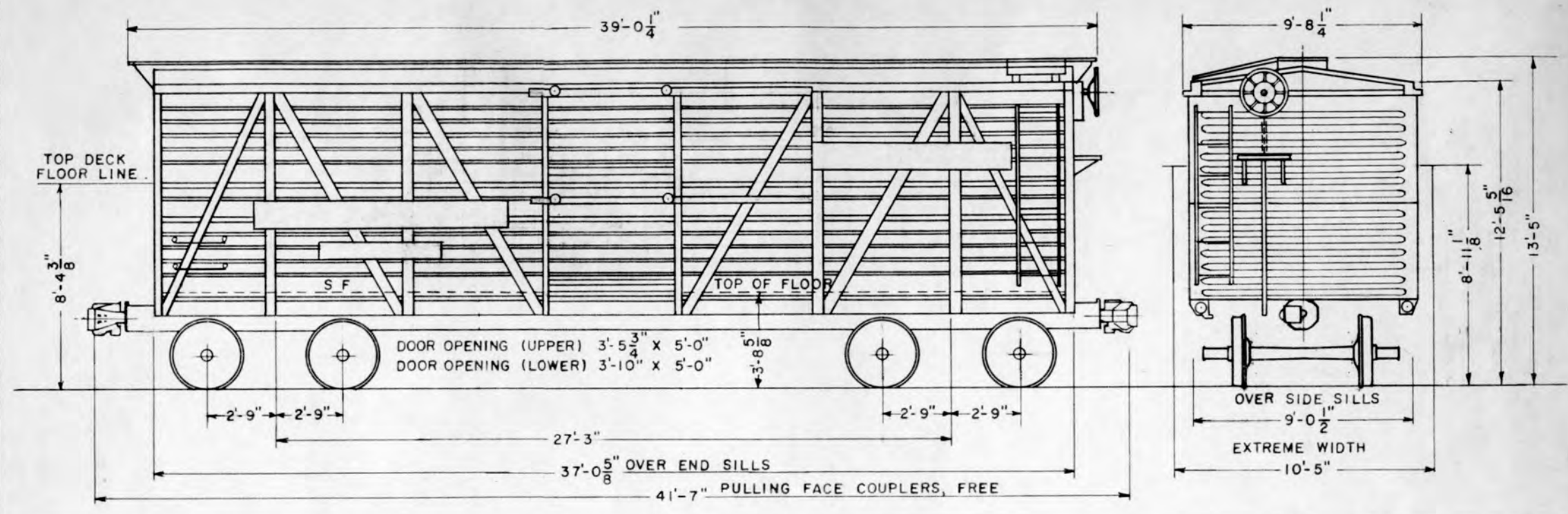

DESCRIPTION

GAUGE	4'-8 1/2"	ROOF	MURPHY-PRESSED STEEL	MARKED CAPACITY, LBS.	88,000
JOURNALS	5" X 9"	ENDS	MURPHY 2-PIECE	LIGHT WEIGHT, LBS., AV.	41,000
WHEELS	33" CAST IRON	SIDES	WOOD-STEEL FRAME	MAX. WEIGHT OF LADING, LBS., AV.	95,000
TRUCK TYPE	BETTENDORF-SPRING PLANK	UNDERFRAME	DURYEA-STEEL	CUBICAL CAPACITY, CU. FT.	2800
TRUCK SIDES	CAST STEEL-INTEGRAL BOXES	FLOORS	WOOD	LENGTH INSIDE	36'-6"
TRUCK BOLSTER	CAST STEEL	DOORS	WOOD-STEEL BOUND	WIDTH INSIDE	8'-10"
SIDE BEARINGS	BARBER	DOOR FIXTURES	CAMEL	HEIGHT INSIDE (LOWER DECK)	4'-3 3/8"
		DRAFT GEAR	DURYEA	HEIGHT INSIDE (UPPER DECK)	4'-0 3/8"
		COUPLER	AAR TYPE E		
		BRAKE	AB		
		HAND BRAKE	AJAX		
		BRAKE GEAR REGULATOR	ROYAL TYPE K		
		DOUBLE DECK	PERMANENT	YEAR BUILT	1939-1940
		RUNNING BOARDS	WOOD	BUILDERS	D & R G W

DENVER & RIO GRANDE WESTERN R.R.
 DOUBLE DECK STOCK CARS No's. 36100 to 36199

AAR MECHANICAL DESIGNATION = SF

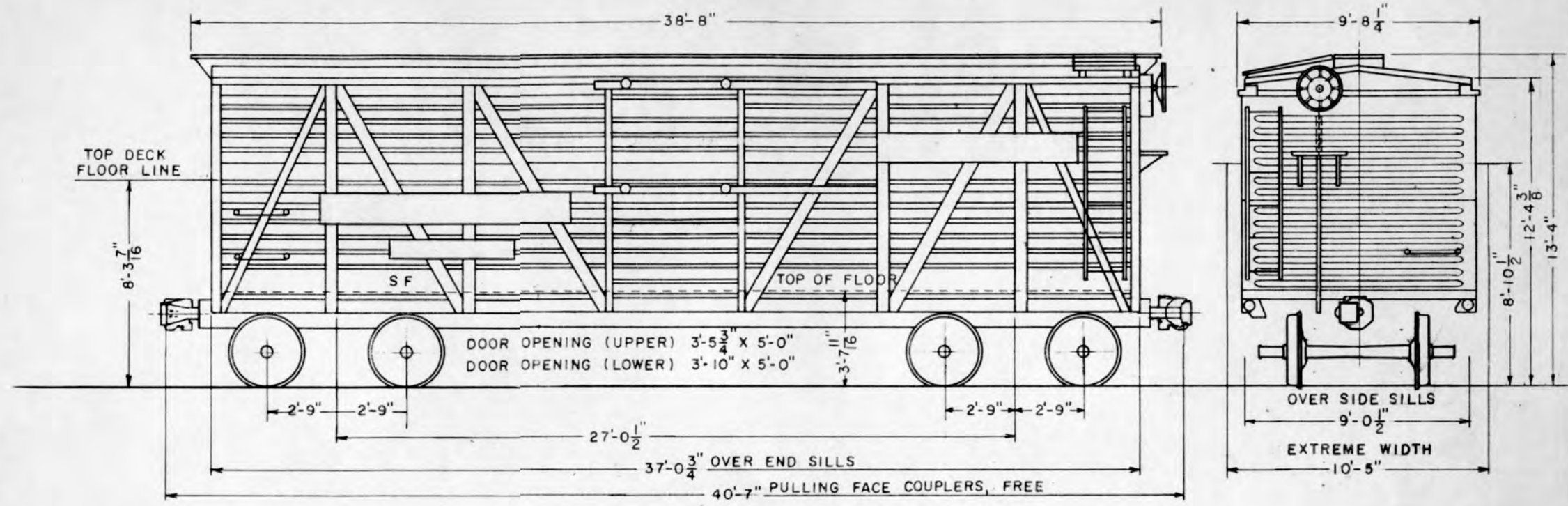

DESCRIPTION

GAUGE	4'-8 1/2"	ROOF	MURPHY-PRESSED STEEL	MARKED CAPACITY, LBS.	88,000
JOURNALS	5" x 9"	ENDS	MURPHY 2-PIECE	LIGHT WEIGHT, LBS., AV.	40,000
WHEELS	33" CAST IRON	SIDES	WOOD-STEEL FRAME	MAX. WEIGHT OF LADING, LBS., AV.	96,000
TRUCK TYPE	BETTENDORF-SPRING PLANK	UNDERFRAME	STEEL	CUBICAL CAPACITY, CU. FT.	2800
TRUCK SIDES	CAST STEEL-INTEGRAL BOXES	FLOORS	WOOD	LENGTH INSIDE	36'-6"
TRUCK BOLSTER	CAST STEEL	DOORS	WOOD-STEEL BOUND	WIDTH INSIDE	8'-10"
SIDE BEARINGS	BARBER	DOOR FIXTURES	CAMEL	HEIGHT INSIDE (LOWER DECK)	4'-3"
		DRAFT GEAR	CARDWELL-WESTINGHOUSE NY-II-E	HEIGHT INSIDE (UPPER DECK)	4'-0 3/8"
		COUPLER	AAR TYPE E		
		BRAKE	AB		
		HAND BRAKE	AJAX		
		DOUBLE DECK	PERMANENT	YEAR BUILT	1942
		RUNNING BOARDS	WOOD	BUILDERS	D & R G W

DENVER & RIO GRANDE WESTERN R. R.
DOUBLE DECK STOCK CARS No's. 36400 to 36499

AAR MECHANICAL DESIGNATION = SF

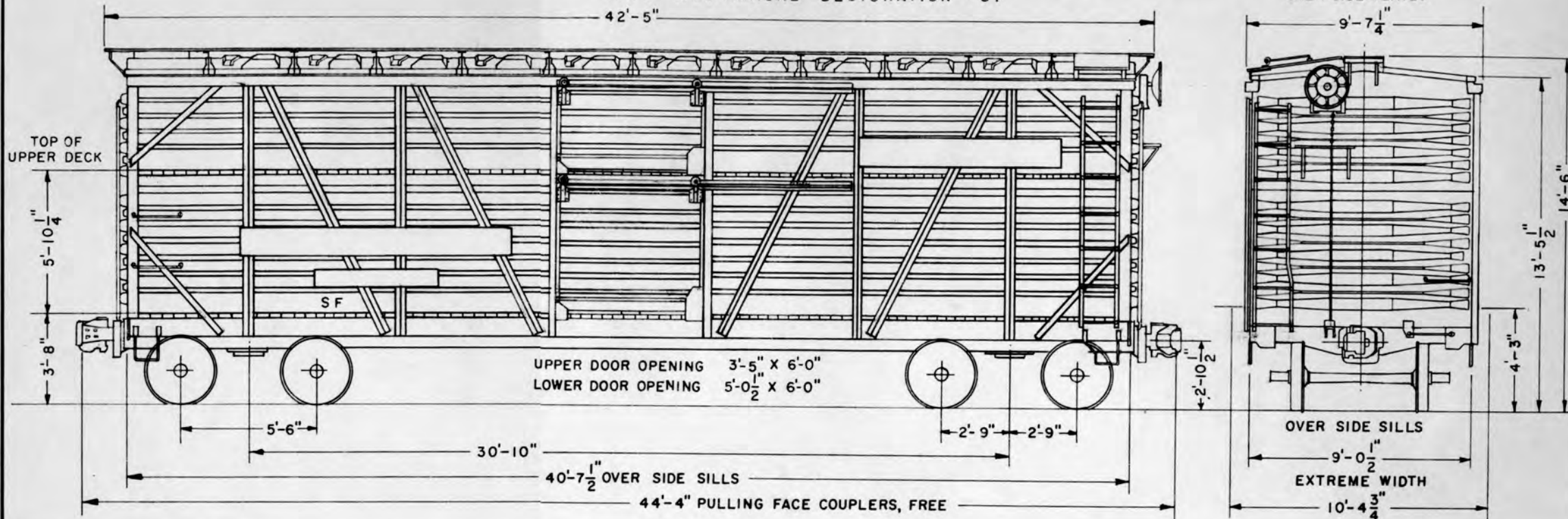

DESCRIPTION

GAUGE ----- 4'-8 1/2"
JOURNALS ----- 5" X 9"
WHEELS ----- 33" CAST IRON
TRUCK TYPE { ASF A-3 RIDE CONTROL, SPRING PLANKLESS
 2 1/2" SPRING TRAVEL
TRUCK SIDES ----- CAST STEEL-INTEGRAL BOXES
TRUCK BOLSTER ----- CAST STEEL
SIDE BEARINGS ----- STUCKI
UNIT TYPE BRAKE BEAMS NO. 18 ----- DAVIS

ROOF ----- STANDARD RY. EQUIPT. CO. DIAGONAL PANEL-STEEL
ENDS ----- STANDARD RY. EQUIPT. CO. ----- 2-PIECE
SIDES ----- WOOD-STEEL FRAME
UNDERFRAME ----- STEEL
DOORS ----- CAMEL - WOOD, STEEL BOUND
DOOR FIXTURES ----- CAMEL
DRAFT GEAR - 36400-36449 ----- MINER A-22-XL
DRAFT GEAR - 36450-36499 ----- CARDWELL-WEST, NY-II-F
COUPLER ----- AAR TYPE E
BRAKE ----- AB
HAND BRAKE ----- MINER
BRAKE GEAR REGULATOR ----- ROYAL TYPE F

MARKED CAPACITY, LBS. ----- 88,000
LIGHT WEIGHT, LBS. ----- 46,500
MAX. WEIGHT OF LADING, LBS. ----- 89,500
CUBICAL CAPACITY, CU. FT. ----- 3526
LENGTH INSIDE ----- 40'-7 5/8"
WIDTH INSIDE ----- 8'-10"
HEIGHT INSIDE-LOWER DECK ----- 5'-8"
HEIGHT INSIDE-UPPER DECK ----- 4'-2"

DOUBLE DECK ----- PERMANENT
RUNNING BOARDS ----- U.S. GYPSUM CO.

YEAR BUILT ----- 1955
BUILDERS ----- D. & R. G. W.

DENVER & RIO GRANDE WESTERN R.R.
STOCK CARS No's. 39000 to 39099
AAR MECHANICAL DESIGNATION - SM

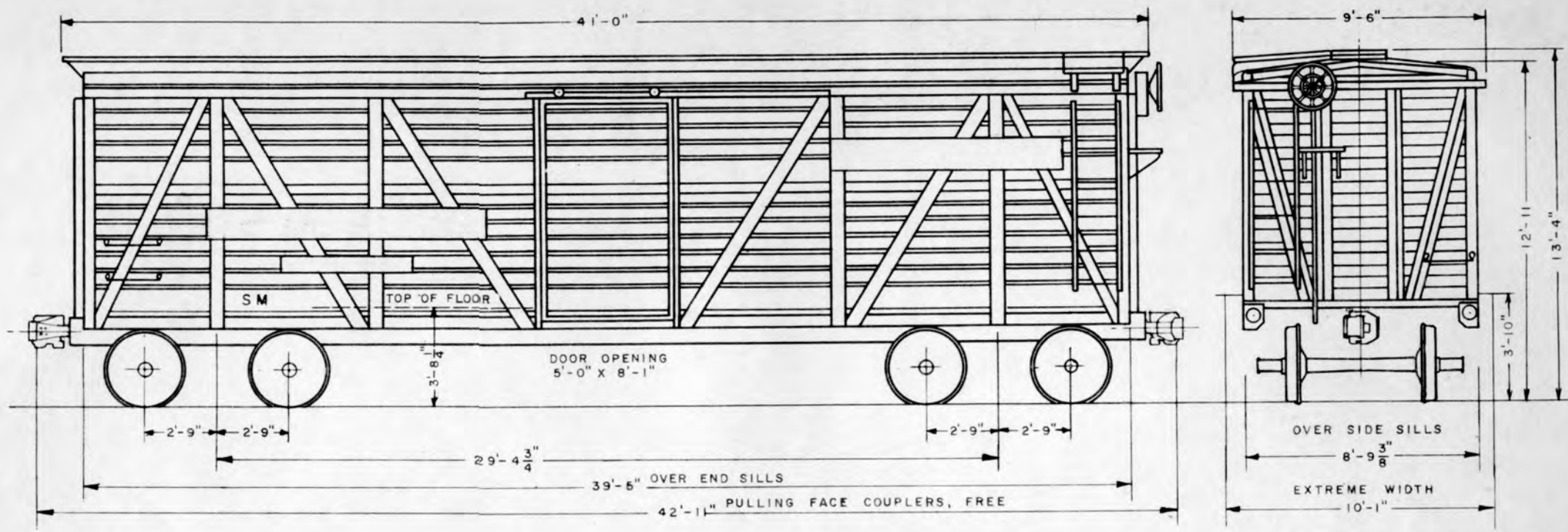

DESCRIPTION

GAUGE -----	4'-8 1/2"	ROOF -----	MURPHY-PRESSED STEEL	MARKED CAPACITY, LBS. -----	88,000
JOURNALS -----	5" X 9"	ENDS -----	WOOD-STEEL FRAME	LIGHT WEIGHT, LBS., AV. -----	39,200
WHEELS -----	33" CAST IRON	SIDES -----	WOOD-STEEL FRAME	MAX. WEIGHT OF LADING, LBS., AV. -----	96,800
TRUCK TYPE -----	ANDREWS	UNDERFRAME -----	STEEL	CUBICAL CAPACITY, CU. FT. -----	2877
TRUCK SIDES -----	CAST STEEL - SEPARATE BOXES	DOORS -----	WOOD-STEEL BOUND	LENGTH INSIDE -----	39'-1"
TRUCK BOLSTER -----	CAST STEEL	DOOR FIXTURES -----	AAR	WIDTH INSIDE -----	8'-6"
SIDE BEARINGS -----	BARBER	DRAFT GEAR -----	CARDWELL-WESTINGHOUSE NY-II-E	HEIGHT INSIDE -----	8'-7"
		COUPLER -----	AAR TYPE E		
		BRAKE -----	AB		
		HAND BRAKE -----	AJAX	YEAR BUILT -----	1937
				BUILDERS -----	D & R G W
		RUNNING BOARDS -----	WOOD		

DENVER & RIO GRANDE WESTERN R. R.

STOCK CARS No's. 39100 to 39199

AAR MECHANICAL DESIGNATION = SM

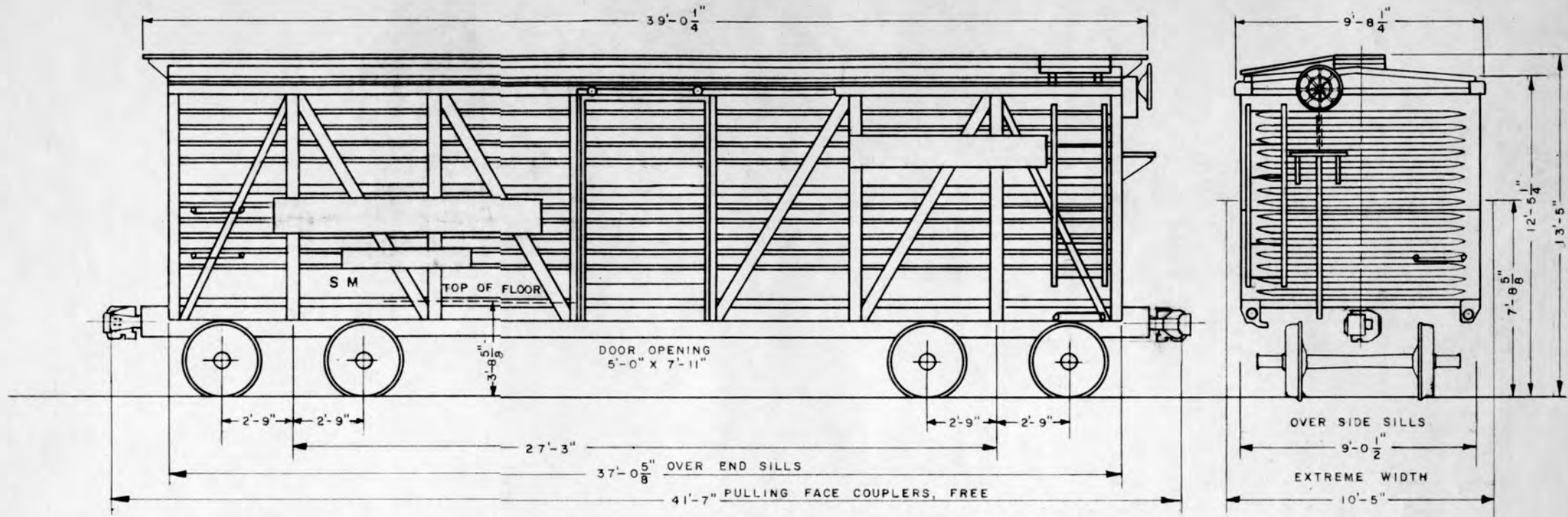

DESCRIPTION

GAUGE -----	4'-8 1/2"	ROOF -----	MURPHY - PRESSED STEEL	MARKED CAPACITY, LBS. -----	88,000
JOURNALS -----	5" X 9"	ENDS -----	MURPHY 2-PIECE	LIGHT WEIGHT, LBS., AV. -----	38,500
WHEELS -----	33" CAST IRON	SIDES -----	WOOD - STEEL FRAME	MAX. WEIGHT OF LADING, LBS., AV. -----	97,500
TRUCK TYPE -----	BETTENDORF - SPRING PLANK	UNDERFRAME -----	STEEL - DURYEA	CUBICAL CAPACITY, CU. FT. -----	2800
TRUCK SIDES -----	CAST STEEL - INTEGRAL BOXES	DOORS -----	WOOD - STEEL BOUND	LENGTH INSIDE -----	36'-6"
TRUCK BOLSTER -----	CAST STEEL	DOOR FIXTURES -----	CAMEL	WIDTH INSIDE -----	8'-10"
SIDE BEARINGS -----	BARBER	DRAFT GEAR -----	DURYEA	HEIGHT INSIDE -----	8'-8"
		COUPLER -----	AAR TYPE E		
		BRAKE -----	AB	YEAR BUILT -----	1940
		HAND BRAKE -----	AJAX	BUILDERS -----	D & R G W
		BRAKE SLACK ADJUSTER -----	ROYAL TYPE K		
		RUNNING BOARDS -----	WOOD		

DENVER & RIO GRANDE WESTERN R.R.

STOCK CARS No's. 39200 to 39399

AAR MECHANICAL DESIGNATION = SM

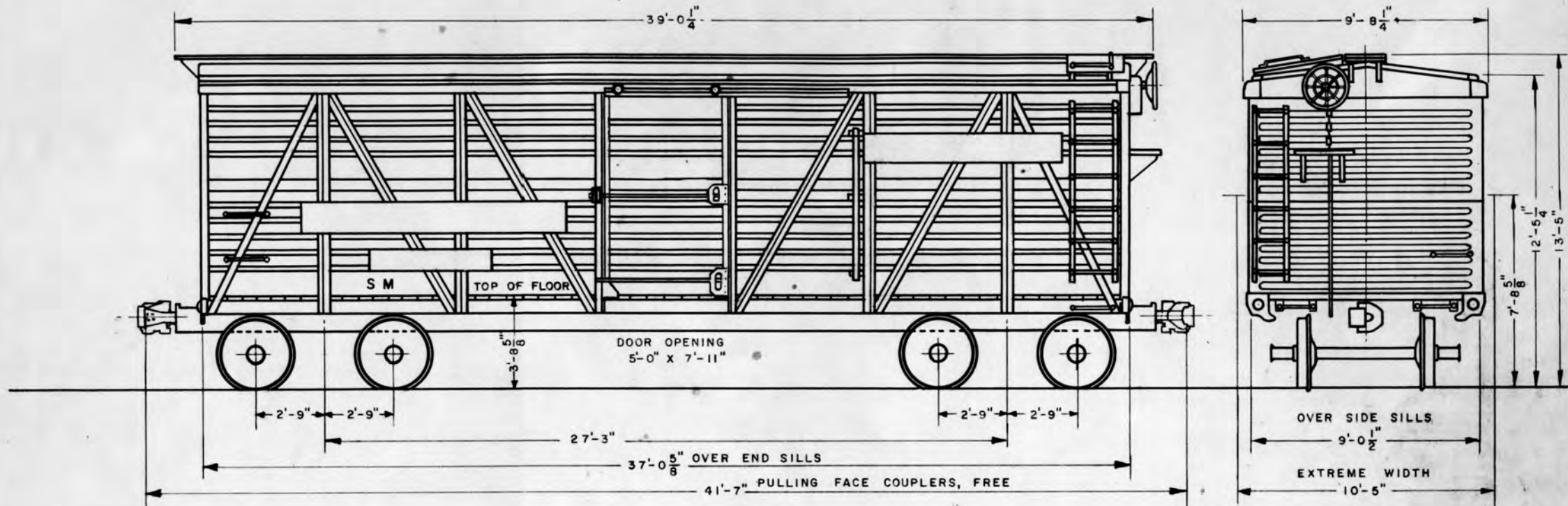

DESCRIPTION

GAUGE ----- 4'-8 ¹ / ₂ "	ROOF ----- MURPHY - PRESSED STEEL	MARKED CAPACITY, LBS. ----- 88,000
JOURNALS ----- 5" X 9"	ENDS ----- MURPHY - 2 PIECE	LIGHT WEIGHT, LBS., AV. ----- 39,300
WHEELS ----- 33" CAST IRON	SIDES ----- WOOD - STEEL FRAME	MAX. WEIGHT OF LADING, LBS., AV. ----- 96,700
TRUCK TYPE ----- BETTENDORF OR ANDREWS	UNDERFRAME ----- DURYEA	CUBICAL CAPACITY, CU. FT. ----- 2800
TRUCK SIDES - CAST STEEL ----- { INTEGRAL BOXES OR SEPARATE BOXES	DOORS ----- WOOD - STEEL BOUND	LENGTH INSIDE ----- 36'-6"
TRUCK BOLSTER ----- CAST STEEL	DOOR FIXTURES ----- CAMEL	WIDTH INSIDE ----- 8'-10"
SIDE BEARINGS ----- ROLLER	DRAFT GEAR ----- DURYEA	HEIGHT INSIDE ----- 8'-8"
	COUPLER ----- AAR TYPE E	
	BRAKE ----- AB	
	HAND' BRAKE ----- AJAX	
	BRAKE SLACK ADJUSTER ----- ROYAL TYPE K	
		YEAR BUILT ----- 1944, 1945
		BUILDERS ----- D & R G W
	RUNNING BOARDS ----- APEX - STEEL	

DENVER & RIO GRANDE WESTERN R.R.
GONDOLA DUMP CARS No. 71000 to 71999

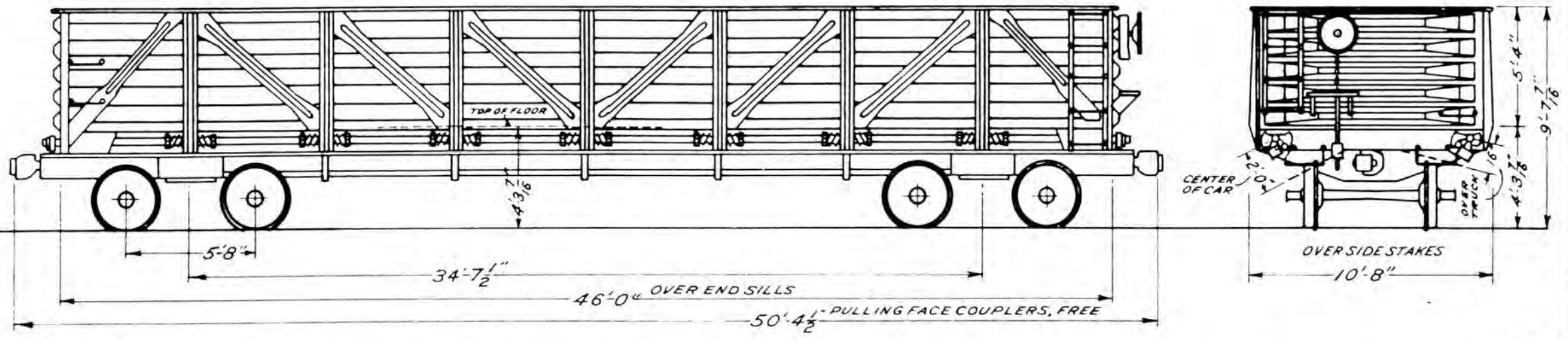

DESCRIPTION

GAUGE	4'-8 1/2"	ENDS	STEEL	MARKED CAPACITY, LBS.	140,000
JOURNALS	6"x11"	SIDES	COMPOSITE	LIGHT WEIGHT, LBS.	58,000
WHEELS	33" WROT STEEL I-W.	UNDERFRAME	STEEL-DURYEA	MAX. WEIGHT OF LADING, LBS.	152,000
TRUCK TYPE-TRUCK ASS.	FLAT COLUMN-SPRING PLANK	DOORS	16-CORRUGATED-STEEL	CUBICAL CAPACITY, LEVEL, CU.FT.	2,340
TRUCK SIDES	CAST STEEL-INTEGRAL BOXES	DOOR FIXTURES	CREEPING SHAFT TYPE	CUBICAL CAPACITY, HEAPED, CU.FT.	2,736
TRUCK BOLSTER	CAST STEEL	DRAFT GEAR	DURYEA	LENGTH INSIDE	46'-0"
SIDE BEARINGS	STUCKI	COUPLER	AAR TYPE E	WIDTH INSIDE	9'-5 3/4"
SNUBBERS { 71000-71527 }	CARDWELL-WESTINGHOUSE	BRAKE	AB	DEPTH INSIDE	5'-4"
SNUBBERS { 71778-71999 }	71528-71777 HOLLAND	HAND BRAKE { 71000-71799 }	AJAX		
		BRAKE GEAR REGULATOR	ROYAL TYPE F	YEAR BUILT	1943
				BUILDERS	PRESSED STEEL CAR CO

DENVER & RIO GRANDE WESTERN R.R.
STOCK CARS No's. 39400 to 39499

AAR MECHANICAL DESIGNATION = SM

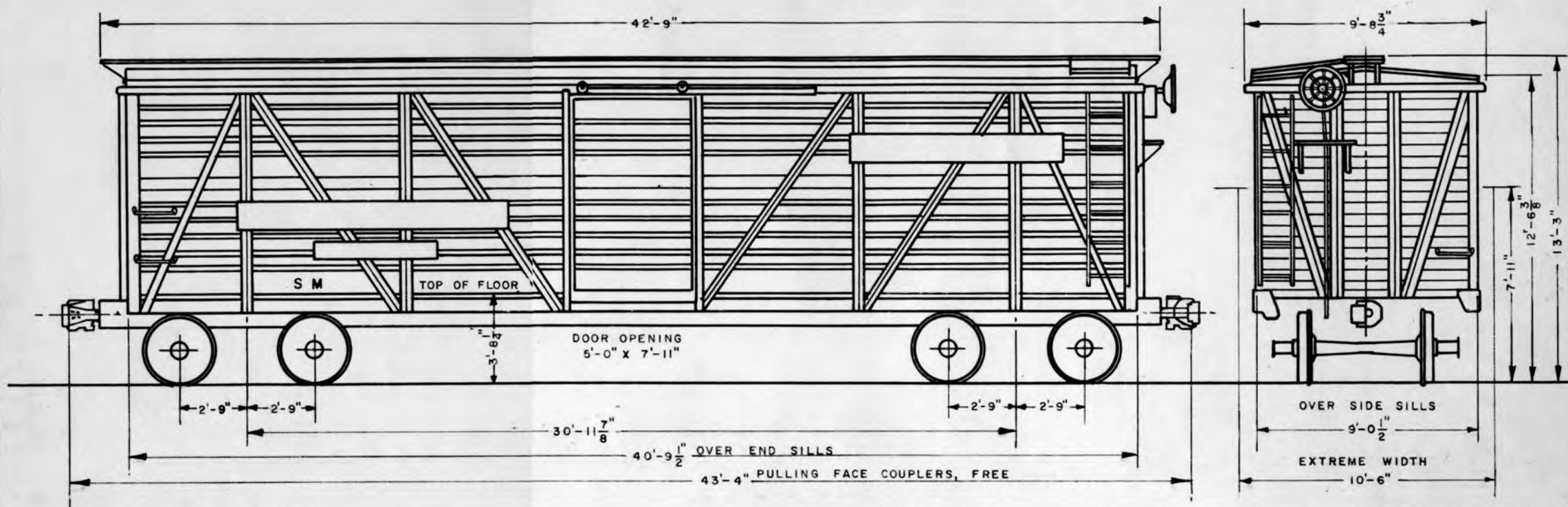

DESCRIPTION

GAUGE ----- 4'-8 1/2"	ROOF ----- MURPHY-RIVETED STEEL	MARKED CAPACITY, LBS. ----- 88,000
JOURNALS ----- 5" X 9"	ENDS ----- WOOD-STEEL FRAME	LIGHT WEIGHT, LBS., AV. ----- 40,000
WHEELS ----- 33" CAST IRON	SIDES ----- WOOD-STEEL FRAME	MAX. WEIGHT OF LADING, LBS., AV. ----- 96,000
TRUCK TYPE { ASF A-3 RIDE CONTROL, SPRING PLANKLESS 2 1/2" SPRING TRAVEL	UNDERFRAME ----- DURYEA	CUBICAL CAPACITY, CU. FT. ----- 3089
TRUCK SIDES ----- CAST STEEL-INTEGRAL BOXES	DOORS ----- WOOD-STEEL BOUND	LENGTH INSIDE ----- 40'-6"
TRUCK BOLSTER ----- CAST STEEL	DOOR FIXTURES ----- AAR	WIDTH INSIDE ----- 8'-10"
SIDE BEARINGS ----- STUCKI	DRAFT GEAR ----- DURYEA	HEIGHT INSIDE ----- 8'-8"
	COUPLER ----- AAR TYPE E	
	BRAKE ----- AB	
	HAND BRAKE ----- AJAX	
		YEAR BUILT ----- 1948
		BUILDERS ----- D & RGW
	RUNNING BOARDS ----- U.S. GYPSUM CO.-STEEL	

REISSUE
 JAN. 2, 1960.
 JAN. 2, 1963.
 JAN. 2, 1965.

DENVER & RIO GRANDE WESTERN R.R.
 GONDOLA - FLAT BOTTOM - MILL TYPE CARS No's. 30000 to 30049
 AAR MECHANICAL DESIGNATION = GB

F-70

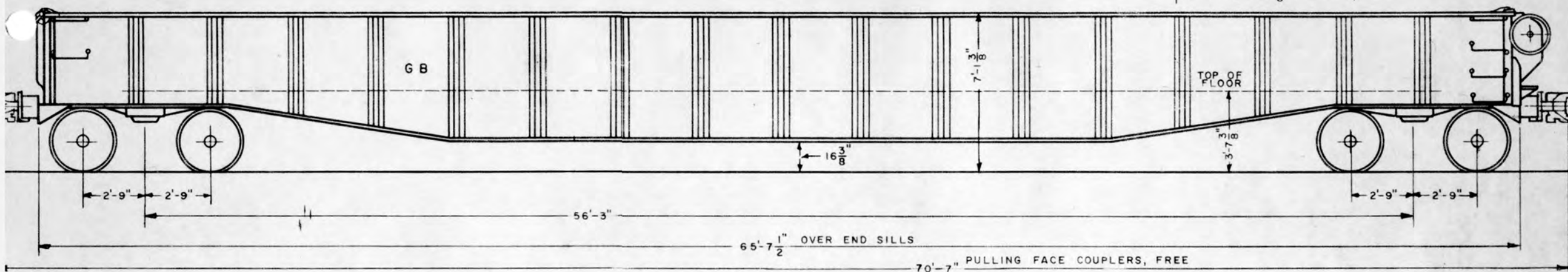
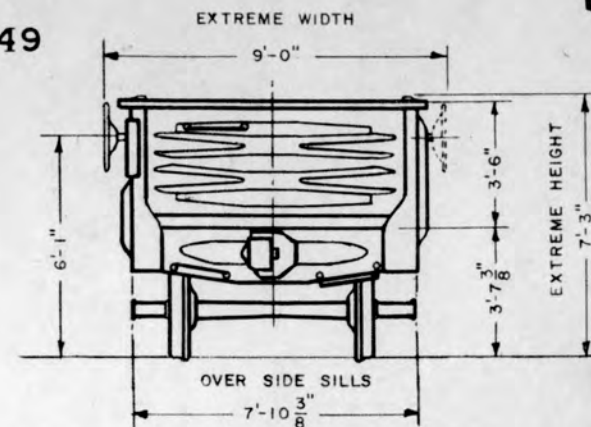

DESCRIPTION

GAUGE	4'-8 1/2"	SUPERSTRUCTURE	STEEL	MARKED CAPACITY, LBS.	154,000
JOURNALS	6" X 11"	ENDS - DROP	DREADNAUGHT 1-PIECE	LIGHT WEIGHT, LBS., AV.	58,100
WHEELS	33" WROT STEEL 1-W	UNDERFRAME	STEEL - DURYEA	MAX. WEIGHT OF LADING, LBS., AV.	161,900
TRUCK TYPE	BARBER STABILIZED-SPRING PLANK	DROP END FIXTURES	WINE	CUBICAL CAPACITY (LEVEL) CU. FT.	1763
TRUCK SIDES	CAST STEEL-INTEGRAL BOXES	DRAFT GEAR	DURYEA	CUBICAL CAPACITY (HEAPED) CU. FT.	2181
TRUCK BOLSTER	CAST STEEL	COUPLER	AAR TYPE E	LENGTH INSIDE	65'-0"
SIDE BEARINGS	BARBER	BRAKE	AB	WIDTH INSIDE	7'-9"
		HAND BRAKE	AJAX	DEPTH INSIDE	3'-6"
		BRAKE SLACK ADJUSTER	ROYAL TYPE F	YEAR BUILT	1939
				BUILDERS	PRESSED STEEL CAR CO.

REISSUE
 JAN. 2, 1961.
 JAN. 2, 1963.
 JAN. 2, 1965.

DENVER & RIO GRANDE WESTERN R.R.
 GONDOLA-FLAT BOTTOM-MILL TYPE CARS No's. 30050 to 30099

F-71

AAR MECHANICAL DESIGNATION = GB

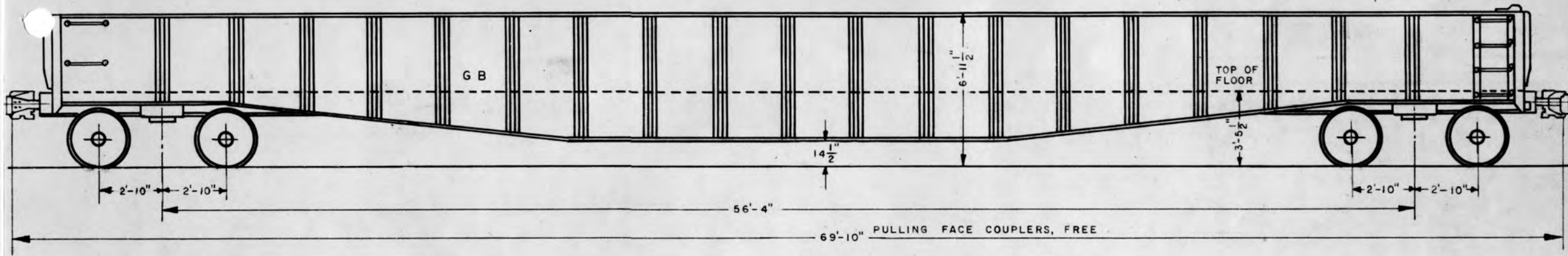
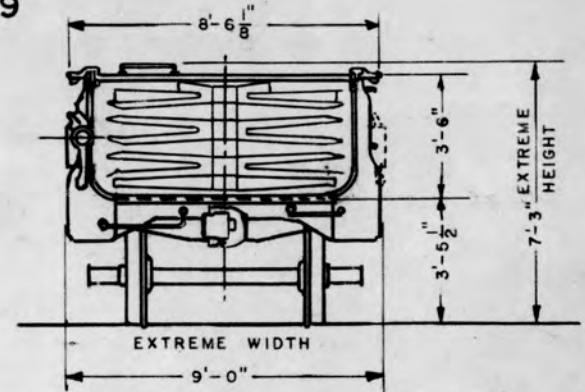

DESCRIPTION

GAUGE -----	4'-8 1/2"	SUPERSTRUCTURE -----	STEEL	MARKED CAPACITY, LBS. -----	154,000
JOURNALS -----	6" X 11"	ENDS - DROP -----	DREADNAUGHT 1-PIECE	LIGHT WEIGHT, LBS., AV. -----	59,000
WHEELS -----	33" WROT STEEL 1-W	UNDERFRAME -----	STEEL	MAX. WEIGHT OF LADING, LBS., AV. -----	161,000
TRUCK TYPE -----	BARBER STABILIZED, 2 1/2" SPRING TRAVEL	DROP-END FIXTURES -----	WINE	CUBICAL CAPACITY (LEVEL) CU. FT. -----	1777
TRUCK SIDES -----	CAST STEEL - INTEGRAL BOXES	DRAFT GEAR -----	MINER A-22-XB	CUBICAL CAPACITY (HEAPED) CU. FT. -----	2196
TRUCK BOLSTER -----	CAST STEEL	COUPLER -----	AAR TYPE E	LENGTH INSIDE -----	65'-6"
SIDE BEARINGS -----	STUCKI	BRAKE -----	AB	WIDTH INSIDE -----	7'-9"
UNIT TYPE BRAKE BEAMS -----	ASF	HAND BRAKE -----	UNIVERSAL PUMP HANDLE	DEPTH INSIDE -----	3'-6"
		BRAKE SLACK ADJUSTER -----	ROYAL TYPE F		
				YEAR BUILT -----	1948
				BUILDERS -----	PRESSED STEEL CAR CO.

REISSUE
 JAN. 2, 1962.
 JAN. 2, 1963.
 JAN. 2, 1965.

F-72

DENVER & RIO GRANDE WESTERN R.R.
 GONDOLA-FLAT BOTTOM-MILL TYPE CARS No's. 30100 to 30149

AAR MECHANICAL DESIGNATION = GB

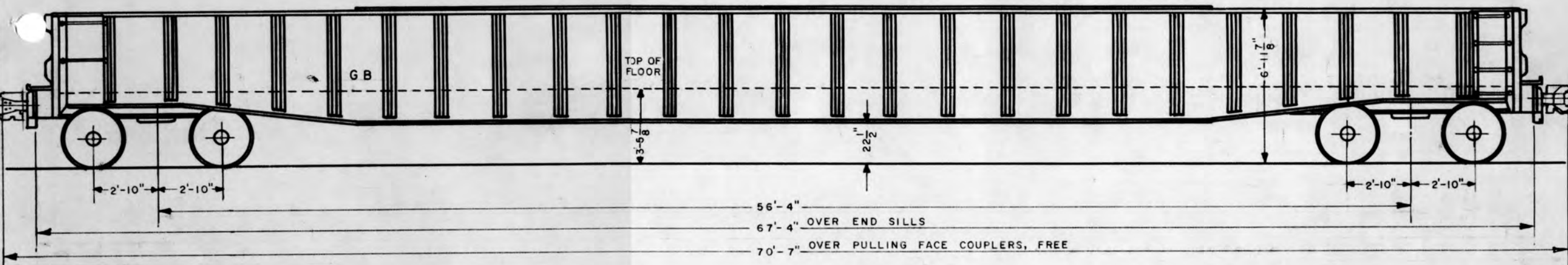
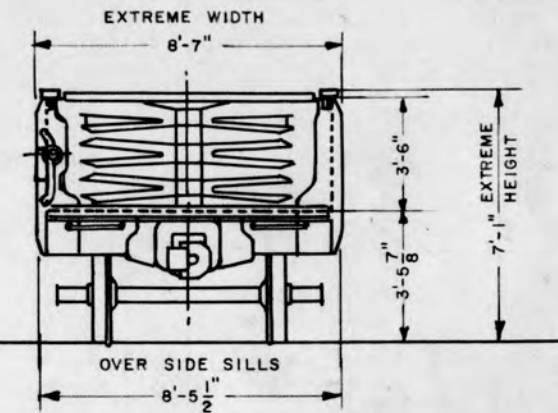

DESCRIPTION

GAUGE ----- 4'-8 1/2"	SUPERSTRUCTURE ----- STEEL	MARKED CAPACITY, LBS. ----- 154,000
JOURNALS ----- 6" X 11"	ENDS-DROP ----- DREADNAUGHT 1-PIECE	LIGHT WEIGHT, LBS., AV. ----- 64,200
WHEELS ----- 33" WROT STEEL 1-W	UNDERFRAME ----- STEEL	MAX. WEIGHT OF LADING, LBS., AV. ----- 155,800
TRUCK TYPE ----- BARBER STABILIZED	DROP-END FIXTURES ----- WINE	CUBICAL CAPACITY (LEVEL), CU. FT. ----- 1,774
SPRING TRAVEL ----- 2 1/2"	DRAFT GEAR ----- CARDWELL-WESTINGHOUSE NY-II-F	CUBICAL CAPACITY (HEAPED), CU. FT. ----- 2,192
TRUCK SIDES ----- CAST STEEL - INTEGRAL BOXES	COUPLER ----- (SWIVEL SHANK) AAR TYPE E	LENGTH INSIDE ----- 65'-6"
TRUCK BOLSTER ----- (SYMINGTON-GOULD) CAST STEEL	BRAKE ----- AB	WIDTH INSIDE ----- 7'-8 7/8"
SIDE BEARINGS ----- STUCKI	HAND BRAKE ----- EQUIPCO	DEPTH INSIDE ----- 3'-6"
UNIT TYPE BRAKE BEAMS ----- ASF		
		YEAR BUILT ----- 1949
		BUILDERS ----- BETHLEHEM STEEL CO.

DENVER & RIO GRANDE WESTERN R.R.
GONDOLA-FLAT BOTTOM-MILL TYPE CARS No's. 30150 to 30219

AAR MECHANICAL DESIGNATION = GB

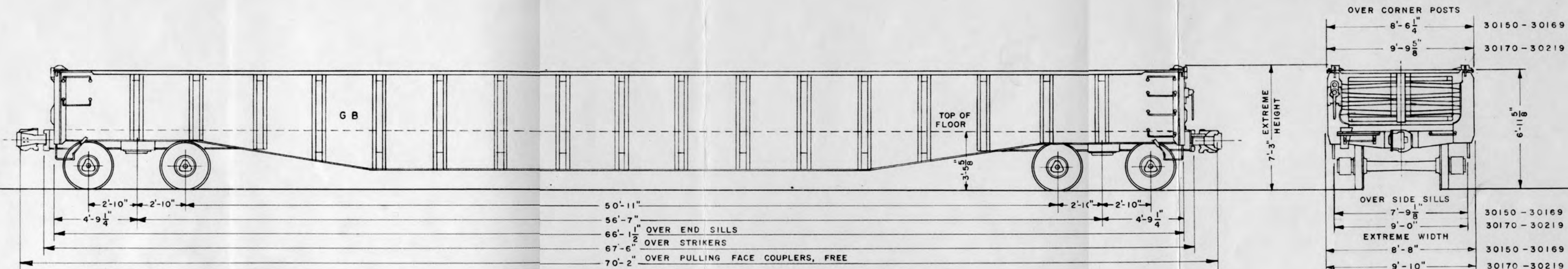

DESCRIPTION

GAUGE	4'-8 1/2"
JOURNALS (30150-30169)	6" X 11" TIMKEN ROLLER BEARINGS
JOURNALS (30170-30219)	6" X 11" HYATT ROLLER BEARINGS
WHEELS	(J 33) 33" WROT STEEL 1-W
AXLES (30150-30169)	D-11-65
AXLES (30170-30219)	D-11-66
TRUCK TYPE	ASF A-3 RIDE CONTROL, 2 1/2 SPRING TRAVEL
TRUCK SIDES	NARROW PEDESTAL TYPE
SIDE BEARINGS	STUCKI SINGLE ROLLER
BRAKE BEAMS (30150-30169)	BUFFALO-UNIT TYPE NO. 18
BRAKE BEAMS (30170-30219)	WABCOPAC B-3
BRAKE SHOES (30150-30169)	AAR 1A
BRAKE SHOES (30170-30219)	COBRA V-141

SUPERSTRUCTURE	STEEL
ENDS-DROP	STANDARD RAILWAY EQUIPMENT CO.-DREADNAUGHT 1-PIECE
DROP-END FIXTURES	WINE
UNDERFRAME	FABRICATED-STEEL
DRAFT GEAR (30150-30169, 30195-30219)	CARD-WESTINGHOUSE-MARK 50
DRAFT GEAR (30170-30194)	MINER TYPE RF-361
COUPLER	6 1/4 X 8" X 21 1/2" SHANK, AAR TYPE E
BRAKE (30150-30169)	WESTINGHOUSE ABC-1
BRAKE (30170-30219)	WABCOPAC B-3 WITH 8 1/2" DIA. CYLINDER AND A-1 REDUCTION RELAY VALVE-ABD-1
BRAKE CYLINDER RELEASE VALVE (30150-30169)	QRB
BRAKE SLACK ADJUSTER (30150-30169)	ELLCON NATIONAL-TYPE 1340
HAND BRAKE	LEVER TYPE-PEACOCK MODEL 1260-1
BRAKE STEPS	MORTON OPEN GRIP TYPE

MARKED CAPACITY, LBS.	154,000
LIGHT WEIGHT, LBS., AV. (30150-30169)	61,500
MAXIMUM WEIGHT OF LADING, LBS., AV. (30150-30169)	158,500
LIGHT WEIGHT, LBS., AV. (30170-30219)	62,000
MAXIMUM WEIGHT OF LADING, LB., AV. (30170-30219)	158,000
CUBICAL CAPACITY (LEVEL) CU. FT. (30150-30169)	1778
CUBICAL CAPACITY (HEAPED) CU. FT. (30150-30169)	2196
CUBICAL CAPACITY (LEVEL) CU. FT. (30170-30219)	2063
CUBICAL CAPACITY (HEAPED) CU. FT. (30170-30219)	2554
LENGTH INSIDE	65'-6"
WIDTH INSIDE (30150-30169)	7'-9"
WIDTH INSIDE (30170-30219)	9'-0"
DEPTH INSIDE	3'-6"
END DOOR OPENINGS (30150-30169)	"A" END 7'-1", "B" END 7'-0"
END DOOR OPENINGS (30170-30219)	"A" END 8'-4", "B" END 8'-2"
YEAR BUILT	30150-30169 IN 1965, 30170-30219 IN 1967
BUILDER	BETHLEHEM STEEL CO.

DENVER & RIO GRANDE WESTERN R.R.
 GONDOLA-FLAT BOTTOM-MILL TYPE CARS No's. 30220 TO 30244

AAR MECHANICAL DESIGNATION = GB

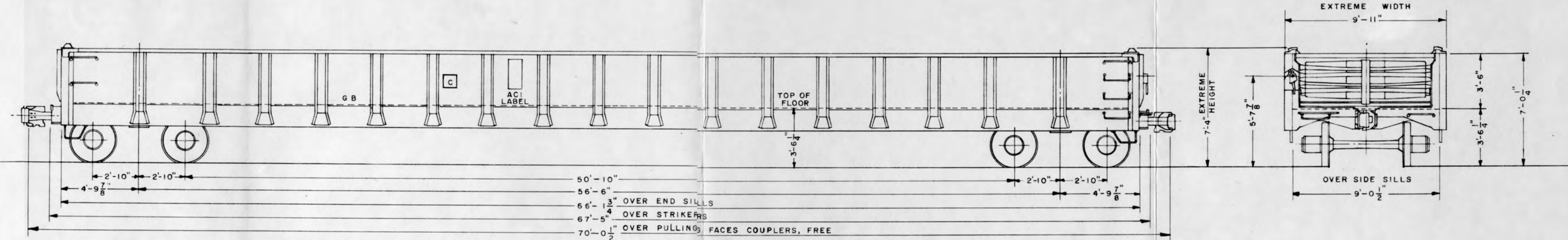

DESCRIPTION		
GAUGE	4'-8 1/2"	
JOURNALS	6" X 11" TIMKEN ROLLER BEARINGS	
WHEELS (J-33)	33" WROT STEEL 1-W	
AXLES	D-11-67	
TRUCK TYPE	ASF A-3 RIDE CONTROL, 2 1/2" SPRING TRAVEL	
TRUCK SIDES	NARROW PEDESTAL TYPE	
SIDE BEARINGS	STUCKI SINGLE ROLLER	
BRAKE BEAMS	WABCOPAC B-3	
BRAKE SHOES	COMPOSITION-COBRA V-141	
SUPERSTRUCTURE	FABRICATED-STEEL	
ENDS-DROP	STANDARD RAILWAY EQUIPMENT CO.-DREADNAUGHT 1-PIECE	
END DOOR CLEAR OPENING	8'-1"	
DROP END FIXTURES	WINE	
FLOOR	3/8" COPPER BEARING STEEL PLATE	
UNDERFRAME	AAR CENTER SILL AT 41.2 LBS., FABRICATED-STEEL	
DRAFT GEAR	MINER-TYPE RF-361	
COUPLER	(BE-60A-HT) 6 1/4" X 8" SHANK, TYPE E HEAD	
BRAKE-WABCOPAC B-3	6 1/2" DIA. CYLINDER AND A-1 REDUCTION RELAY VALVE-ABD-1	
HAND BRAKE	MINER-LEVER TYPE MODEL NO. 6600	
BRAKE STEP	APEX TRI-LOCK-TYPE A	
MARKED CAPACITY, LBS.	154,000	
LIGHT WEIGHT, LBS., AV. (ESTIMATED)	63,800	
MAXIMUM WEIGHT OF LADING, LBS., AV. (ESTIMATED)	156,200	
CUBICAL CAPACITY, CU. FT.	2060	
LENGTH INSIDE	65'-6"	
WIDTH INSIDE	9'-0"	
DEPTH INSIDE	3'-6"	
YEAR BUILT	1968	
BUILDER	THE DARBY CORPORATION	

DENVER & RIO GRANDE WESTERN R.R.
 GONDOLA-FLAT BOTTOM-MILL TYPE CARS No's. 30800 TO 30824

AAR MECHANICAL DESIGNATION = GB

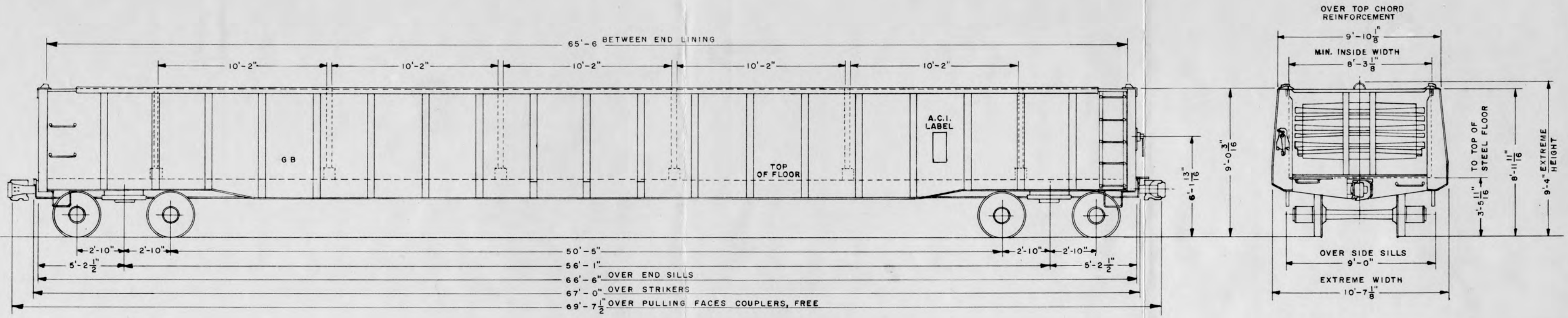

DESCRIPTION

GAUGE ----- 4'-8 1/2"	SUPERSTRUCTURE ----- FABRICATED-STEEL	MARKED CAPACITY, LBS. ----- 148,000
JOURNALS ----- 6" X 11" TIMKEN ROLLER BEARINGS	ENDS-DROP ----- STANDARD RAILWAY EQUIPMENT CO.- DREADNAUGHT 1-PIECE	LIGHT WEIGHT, LBS., AV. ----- 71,600
WHEELS (CJ-33) ----- 33" CAST TEEL 1-W	DROP END FIXTURES ----- WINE	MAXIMUM WEIGHT OF LADING, LBS., AV. ----- 148,400
AXLES ----- D-11-67	END LINING ----- 2" OAK	CUBICAL CAPACITY, CU. FT. ----- 2950
TRUCK TYPE ----- ASF A-3 RIDE CONTROL, 2 1/2" SPRING TRAVEL	FLOOR ----- 3/8" STEEL PLATE	LENGTH INSIDE ----- 65'-6"
TRUCK SIDES ----- NARROW PEDESTAL TYPE	UNDERFRAME ----- Z-26 CENTER SILL AT 41.2 LBS., FABRICATED-STEEL	WIDTH INSIDE ----- 9'-0"
SIDE BEARINGS ----- STUCKI SINGLE ROLLER	DRAFT GEAR ----- MINER - TYPE RF-361	DEPTH INSIDE ----- 5'-6"
BRAKE BEAMS ----- WABCOPAC B-3	COUPLER ----- (BE-60A-HT) 6 1/4" X 8" SHANK, TYPE E HEAD	YEAR BUILT ----- 1968
BRAKE SHOES ----- COMPOSITION - COBRA V-141	BRAKE ----- WABCOPAC B-3 - 8 1/2" DIA. CYLINDER AND A-1 REDUCTION RELAY VALVE-ABD-1	BUILDER ----- THRALL CAR MFG. CO.
LADING SEPARATORS ----- TWELVE 4" X 4" OAK POSTS AND SIX 8" X 8" OAK BEAMS	HAND BRAKE ----- LEVER TYPE - KLASING	
	BRAKE STEP ----- APEX TRI-LOCK - TYPE A	

DENVER & RIO GRANDE WESTERN R.R.

BALLAST CARS No.s 24800 to 25099

AAR MECHANICAL DESIGNATION = HK

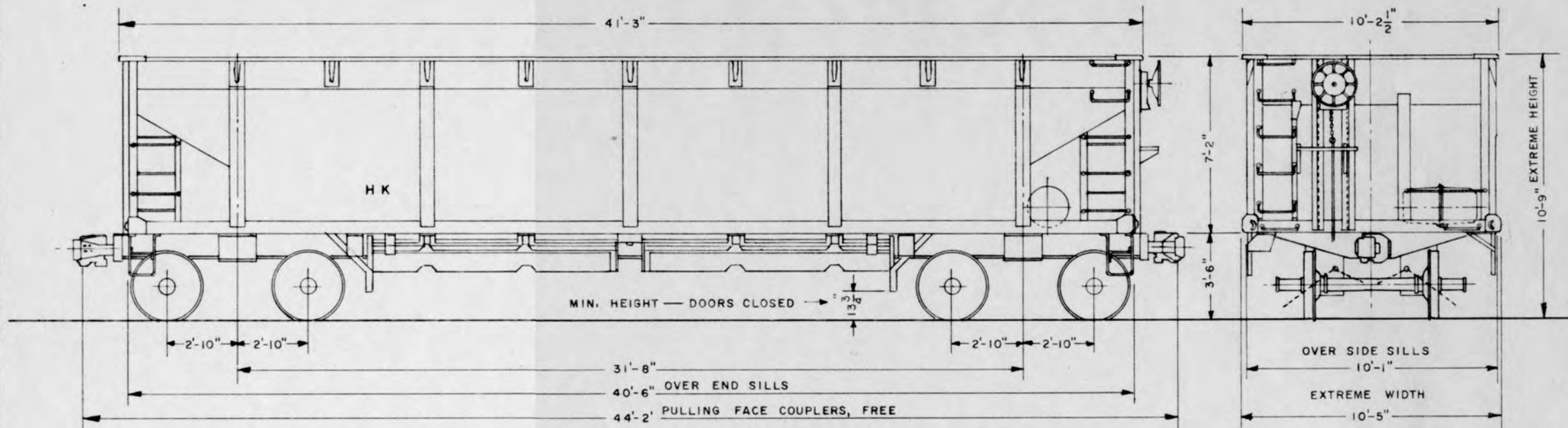

DESCRIPTION

GAUGE ----- 4'-8 1/2"	SUPERSTRUCTURE ----- 1/4" STEEL PLATE	MARKED CAPACITY, LBS. ----- 154,000
JOURNALS ----- 6" X 11"		LIGHT WEIGHT, LBS., AV. ----- 64,300
WHEELS ----- 33" MULTI-WEAR - ROLLED STEEL		MAX. WEIGHT OF LADING, LBS., AV. ----- 155,700
TRUCK TYPE ----- VULCAN- SPRING PLANK	UNDERFRAME ----- COPPER BEARING STEEL	
TRUCK SIDES ----- CAST STEEL - SEPARATE BOXES	DUMP RIGGING ----- RODGER BALLAST CAR CO.	CUBICAL CAPACITY, LEVEL, CU. FT. ----- 2519
TRUCK BOLSTER ----- ASF - CAST STEEL	DOORS- SIDE ----- CHAIN OPERATED	CUBICAL CAPACITY, HEAPED, CU. FT. ----- 2835
SIDE BEARINGS ----- STUCKI	DOORS- CENTER ----- WORM GEAR OPERATED	
	DRAFT GEAR (24800-24899) ___ CARD.- WEST. NY-II-F	LENGTH INSIDE ----- 40'-5"
BRAKE BEAMS (ORIGINALLY CRECO) ___ NO. 15	DRAFT GEAR (24900-24999) ___ MINER A-22-XB	WIDTH INSIDE ----- 10'-1"
BRAKE BEAMS - SOME HAVE ___ AAR NO. 18	DRAFT GEAR (25000-25099) ___ CARD.- WEST. NY-II-E	
	COUPLER ----- AAR TYPE E	
	BRAKE ----- ORIGINALLY AB-EMPTY & LOAD	YEAR BUILT (24800-24999) ----- 1946
	BRAKE ----- SOME HAVE AB 1012	YEAR BUILT (25000-25099) ----- 1937
	HAND BRAKE ----- AJAX	BUILDERS ----- AMERICAN CAR & FOUNDRY CO.
	BRAKE SLACK ADJUSTER ----- ROYAL TYPE F	RODGER ----- HART SELECTIVE BALLAST CAR

DENVER & RIO GRANDE WESTERN R.R.
 GONDOLA DUMP CARS No's. 46000 to 46499

AAR MECHANICAL DESIGNATION = GS

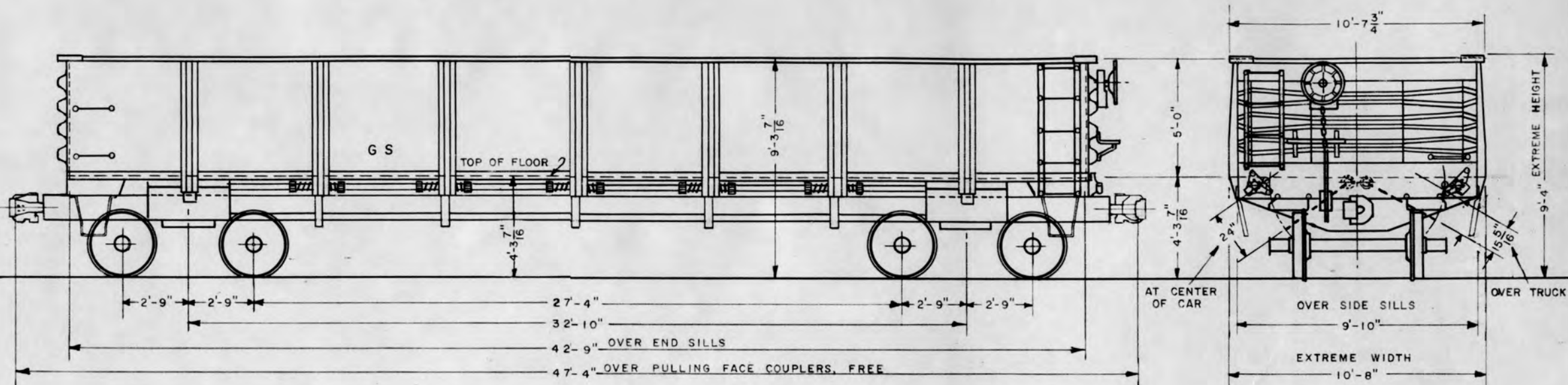

DESCRIPTION

GAUGE ----- 4'-8 1/2"
 JOURNALS ----- 5 1/2" X 10"
 WHEELS ----- 33" CAST IRON
 TRUCK TYPE ----- ASF A-3 RIDE CONTROL
 SPRING TRAVEL ----- 3 1/16"
 TRUCK SIDES ----- CAST STEEL- INTEGRAL BOXES
 TRUCK BOLSTER ----- CAST STEEL
 SIDE BEARINGS ----- STUCKI

ENDS ----- DREADNAUGHT 2-PIECE
 SIDES ----- STEEL
 UNDERFRAME ----- DURYEA
 DOORS ----- 16- CORRUGATED STEEL
 DOOR FIXTURES ----- CREEPING SHAFT TYPE

DRAFT GEAR ----- DURYEA
 COUPLER ----- AAR TYPE E
 BRAKE ----- AB
 HAND BRAKE (46000-46249) ----- AJAX
 HAND BRAKE (46250 46499) ----- UNIVERSAL
 BRAKE SLACK ADJUSTER ----- ROYAL TYPE F

MARKED CAPACITY, LBS. ----- 100,000
 LIGHT WEIGHT, LBS., AV. ----- 50,300
 MAX. WEIGHT OF LADING, LBS., AV. ----- 126,700
 CUBICAL CAPACITY, LEVEL, CU. FT. ----- 2,100
 CUBICAL CAPACITY, HEAPED, CU. FT. ----- 2,520

LENGTH INSIDE ----- 42'-9"
 WIDTH INSIDE ----- 9'-10"
 DEPTH INSIDE ----- 5'-0"

YEAR BUILT ----- 1947, 1948
 BUILDERS ----- PRESSED STEEL CO.

REISSUE
 JAN. 2, 1962.
 JAN. 2, 1963.
 JAN. 2, 1965.
 JAN. 2, 1968.

DENVER & RIO GRANDE WESTERN R.R.
 GONDOLA DUMP CARS No's. 46500 to 46999

F-81

AAR MECHANICAL DESIGNATION = GS

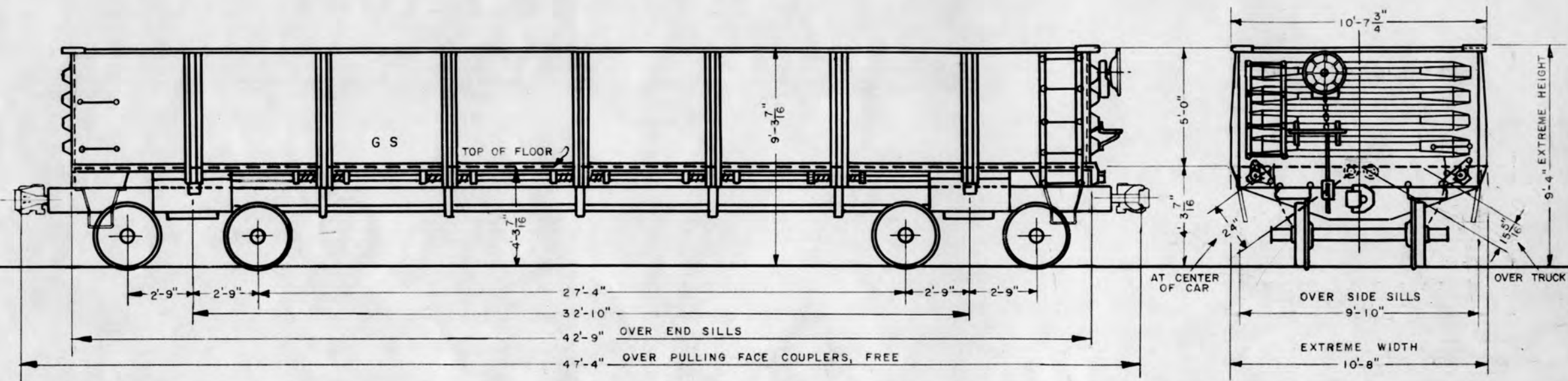

DESCRIPTION

GAUGE ----- 4'-8 1/2"
 JOURNALS ----- 5 1/2" x 10"
 WHEELS ----- 33" WROT STEEL 1-W
 TRUCK TYPE ----- ASF A-3 RIDE CONTROL
 SPRING TRAVEL ----- 3 1/16"
 TRUCK SIDES ----- CAST STEEL - INTEGRAL BOXES
 TRUCK BOLSTER ----- CAST STEEL
 SIDE BEARINGS ----- STUCKI

ENDS ----- PRESSED STEEL CAR CO. 1-PIECE
 SIDES ----- STEEL
 UNDERFRAME ----- DURYEA
 DOORS ----- 16 - CORRUGATED STEEL
 DOOR FIXTURES ----- CREEPING SHAFT TYPE
 DRAFT GEAR ----- DURYEA
 COUPLER ----- AAR TYPE E
 BRAKE ----- AB
 HAND BRAKE (46500-46749) ----- AJAX
 HAND BRAKE (46750-46999) ----- UNIVERSAL
 BRAKE SLACK ADJUSTER ----- ROYAL TYPE F

MARKED CAPACITY, LBS. ----- 100,000
 LIGHT WEIGHT, LBS., AV. ----- 48,000
 MAX. WEIGHT OF LADING, LBS., AV. ----- 129,000
 CUBICAL CAPACITY, LEVEL, CU. FT. ----- 2,100
 CUBICAL CAPACITY, HEAPED, CU. FT. ----- 2,520

LENGTH INSIDE ----- 42'-9"
 WIDTH INSIDE ----- 9'-10"
 DEPTH INSIDE ----- 5'-0"

YEAR BUILT ----- 1948
 BUILDERS ----- PRESSED STEEL CAR CO.

REISSUE
 JAN. 2, 1957.
 JAN. 2, 1962
 JAN. 2, 1963,
 JAN. 2, 1965,
 JAN. 2, 1968.

DENVER & RIO GRANDE WESTERN R.R.
 GONDOLA DUMP CARS No's. 47000 to 47499

AAR MECHANICAL DESIGNATION = GS

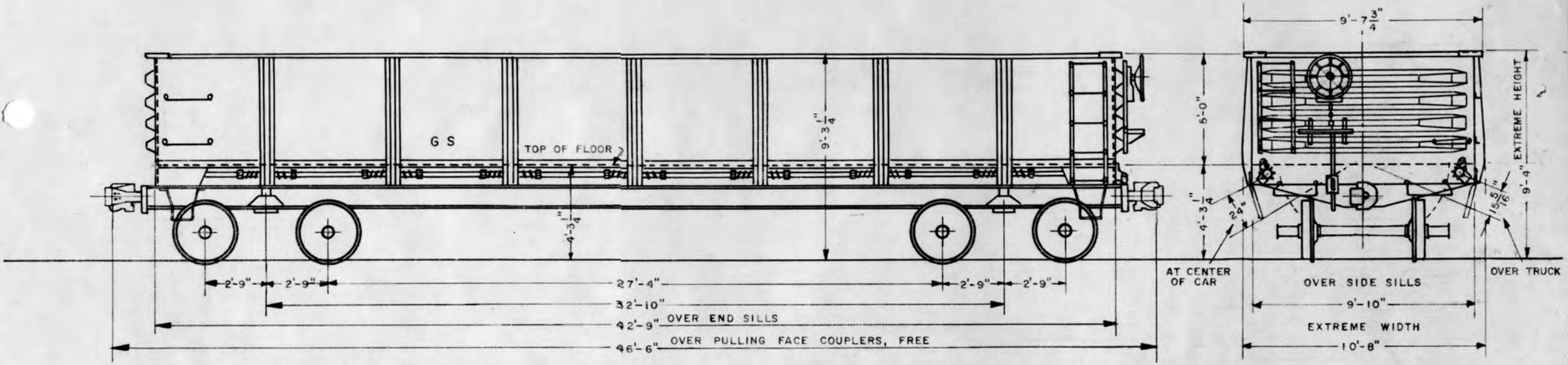

DESCRIPTION

GAUGE ----- 4'-8¹/₂"
 JOURNALS ----- 5¹/₂" X 10"
 WHEELS ----- 33" CAST IRON
 TRUCK TYPE ----- ASF A-3 RIDE CONTROL
 SPRING TRAVEL ----- 3¹/₁₆"
 TRUCK BOLSTER ----- CAST STEEL
 TRUCK SIDES ----- CAST STEEL-INTEGRAL BOXES
 SIDE BEARINGS ----- STUCKI

ENDS ----- PSC CO. 1-PIECE
 SIDES ----- STEEL
 UNDERFRAME ----- STEEL
 DOORS ----- 16- CORRUGATED STEEL
 DOOR FIXTURES ----- CREEPING SHAFT TYPE
 DRAFT GEAR ----- CARDWELL- WESTINGHOUSE NY II-F
 COUPLER ----- AAR TYPE E
 BRAKE ----- AB
 HAND BRAKE ----- AJAX
 BRAKE SLACK ADJUSTER ----- ROYAL TYPE F

MARKED CAPACITY, LBS. ----- 100,000
 LIGHT WEIGHT, LBS. ----- 47,800
 MAX. WEIGHT OF LADING, LBS. ----- 129,200
 CUBICAL CAPACITY, LEVEL, CU. FT. ----- 2,100
 CUBICAL CAPACITY, HEAPED, CU. FT. ----- 2,520
 LENGTH INSIDE ----- 42'-9"
 WIDTH INSIDE ----- 9'-10"
 DEPTH INSIDE ----- 5'-0"

YEAR BUILT ----- 1949
 BUILDERS ----- PRESSED STEEL CAR CO.

REISSUE
 JAN. 2, 1959.
 JAN. 2, 1962.
 JAN. 2, 1963.
 JAN. 2, 1965.

DENVER & RIO GRANDE WESTERN R.R.
 GONDOLA DUMP CARS No's. 71000 to 71999

AAR MECHANICAL DESIGNATION = GS

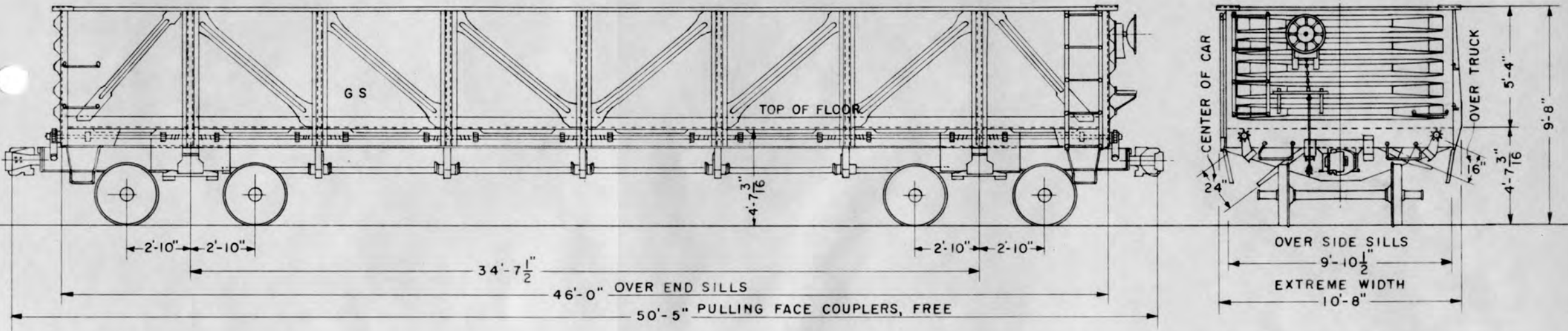

DESCRIPTION

GAUGE ----- 4'-8 1/2"
 JOURNALS ----- 6" X 11"
 WHEELS ----- 33" WROT STEEL I-W
 TRUCK TYPE ___ TRUCK ASSN.-FLAT COLUMN-SPRING PLANK
 TRUCK SIDES ----- CAST STEEL-INTEGRAL BOXES
 TRUCK BOLSTER ----- CAST STEEL
 SIDE BEARINGS ----- STUCKI
 SNUBBERS (71000-71527, 71778-71999)___CARDWELL-WEST.
 SNUBBERS (71528-71777) ----- HOLLAND

ENDS ----- STEEL
 SIDES ----- STEEL
 UNDERFRAME ----- STEEL-DURYEA
 DOORS ----- 16-CORRUGATED STEEL
 DOOR FIXTURES ----- CREEPING SHAFT TYPE
 DRAFT GEAR ----- DURYEA
 COUPLER ----- AAR TYPE E
 BRAKE ----- AB
 HAND BRAKE (71000-71799) ----- AJAX
 HAND BRAKE (71800-71999) ----- UNIVERSAL
 BRAKE GEAR REGULATOR ----- ROYAL TYPE F

MARKED CAPACITY, LBS. ----- 154,000
 LIGHT WEIGHT, LBS., AV. ----- 57,800
 MAX. WEIGHT OF LADING, LBS., AV. ----- 162,200
 CUBICAL CAPACITY, LEVEL, CU. FT. ----- 2410
 CUBICAL CAPACITY, HEAPED, CU. FT. ----- 2830
 LENGTH INSIDE ----- 46'-0"
 WIDTH INSIDE ----- 9'-10"
 DEPTH INSIDE ----- 5'-4"

YEAR BUILT ----- 1943
 BUILDERS ----- PRESSED STEEL CAR CO.
 REMODELED (STEEL SIDES APPLIED) ----- SINCE 1949

REISSUE
 SEPT. 1, 1959.
 JAN. 2, 1963.
 JAN. 2, 1965.

DENVER & RIO GRANDE WESTERN R. R.
 GONDOLA-FLAT BOTTOM CARS No's. 55001 to 55449
 (EXCEPT 59 CARS EQUIPPED FOR COIL STEEL LOADING AND 2 CARS EQUIPPED
 FOR PLATE GLASS LOADING)

AAR MECHANICAL DESIGNATION = GB

COIL STEEL CARS ON PAGE F-91
 NO'S. 55023 & 55373 ON PAGE F-92

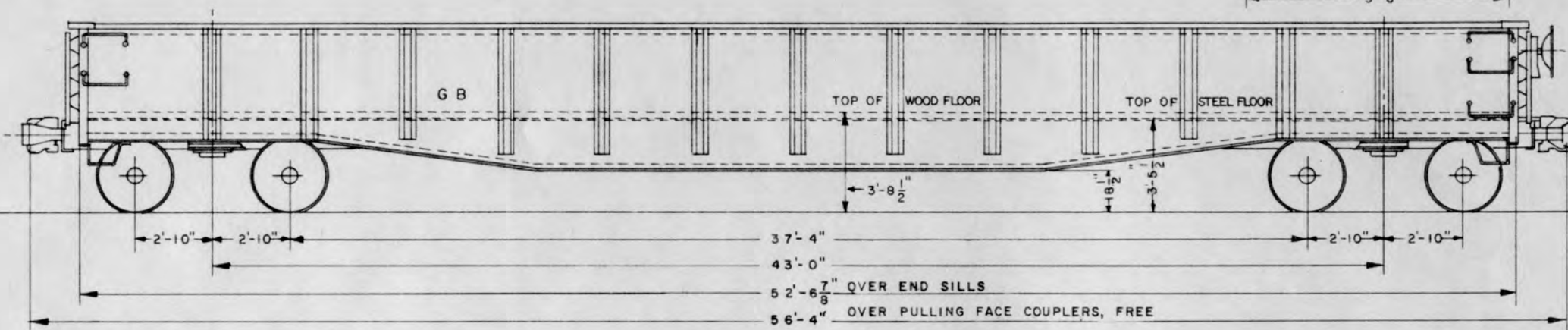
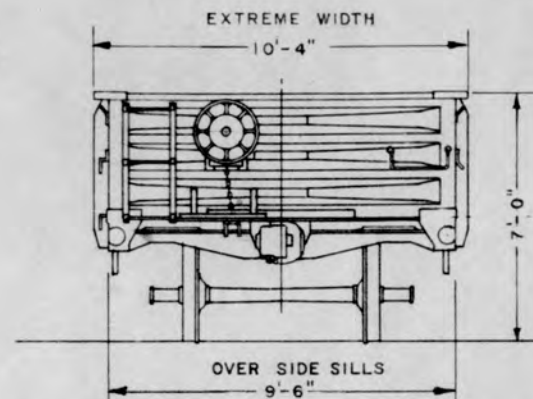

DESCRIPTION

GAUGE ----- 4'-8 1/2"	SUPERSTRUCTURE ----- STEEL	MARKED CAPACITY, LBS. ----- 154,000
JOURNALS ----- 6" X 11"	UNDERFRAME ----- STEEL	LT. WT., LBS., AV.-CARS WITHOUT WOOD FLOORS ----- 51,000
WHEELS ----- 33" WROT STEEL I-W	FLOOR (55049, 55123, 55138, 55203, 55243, 55254, 55288, 55303, 55341, 55449 ----- WOOD	MAX. WT. OF LADING, LBS., AV. ----- 169,000
TRUCK TYPE- { ASF A-3 RIDE CONTROL-SPRING PLANKLESS 2 1/2" SPRING TRAVEL	DRAFT GEAR (55001-55124) ----- MINER A-22-XB	LT. WT., LBS., AV.-10 CARS WITH WOOD FLOORS ----- 53,800
TRUCK SIDES ----- CAST STEEL-INTEGRAL BOXES	DRAFT GEAR (55250-55449) ----- MINER A-22-XB	MAX. WT. OF LADING, LBS., AV. ----- 166,200
TRUCK BOLSTER ----- CAST STEEL	DRAFT GEAR (55125-55249) ----- CARDWELL-WEST, NY-II-F	CU. CAP'Y., LEVEL, CU. FT. - WITHOUT WOOD FLOORS ----- 1745
SIDE BEARINGS ----- STUCKI	COUPLER ----- AAR TYPE E	CU. CAP'Y., HEAPED, CU. FT. - WITHOUT WOOD FLOORS ----- 2160
UNIT TYPE BRAKE BEAMS ----- UNIT TRUCK CORP. NO. 16	BRAKE ----- AB	CU. CAP'Y., LEVEL, CU. FT. - WITH WOOD FLOORS ----- 1621
	HAND BRAKE (55001-55249) ----- AJAX	CU. CAP'Y., HEAPED, CU. FT. - WITH WOOD FLOORS ----- 2063
	HAND BRAKE (55250-55449) ----- MINER	LENGTH INSIDE-ALL ----- 52'-6"
	BRAKE SLACK ADJUSTER ----- ROYAL TYPE F	WIDTH INSIDE-ALL ----- 9'-6"
		DEPTH INSIDE-CARS WITHOUT WOOD FLOORS ----- 3'-6"
		DEPTH INSIDE-CARS WITH WOOD FLOORS ----- 3'-3"
		YEAR BUILT (55001-55249) ----- 1948
		YEAR BUILT (55250-55449) ----- 1949
		BUILDERS ----- PULLMAN STANDARD CAR MFG. CO.
		WOOD FLOORS APPLIED TO 10 CARS ----- 1964

DENVER & RIO GRANDE WESTERN R.R.
COMMERCIAL FRAME TRANSPORT FLAT CARS No's. 20011 to 20014
 AAR MECHANICAL DESIGNATION = FMS

F-91
30205

20011	FORMERLY	20002
20012	"	20000
20013	"	20004
20014	"	22267

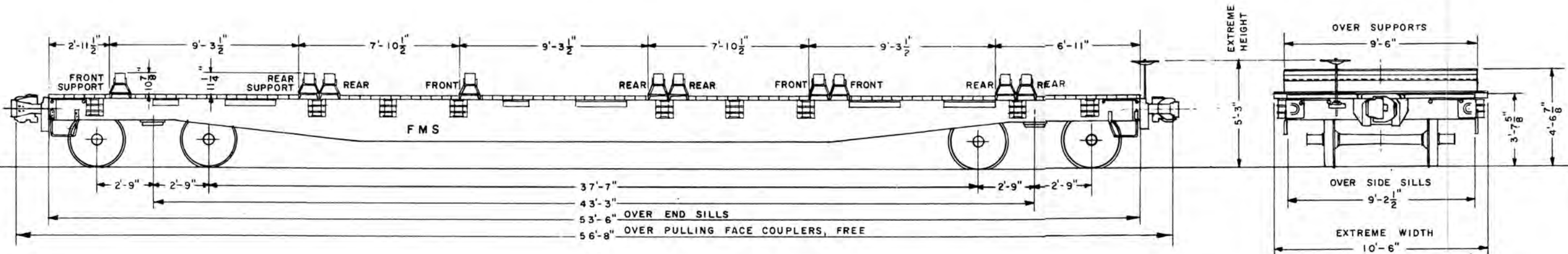

DESCRIPTION

GAUGE ----- 4'-8 1/2"
 JOURNALS ----- 5 1/2" X 10
 WHEELS ----- 33" STEEL 1-W
 TRUCK TYPE ----- TRUCK ASSOCIATION - SPRING PLANK
 SPRING TRAVEL ----- 2 1/2"
 TRUCK SIDES ----- CAST STEEL - INTEGRAL BOXES
 TRUCK BOLSTER ----- CAST STEEL
 SIDE BEARINGS ----- STUCKI

DECK ----- WOOD
 SUPPORT BEAMS ----- 10
 UNDERFRAME ----- STEEL
 DRAFT GEAR ----- CARDWELL - WESTINGHOUSE NY-II-F
 COUPLER ----- AAR TYPE E
 BRAKE ----- AB
 HAND BRAKE ----- UNIVERSAL DROP SHAFT
 BRAKE SLACK ADJUSTER ----- ROYAL TYPE F

MARKED CAPACITY, LBS. ----- 100,000
 LIGHT WEIGHT, LBS., AV. ----- 52,200
 MAX. WEIGHT OF LADING, LBS., AV. ----- 124,800

LENGTH OVER DECK ----- 53'-6"
 WIDTH OVER DECK ----- 10'-6"

YEAR BUILT AS FLAT CARS ----- 1944
 BUILDER ----- MT. VERNON CAR MFG. CO.
 REBUILT AS COMMERCIAL FRAME FLAT CARS BY D&RGW ----- 1962

REISSUE
 SEPT. 1, 1959.
 JAN. 2, 1960.
 JAN. 2, 1963.
 JAN. 2, 1965.

F-91

DENVER & RIO GRANDE WESTERN R.R.
 59 GONDOLA-FLAT BOTTOM CARS No's. C-55000 to C-55443
 EQUIPPED FOR COIL STEEL LOADING

AAR MECHANICAL DESIGNATION = GBS

C-55000	C-55114	C-55168		C-55309	C-55354
C-55003	C-55131	C-55182	C-55271	C-55317	C-55355
C-55021	C-55136	C-55186	C-55280	C-55323	C-55387
C-55027	C-55139	C-55188	C-55286	C-55328	C-55424
C-55033	C-55141	C-55191	C-55287	C-55330	C-55433
C-55039	C-55143	C-55199	C-55299	C-55342	C-55434
C-55061	C-55146	C-55218	C-55293	C-55343	C-55437
C-55066	C-55156	C-55223	C-55294	C-55348	C-55440
C-55071	C-55160	C-55232	C-55307	C-55350	C-55442
C-55100	C-55167	C-55258	C-55308	C-55351	C-55443

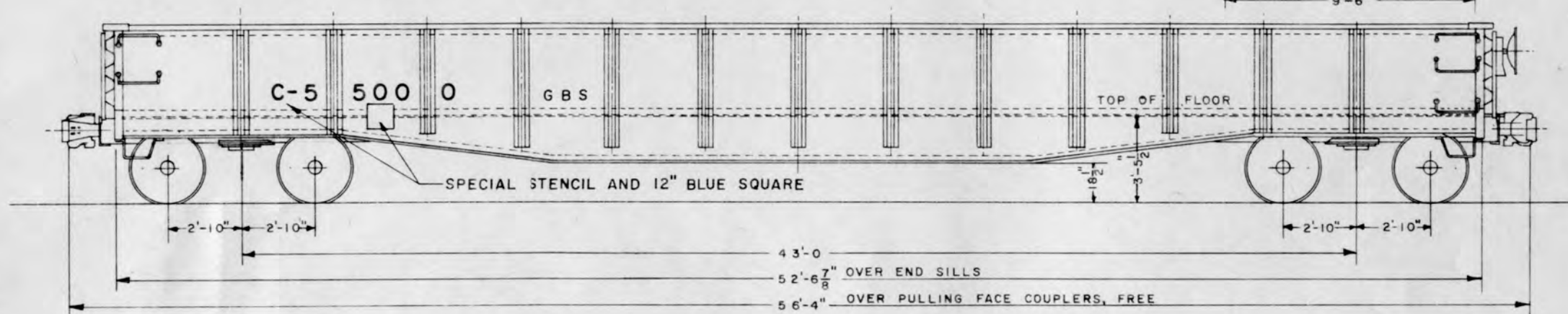
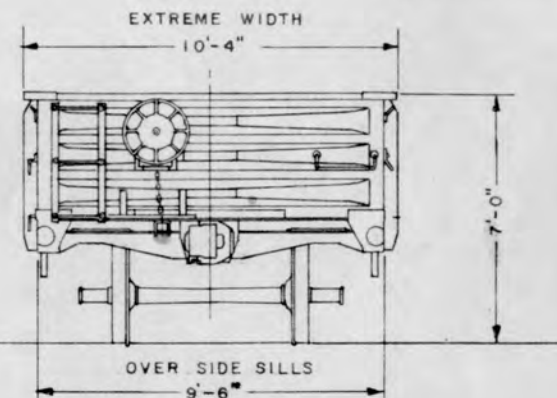

DESCRIPTION

GAUGE	4'-8 1/2"	SUPERSTRUCTURE	STEEL	MARKED CAPACITY, LBS.	154,000
JOURNALS	6" X 11"	UNDERFRAME	STEEL	LIGHT WEIGHT, LBS., AV.	54,800
WHEELS	33" WROT STEEL I-W			MAX. WEIGHT OF LADING, LBS., AV.	165,200
TRUCK TYPE	AS F A-3 RIDE CONTROL-SPRING PLANKLESS 2 1/2" SPRING TRAVEL				
TRUCK SIDES	CAST STEEL-INTEGRAL BOXES	DRAFT GEAR (C-55000-C-55114)	MINER A-22-XB	LENGTH INSIDE	52'-6"
TRUCK BOLSTER	CAST STEEL	DRAFT GEAR (C-55271-C-55443)	MINER A-22-XB	WIDTH INSIDE	9'-6"
SIDE BEARINGS	STUCKI	DRAFT GEAR (C-55131-C-55232)	CARDWELL-WEST, NY-II-F	DEPTH INSIDE	3'-6"
UNIT TYPE BRAKE BEAMS	UNIT TRUCK CORP. NO. 18	COUPLER	AAR TYPE E		
		BRAKE	AB	YEAR BUILT (C-55000-C-55232)	1948
		HAND BRAKE (C-55000-C-55114)	AJAX	YEAR BUILT (C-55271-C-55443)	1949
		HAND BRAKE (C-55271-C-55443)	MINER	BUILDERS	PULLMAN STANDARD CAR MFG. CO.
		BRAKE SLACK ADJUSTER	ROYAL TYPE F	COIL RACKS APPLIED TO 50 CARS	1957
				COIL RACKS APPLIED TO 10 CARS	1959

DENVER & RIO GRANDE WESTERN R.R.
GONDOLA-BULKHEAD CARS No's. 55023, 55373

F-92

AAR MECHANICAL DESIGNATION = GBS

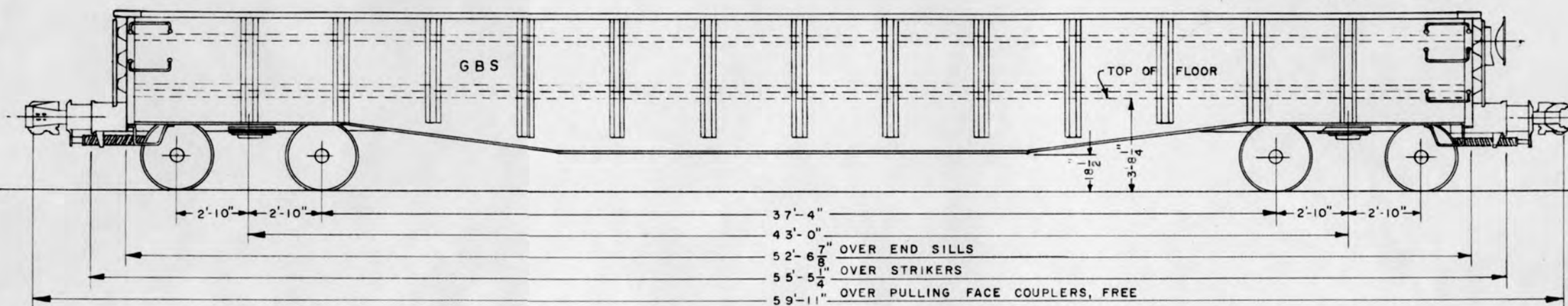
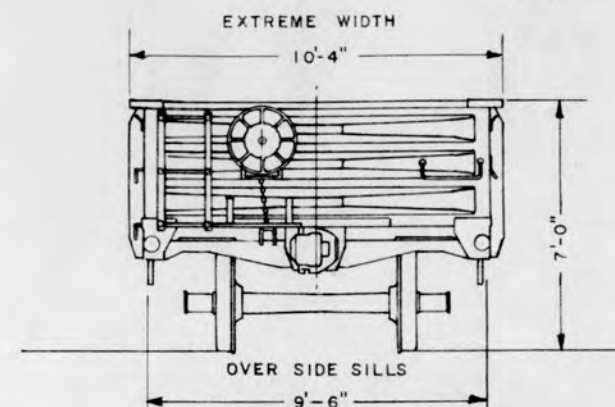

DESCRIPTION

GAUGE ----- 4-8 1/2"
 JOURNALS ----- 6" X 11"
 WHEELS ----- 33" WROT STEEL 1-W
 TRUCK TYPE ----- ASF A-3 RIDE CONTROL
 TRUCK SIDES ----- CAST STEEL- INTEGRAL BOXES
 SPRING TRAVEL ----- 2 1/2"
 SIDE BEARINGS ----- STUCKI
 UNIT TYPE BRAKE BEAMS ----- UNIT TRUCK CORR NO. 18

SUPERSTRUCTURE ----- STEEL
 FLOOR ----- 2 3/4" X 12" FIR PLANKS
 BULKHEADS ----- SHUNK MFG. CO.- 2
 SIDE ANGLES ----- SHUNK MFG. CO.- 4
 UNDERFRAME ----- STEEL
 DRAFT GEAR ----- FREIGHTMASTER CUSHION- 10" TRAVEL

COUPLER ----- AAR TYPE E
 BRAKE ----- AB
 HAND BRAKE - 55023 ----- AJAX
 HAND BRAKE - 55373 ----- MINER
 BRAKE SLACK ADJUSTER ----- ROYAL TYPE F

MARKED CAPACITY, LBS. ----- 154,000
 LIGHT WEIGHT LBS. ----- 58,000
 MAXIMUM WEIGHT OF LADING, LBS. ----- 162,000
 CUBICAL CAPACITY, CU. FT. ----- 1,624
 LENGTH INSIDE ----- 52'-6 7/8"
 WIDTH INSIDE ----- 9'- 6"
 WIDTH OVER BULKHEADS ----- 9'- 4"
 DEPTH INSIDE ----- 3'- 3 1/4"

YEAR BUILT - 55023 ----- 1948
 YEAR BUILT - 55373 ----- 1949
 BUILDERS ----- PULLMAN STANDARD CAR MFG. CO.
 BULKHEADS APPLIED ----- 1964

DENVER & RIO GRANDE WESTERN R.R.
 GONDOLA-FLAT BOTTOM CARS No's. 55500 TO 55549

AAR MECHANICAL DESIGNATION = GB

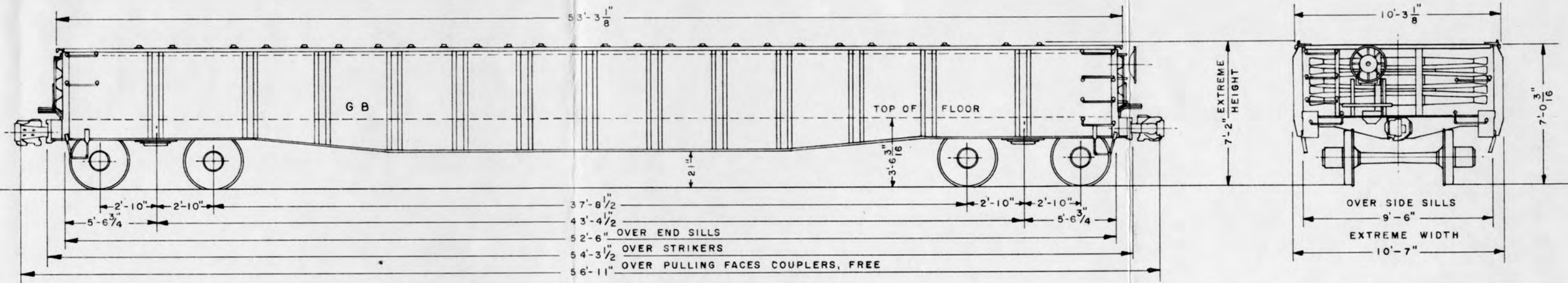

DESCRIPTION

GAUGE ----- 4'-8 1/2"
 JOURNALS ----- 6" X 11" HYATT ROLLER BEARINGS
 WHEELS ----- (J-33) 33" WROT STEEL 1-W
 AXLES ----- D-11-67
 TRUCK TYPE ----- ASF A-3 RIDE CONTROL, 2 1/2" SPRING TRAVEL
 TRUCK SIDES ----- NARROW PEDESTAL TYPE
 SIDE BEARINGS ----- STUCKI SINGLE ROLLER
 BRAKE BEAMS ----- WABCOPAC B3
 BRAKE SHOES ----- COBRA V-141

SUPERSTRUCTURE ----- STEEL
 ENDS-FIXED ----- STANDARD RAILWAY EQUIPMENT CO. DREADNAUGHT 1-PIECE
 FLOOR ----- 3/8" STEEL PLATE
 LADING BAND ANCHORS ----- 52
 UNDERFRAME ----- FABRICATED-STEEL
 DRAFT GEAR ----- NATIONAL STEEL CASTINGS CO, TYPE NC-440
 COUPLER ----- 6 1/4" X 8" X 2 1/2" SHANK, AAR TYPE E
 BRAKE - WABCOPAC B3, 8 1/2" DIA. CYLINDER ----- ABD
 HAND BRAKE ----- AJAX

MARKED CAPACITY, LBS. ----- 154,000
 LIGHT WEIGHT, LBS., AV. (ESTIMATED) ----- 56,200
 MAXIMUM WEIGHT OF LADING, LBS., AV. (ESTIMATED) ----- 163,800
 CUBICAL CAPACITY - LEVEL - CU. FT. ----- 1750
 CUBICAL CAPACITY - HEAPED ----- 2166
 LENGTH INSIDE ----- 52'-6"
 WIDTH INSIDE ----- 9'-6"
 DEPTH INSIDE ----- 3'-6"

BRAKE STEP ----- MORTON OPEN GRIP TYPE

YEAR BUILT ----- 1968
 BUILDER ----- BETHLEHEM STEEL CO.

DENVER & RIO GRANDE WESTERN R.R.
CHEVROLET FRAME TRANSPORT FLAT CARS No's. 20000 to 20006
AAR MECHANICAL DESIGNATION - FMS

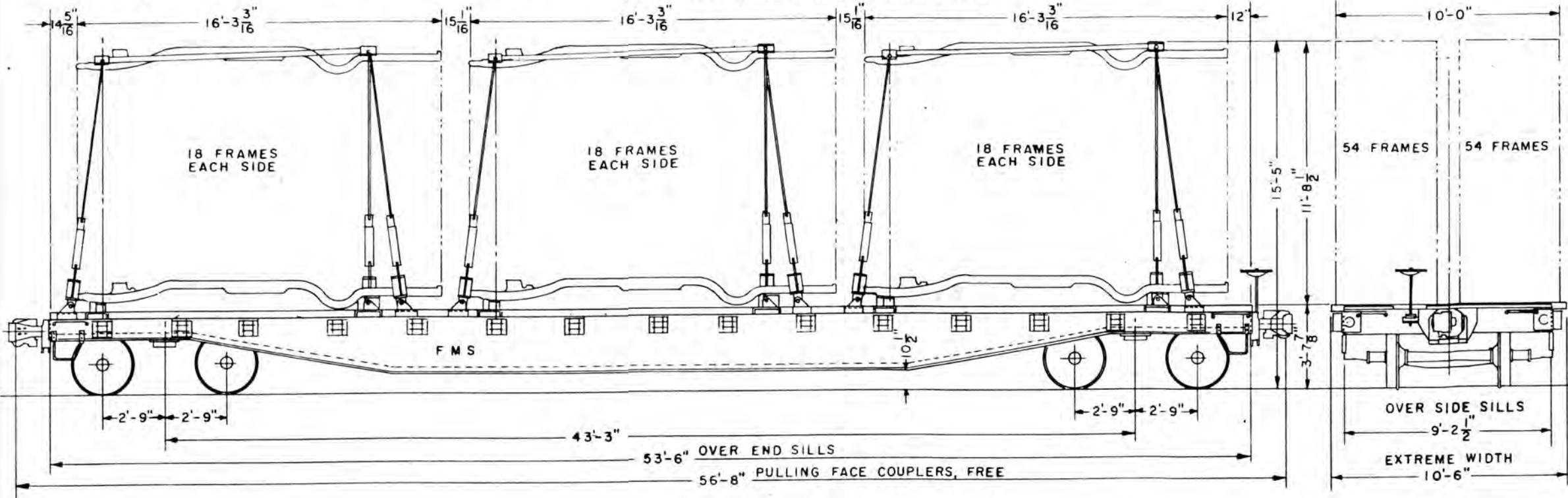

DESCRIPTION

GAUGE ----- 4'-8 1/2"
 JOURNALS ----- 5 1/2" x 10"
 WHEELS ----- 33" CAST IRON
 TRUCK TYPE ----- TRUCK ASSOCIATION-SPRING PLANK
 TRUCK SIDES ----- CAST STEEL-INTEGRAL BOXES
 TRUCK BOLSTER ----- CAST STEEL
 SIDE BEARINGS ----- STUCKI
 FRAME LOADING CAPACITY (6 STACKS OF 18) ----- TOTAL 108

20000	FORMERLY	22167
20001	"	22160
20002	"	22129
20003	"	22187
20004	"	22084
20005	"	22164
20006	"	22094

UNDERFRAME ----- STEEL
 DRAFT GEAR ----- CARDWELL-WESTINGHOUSE NY-11-F
 COUPLER ----- AAR TYPE E
 BRAKE ----- AB
 HAND BRAKE ----- UNIVERSAL DROP SHAFT
 BRAKE SLACK ADJUSTER ----- ROYAL TYPE F

MARKED CAPACITY, LBS. ----- 100,000
 LIGHT WEIGHT, LBS., AV. ----- 54,900
 MAX. WEIGHT OF LADING, LBS., AV. ----- 114,100
 LENGTH OVER DECKING ----- 53'-6"
 WIDTH OVER DECKING ----- 10'-6"

YEAR BUILT (AS FLAT CARS) ----- 1944
 BUILDERS ----- MT. VERNON CAR MFG CO.
 EQUIPPED FOR AUTO FRAME LOADING ----- 1957
 LOADING EQUIPMENT ----- PARAGON CONSTRUCTION CO.

DENVER & RIO GRANDE WESTERN R. R.
COVERED GONDOLA-FLAT BOTTOM CARS No's. 56000 to 56009

F-95

AAR MECHANICAL DESIGNATION = GBR

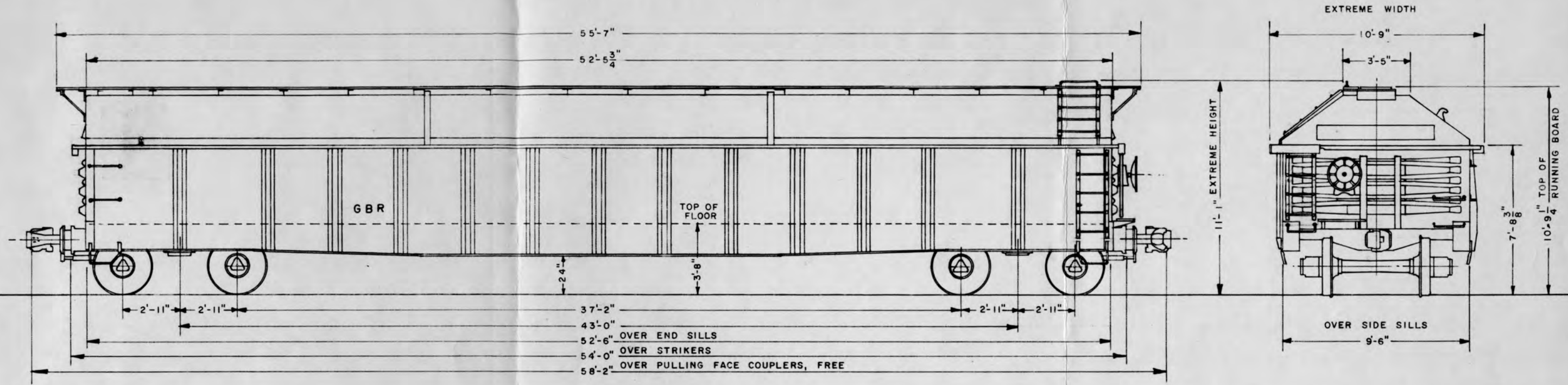

DESCRIPTION

GAUGE	4'-8 1/2"	ROOF - REMOVABLE	SHUNK MFG. CO.	MARKED CAPACITY, LBS.	180,000
JOURNALS	6 1/2" X 12" HYATT ROLLER BEARINGS - TYPE AP.	ENDS	STANRAY - CORRUGATED STEEL	LIGHT WEIGHT, LBS., AV.	75,600
WHEELS	36" CAST STEEL 2-W	SIDES	0.25" STEEL PLATE	MAX. WEIGHT OF LADING, LBS., AV.	187,400
AXLES	D-6-D	UNDERFRAME	STEEL	CUBICAL CAPACITY, CU. FT.	1780
SPRING TRAVEL	2 1/2"	FLOOR	2.25" HARDWOOD	LENGTH INSIDE - BETWEEN BULKHEADS	51'-4"
TRUCK TYPE	NATIONAL CASTINGS CO. - BARBER STABILIZED	BULKHEADS - SINGLE TRACK - TWO	YOCAR	WIDTH INSIDE - BETWEEN BULKHEAD LOCKING RAILS	8'-8"
TRUCK SIDES	NARROW PEDESTAL TYPE	LOCKING RAILS - FOUR	5" X 3" X 1/2" ANGLES	HEIGHT INSIDE - TOP OF FLOOR TO TOP OF BULB ANGLES	4'-0"
SIDE BEARINGS	STUCKI - ROLLER	DRAFT GEAR	FREIGHTMASTER - 10" - TYPE E	YEAR BUILT	1964
UNIT TYPE BRAKE BEAMS	APEX - BOXWELD NO. 24	COUPLER	AAR TYPE E	BUILDERS	GUNDERSON BROS. ENGINEERING CORP.
		BRAKE	NEW YORK AIR BRAKE CO. - AB 1210		
		BRAKE CYLINDER RELEASE VALVE	ORB		
		BRAKE SLACK ADJUSTER	ELLCON NATIONAL - TYPE 1340-3		
		HAND BRAKE	MINER		
		RUNNING BOARDS AND BRAKE STEP	APEX - STEEL		

DENVER & RIO GRANDE WESTERN R. R. GONDOLA - CAR No's. 56100-56124

AAR MECHANICAL DESIGNATION = GB

F - 96

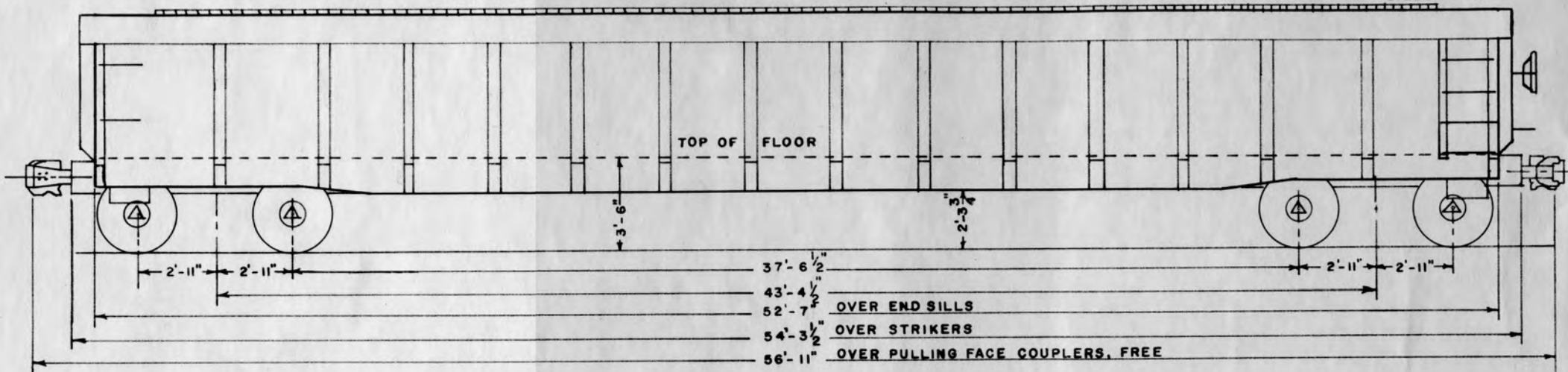
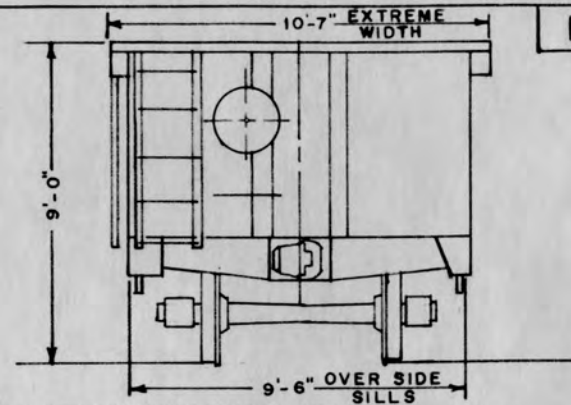

DESCRIPTION

GAUGE ----- 4'-8 1/2"
 JOURNALS ----- 6 1/2" X 12" BRENCO R.B.
 WHEELS ----- J-36 WROT STEEL 2-W
 TRUCK TYPE ----- 100 TON NARROW PEDESTAL
 SPRING TRAVEL ----- 3 11/16"
 SIDE BEARINGS ----- DOUBLE ROLLER STUCKI

SUPERSTRUCTURE ----- STEEL
 FLOOR ----- STEEL
 LADING BAND ANCHORS ----- 48'-CONTINUOUS
 UNDERFRAME ----- STEEL
 DRAFT GEAR ----- MINER RF-361
 COUPLER ----- TYPE-E
 BRAKE ----- WABCOPAC 8 1/2"
 HAND BRAKE ----- ELLCON NATIONAL

MARKED CAPACITY LBS. ----- 197,000
 LIGHT WEIGHT LBS. ----- 64,200
 MAXIMUM WEIGHT OF LADING, LBS. ----- 198,800
 CUBICAL CAPACITY, CU. FT. ----- 2750 CU. FT.
 LENGTH INSIDE ----- 52'-6"
 WIDTH INSIDE ----- 9'-6"
 DEPTH INSIDE ----- 5'-6"

YEAR BUILT ----- 1969
 BUILDERS ----- THRALL CAR MFG.

DENVER & RIO GRANDE WESTERN R.R.
 GONDOLA-CAR No's. 56995 to 56999
 AAR MECHANICAL DESIGNATION = GT

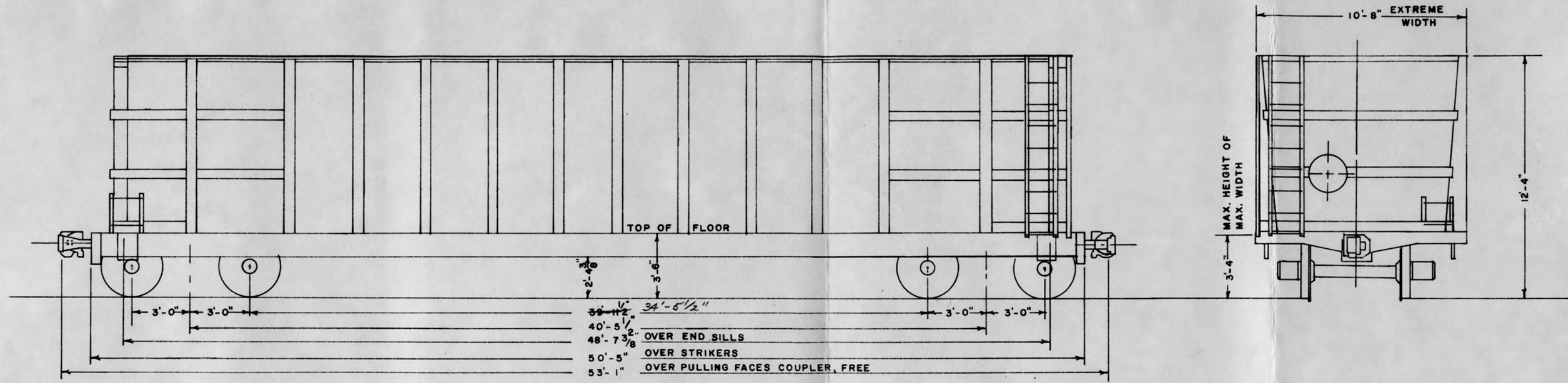

DESCRIPTION

GAUGE	4'-8 1/2"	SUPERSTRUCTURE	STEEL	MARKED CAPACITY, LBS.	200,000
JOURNALS	TIMKEN 7X12 RB.	UNDERFRAME	STEEL	LIGHT WEIGHT, LBS., AV.	65,200
WHEELS	38" 2W-WROT STEEL	FLOOR	STEEL	MAXIMUM WEIGHT OF LADING, LBS., AV.	249,800
AXLES	D11-68			CUBICAL CAPACITY, CU. FT.	3,850
TRUCK TYPE	125-TON	DRAFT GEAR	NATIONAL CASTING TYPE NC-440-1	LENGTH INSIDE	47'-0"
SIDE BEARINGS	DOUBLE-STUCKI	COUPLER	TYPE-E	WIDTH INSIDE	8'-9" TO 9'-10"
BRAKE BEAMS	CHICAGO	BRAKE	AB	DEPTH INSIDE	8'-10"
		HAND BRAKE	PEACOCK	YEAR BUILT	1969
				BUILDER	TRHALL CAR MFG. CO.

DENVER & RIO GRANDE WESTERN R.R.
QUADRUPLE HOPPER CARS No's. 16775 TO 16999

AAR MECHANICAL DESIGNATION = HT

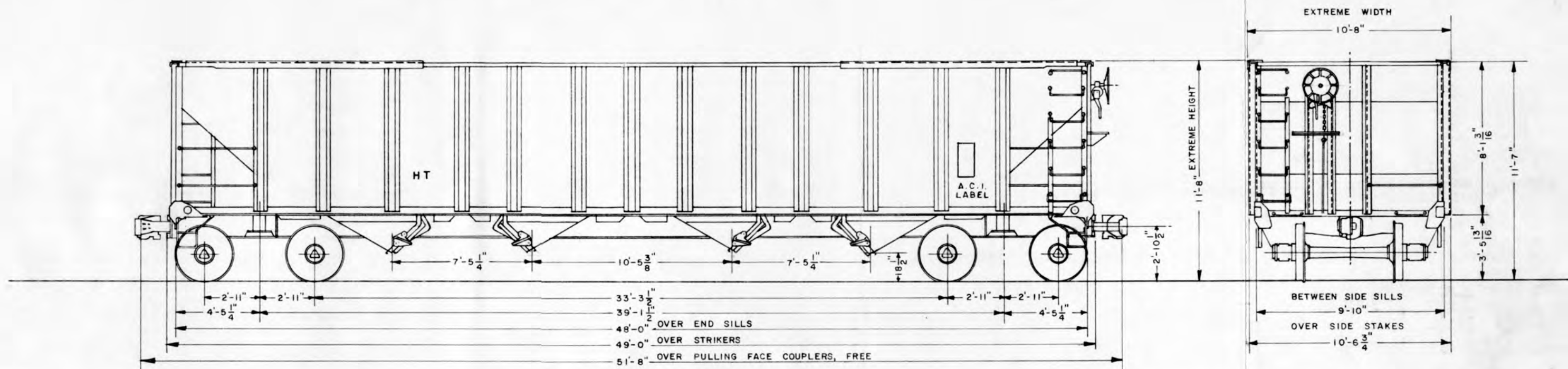

DESCRIPTION

GAUGE -----	4'-8 1/2"	SUPERSTRUCTURE -----	FABRICATED STEEL	MARKED CAPACITY, LBS. (16775-16874) -----	199,000
JOURNALS (16775-16874) -----	25 BRENCO, 75 HYATT -----	6 1/2" X 12" ROLLER BEARINGS		MARKED CAPACITY, LBS. (16875-16999) -----	200,000
JOURNALS (16875-16999) -----	6 1/2" X 12" TIMKEN ROLLER BEARINGS			LIGHT WEIGHT, LBS., AV. (16775-16874) -----	63,100
WHEELS (J-36) -----	36" WROT STEEL 2-W			LIGHT WEIGHT, LBS., AV. (16875-16999) -----	63,000
AXLES -----	D-11-7			MAXIMUM WEIGHT OF LADING, LBS., AV. (16775-16874) -----	199,900
TRUCK TYPE -----	ASF A-3 RIDE CONTROL, 3 1/16" SPRING TRAVEL			MAXIMUM WEIGHT OF LADING, LBS., AV. (16875-16999) -----	200,000
TRUCK SIDES -----	NARROW PEDESTAL TYPE			CUBICAL CAPACITY, CU. FT. (LEVEL) -----	3483
SIDE BEARINGS -----	STUCKI-DOUBLE ROLLER			CUBICAL CAPACITY, CU. FT. (HEAPED) -----	3874
BRAKE BEAMS (16775-16874) -----	DAVIS NO. 18			LENGTH INSIDE -----	47'-11 1/2"
BRAKE BEAMS (16875-16999) -----	DAVIS NO. 24			WIDTH INSIDE -----	9'-9 1/2"
BRAKE SHOES (16775-16874) -----	COMPOSITION - COMET H-4			YEAR BUILT -----	1968
BRAKE SHOES (16875-16999) -----	AAR ALTERNATE STANDARD, TYPE S			YEAR BUILT -----	1964
SWAY ARRESTORS (16825-16874) -----	FREIGHTMASTER			BUILDERS -----	BETHLEHEM STEEL CO.
		HAND BRAKE (16775-16874) -----	ELLCON NATIONAL MODEL NO. 1600-2		
		HAND BRAKE (16875-16999) -----	MINER MODEL NO. D-3290-XL		
		BRAKE STEP (16775-16874) -----	U.S. GYPSUM CO. TYPE 2600		
		BRAKE STEP (16875-16999) -----	APEX		

REISSUE
JAN. 2, 1953.
JAN. 2, 1959.

DENVER & RIO GRANDE WESTERN R.R.
BULKHEAD FLAT CARS

No's. 22240, 22241, 22242, 22245, 22246, 22249,
22254, 22256, 22257, 22258, 22260, 22261, 22263

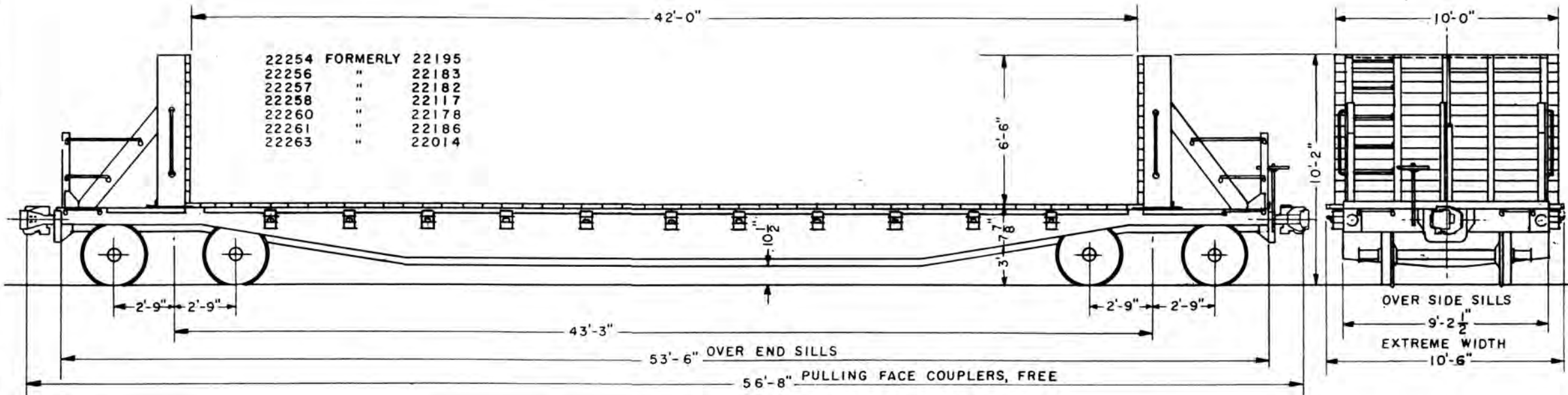

S H Coll.

DESCRIPTION

GAUGE ----- 4'-8 1/2" JOURNALS ----- 5 1/2" x 10" WHEELS ----- 33" CAST IRON	UNDERFRAME ----- STEEL	MARKED CAPACITY, LBS. ----- 100,000 LIGHT WEIGHT, LBS., AV. ----- 53,900 MAX. WEIGHT OF LADING, LBS., AV. ----- 115,100
TRUCK TYPE (22240-22249) { ASF A-3 RIDE CONTROL, SPRING PLANKLESS, 3/16" SPRING TRAVEL	DRAFT GEAR ----- CARDWELL-WESTINGHOUSE NY-II-F COUPLER ----- AAR TYPE E BRAKE ----- AB HAND BRAKE ----- UNIVERSAL-DROP SHAFT	LENGTH OVER DECKING ----- 42'-0" WIDTH OVER DECKING ----- 10'-6"
TRUCK TYPE (22254-22263) { TRUCK ASSOCIATION, SPRING PLANK	BRAKE SLACK ADJUSTER (22240-22249) ----- PNEUMATIC-AJAX BRAKE SLACK ADJUSTER (22254-22263) ----- ROYAL TYPE F	YEAR BUILT AS FLAT CARS (22240-22249) ----- 1951 YEAR BUILT AS FLAT CARS (22254-22263) ----- 1944
TRUCK SIDES ----- CAST STEEL-INTEGRAL BOXES TRUCK BOLSTER ----- CAST STEEL SIDE BEARINGS ----- STUCKI	BUILDERS (22240-22249) ----- D & R G W BUILDERS (22254-22263) ----- MT. VERNON CAR MFG. CO.	REBUILT AS BULKHEAD FLAT CARS BY D & R G W ----- 1951, 1952

DENVER & RIO GRANDE WESTERN R.R.

HOPPER CARS No's. 14600 to 14999

F-109

AAR MECHANICAL DESIGNATION = HT

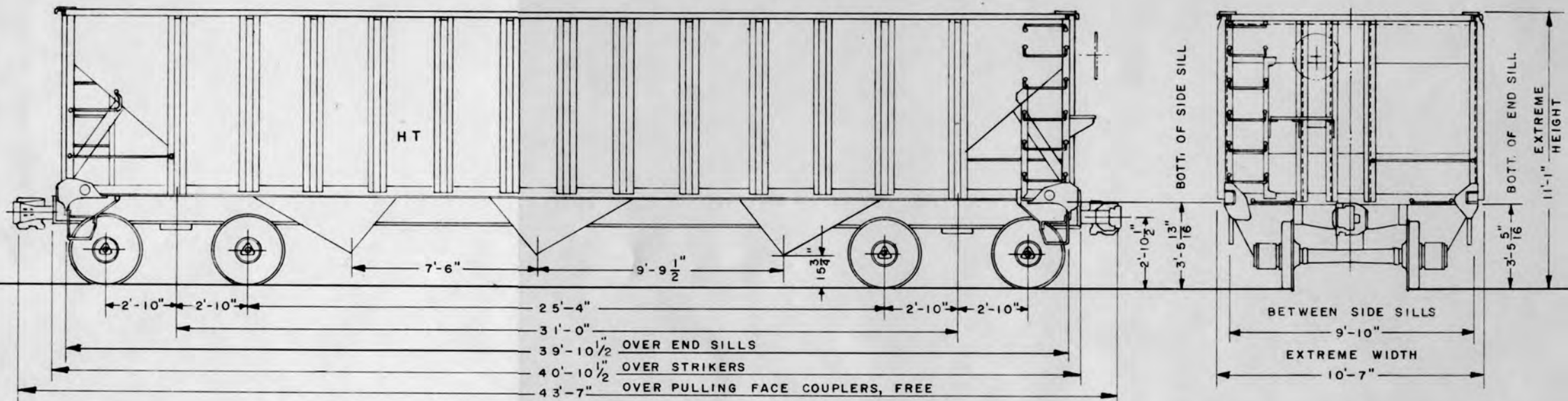

DESCRIPTION

GAUGE ----- 4'-8 1/2"

JOURNALS -14600-14949-6"X11" TIMKEN ROLLER BEARINGS

JOURNALS -14950-14999-6"X11" HYATT ROLLER BEARINGS

WHEELS ----- 33" WROT STEEL 2-W

AXLES ----- D-11-1965

TRUCK TYPE ----- ASF A-3 RIDE CONTROL

SPRING TRAVEL ----- 2 1/2"

TRUCK SIDES ----- NARROW PEDESTAL TYPE

SIDE BEARINGS ----- STUCKI-SINGLE ROLLER

BRAKE BEAMS ----- UNIT TYPE NO. 24

SUPERSTRUCTURE ----- STEEL

UNDERFRAME ----- STEEL

DOORS -6 (STAND. RWY EQUIP. CO.)-DREADNAUGHT 3/8" PLATE

DOOR FIXTURES ----- WINE

DOOR OPENINGS ----- 25 3/4" X 35 3/4"

DRAFT GEAR ----- CARDWELL-WESTINGHOUSE MARK 50

COUPLER ----- AAR TYPE BE-60-AHT

BRAKE ----- ABD 1012

BRAKE SLACK ADJUSTER ----- ELLCON NATIONAL-1340-4

HAND BRAKE ----- AJAX

BRAKE STEP (14600-14799, 14900-14999) ----- APEX

BRAKE STEP (14800-14899) ----- U.S. GYPSUM CO.

MARKED CAPACITY, LBS. ----- 154,000

LIGHT WEIGHT, LBS., AV. -14600-14799 ----- 55,300

MAX. WT. OF LADING, LBS., AV. -14600-14799 ----- 164,700

LIGHT WEIGHT, LBS., AV. -14800-14999 ----- 54,700

MAX. WT. OF LADING, LBS., AV. -14800-14999 ----- 165,300

CUBICAL CAPACITY, LEVEL, CU. FT. ----- 2603

CUBICAL CAPACITY, HEAPED ----- 2928

LENGTH INSIDE ----- 39'-10"

WIDTH INSIDE ----- 9'-9 1/2"

YEAR BUILT ----- 1966

BUILDER ----- BETHLEHEM STEEL CO.

DENVER & RIO GRANDE WESTERN R.R.
COVERED HOPPER CARS No's. 15000 to 15149

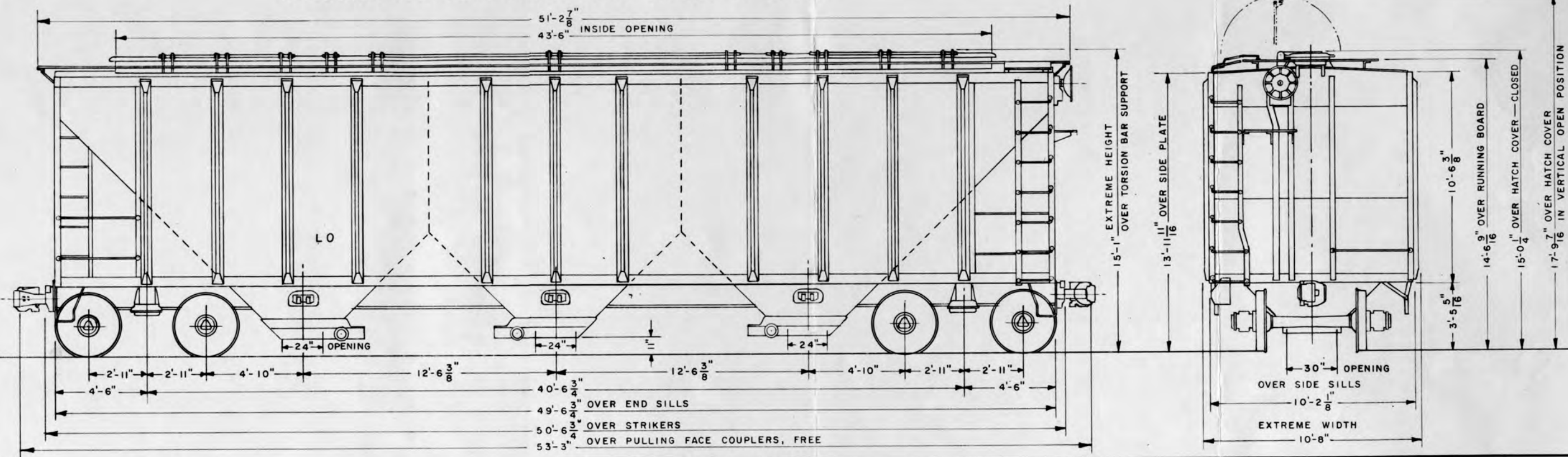

DESCRIPTION

GAUGE	4'-8 1/2"	SUPERSTRUCTURE	STEEL	MARKED CAPACITY, LBS.	199,000
JOURNALS (15000-15074)	6 1/2" X 12" TIMKEN ROLLER BEARINGS	UNDERFRAME	STEEL	LIGHT WEIGHT, LBS., AV.	63,500
JOURNALS (15075-15149)	6 1/2" X 12" HYATT ROLLER BEARINGS	LINING (15147, 15148, 15149)	POLYCLUTCH	MAXIMUM WEIGHT OF LADING, LBS., AV.	199,500
WHEELS	36" WROT STEEL 2-W	ROOF TROUGH HATCH	24" WIDE BY 43'-6" LONG INSIDE	CUBICAL CAPACITY, CU. FT.	4427
AXLE	D-6-D	DISCHARGE OPENINGS	THREE-24" X 30"	LENGTH INSIDE	49'-6 5/16"
TRUCK TYPE	ASF A-3 RIDE CONTROL, 2 1/2" SPRING TRAVEL	PNEUMATIC DISCHARGE OPENINGS (15147, 15148, 15149)	THREE-24" X 30"	WIDTH INSIDE	10'-1 1/2"
TRUCK SIDES	NARROW PEDESTAL TYPE	DRAFT GEAR	CARDWELL-WESTINGHOUSE-MARK 50	YEAR BUILT	1964
SIDE BEARINGS	DOUBLE ROLLER-STUCKI	COUPLER	AAR TYPE E	BUILDERS	PULLMAN STANDARD CAR MFG. CO.
BRAKE BEAMS	NO. 24-UNIT TYPE	BRAKE	AB 1210		
		BRAKE CYLINDER RELEASE VALVE	QRB		
		BRAKE SLACK ADJUSTER	ELLCON NATIONAL-TYPE 1340-4		
		HAND BRAKE	KLASING		
		RUNNING BOARDS AND BRAKE STEP	U.S. GYPSUM CO.-STEEL		

DENVER & RIO GRANDE WESTERN R.R.
COVERED HOPPER CARS No's. 15150 to 15399

AAR MECHANICAL DESIGNATION = LO

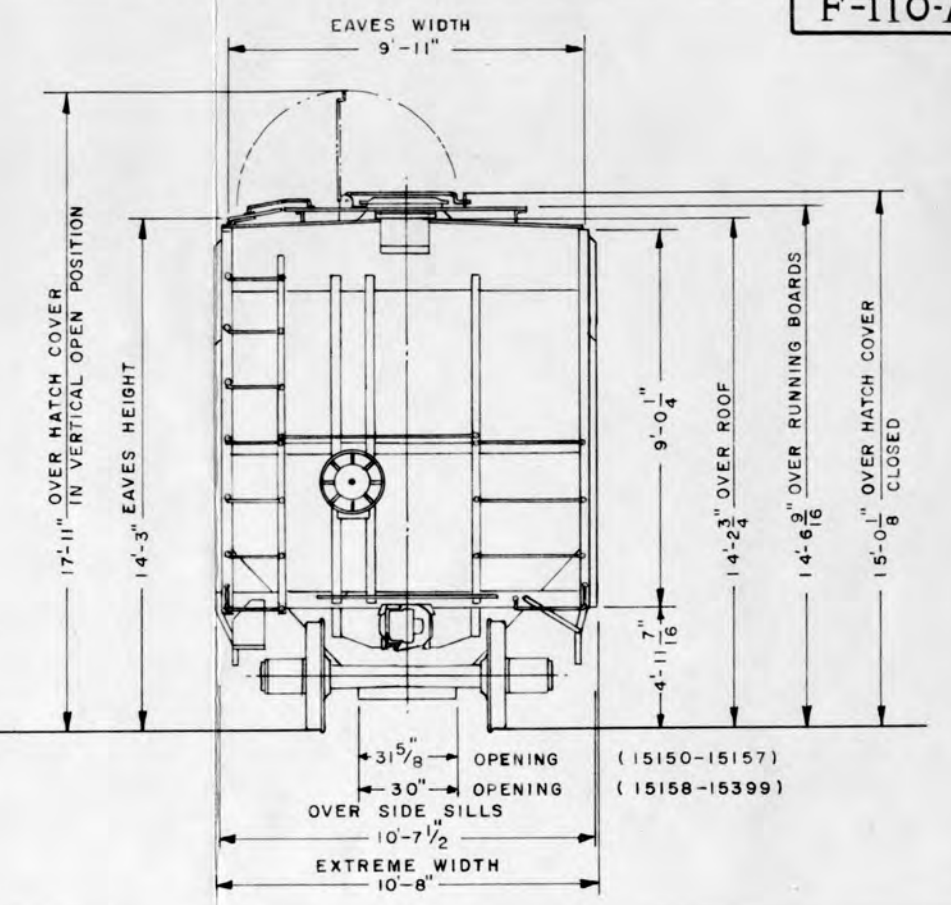
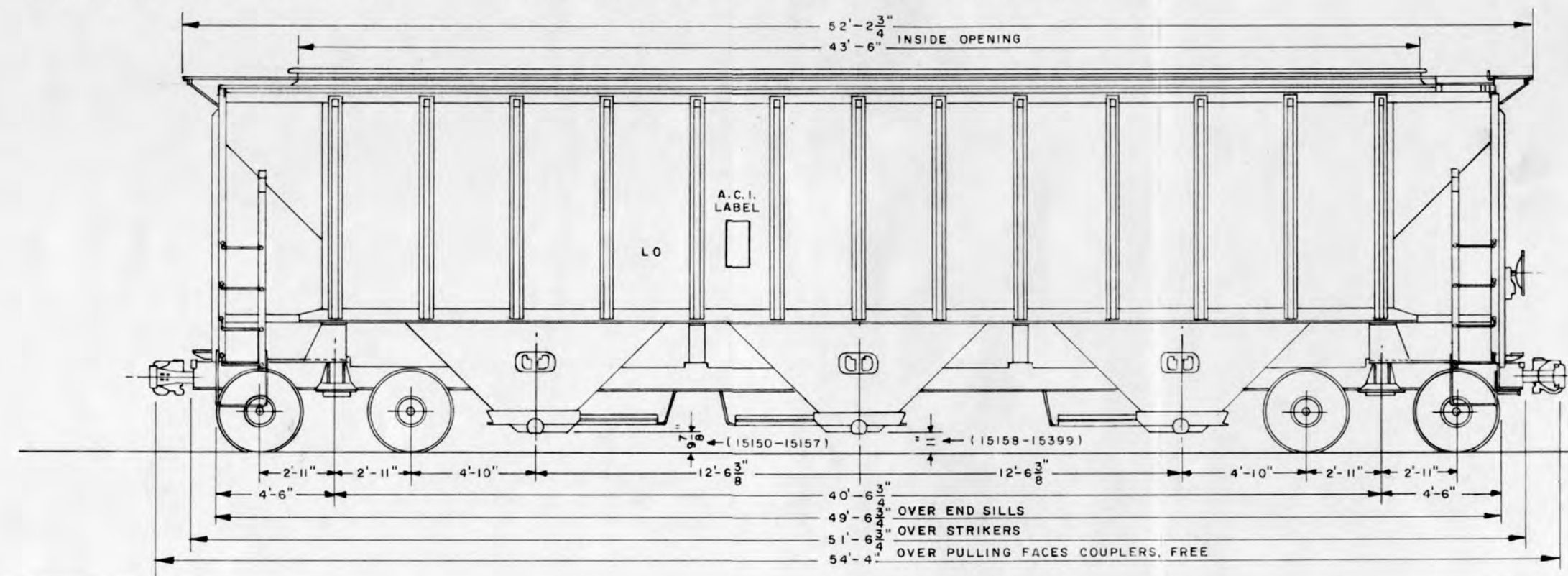

DESCRIPTION

GAUGE	4'-8 ¹ / ₂ "	SUPERSTRUCTURE	FABRICATED STEEL	MARKED CAPACITY, LBS.	200,000
JOURNALS (15150-15249)	6 ¹ / ₂ " X 12" HYATT ROLLER BEARINGS	UNDERFRAME	FABRICATED STEEL	LIGHT WEIGHT, LBS., AV. (15150-15249)	61,600
JOURNALS (15250-15399)	6 ¹ / ₂ " X 12" TIMKEN ROLLER BEARINGS	LINING (15150-15157)	POLYCLUTCH	LIGHT WEIGHT, LBS., AV. (15250-15399)	61,800
WHEELS	(J-36) 36" WROT STEEL 2-W	LINING (15250-15399)	EPOXY PRIMER AND URETHANE FINISH	MAXIMUM WEIGHT OF LADING, LBS., AV. (15150-15249)	201,400
AXLES	D-11-1967	ROOF TROUGH HATCH	24" WIDE BY 43'-6" LONG INSIDE	MAXIMUM WEIGHT OF LADING, LBS., AV. (15250-15399)	201,200
TRUCK TYPE	ASF A-3 RIDE CONTROL, 3 ¹¹ / ₁₆ " SPRING TRAVEL	HATCH COVER	4-PIECE FIBERGLASS	CUBICAL CAPACITY, CU. FT. - CENTER HOPPER	1279
TRUCK SIDES	NARROW PEDESTAL TYPE	DISCHARGE OPENINGS (15150-15157)	PNEUMATIC "GRAVAC"	CUBICAL CAPACITY, CU. FT. - END HOPPERS	1574
SIDE BEARINGS	STUCKI-DOUBLE ROLLER	DISCHARGE OPENINGS (15158-15399)	GRAVITY	CUBICAL CAPACITY, CU. FT. - TOTAL	4427
BRAKE BEAMS	WABOPAC	DRAFT GEAR	CARDWELL-WESTNGHOUSE - MARK 50	LENGTH INSIDE	49'-6 ⁵ / ₁₆ "
BRAKE SHOES	COBRA V-141 - COMPOSITION	COUPLER	BE-60-A-HT - AAR TYPE E	WIDTH INSIDE	10'-1 ¹ / ₂ "
		BRAKE	WABOPAC - 8 ¹ / ₂ " DIA. CYLINDER - ABD	YEAR BUILT (15150-15249)	1967
		HAND BRAKE	ELLCON NATIONAL - MODEL NO. 1600-2	YEAR BUILT (15250-15399)	1968
		RUNNING BOARDS AND END PLATFORMS	GALVANIZED STEEL - U.S. GYPSUM CO.	BUILDER	PULLMAN STANDARD CAR MFG. CO.

DENVER & RIO GRANDE WESTERN R.R.
 5 PSI PRESSURE DIFFERENTIAL COVERED HOPPER CARS
 No's. 15993 TO 15999

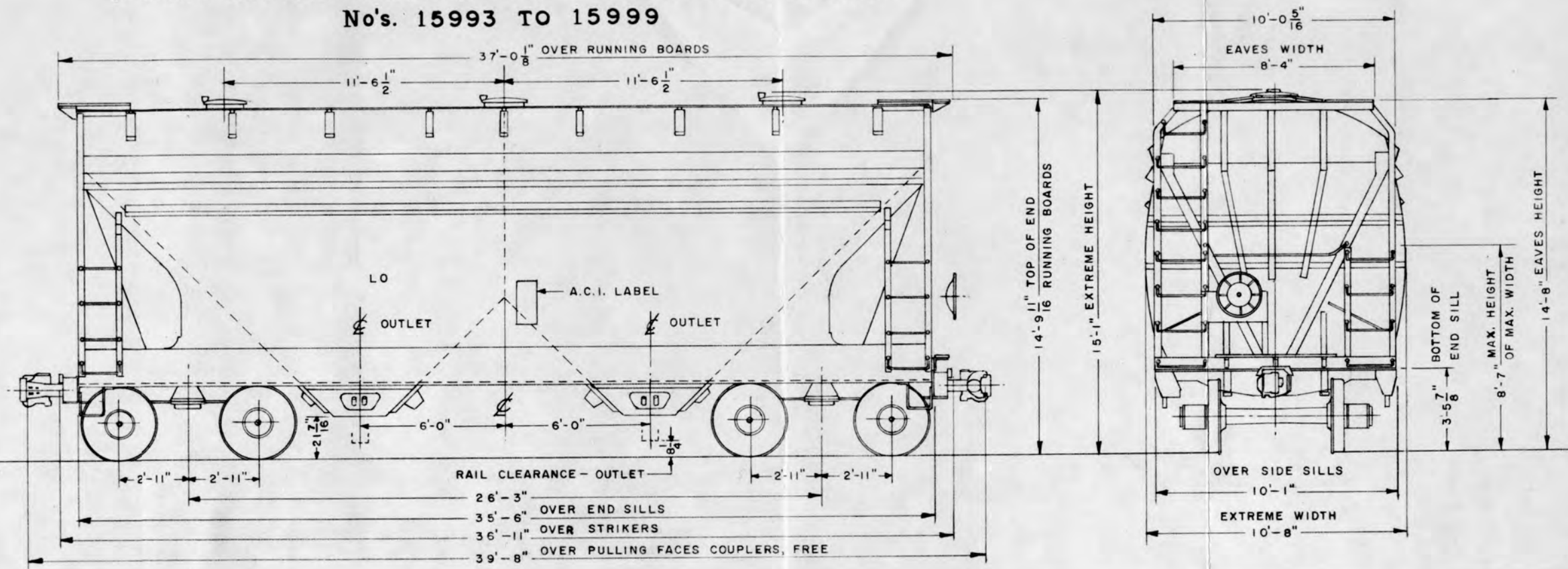

DESCRIPTION

GAUGE	4'-8 1/2"
JOURNALS	6 1/2" X 12" TIMKEN ROLLER BEARINGS
WHEELS	H-36, 36" WROT STEEL I-W
AXLES	D-II-67
TRUCK TYPE	ASF A-3 RIDE CONTROL, 2 1/2" SPRING TRAVEL
TRUCK SIDES	NARROW PEDESTAL TYPE
SIDE BEARINGS	STUCKI DOUBLE ROLLER
BRAKE BEAMS	WABCO PAC B3
BRAKE SHOES	COBRA V-141

SUPERSTRUCTURE	FABRICATED STEEL
UNDERFRAME	FABRICATED STEEL WITH Z-26 STUB CENTER SILL
ROOF HATCHES	THREE 20" DIA.
DISCHARGE OUTLETS	TWO 5" DIA. PNEUMATIC DISCHARGE TUBES CONTROLLED BY ONE 8" DIA., 5 PSI, FLUIDIZED BUTTERFLY VALVE FOR EACH COMPARTMENT.
COMBINATION PRESSURE RELIEF AND VACUUM RELIEF VALVE	5 PSIG MICROMAT MODEL R, ONE AT "B" END OF CAR.
RUPTURE DISC	CALMEC NO. 946 AT "A" END OF CAR
BLOW-DOWN VALVE	3" KEYSTONE AT "B" END OF CAR
PRESSURE GAUGES	(0 TO 15 PSI) ONE ON EACH SIDE OF "B" END OF CAR
DRAFT GEAR	MINER TYPE RF-361
COUPLER	NO. B-E60A-HT, AAR TYPE E
BRAKE	WABCO PAC B3, 8 1/2" DIA. CYLINDER-ABD
HAND BRAKE	ELLCON NATIONAL TYPE D-1600-2H
BRAKE STEP	APEX

MARKED CAPACITY, LBS.	200,000
LIGHT WEIGHT, LBS., AV. (ESTIMATED)	56,500
MAXIMUM WEIGHT OF LADING, LBS., AV. (ESTIMATED)	206,500
CUBICAL CAPACITY, CU. FT. — EACH COMPARTMENT	1485
CUBICAL CAPACITY, CU. FT. — TOTAL	2970
LENGTH INSIDE	34'-9"
WIDTH INSIDE	10'-7"
YEAR BUILT	1968
BUILDER	AMERICAN CAR AND FOUNDRY DIVISION

REISSUE
 JAN. 2, 1963.
 JULY 1, 1964.
 JAN. 2, 1965.

F-111

DENVER & RIO GRANDE WESTERN R.R.
 COVERED HOPPER CARS No's. 18000 to 18019

AAR MECHANICAL DESIGNATION = LO

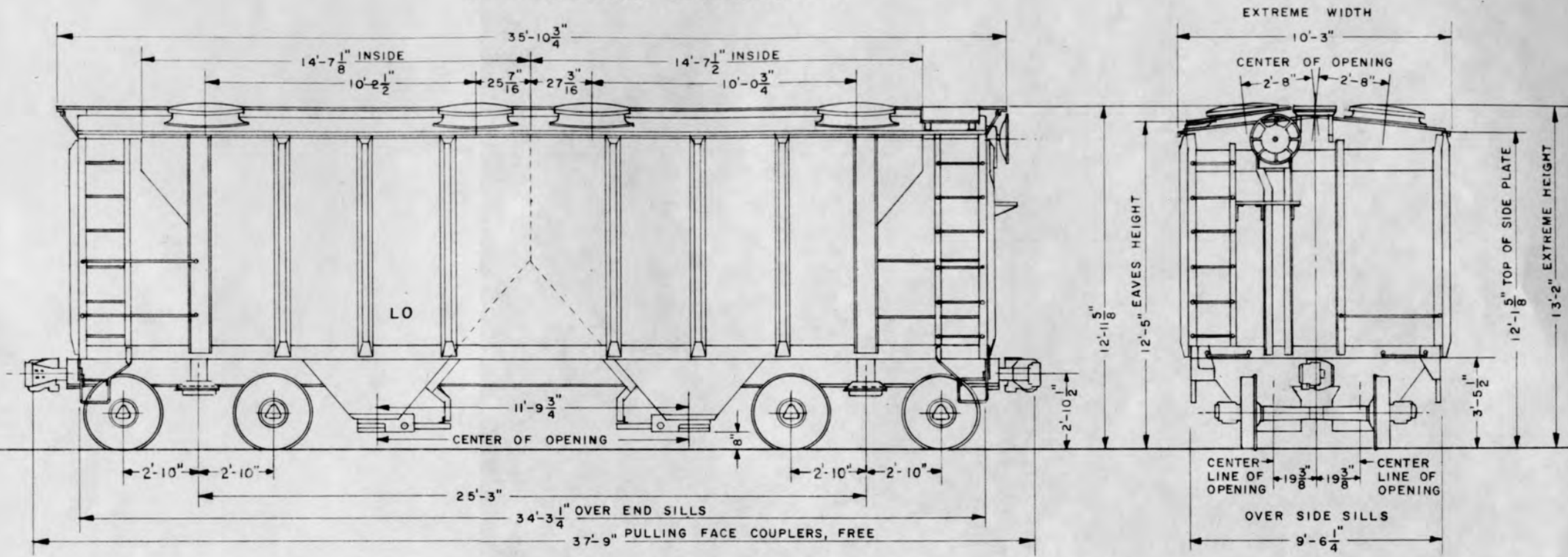

DESCRIPTION

GAUGE ----- 4'-8 1/2"	SUPERSTRUCTURE ----- STEEL	MARKED CAPACITY, LBS. ----- 154,000
JOURNALS ----- 6" X 11" TIMKEN ROLLER BEARINGS	UNDERFRAME ----- STEEL	LIGHT WEIGHT, LBS., AV. ----- 50,900
WHEELS ----- 33" ROLLED STEEL 1-W	ROOF HATCHES ----- EIGHT-30" DIA. OPENING	MAX. WEIGHT OF LADING, LBS., AV. ----- 169,100
TRUCK TYPE ___ ASF A-3 RIDE CONTROL, 2 1/2" SPRING TRAVEL	DISCHARGE OPENINGS ----- FOUR-13" X 24"	CUBICAL CAPACITY, CU. FT. ----- 2003
TRUCK SIDES ----- NARROW PEDESTAL TYPE	DRAFT GEAR ----- CARDWELL-WESTINGHOUSE NY-II-F	LENGTH INSIDE ----- 29'-3"
TRUCK BOLSTER ----- CAST STEEL	COUPLER ----- AAR TYPE E	WIDTH INSIDE ----- 9'-5 1/2"
SIDE BEARINGS ----- STUCKI	BRAKE ----- WESTINGHOUSE AB-1012	YEAR BUILT ----- 1960
BRAKE BEAMS ----- AMERICAN BRAKE SHOE CO.-NO. 18	HAND BRAKE ----- MINER	BUILDERS ----- GREENVILLE STEEL CAR CO.
	RUNNING BOARDS ----- U.S. GYPSUM CO.-STEEL	

DENVER & RIO GRANDE WESTERN R.R.
COVERED HOPPER No's. 18020 to 18099, 18110 to 18179

F-112

AAR MECHANICAL DESIGNATION = LO

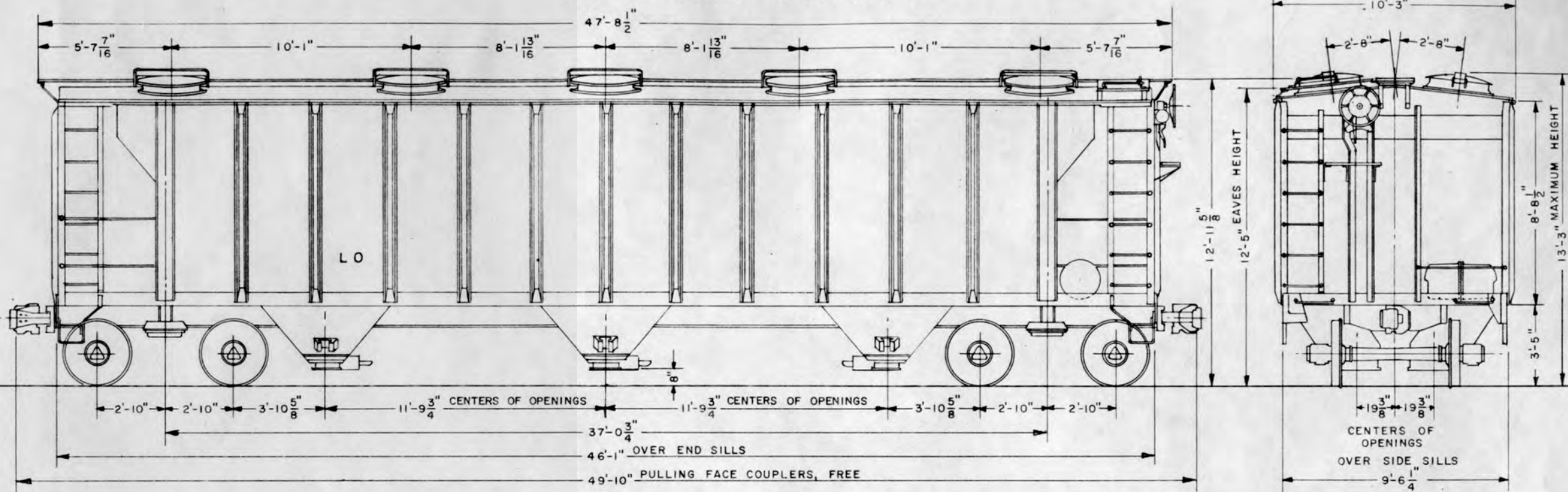

DESCRIPTION

GAUGE ----- 4'-8 1/2"	SUPERSTRUCTURE ----- STEEL	MARKED CAPACITY, LBS. ----- 154,000
JOURNALS ----- 6" X 11" TIMKEN ROLLER BEARINGS	UNDERFRAME ----- STEEL	LIGHT WEIGHT, LBS., AV. ----- 61,500
WHEELS ----- 33" WROT STEEL 1-W	ROOF HATCHES ----- TEN - 30" DIA. OPENING	MAX. WEIGHT OF LADING, LBS., AV. ----- 158,500
TRUCK ----- ASF A-3 RIDE CONTROL, 2 1/2" SPRING TRAVEL	DISCHARGE OPENINGS ----- SIX - 13" X 24"	CUBICAL CAPACITY, CU. FT ----- 2893
TRUCK SIDES ----- NARROW PEDESTAL TYPE	DRAFT GEAR ----- CARDWELL-WESTINGHOUSE MARK "50"	LENGTH INSIDE ----- 41'-0 3/4"
TRUCK BOLSTER ----- CAST STEEL	COUPLER ----- AAR TYPE E	WIDTH INSIDE ----- 9'-5 1/2"
SIDE BEARINGS ----- STUCKI ROLLER	BRAKE ----- WESTINGHOUSE AB 1012	YEAR BUILT ----- 1961
BRAKE BEAMS ----- UNIT TYPE NO. 18 - BUFFALO	HAND BRAKE ----- NON-SPIN TYPE - MINER	BUILDERS ----- GREENVILLE STEEL CAR CO.
	BRAKE SLACK ADJUSTER ----- WESTINGHOUSE MODEL D-II-D	
	RUNNING BOARDS ----- U.S. GYPSUM CO. - STEEL	

DENVER & RIO GRANDE WESTERN R.R.
 (AIR SLIDE) COVERED HOPPER CARS No's. 18100 to 18109, 18180 to 18184

AAR MECHANICAL DESIGNATION = LO

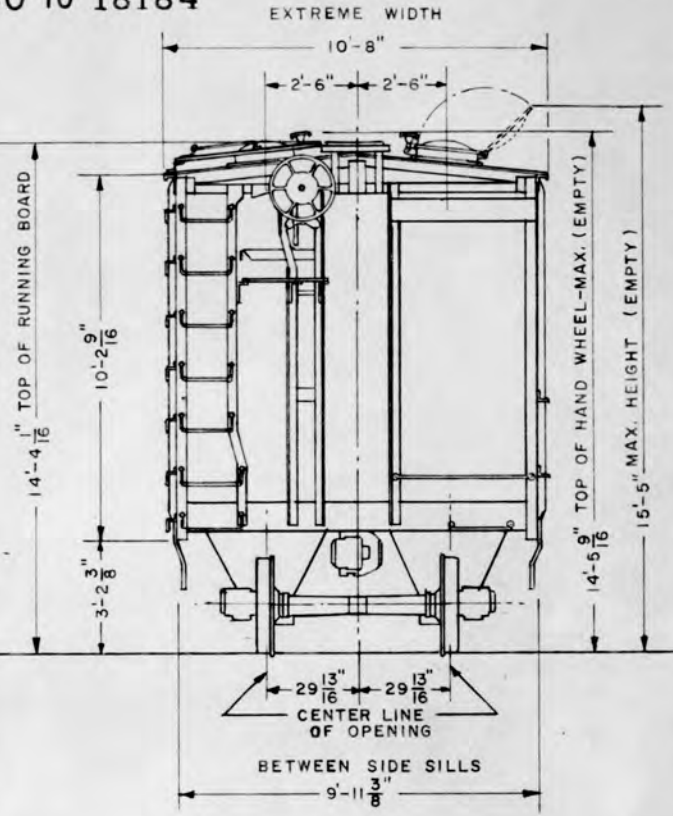
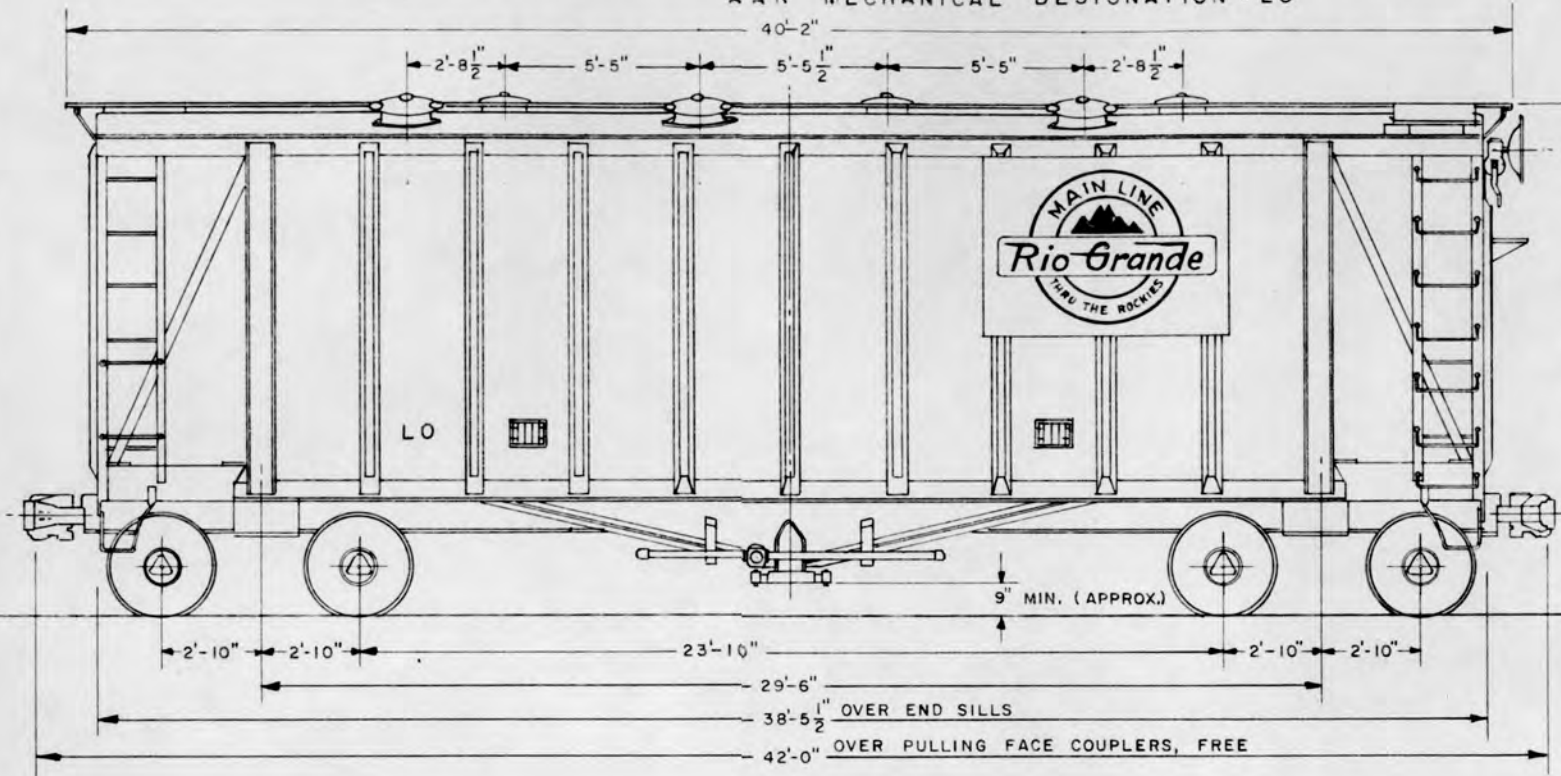

DESCRIPTION

GAUGE ----- 4'-8 1/2"	SUPERSTRUCTURE ----- STEEL	MARKED CAPACITY, LBS. ----- 154,000
JOURNALS ----- 6" X 11" TIMKEN ROLLER BEARINGS	UNDERFRAME ----- STEEL	LIGHT WT., LBS., AV. (18100-18109) ----- 57,400
WHEELS ----- 33" CAST STEEL 1-W	LINING ----- POLYCLUTCH	MAX. WT. OF LADING, LBS., AV. (18100-18109) ----- 162,600
TRUCK TYPE ----- BARBER S-2-A, 2 1/2" SPRING TRAVEL	ROOF HATCHES ----- SIX - 19 7/8" DIA. OPENING	LIGHT WT., LBS., AV. (18180-18184) ----- 56,600
TRUCK SIDES-NARROW PEDESTAL TYPE, SYMINGTON-WAYNE	DISCHARGE OPENINGS ----- TWO- 9" X 12"	MAX. WT. OF LADING, LBS., AV. (18180-18184) ----- 163,400
TRUCK BOLSTER ----- CAST STEEL	DRAFT GEAR ----- FRICTION TYPE	CUBICAL CAPACITY, CU. FT. ----- 2,600
SIDE BEARINGS ----- STUCKI ROLLER	COUPLER ----- AAR TYPE E	LENGTH INSIDE ----- 29'-6"
BRAKE BEAMS ----- UNIT TYPE NO. 18	BRAKE ----- WESTINGHOUSE AB-1012	WIDTH INSIDE ----- 9'-11"
	HAND BRAKE ----- VERTICAL WHEEL - NON-SPIN TYPE	YEAR BUILT (18100-18109) ----- 1960
	RUNNING BOARDS ----- APEX - STEEL	YEAR BUILT (18180-18184) ----- 1962
		BUILDERS ----- GENERAL AMERICAN TRANSPORTATION CORP.

REISSUE
 JUNE 13, 1958
 SEPT. 1, 1959,
 JAN. 2, 1962.
 JAN. 2, 1963.

F-115

DENVER & RIO GRANDE WESTERN R. R.
 COVERED HOPPER CARS No's. 18225 to 18324

AAR MECHANICAL DESIGNATION = L O

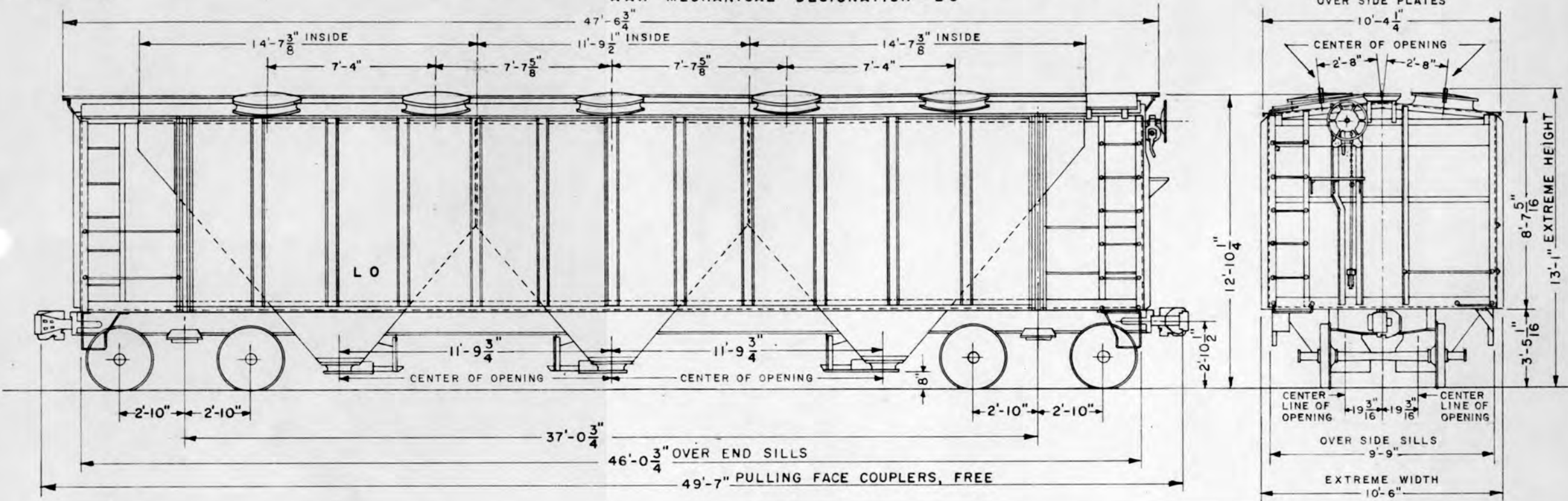

DESCRIPTION

GAUGE	4'-8 1/2"	ROOF	STEEL	MARKED CAPACITY, LBS.	154,000
JOURNALS	6" X 11"	ENDS	STEEL	LIGHT WEIGHT, LBS., AV.	61,800
WHEELS	33" WROT STEEL I-W	SIDES	STEEL	MAX. WEIGHT OF LADING, LBS., AV.	158,200
TRUCK TYPE	BARBER STABILIZED S-2-A 2 1/2" SPRING TRAVEL	UNDERFRAME	STEEL	CUBICAL CAPACITY, CU. FT.-CENTER COMPARTMENTS	918
TRUCK SIDES	CAST STEEL-INTEGRAL BOXES	LINING (18276, 18304)	ADM-410	CUBICAL CAPACITY, CU. FT.-END COMPARTMENTS	2009
TRUCK BOLSTER	CAST STEEL	ROOF HATCHES	TEN-30" DIA.	CUBICAL CAPACITY, CU. FT.-AT EAVES (TOTAL)	2927
SIDE BEARINGS	STUCKI	DISCHARGE OPENINGS	SIX-13" X 24"	LENGTH INSIDE	41'-0 3/4"
BRAKE BEAMS	ASF-CAST STEEL-NO. 18-UNIT TYPE	AUX. PNEU. DISCH. OPENINGS {18276, 18292, 18294, 18301, 18304}	6	WIDTH INSIDE	9'-9"
		DRAFT GEAR	CARDWELL-WESTINGHOUSE NY-11-F		
		COUPLER	AAR TYPE E		
		BRAKE	AB		
		HAND BRAKE	MINER		
				YEAR BUILT-18225-18274	1958
		BRAKE GEAR REGULATOR (18225-18274)	UNIVERSAL	YEAR BUILT-18275-18324	1957
		RUNNING BOARDS (18225-18274)	U.S. GYPSUM CO-STEEL	BUILDERS	AMERICAN CAR & FOUNDRY CO.
		RUNNING BOARDS (18275-18324)	APEX-STEEL		

DENVER & RIO GRANDE WESTERN R. R.
 COVERED HOPPER CARS No's. 18325 to 18349,
 18475 to 18499

AAR MECHANICAL DESIGNATION = LO

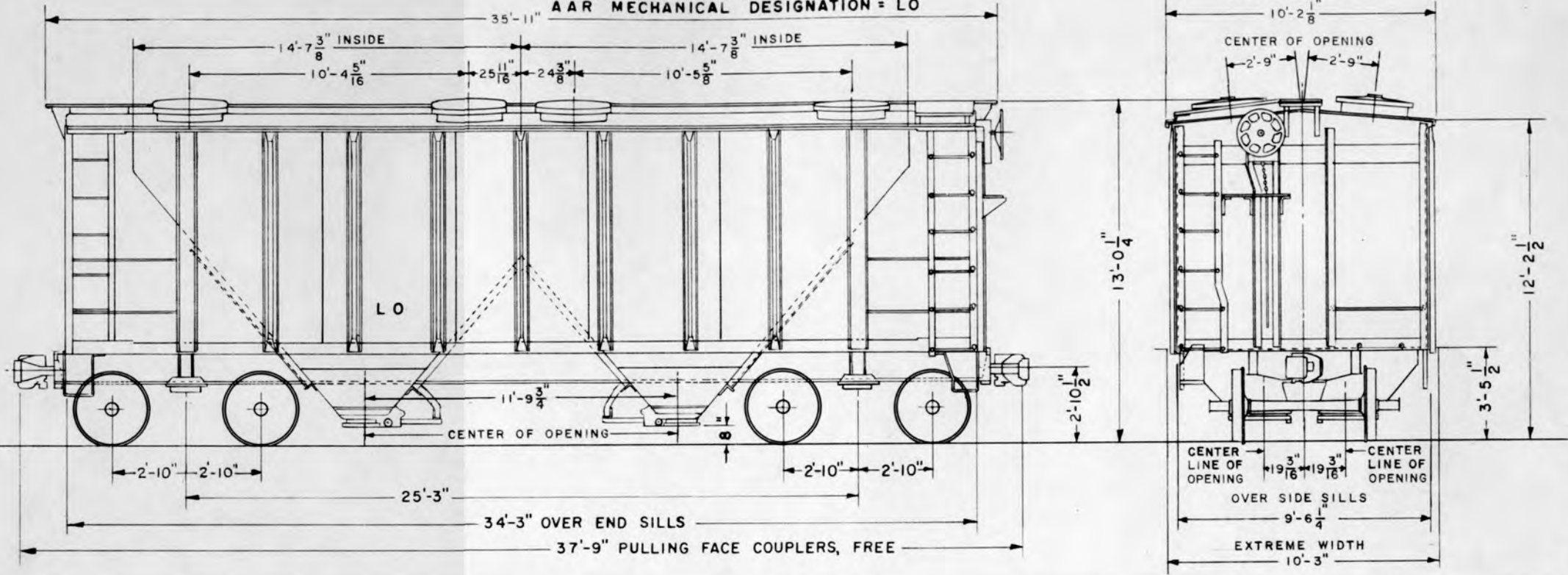

DESCRIPTION

GAUGE ----- 4'-8 1/2"
 JOURNALS ----- 6" X 11"
 WHEELS ----- 33" ROLLED STEEL-1W
 TRUCK TYPE --- ASF A-3 RIDE CONTROL, 2 1/2" SPRING TRAVEL
 TRUCK SIDES ----- CAST STEEL-INTEGRAL BOXES
 TRUCK BOLSTER ----- CAST STEEL

 SIDE BEARINGS ----- PSCM CO.-ROLLER TYPE

 BRAKE BEAMS(18325-18349) --- CRECO NO. 18-UNIT TYPE
 BRAKE BEAMS(18475-18499)-APEX BOXWELD NO.18-UNIT TYPE

ROOF 18325-18349 --- HIGH TENSILE, LOW ALLOY STEEL
 ROOF 18475-18499 ----- STEEL
 ENDS ----- STEEL
 SIDES ----- STEEL
 UNDERFRAME ----- STEEL
 ROOF HATCHES ----- EIGHT-30" DIA. OPENING
 DISCHARGE OPENINGS ----- FOUR-13" X 24"

 DRAFT GEAR ----- CARDWELL-WESTINGHOUSE NY-II-F
 COUPLER ----- AAR TYPE E

 BRAKE ----- WESTINGHOUSE AB-1012
 HAND BRAKE ----- UNIVERSAL
 BRAKE GEAR REGULATOR ----- PSCM CO.

 RUNNING BOARDS ----- APEX

MARKED CAPACITY, LBS. ----- 154,000
 LIGHT WEIGHT, LBS., AV. ----- 50,800
 MAX. WEIGHT OF LADING, LBS., AV. ----- 169,200

 CUBICAL CAPACITY, CU. FT. ----- 2003

 LENGTH INSIDE ----- 29'-3"
 WIDTH INSIDE ----- 9'-5 1/2"

 YEAR BUILT ----- 1956
 BUILDERS ----- PULLMAN STD. CAR MFG. CO.

DENVER & RIO GRANDE WESTERN R.R.
 COVERED HOPPER CARS No's. 18350 to 18399
 AAR MECHANICAL DESIGNATION = L O

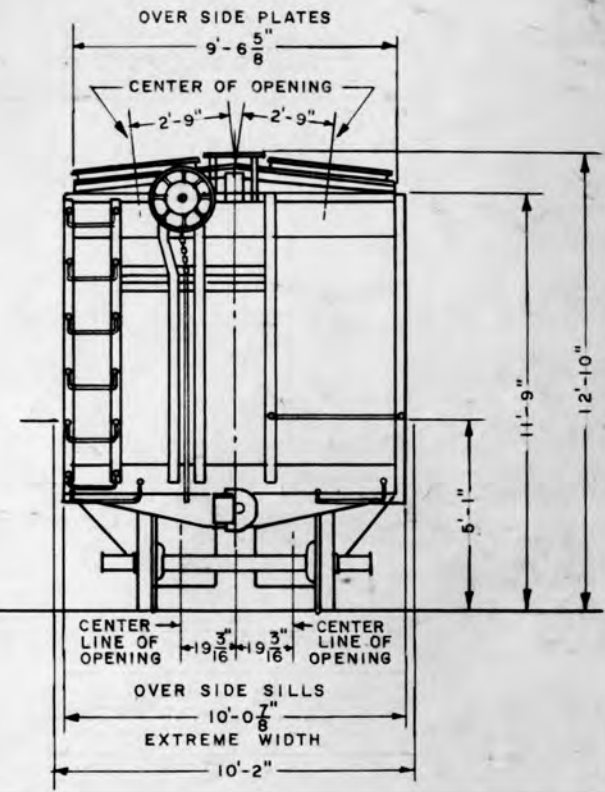
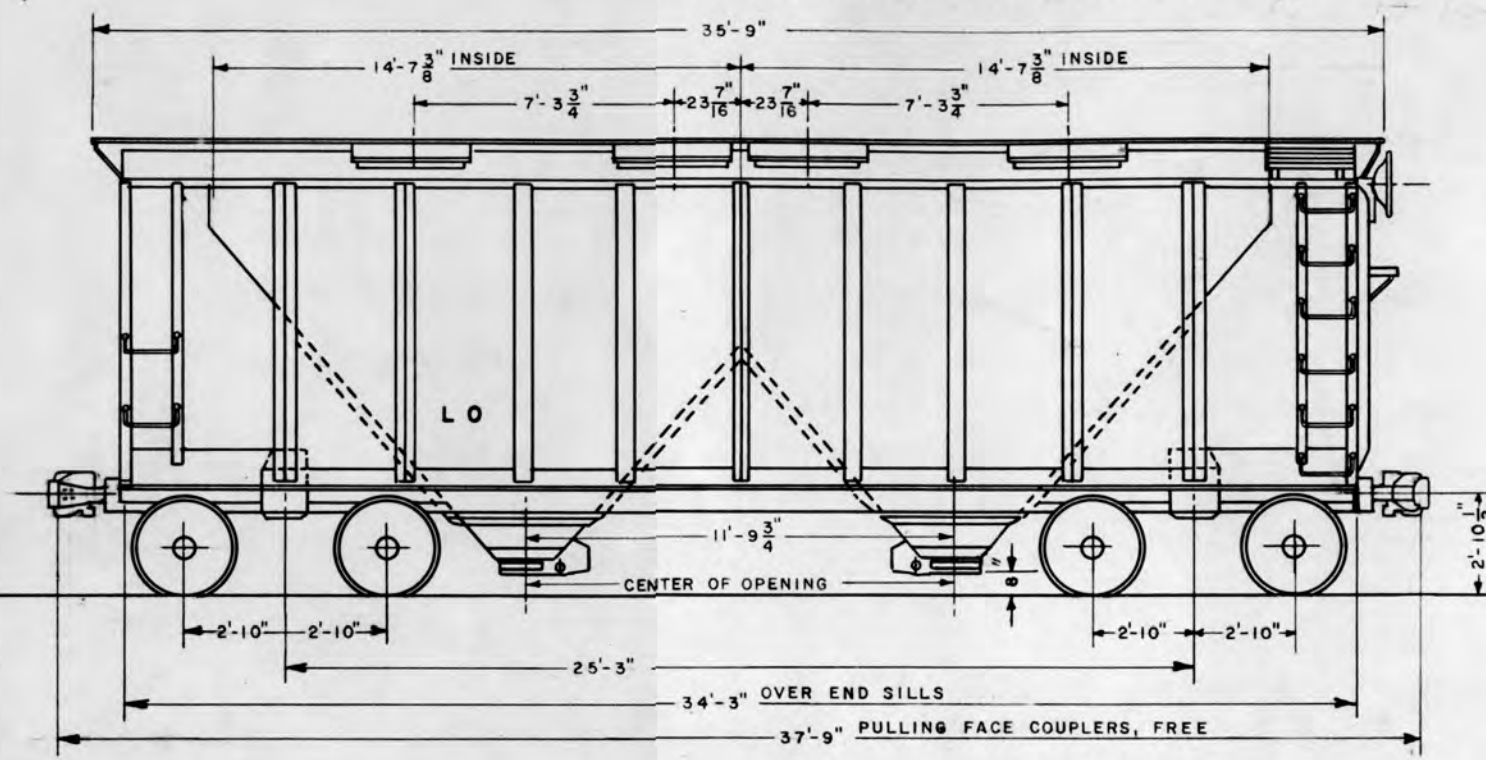

DESCRIPTION

GAUGE	4'-8 1/2"	ROOF (18350-18374)	MURPHY IMPROVED-SOLID STEEL	MARKED CAPACITY, LBS.	154,000
JOURNALS	6" X 11"	ROOF (18375-18399)	PULLMAN STANDARD	LIGHT WEIGHT, LBS., AV.	51,500
WHEELS	33" WROT STEEL I-W	SUPERSTRUCTURE	STEEL	MAX. WEIGHT OF LADING, LBS., AV.	168,500
TRUCK TYPE	ASF A-3 RIDE CONTROL, 2 1/2" SPRING TRAVEL	UNDERFRAME	STEEL	CUBICAL CAPACITY, CU. FT. (AT EAVES)	1892
TRUCK SIDES	CAST STEEL-INTEGRAL BOXES	ROOF HATCHES	EIGHT 3'-0" X 3'-0"	CUBICAL CAPACITY, CU. FT. (AT ROOF CARLINE)	1958
TRUCK BOLSTER	CAST STEEL	DISCHARGE OPENINGS	FOUR 13" X 24"	LENGTH INSIDE	29'-3"
SIDE BEARINGS (18350-18374)	STUCK I	DRAFT GEAR (18350-18374)	MINER A-22-XB	WIDTH INSIDE	9'-5 1/2"
SIDE BEARINGS (18375-18399)	MONOCAST	DRAFT GEAR (18375-18399)	CARDWELL-WEST, NY-II-F		
BRAKE BEAMS (18350-18374)	AAR NO. 3-BUILT-UP	COUPLER	AAR TYPE E		
BRAKE BEAMS-(18375-18399)	ASF-CAST STEEL-NO. 18.-UNIT TYPE	BRAKE	AB	YEAR BUILT (18350-18374)	1946
		HAND BRAKE (18350-18374)	AJAX	BUILDERS	GENERAL AMERICAN TRANSPORTATION CORP.
		HAND BRAKE (18375-18399)	UNIVERSAL	YEAR BUILT (18375-18399)	1949
		BRAKE GEAR REGULATOR (18350-18374 ONLY)	ROYAL-TYPE F	BUILDERS	PULLMAN STANDARD CAR MFG. CO.
		RUNNING BOARDS	STEEL-APEX		

DENVER & RIO GRANDE WESTERN R.R.
 COVERED HOPPER CARS No's. 18400 to 18449

AAR MECHANICAL DESIGNATION = L O

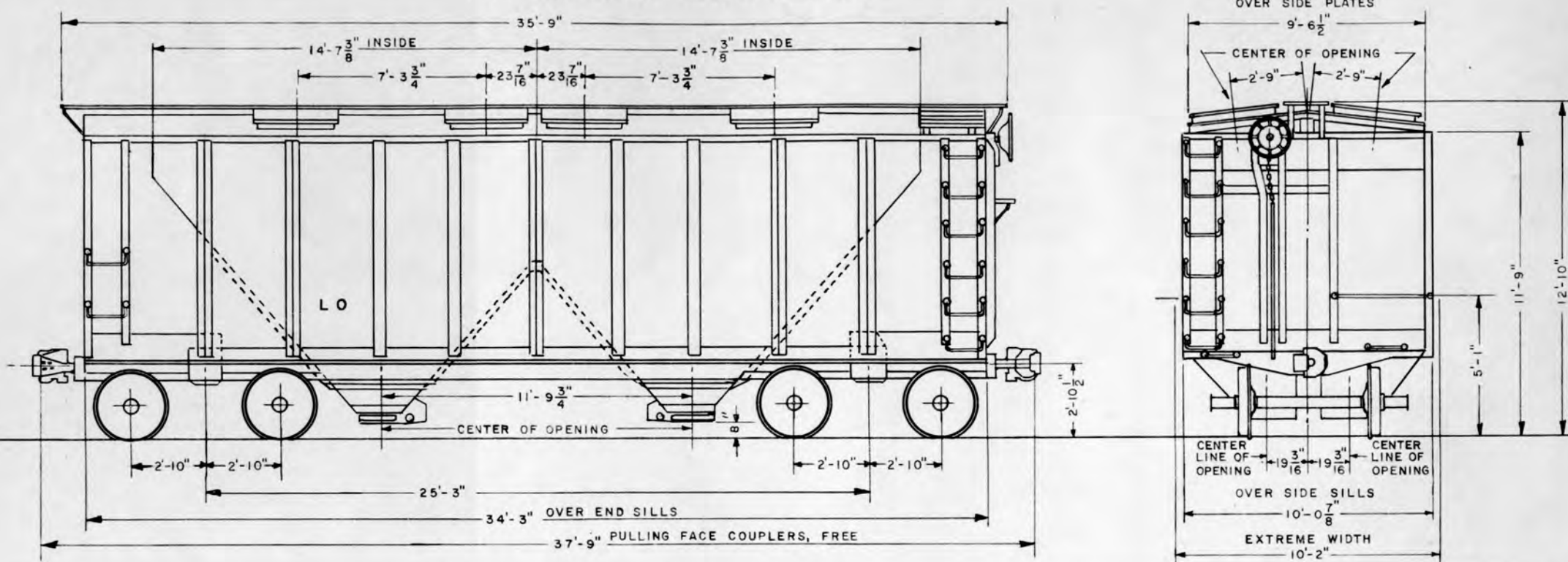

DESCRIPTION

GAUGE ----- 4'-8 1/2"	ROOF (18400-18424) _MURPHY IMPROVED-SOLID STEEL	MARKED CAPACITY, LBS. ----- 154,000
JOURNALS ----- 6" X 11"	ROOF (18425-18449) ----- PULLMAN STANDARD	LT. WT., LBS., AV. (18400-18424) ----- 50,100
WHEELS ----- 33" WROT STEEL 1-W	SUPERSTRUCTURE ----- STEEL	MAX. WT. OF LADING, LBS., AV. (18400-18424) ----- 169,900
TRUCK TYPE-ASF A-3 RIDE CONTROL, 2 1/2" SPRING TRAVEL	UNDERFRAME ----- STEEL	LT. WT., LBS., AV. (18425-18449) ----- 50,500
TRUCK SIDES ----- CAST STEEL-INTEGRAL BOXES	ROOF HATCHES ----- EIGHT 3'-0" X 3'-0"	MAX. WT. OF LADING, LBS., AV. (18425-18449) ----- 169,500
TRUCK BOLSTER ----- CAST STEEL	DISCHARGE OPENINGS ----- FOUR 13" X 24"	CUBICAL CAPACITY, CU. FT. (AT EAVES) ----- 1892
SIDE BEARINGS ----- STUCKI	DRAFT GEAR (18400-18424) ----- CARDWELL-WEST, NY-II-F	CUBICAL CAPACITY, CU. FT. (AT ROOF CARLINE) ----- 1958
BRAKE BEAMS (18400-18424) _NO. 18 UNIT TYPE -BUILT-UP	DRAFT GEAR (18425-18449) ----- MINER A-22-XL	LENGTH INSIDE ----- 29'-3"
BRAKE BEAMS (18425-18449) ASF-CAST STEEL-NO.18-UNIT TYPE	COUPLER ----- AAR TYPE E	WIDTH INSIDE ----- 9'-5 1/2"
	BRAKE ----- AB	
	HAND BRAKE (18400-18424) ----- MINER	
	HAND BRAKE (18425-18449) ----- UNIVERSAL	
	BRAKE GEAR REGULATOR ----- PNEUMATIC-AJAX	YEAR BUILT (18400-18424) ----- 1951
	RUNNING BOARDS (18400-18424) ----- STEEL, BLAW-KNOX	BUILDERS ----- AMERICAN CAR & FOUNDRY CO.
	RUNNING BOARDS (18425-18449) ----- STEEL - GYPSUM	YEAR BUILT (18425-18449) ----- 1952
		BUILDERS ----- PULLMAN STANDARD CAR MFG. CO.

DENVER & RIO GRANDE WESTERN R.R.
 COVERED HOPPER CARS No's. 18450 to 18474
 AAR MECHANICAL DESIGNATION = LO

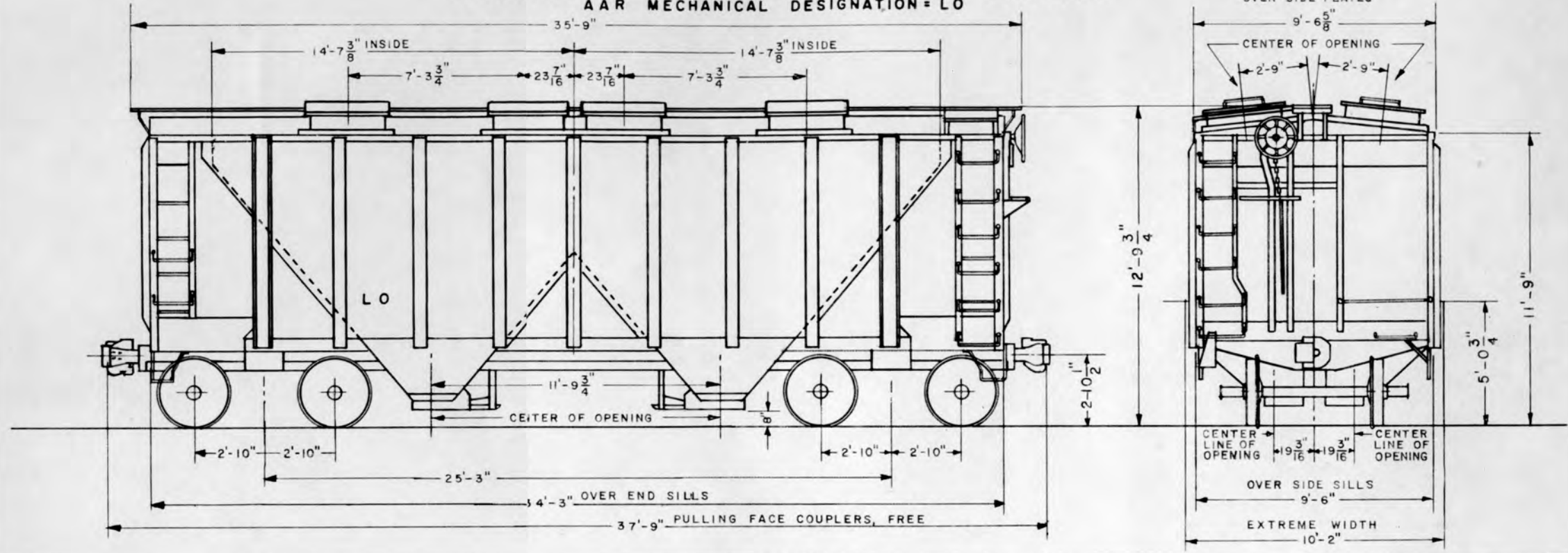

DESCRIPTION

GAUGE	4'-8 1/2"	ROOF	STEEL	MARKED CAPACITY, LBS.	154,000
JOURNALS	6" X 11"	ENDS	STEEL	LIGHT WEIGHT, LBS.	51,700
WHEELS	WROT STEEL I-W	SIDES	STEEL	MAX. WEIGHT OF LADING, LBS.	168,300
TRUCK TYPE	ASF A-3 RIDE CONTROL, 2 1/2" SPRING TRAVEL	UNDERFRAME	STEEL	CUBICAL CAPACITY, CU. FT. - AT EAVES	1,892
TRUCK SIDES	CAST STEEL - INTEGRAL BOXES	ROOF HATCHES	EIGHT - 3'-0" X 3'-0"	CUBICAL CAPACITY, CU. FT. - ROOF CARLINE	1,958
TRUCK BOLSTER	CAST STEEL	DISCHARGE OPENINGS	13" X 24"	LENGTH INSIDE	29'-3"
SIDE BEARINGS	SINGLE ROLLER - STUCKI	DRAFT GEAR	PEERLESS TYPE H-1-B2	WIDTH INSIDE	9'-5 1/2"
BRAKE BEAMS	ASF CAST STEEL NO. 18-UNIT TYPE	COUPLER	AAR TYPE E		
		BRAKE	AB	YEAR BUILT	1953
		HAND BRAKE	UNIVERSAL	BUILDERS	PULLMAN STD. CAR MFG. CO.
		RUNNING BOARDS	STEEL-APEX		

DENVER & RIO GRANDE WESTERN R.R.
TRUCK FRAME TRANSPORT FLAT CARS No's. 20007 to 20010

AAR MECHANICAL DESIGNATION = FMS

20007	FORMERLY	22247
20008	"	22299
20009	"	22307
20010	"	22310

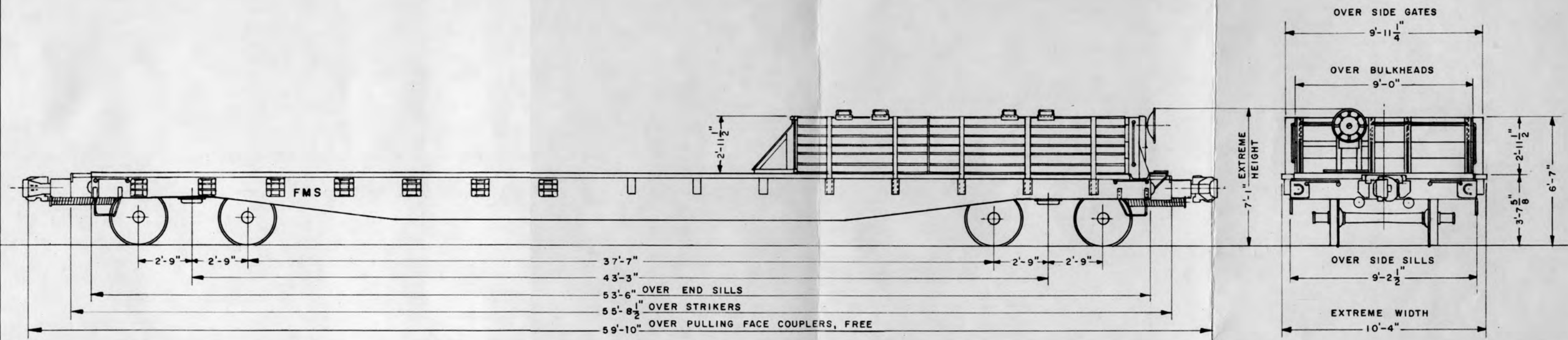

DESCRIPTION

GAUGE	4'-8 1/2"	DECK	WOOD	MARKED CAPACITY, LBS.	110,000
JOURNALS	5 1/2" X 10"	UNDERFRAME	STEEL	LIGHT WEIGHT, LBS., AV.	63,400
WHEELS	33" STEEL 1-W	DRAFT GEAR	A. O. SMITH - 12" TRAVEL - HYDRA-BUFF	MAX. WEIGHT OF LADING, LBS., AV.	113,600
TRUCK TYPE	ASF A-3 RIDE CONTROL-SPRING PLANKLESS	COUPLER	AAR TYPE E	LENGTH OVER DECK	53'-6"
SPRING TRAVEL	3 1/8"	BRAKE	AB	WIDTH OVER DECK	10'-3 3/4"
TRUCK SIDES	CAST STEEL- INTEGRAL BOXES	HAND BRAKE	UNIVERSAL - VERTICAL WHEEL	YEAR BUILT AS FLAT CAR (20007)	1951
TRUCK BOLSTER	CAST STEEL	BRAKE SLACK ADJUSTER	PNEUMATIC-AJAX	YEAR BUILT AS FLAT CARS (20008, 20009, 20010)	1944
SIDE BEARINGS	STUCKI			BUILDER (20007)	D&RGW
				BUILDER (20008, 20009, 20010)	MT. VERNON CAR MFG. CO.
				REBUILT AS TRUCK FRAME TRANSPORT FLAT CARS BY D&RGW	1962

DENVER & RIO GRANDE WESTERN R.R.
COMMERCIAL FRAME TRANSPORT FLAT CARS No's. 20011 to 20014
AAR MECHANICAL DESIGNATION = FMS

20011 FORMERLY 20002
20012 " 20000
20013 " 20004
20014 " 22267

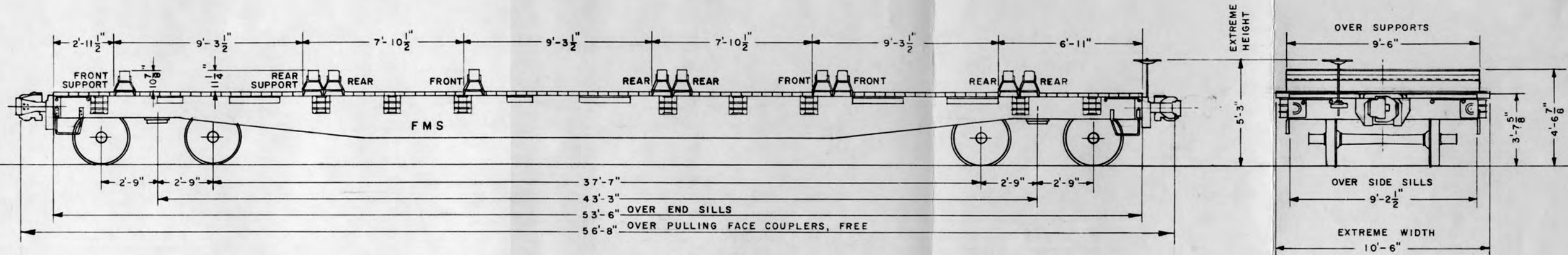

DESCRIPTION

GAUGE ----- 4'-8 1/2"
JOURNALS ----- 5 1/2" x 10
WHEELS ----- 33" STEEL 1-W
TRUCK TYPE ----- TRUCK ASSOCIATION- SPRING PLANK
SPRING TRAVEL ----- 2 1/2"
TRUCK SIDES ----- CAST STEEL- INTEGRAL BOXES
TRUCK BOLSTER ----- CAST STEEL
SIDE BEARINGS ----- STUCKI

DECK ----- WOOD
SUPPORT BEAMS ----- 10
UNDERFRAME ----- STEEL
DRAFT GEAR ----- CARDWELL- WESTINGHOUSE NY-II-F
COUPLER ----- AAR TYPE E
BRAKE ----- AB
HAND BRAKE ----- UNIVERSAL DROP SHAFT
BRAKE SLACK ADJUSTER ----- ROYAL TYPE F

MARKED CAPACITY, LBS. ----- 110,000
LIGHT WEIGHT, LBS., AV. ----- 52,200
MAX. WEIGHT OF LADING, LBS., AV. ----- 124,800

LENGTH OVER DECK ----- 53'-6"
WIDTH OVER DECK ----- 10'-6"

YEAR BUILT AS FLAT CARS ----- 1944
BUILDER ----- MT. VERNON CAR MFG. CO.
REBUILT AS COMMERCIAL FRAME FLAT CARS BY D&RGW ----- 1962

DENVER & RIO GRANDE WESTERN R.R.
COMMERCIAL FRAME TRANSPORT FLAT CARS No's. 20011 to 20014
 AAR MECHANICAL DESIGNATION = FMS

20011	FORMERLY	20002
20012	"	20000
20013	"	20004
20014	"	22267

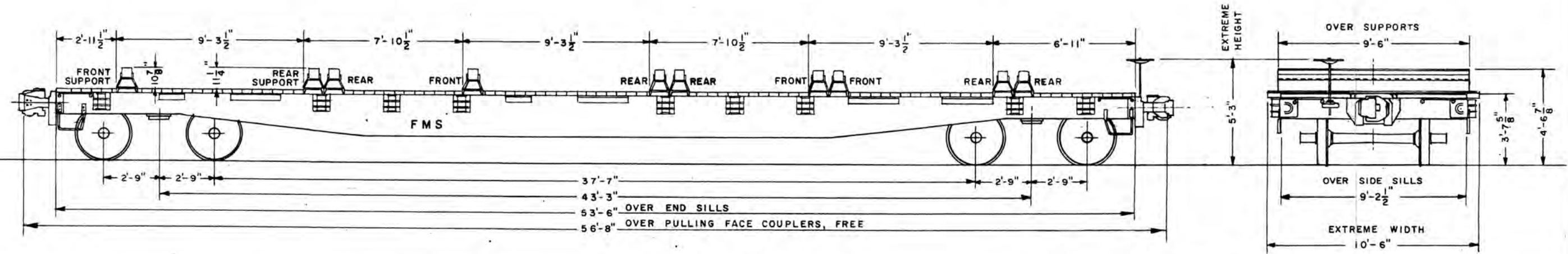

DESCRIPTION

GAUGE	4'-8 1/2"
JOURNALS	5 1/2" X 10
WHEELS	33" STEEL 1-W
TRUCK TYPE	TRUCK ASSOCIATION- SPRING PLANK
SPRING TRAVEL	2 1/2"
TRUCK SIDES	CAST STEEL- INTEGRAL BOXES
TRUCK BOLSTER	CAST STEEL
SIDE BEARINGS	STUCKI

DECK	WOOD
SUPPORT BEAMS	10
UNDERFRAME	STEEL
DRAFT GEAR	CARDWELL- WESTINGHOUSE NY-11-F
COUPLER	AAR TYPE E
BRAKE	AB
HAND BRAKE	UNIVERSAL DROP SHAFT
BRAKE SLACK ADJUSTER	ROYAL TYPE F

MARKED CAPACITY, LBS.	110,000
LIGHT WEIGHT, LBS., AV.	52,200
MAX. WEIGHT OF LADING, LBS., AV.	124,800
LENGTH OVER DECK	53'-6"
WIDTH OVER DECK	10'-6"

YEAR BUILT AS FLAT CARS ----- 1944
 BUILDER ----- MT. VERNON CAR MFG. CO.
 REBUILT AS COMMERCIAL FRAME FLAT CARS BY D&RGW ----- 1962

REISSUE
 JAN. 2, 1952
 SEPT. 1, 1959.
 JAN. 2, 1963.

DENVER & RIO GRANDE WESTERN R.R.
 FLAT CARS No's. 22003 to 22238

F-129

AAR MECHANICAL DESIGNATION = FM

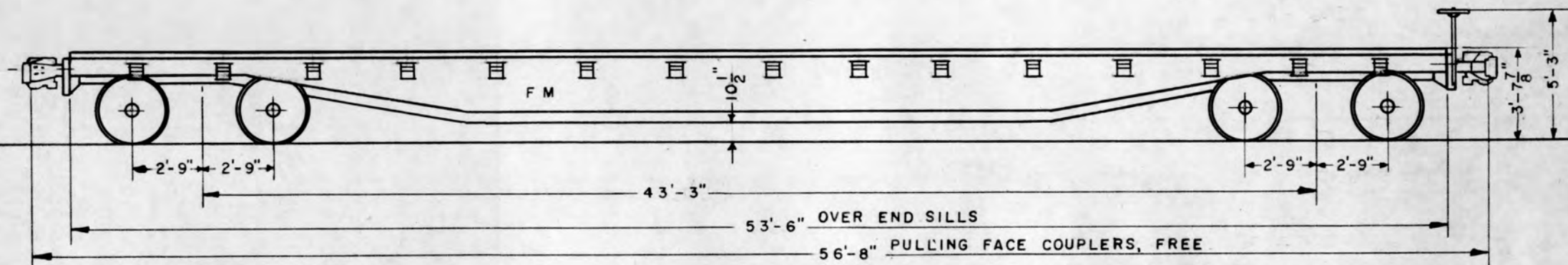
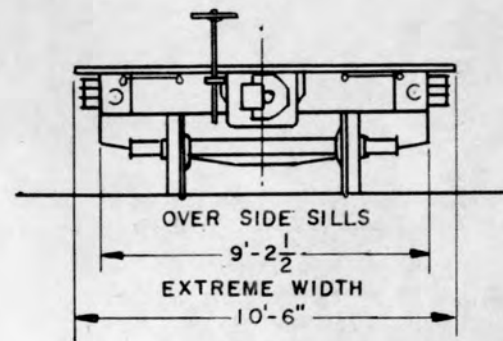

DESCRIPTION

GAUGE ----- 4'-8 1/2"	UNDERFRAME ----- STEEL	MARKED CAPACITY, LBS. ----- 110,000
JOURNALS ----- 5 1/2" X 10"		LT. WT., LBS., AV. (22003-22198) ----- 49,200
WHEELS ----- 33" CAST IRON		LT. WT., LBS., AV. (22216-22238) ----- 51,100
22003 - 22198		MAX. WT. OF LADING, LBS., AV. (22003-22198) ----- 127,800
TRUCK TYPE ----- TRUCK ASSOCIATION - SPRING PLANK		MAX. WT. OF LADING, LBS., AV. (22216-22238) ----- 125,900
22216 - 22238	DRAFT GEAR ----- CARDWELL-WESTINGHOUSE NY-II-F	LENGTH OVER DECKING ----- 53'-6"
TRUCK TYPE ----- <i>CAST</i> { ASF A-3 RIDE CONTROL, SPRING PLANKLESS, 3 1/16" SPRING TRAVEL	COUPLER ----- AAR TYPE E	WIDTH OVER DECKING ----- 10'-6"
	<i>SIDE BEARINGS</i>	BRAKE ----- AB
	HAND BRAKE ----- UNIVERSAL DROP SHAFT	
TRUCK SIDES ----- CAST STEEL - INTEGRAL BOXES	BRAKE SLACK ADJUSTER (22003-22198) ----- ROYAL TYPE F	YEAR BUILT (22003-22198) ----- 1944
TRUCK BOLSTER ----- CAST STEEL	BRAKE SLACK ADJUSTER (22216-22238) ----- PNEU, -AJAX	BUILDERS (22003-222198) ----- MT. VERNON CAR MFG. CO.
SIDE BEARINGS ----- STUCKI		YEAR BUILT (22216-22238) ----- 1951
		BUILDERS (22216-22238) ----- D & R G W

DENVER & RIO GRANDE WESTERN R.R.

FLAT CARS No's. 22231, 22233

AAR MECHANICAL DESIGNATION = FMS

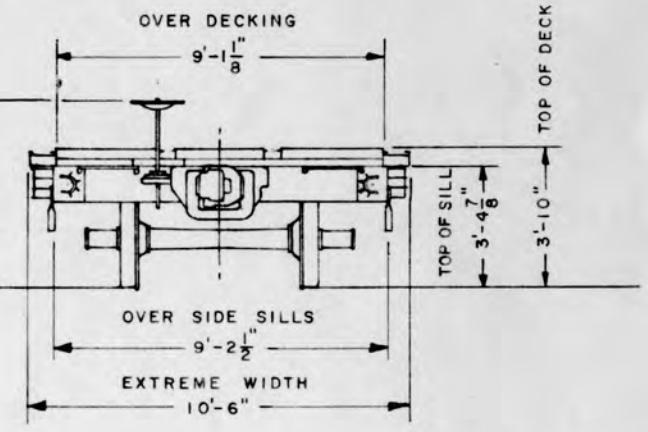
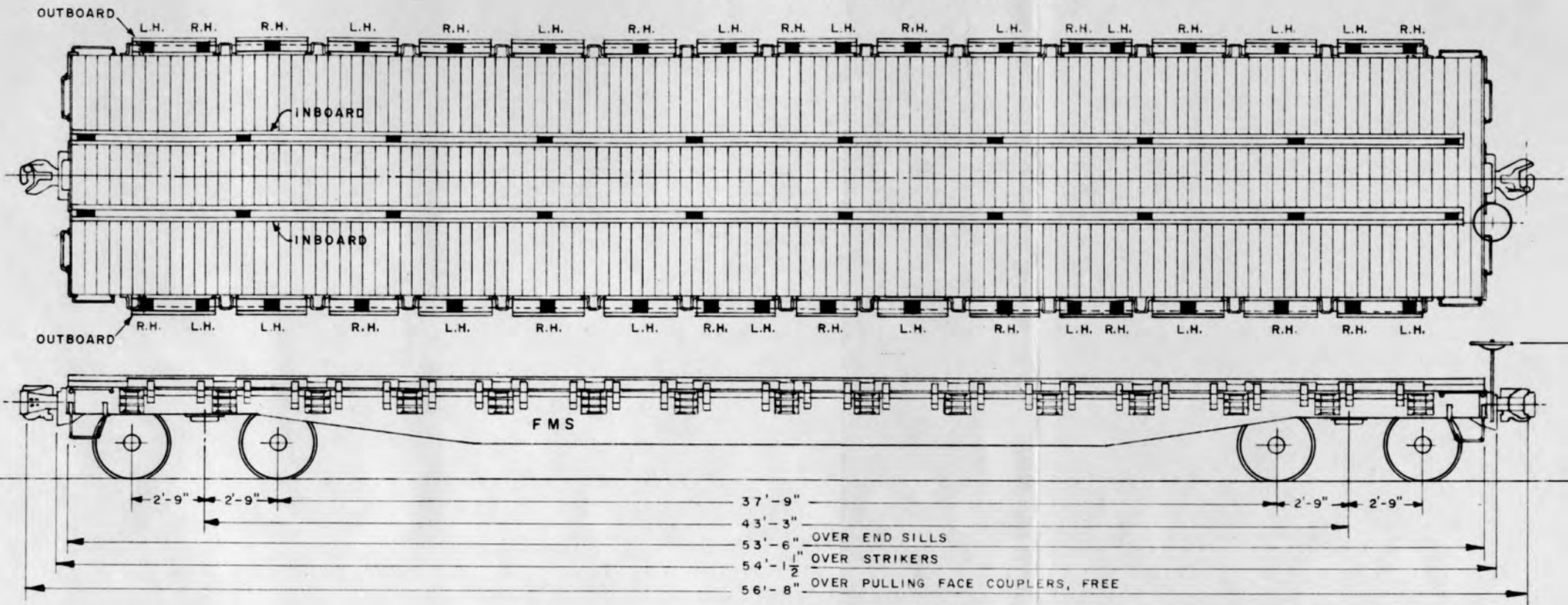

DESCRIPTION

GAUGE	4'-8 1/2"
JOURNALS	5 1/2" x 10"
WHEELS	33" WROT STEEL I-W
TRUCK TYPE	ASF A-3 RIDE CONTROL, 3/16" SPRING TRAVEL
TRUCK SIDES	CAST STEEL - INTEGRAL BOXES
SIDE BEARINGS	STUCKI
LOAD TIE-DOWN DEVICE	BRANDON
TIE-DOWN COMPLEMENT	
CHAIN ASSEMBLY WITH COMPRESSION UNIT - INBOARD	20
CHAIN ASSEMBLY WITH COMPRESSION UNIT - OUTBOARD	36
WINCH ASSEMBLY - INBOARD	20
WINCH ASSEMBLY - OUTBOARD (R.H.)	18
WINCH ASSEMBLY - OUTBOARD (L.H.)	18

DECKING	WOOD
UNDERFRAME	STEEL
DRAFT GEAR	CARDWELL - WESTINGHOUSE NY-II-F
COUPLER	AAR TYPE E
BRAKE	AB
HAND BRAKE	UNIVERSAL DROP SHAFT
BRAKE SLACK ADJUSTER	PNEUMATIC-AJAX

MARKED CAPACITY, LBS.	110,000
LIGHT WEIGHT, LBS. - 22231	55,100
MAXIMUM WEIGHT OF LADING, LBS. - 22231	121,900
LIGHT WEIGHT, LBS. - 22233	54,800
MAXIMUM WEIGHT OF LADING, LBS. - 22233	122,200
LENGTH OVER DECKING	53'-6"
WIDTH OVER DECKING	9'-1 1/8"
YEAR BUILT	1951
BUILDER	D & R G W
LOAD TIE-DOWN DEVICE APPLIED BY D & R G W	1965

REISSUE
 JAN. 2, 1959.
 JAN. 2, 1963.
 JULY 1, 1964.
 JAN. 2, 1965.

DENVER & RIO GRANDE WESTERN R.R.
 TRAILER FLAT CARS No's. 21500 to 21548

F-135

AAR MECHANICAL DESIGNATION = FC

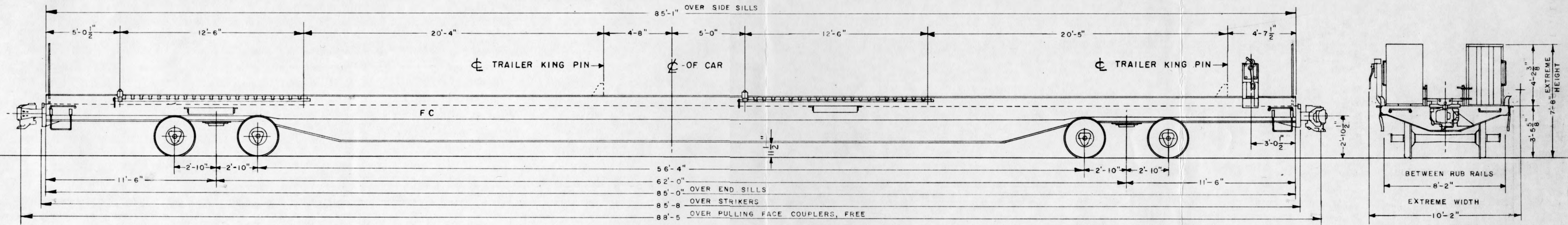

DESCRIPTION

GAUGE -----	4'-8 $\frac{1}{2}$ "	CONSTRUCTION -----	ALL WELDED- STEEL	MARKED CAPACITY, LBS. -----	130,000
JOURNALS -----	6" X 11" - TIMKEN ROLLER BEARINGS	UNDERFRAME -----	STEEL	LIGHT WEIGHT, LBS., AV. (21500-21523) -----	71,600
WHEELS (EXCEPT 21508) -----	33" WROT STEEL I-W	DRAFT GEAR -----	MINER FR-19-F	MAXIMUM WEIGHT OF LADING, LBS., AV. (21500-21523) -----	138,400
WHEELS (21508) -----	33" WROT STEEL M-W	COUPLER -----	INTERLOCKING - AAR TYPE F	LIGHT WEIGHT, LBS., AV. (21524-21548) -----	70,300
AXLES -----	D-6-D	BRAKE -----	AB 1012	MAXIMUM WEIGHT OF LADING, LBS., AV. (21524-21548) -----	139,700
TRUCK TYPE -----	ASF A-3 RIDE CONTROL	BRAKE CYLINDER RELEASE VALVE (21524-21548) -----	QRB	LENGTH OVER DECK -----	85'-0"
SPRING TRAVEL -----	3 $\frac{11}{16}$ "	BRAKE SLACK ADJUSTER -----	AMERICAN S.A.B. CO. - TYPE DRV-2	WIDTH OVER DECK -----	8'-2"
TRUCK SIDES (21500-21523) - SYMINGTON -----	NARROW PEDESTAL TYPE	HAND BRAKE -----	UNIVERSAL - PUMP HANDLE	YEAR BUILT (21500-21523) -----	1959
TRUCK SIDES (21524-21548) - NATIONAL CASTING CO. -----	NARROW PEDESTAL TYPE	RETRACTABLE TRAILER HITCHES-2 -----	AMERICAN CAR & FOUNDRY CO.	YEAR BUILT (21524-21548) -----	1963
TRUCK BOLSTER -----	CAST STEEL			BUILDERS -----	PULLMAN STANDARD CAR MFG. CO.
SIDE BEARINGS -----	PULLMAN-ROLLER				
BRAKE BEAMS - UNIT TYPE -----	CRECO-NO. 18				

DENVER & RIO GRANDE WESTERN R.R.
 AUTOMOBILE RACK CARS No's. 21700 to 21759
 AAR MECHANICAL DESIGNATION = FA

F-140

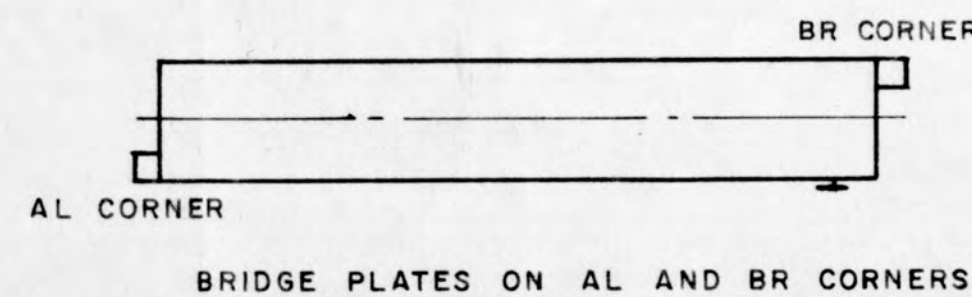
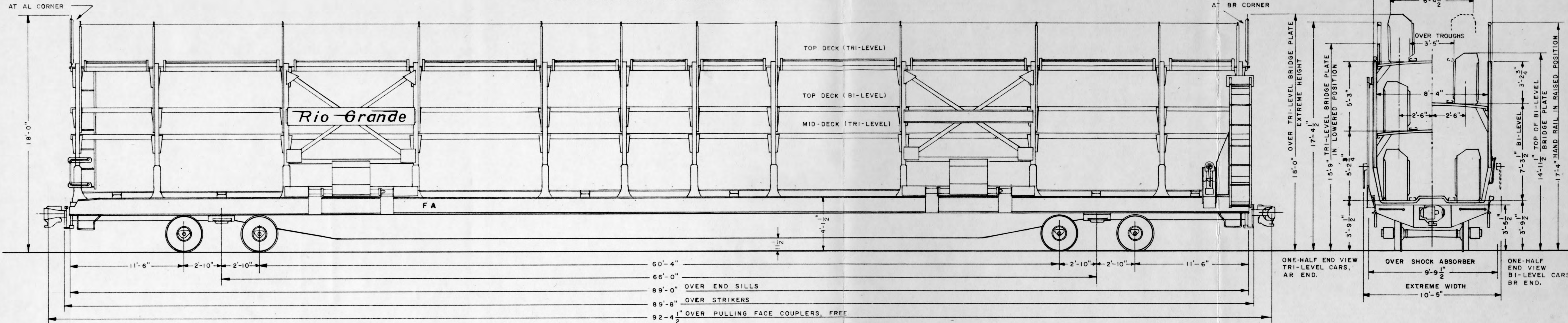

DESCRIPTION

GAUGE _____ 4'-8 1/2"
 JOURNALS _____ TIMKEN 6" X 11" ROLLER BEARINGS
 WHEELS _____ 33" WROT STEEL 1-W
 TRUCK TYPE _____ ASF A-3 RIDE CONTROL, 3 11/16" SPRING TRAVEL
 TRUCK SIDES _____ NARROW PEDESTAL TYPE
 TRUCK BOLSTER _____ CAST STEEL
 SIDE BEARINGS _____ STUCKI ROLLER
 UNIT TYPE BRAKE BEAMS _____ DAVIS NO. 18

BI-LEVEL CARS — NO'S. 21702, 21704, 21705, 21706, 21729, 21730, 21735,
 21737, 21740, 21743, 21746.

TRI-LEVEL CARS — REMAINING 49 CARS.

SUPERSTRUCTURE (RACKS-WHITEHEAD AND KALES) _____ FABRICATED STEEL

UNDERFRAME (FISH BELLY CENTER SILL) _____ BUILT UP-STEEL

DRAFT GEAR _____ CARDWELL-WESTINGHOUSE - MARK 50
 COUPLER _____ INTERLOCKING- AAR TYPE F
 BRAKE _____ AB 1012
 HAND BRAKE _____ ELLCON NATIONAL

BRAKE SLACK ADJUSTER _____ ELLCON NATIONAL - TYPE 1340-4

MARKED CAPACITY, LBS. _____ 130,000
 LIGHT WEIGHT, LBS., AV. (CAR WITHOUT RACKS) _____ 63,100
 MAX. WEIGHT OF LADING, LBS., (INCLUDING RACKS) _____ 135,000
 LIGHT WEIGHT, LBS., AV. (CARS WITH BI-LEVEL RACKS) _____ 91,000
 LIGHT WEIGHT, LBS., AV. (CARS WITH TRI-LEVEL RACKS) _____ 101,800

LENGTH OVER DECKS _____ 88'-10"
 WIDTH OVER DECKS _____ 8'-4"

YEAR BUILT (RACKS) _____ 1963
 BUILDERS (RACKS) _____ WHITEHEAD AND KALES
 YEAR BUILT (CAR ONLY) _____ 1963
 BUILDERS (CAR ONLY) _____ BETHLEHEM STEEL CO.

DENVER & RIO GRANDE WESTERN R.R.
 BULKHEAD FLAT CARS—TANK TRANSPORT
 No's. 20020 to 20024

AAR MECHANICAL DESIGNATION = FMS

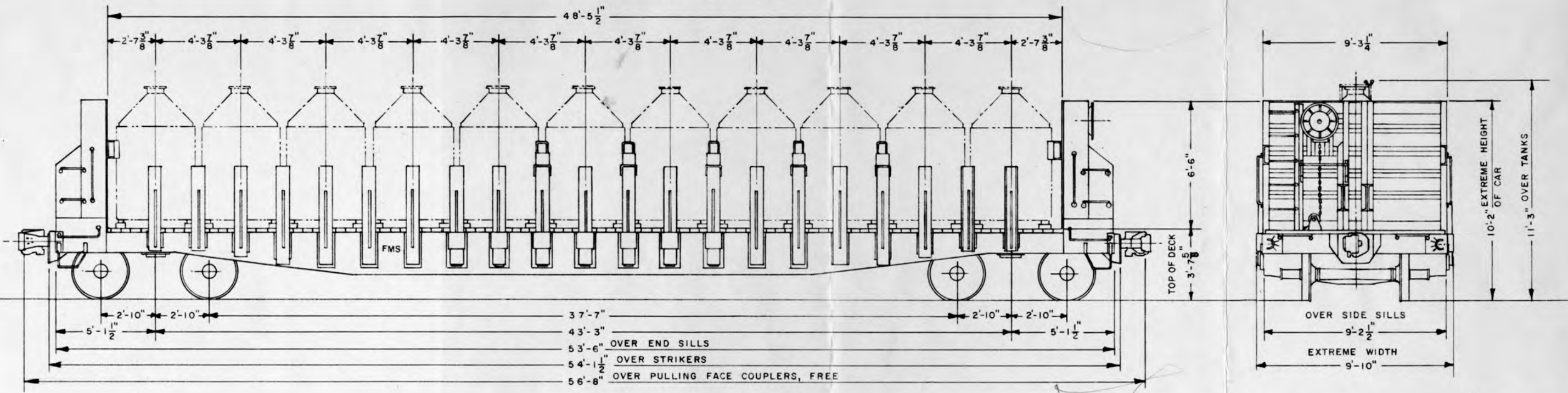

DESCRIPTION

GAUGE	4'-8 1/2"
JOURNALS	6" x 11"
WHEELS	33" WROT STEEL 1-W
TRUCK TYPE	TRUCK ASSOCIATION—SPRING PLANK
TRUCK SIDES	CAST STEEL—INTEGRAL BOXES
TRUCK BOLSTER	CAST STEEL
SIDE BEARINGS	STUCKI
REMOVABLE SIDE POSTS (8" CHANNEL)	14
REMOVABLE TANK LEG RETAINER RINGS	44
CROSSBARS	10
CONTAINER CAPACITY (48" DIA. TANKS)	22

UNDERFRAME (FISHBELLY CENTER & SIDE SILLS)	STEEL
DRAFT GEAR	CARDWELL—WESTINGHOUSE NY-II-F
COUPLER	AAR TYPE E
BRAKE	AB
HAND BRAKE	VERTICAL WHEEL NON-SPIN TYPE
BRAKE SLACK ADJUSTER	PNEUMATIC—AJAX

MARKED CAPACITY, LBS.	118,000
LIGHT WEIGHT, LBS., AV. (INCLUDING TANKS)	85,100
MAX. WEIGHT OF LADING, LBS., AV.	120,000
LIGHT WEIGHT (WITHOUT TANKS), LBS., AV.	73,100

LENGTH OVER DECK	48'-5"
WIDTH OVER DECK	9'-1 1/2"

20020	FORMERLY	22367	FORMERLY	22289	ORIGINALLY	22219
20021	"	22368	"	22292	"	22234
20022	"	22369	"	22250	"	22221
20023	"	22370	"	22291	"	22232
20024	"	22453	"		"	22246

YEAR BUILT AS FLAT CARS	1951
BUILDER	D&RGW
REBUILT AS BULKHEAD FLAT CARS BY D&RGW	1951-1954
REMODELED FOR CONTAINER SERVICE BY D&RGW	1964

DENVER & RIO GRANDE WESTERN R.R.
 BULKHEAD FLAT CARS—TANK TRANSPORT
 No's. 20020 to 20024

F-150

30207

AAR MECHANICAL DESIGNATION = FMS

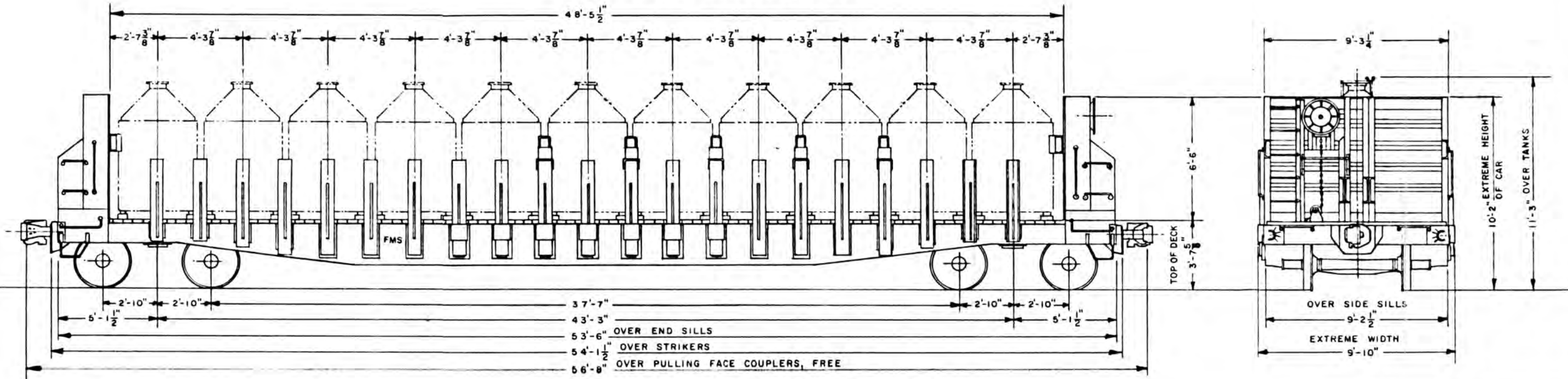

DESCRIPTION

GAUGE	4'-8 1/2"
JOURNALS	6" X 11"
WHEELS	33" WROT STEEL 1-W
TRUCK TYPE	TRUCK ASSOCIATION—SPRING PLANK
TRUCK SIDES	CAST STEEL—INTEGRAL BOXES
TRUCK BOLSTER	CAST STEEL
SIDE BEARINGS	STUCKI
REMOVABLE SIDE POSTS (8" CHANNEL)	14
REMOVABLE TANK LEG RETAINER RINGS	44
CROSSBARS	10
CONTAINER CAPACITY (48" DIA. TANKS)	22

UNDERFRAME (FISHBELLY CENTER & SIDE SILLS)	STEEL
DRAFT GEAR	CARDWELL—WESTINGHOUSE NY-II-F
COUPLER	AAR TYPE E
BRAKE	AB
HAND BRAKE	VERTICAL WHEEL NON-SPIN TYPE
BRAKE SLACK ADJUSTER	PNEUMATIC—AJAX

MARKED CAPACITY, LBS.	118,000
LIGHT WEIGHT, LBS., AV. (INCLUDING TANKS)	85,100
MAX. WEIGHT OF LADING, LBS., AV.	120,000
LIGHT WEIGHT (WITHOUT TANKS), LBS., AV.	73,100

LENGTH OVER DECK	48'-5 1/2"
WIDTH OVER DECK	9'-1 1/2"

	FORMERLY	22367	FORMERLY	22289	ORIGINALLY	22219
20020	"	22368	"	22292	"	22234
20021	"	22369	"	22250	"	22221
20022	"	22370	"	22291	"	22232
20023	"	22453	"		"	22246
20024	"		"		"	

YEAR BUILT AS FLAT CARS	1951
BUILDER	D&RGW
REBUILT AS BULKHEAD FLAT CARS BY D&RGW	1951-1954
REMODELED FOR CONTAINER SERVICE BY D&RGW	1964

DENVER & RIO GRANDE WESTERN R.R.
 ARTICULATED CONTAINER FLAT CARS No's. 20025-A&B to 20029-A&B

AAR MECHANICAL DESIGNATION = LF

FORMER NUMBER	PRESENT NUMBER
21038	20025-A
21055	20025-B
21084	20026-A
21026	20026-B
21086	20027-A
21053	20027-B
21030	20028-A
21020	20028-B
21097	20029-A
21070	20029-B

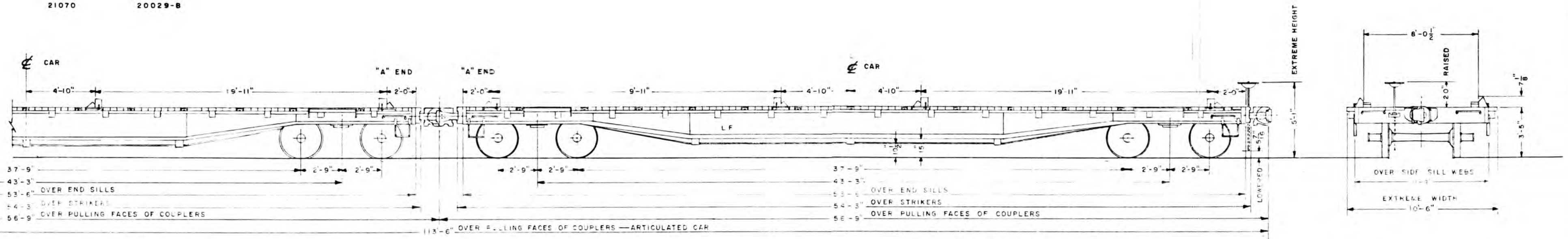

DESCRIPTION

GAUGE	4'-8 1/2"	CONSTRUCTION	WELDED	MARKED CAPACITY, LBS.	110,000
JOURNALS	5 1/2" x 10"	DECKING	2 3/4" OAK	LIGHT WEIGHT, LBS., AV. (EACH UNIT)	52,100
WHEELS (A-33)	33" WROT STEEL I-W	UNDERFRAME	BUILT-UP FISH BELLY CENTER SILL AND SIDE SILLS	MAXIMUM WEIGHT OF LADING, LBS., AV. (EACH UNIT)	124,900
AXLES	AAR M-101-57	DRAFT GEAR	MINER A-22-XL	LENGTH OVER DECKING	53'-6"
TRUCK TYPE	ASF A-3 RIDE CONTROL, 2 1/2" SPRING TRAVEL	COUPLER	6 1/4" x 8" SHANK, TYPE E HEAD	WIDTH OVER DECKING	10'-6"
TRUCK B DES	CAST STEEL- INTEGRAL BOXES	BRAKE	AB 1012	YEAR BUILT	1959
SIDE BEARINGS	STUCKI SINGLE ROLLER	HAND BRAKE	UNIVERSAL DROP SHAFT	MODIFIED FOR CONTAINER SERVICE BY D&RGW	1968
BRAKE BEAMS	UNIT TYPE NO. 18	CONTAINERS (20 FOOT)	2 EACH UNIT, 4 PER ARTICULATED CAR	BUILDER	BETHLEHEM STEEL CO.
BRAKE SHOES	1 1/2" - AAF ALTERNATE STANDARD	CONTAINER LOCKS	8 EACH UNIT, 16 PER ARTICULATED CAR		

DENVER & RIO GRANDE WESTERN R.R.
 BULKHEAD FLAT CARS-TANK TRANSPORT-NO'S. 20050 to 20053 & 20056

F-152
 30210 1

AAR MECHANICAL DESIGNATION = FM S

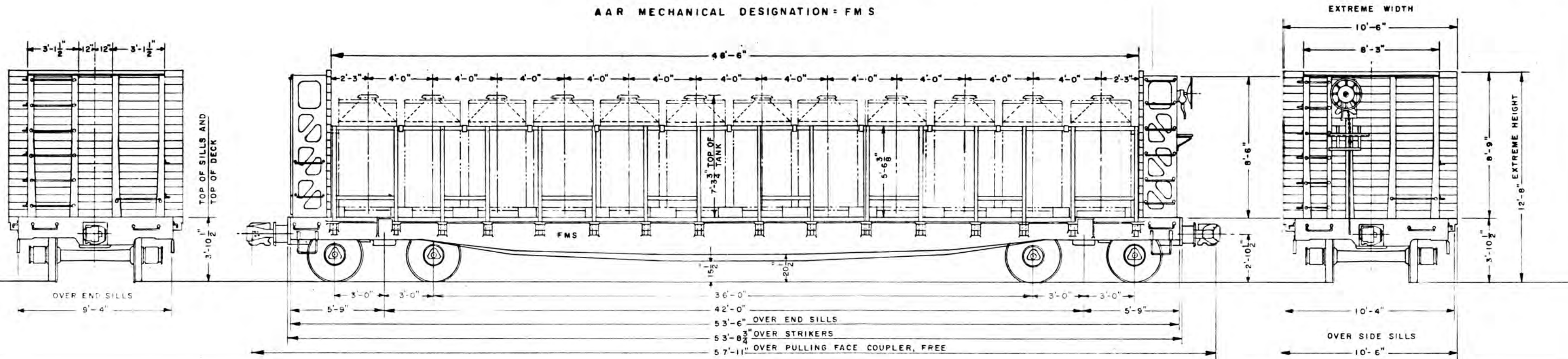

DESCRIPTION

GAUGE	4'-8 1/2"
JOURNALS	7" x 12" TIMKEN ROLLER BEARINGS
WHEELS (B-38)	38" WROT STEEL 1-W
AXLES	D-11-1965
TRUCK TYPE	BARBER STABILIZED S-2A, 2 1/2" SPRING TRAVEL
TRUCK SIDES	NARROW PEDESTAL TYPE
SIDE BEARINGS	DOUBLE ROLLER-STUCKI
BRAKE BEAMS	WABCO PAC B-4-9
BRAKE SHOES	COMPOSITION-COBR
REMOVABLE SIDE POSTS	32
REMOVABLE TANK LEG RETAINERS	33
CROSSBARS	11
TANKS (48" X 42"), WEIGHT 735 LBS. EACH	24

DECKING	3" X 10'-6" WOLMANIZED PINE
UNDERFRAME (FISHBELLY CENTER SILL AND SIDE SILLS)	CAST-NICKEL STEEL
SIDE FRAMING - POSTS AND RAILS	5" I BEAMS AT 10 LBS.
DRAFT GEAR	FREIGHT MASTER TYPE E-10" TRAVEL
COUPLER	(BE-60A-HT) 6 1/4" X 8" X 2 1/2" SHANK, TYPE E HEAD
BRAKE	WABCO PAC B-4-9 - 9" DIA. CYLINDER, J-1 REDUCTION RELAY VALVE-ABD
HAND BRAKE	ELLCON NATIONAL MODEL 850-1-NS
BRAKE STEP	APEX-STEEL

MARKED CAPACITY, LBS. (20052)	209,000
LIGHT WEIGHT, LBS. INCLUDING EMPTY TANKS (20052)	105,500
MAXIMUM WEIGHT OF LADING, LBS. (20052)	209,500
MARKED CAPACITY, LBS. (20050, 20051, 20053, 20056)	210,000
LIGHT WT., LBS., AV., INCLUDING EMPTY TANKS (20050, 20051, 20053, 20056)	103,600
MAXIMUM WEIGHT OF LADING, LBS., AV.	211,400
LENGTH OVER DECK	53'-6"
WIDTH OVER DECK	10'-6"
YEAR BUILT	1966
BUILDER	GENERAL STEEL INDUSTRIES, INC.

DENVER & RIO GRANDE WESTERN R.R.
BULKHEAD FLAT CARS No's. 20054 & 20055

F-153

AAR MECHANICAL DESIGNATION = FMS

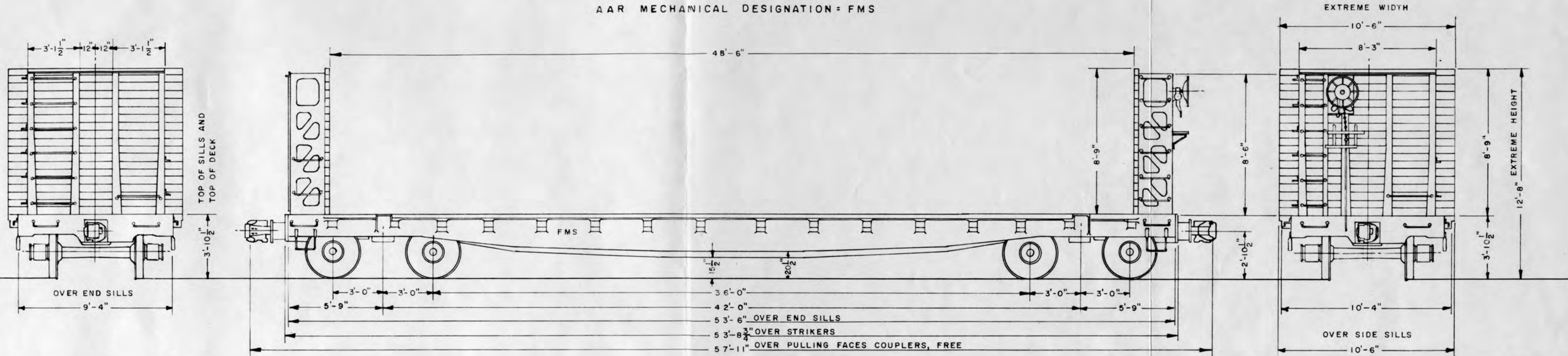

DESCRIPTION

GAUGE ----- 4'-8 1/2"
 JOURNALS ----- 7" X 12" TIMKEN ROLLER BEARINGS
 WHEELS (B-38) ----- 38" WROT STEEL I-W
 AXLES ----- D-11-65
 TRUCK TYPE ----- BARBER STABILIZED S-2A, 2 1/2" SPRING TRAVEL
 TRUCK SIDES ----- NARROW PEDESTAL TYPE
 SIDE BEARINGS ----- STUCKI DOUBLE ROLLER
 BRAKE BEAMS ----- WABCOPAC 9" CYLINDER
 BRAKE SHOES ----- COMPOSITION - COBRA

DECKING ----- 3" WOLMANIZED PINE
 UNDERFRAME (FISHBELLY CENTER SILL AND SIDE SILLS) ----- CAST NICKEL STEEL
 DRAFT GEAR ----- FREIGHT MASTER TYPE E-10" TRAVEL
 COUPLER ----- (BE-60A-HT) 6 1/4" X 8" X 21 1/2" SHANK, TYPE E HEAD
 BRAKE ----- WABCOPAC B-4-9, J-1 REDUCTION RELAY VALVE - ABD
 HAND BRAKE ----- ELLCON NATIONAL MODEL 850-1-NS
 BRAKE STEP ----- APEX

MARKED CAPACITY, LBS. (20054) ----- 185,000
 LIGHT WEIGHT, LBS. (20054) ----- 77,060
 MAXIMUM WEIGHT OF LADING, LBS. (20054) ----- 185,940

MARKED CAPACITY, LBS. (20055) ----- 186,000
 LIGHT WEIGHT, LBS. (20055) ----- 76,800
 MAXIMUM WEIGHT OF LADING, LBS. ----- 186,200

LENGTH OVER DECK ----- 53'-6"
 WIDTH OVER DECK ----- 10'-6"

YEAR BUILT AND ASSIGNED TO CONTAINER SERVICE ----- 1966
 ASSIGNED TO REGULAR SERVICE ----- JULY, 1968
 BUILDER ----- GENERAL STEEL INDUSTRIES, INC.

REISSUE
 JAN. 2, 1959
 SEPT. 1, 1959.
 JAN. 2, 1961.
 JAN. 2, 1963.
 JAN. 2, 1965.

DENVER & RIO GRANDE WESTERN R.R.
 BULKHEAD FLAT CAR No. 22317

F-154

AAR MECHANICAL DESIGNATION = FMS

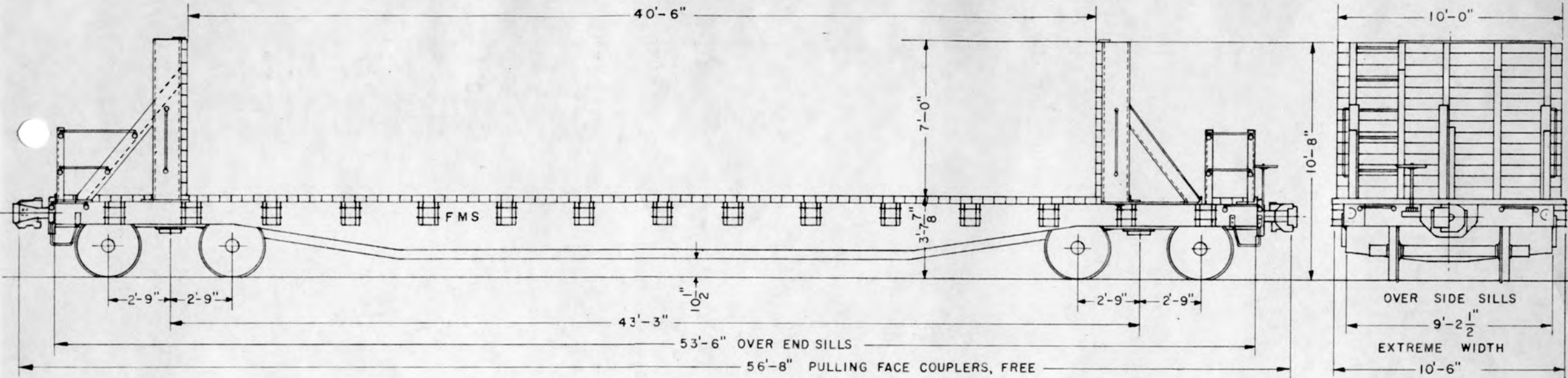

DESCRIPTION

GAUGE ----- 4'-8 1/2"
 JOURNALS ----- 5 1/2" X 10"
 WHEELS ----- 33" CAST IRON
 TRUCK TYPE ----- TRUCK ASS'N-SPRING PLANK
 SPRING TRAVEL ----- 2 1/2"

TRUCK SIDES ----- CAST STEEL-INTEGRAL BOXES
 TRUCK BOLSTER ----- CAST STEEL
 SIDE BEARINGS ----- STUCKI

UNDERFRAME ----- STEEL
 DECK ----- WOOD

DRAFT GEAR ----- CARDWELL-WESTINGHOUSE NY-II-F
 COUPLER ----- AAR TYPE E
 BRAKE ----- AB
 HAND BRAKE ----- UNIVERSAL DROP SHAFT
 BRAKE SLACK ADJUSTER ----- ROYAL TYPE F

MARKED CAPACITY, LBS. ----- 110,000
 LIGHT WEIGHT, LBS. ----- 54,000
 MAX. WEIGHT OF LADING, LBS. ----- 123,000
 LENGTH OVER DECKING ----- 40'-6"
 WIDTH OVER DECKING ----- 10'-6"

YEAR BUILT AS FM FLAT CAR NO. 22143 ----- 1944

BUILDERS ----- MT. VERNON CAR MFG. CO.

REBUILT AS BULKHEAD FLAT CAR BY D & R G W ----- 1954

REISSUE
 JAN. 2, 1959.
 SEPT. 1, 1959.
 JAN. 2, 1961.
 JAN. 2, 1963.
 JAN. 2, 1965.

F-155

DENVER & RIO GRANDE WESTERN R. R. BULKHEAD FLAT CARS No's. 22330 to 22374

NO'S. 22333, 22335-22374 EQUIPPED WITH TAPE CEMENT LOCKERS

AAR MECHANICAL DESIGNATION = FMS

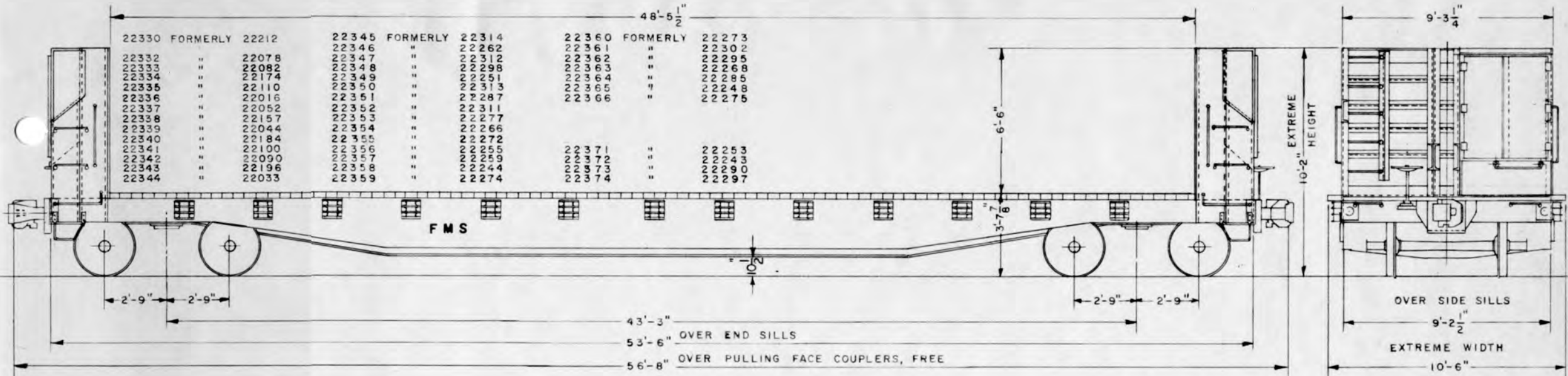

DESCRIPTION

GAUGE ----- 4'-8 1/2"	UNDERFRAME ----- STEEL	MARKED CAPACITY, LBS. ----- 110,000
JOURNALS ----- 5 1/2" X 10"	DRAFT GEAR ----- CARDWELL-WESTINGHOUSE NY-II-F	LT. WT, LBS., AV. (22330, 22332, 22334) ----- 56,500
WHEELS ----- 33" CAST IRON	COUPLER ----- AAR TYPE E	MAX. WT. OF LADING, LBS., AV. (22330, 22332, 22334) ----- 120,500
CARS NO'S. 22332-2344, 22346, 22349, 22351, 22353 TO 22357, 2360, 22363, 22364, 22366, 22371	BRAKE ----- AB	LT. WT, LBS., AV. (22333, 22335-22374) ----- 57,500
TRUCK TYPE ----- TRUCK ASSOCIATION-SPRING PLANK	HAND BRAKE ----- UNIVERSAL DROP SHAFT	MAX. WT. OF LADING, LBS., AV. (22333, 22335-22374) ----- 119,500
CARS NO'S. 22330, 2345, 22347, 22348, 22350, 22352, 22358, 2359, 22361, 22362, 22365, 22372, 22373, 2374	CARS NO'S. 22330, 22345, 22347, 22348, 22350, 22352, 22358, 22359, 22361, 22362, 22365, 22372, 22373, 22374	CUBICAL CAPY, CU. FT. (CEMENT LOCKERS) EACH ----- 58
TRUCK TYPE ----- ASF A-3 RIDE CONTROL	BRAKE SLACK ADJUSTER ----- PNEUMATIC-AJAX	CUBICAL CAPY, CU. FT. (CEMENT LOCKERS) PER CAR ----- 116
SPRING TRAVEL ----- 3 1/16"	CARS NO'S. 22332-22344, 22346, 22349, 22351, 22353 TO 22357, 22360, 22363, 22364, 22366, 22371	LENGTH OVER DECKING ----- 48'-5 1/2"
TRUCK SIDES ----- CAST STEEL-INTEGRAL BOXES	BRAKE SLACK ADJUSTER ----- ROYAL TYPE F	WIDTH OVER DECKING ----- 10'-6"
TRUCK BOLSTER ----- CAST STEEL		CARS NO'S. 22332-22344, 22346, 22349, 22351, 22353-22357, 22360, 22363, 22364, 22366, 22371
SIDE BEARINGS ----- STUCKI		YEAR BUILT AS FLAT CARS ----- 1944
		BUILDERS ----- MT. VERNON CAR MFG. CO.
		CARS NO'S. 22330, 22345, 22347, 22348, 22350, 22352, 22358, 22359, 22361, 22362, 22365, 22372, 22373, 22374
		YEAR BUILT AS FLAT CARS ----- 1951
		BUILDERS ----- D & R G W
		REBUILT AS BULKHEAD FLAT CARS BY D & R G W ----- 1951-1956

DENVER & RIO GRANDE WESTERN R.R.
 BULKHEAD FLAT CARS No's. 22375 to 22424

(EQUIPPED WITH TAPE CEMENT LOCKERS)

AAR MECHANICAL DESIGNATION=FMS

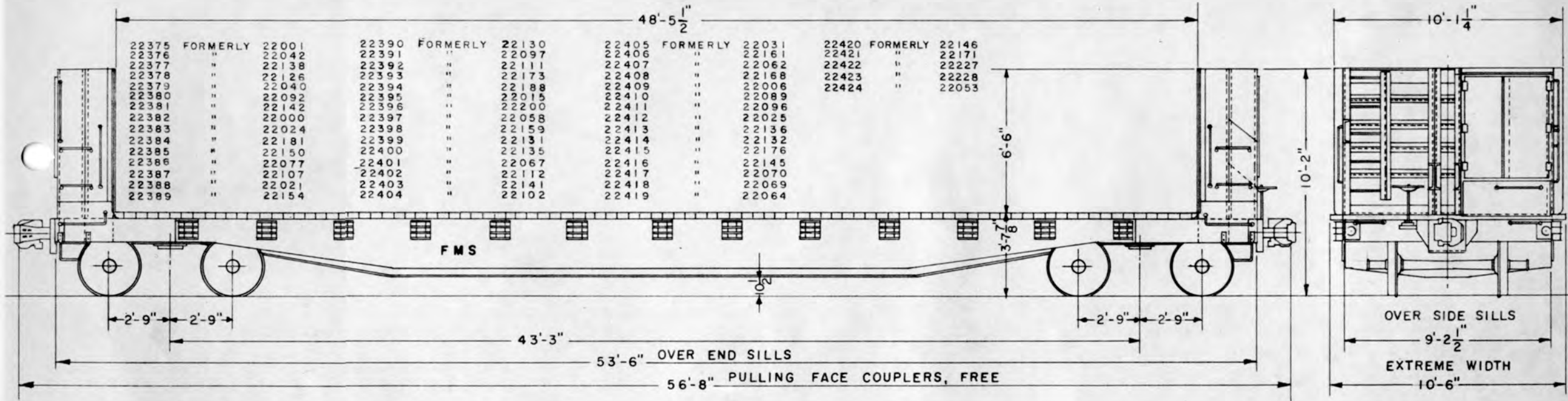

DESCRIPTION

GAUGE ----- 4'-8 1/2"
 JOURNALS ----- 5 1/2" X 10"
 WHEELS ----- 33" CAST IRON

EXCEPT 22396, 22422, 22423

TRUCK TYPE --- TRUCK ASSOCIATION - SPRING PLANK

22396, 22422, 22423

TRUCK TYPE --- { ASF A-3 RIDE CONTROL,
 SPRING PLANKLESS,
 3 1/16" SPRING TRAVEL

TRUCK SIDES ----- CAST STEEL - INTEGRAL BOXES
 TRUCK BOLSTER ----- CAST STEEL
 SIDE BEARINGS ----- STUCKI

UNDERFRAME ----- STEEL

DRAFT GEAR ----- CARDWELL-WESTINGHOUSE NY-II-F
 COUPLER ----- AAR TYPE E
 BRAKE ----- AB
 HAND BRAKE ----- UNIVERSAL DROP SHAFT

BRAKE SLACK ADJUSTER (EXCEPT 22396, 22422, 22423) - ROYAL TYPE F
 BRAKE SLACK ADJUSTER (22396, 22422, 22423) - PNEU-AJAX

MARKED CAPACITY, LBS. ----- 110,000
 LIGHT WEIGHT, LBS., AV. ----- 57,800
 MAX. WEIGHT OF LADING, LBS., AV. ----- 119,200
 CUBICAL CAPACITY, CU. FT., (CEMENT LOCKERS) EACH-53

LENGTH OVER DECKING ----- 48'-5 1/2"
 WIDTH OVER DECKING ----- 10'-6"

YEAR BUILT { AS FLAT CARS,
 EXCEPT 22396, 22422, 22423 } ----- 1944

YEAR BUILT (AS FLAT CARS) 22396, 22422, 22423 ----- 1951
 BUILDERS (EXCEPT 22396, 22422, 22423) - MT. VERNON CAR MFG. CO.
 BUILDERS (22396, 22422, 22423) ----- D & R G W

REBUILT AS BULKHEAD FLAT CARS BY D & R G W ----- 1958, 1959

DENVER & RIO GRANDE WESTERN R. R.
BULKHEAD FLAT CARS No's. 22425 to 22473

(EQUIPPED WITH TAPE CEMENT LOCKERS)

AAR MECHANICAL DESIGNATION = FMS

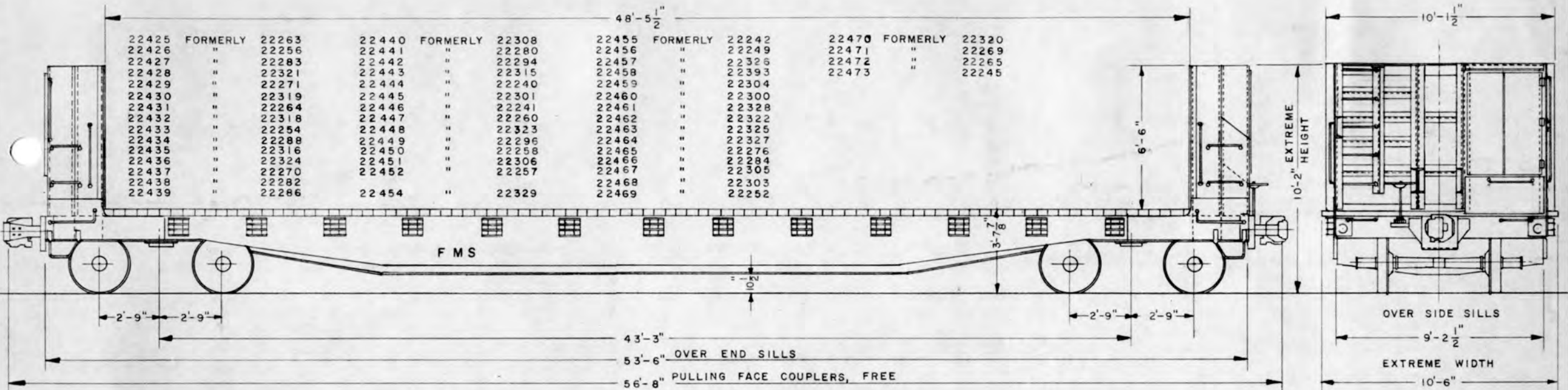

DESCRIPTION

GAUGE ----- 4'-8 ¹ / ₂ "	MARKED CAPACITY, LBS. ----- 110,000
JOURNALS ----- 5 ¹ / ₂ " X 10"	LIGHT WEIGHT, LBS., AV. ----- 58,300
WHEELS ----- 33" CAST IRON	MAX. WEIGHT OF LADING, LBS., AV. ----- 118,700
TRUCK TYPE	CUBICAL CAPY., CU. FT. (CEMENT LOCKERS) EACH ----- 52
TRUCK ASSOCIATION ----- SPRING PLANK	LENGTH OVER DECKING ----- 48'-5 ¹ / ₂ "
22425-22433, 22435-22439, 22441, 22443, 22447, 22448, 22450, 22452, 22454, 22457, 22461-22466, 22469, 22471, 22472,	WIDTH OVER DECKING ----- 10'-6"
TRUCK TYPE	YEAR BUILT (AS FLAT CARS) ----- 1944
ASF A-3 RIDE CONTROL ----- 3 ¹ / ₁₆ " SPRING TRAVEL	BUILDERS ----- MT. VERNON CAR MFG. CO.
22434, 22440, 22442, 22444, 22445, 22446, 22449, 22451, 22455, 22456, 22458, 22459, 22460, 22467, 22468, 22470, 22473.	22425-22433, 22435-22439, 22441, 22443, 22447, 22448, 22450, 22452, 22454, 22457, 22461-22466, 22469, 22471, 22472
TRUCK SIDES ----- CAST STEEL - INTEGRAL BOXES	YEAR BUILT (AS FLAT CARS) ----- 1951
TRUCK BOLSTER ----- CAST STEEL	BUILDERS ----- D&RGW
SIDE BEARINGS ----- STUCKI	22434, 22440, 22442, 22444, 22445, 22446, 22449, 22451, 22455, 22456, 22458, 22459, 22460, 22467, 22468, 22470, 22473
UNDERFRAME ----- STEEL	REBUILT AS BULKHEAD FLAT CARS BY D&RGW -- 1951-1955
DRAFT GEAR ----- CARDWELL - WESTINGHOUSE NY-II-F	
COUPLER ----- AAR TYPE E	
BRAKE ----- AB	
HAND BRAKE ----- UNIVERSAL - DROP SHAFT	
BRAKE SLACK ADJUSTER ----- ROYAL TYPE F	
22425-22433, 22435-22439, 22441, 22443, 22447, 22448, 22450, 22452, 22454, 22457, 22461-22466, 22469, 22471, 22472	
BRAKE SLACK ADJUSTER ----- PNEUMATIC - AJAX	
22434, 22440, 22442, 22444, 22445, 22446, 22449, 22451, 22455, 22456, 22458, 22459, 22460, 22467, 22468, 22470, 22473	

REISSUE
 JAN. 2, 1963.
 JAN. 2, 1963.
 JULY 1, 1964.
 JAN. 2, 1965.

DENVER & RIO GRANDE WESTERN R.R.
 BULKHEAD FLAT CARS No's. 22485 to 22661

F-158

(EQUIPPED WITH TAPE CEMENT LOCKER)

AAR MECHANICAL DESIGNATION = FMS

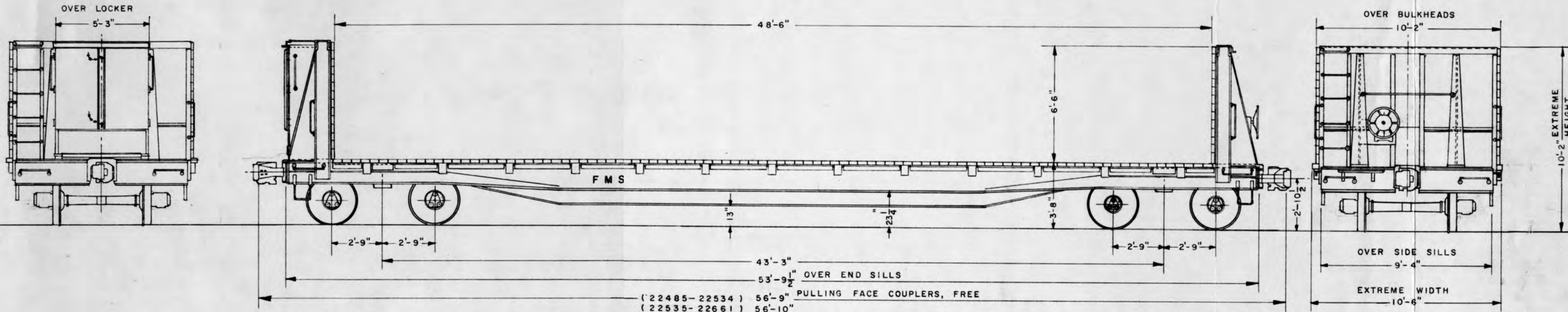

DESCRIPTION

GAUGE -----	4'-8 1/2"	MARKED CAPACITY, LBS. -----	110,000
JOURNALS (22485-22534, 22612-22661) --	5 1/2" X 10" TIMKEN ROLLER BEARINGS	LIGHT WEIGHT, LBS., AV. (22485-22534) -----	66,800
JOURNALS (22535-22611) -----	5 1/2" X 10" HYATT ROLLER BEARINGS	MAX. WEIGHT OF LADING, LBS., AV. (22485-22534) -----	110,200
WHEELS -----	33" ROLLED STEEL 1-W	LIGHT WEIGHT, LBS., AV. (22535-22661) -----	66,400
AXLES -----	D-6-C	MAX. WEIGHT OF LADING, LBS., AV. (22535-22661) -----	110,600
SPRING TRAVEL -----	2 1/2"	LIGHT WEIGHT, LBS., AV. (22562-22661) -----	66,200
TRUCK TYPE -----	ASF A-3 RIDE CONTROL	MAX. WEIGHT OF LADING, LBS., AV. (22562-22661) -----	110,800
TRUCK SIDES -----	NARROW PEDESTAL TYPE	CUBICAL CAPACITY, CU. FT. (CEMENT LOCKER) -----	80
TRUCK BOLSTER -----	CAST STEEL	LENGTH OVER DECKING -----	48'-6"
SIDE BEARINGS -----	STUCKI-ROLLER	WIDTH OVER DECKING -----	10'-6"
BRAKE BEAMS -----	AAR UNIT TYPE-NO. 18	YEAR BUILT (22485-22534) -----	1960
		YEAR BUILT (22535-22661) -----	1962
		YEAR BUILT (22562-22661) -----	1963
		BUILDERS -----	BETHLEHEM STEEL CO.
UNDERFRAME -----	STEEL		
DECKING (2 3/4 X 5 1/2 FACE) -----	OAK		
DRAFT GEAR (22485-22561) -----	CARDWELL-WESTINGHOUSE NY-II-F		
DRAFT GEAR (22562-22661) -----	CARDWELL-WESTINGHOUSE-MARK 50		
COUPLER -----	AAR TYPE E		
BRAKE -----	AB 1012		
HAND BRAKE -----	VERTICAL WHEEL-NON-SPIN-UNIVERSAL		
BRAKE SLACK ADJUSTER (22562-22661) -----	WESTINGHOUSE		

DENVER & RIO GRANDE WESTERN R.R.
BULKHEAD FLAT CARS No's. 22662 to 22761

(EQUIPPED WITH TAPE CEMENT LOCKER)

AAR MECHANICAL DESIGNATION = FMS

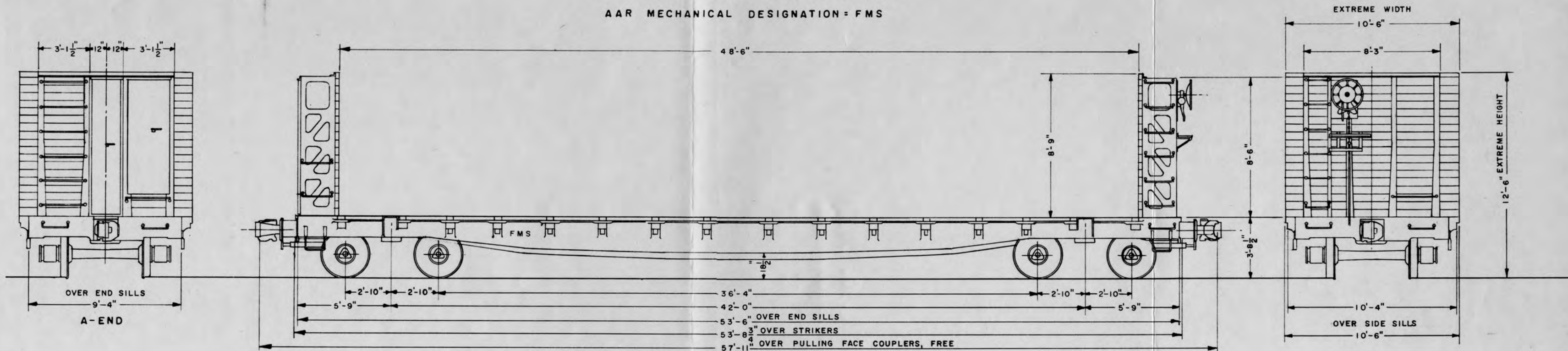

DESCRIPTION

GAUGE	4'-8 1/2"	BULKHEADS	CAST STEEL	MARKED CAPACITY, LBS.	140,000
JOURNALS	6" X 11" HYATT ROLLER BEARINGS	BULKHEAD FACING (3" X 5 5/8" BOARDS)	TREATED PINE	LIGHT WEIGHT, LBS., AV.	75,400
WHEELS (22662 - 22711)	33" CAST STEEL I-W	DECKING (3" X 5 5/8" BOARDS)	TREATED PINE	MAXIMUM WEIGHT OF LADING, LBS., AV.	144,600
WHEELS (22712 - 22761)	33" WROT STEEL I-W	TIE-DOWN DEVICES (BRANDON)	28		
AXLES	D-6-D	UNDERFRAME	CAST STEEL	CUBICAL CAPACITY, CU. FT. (CEMENT LOCKER)	70
TRUCK TYPE	ASF A-3 RIDE CONTROL, 2 1/2" SPRING TRAVEL	DRAFT GEAR	FREIGHTMASTER TYPE E-10" TRAVEL	LENGTH OVER DECKING	48'-6"
TRUCK SIDES	NARROW PEDESTAL TYPE	COUPLER	2 1/2" SHANK, AAR TYPE E	WIDTH OVER DECKING	10'-6"
SIDE BEARINGS	STUCKI-ROLLER	BRAKE	ABD 1012		
BRAKE BEAMS	UNIT TYPE NO. 18	BRAKE SLACK ADUSTER	PEACOCK-MODEL 1340-4		
		HAND BRAKE	VERTICAL WHEEL-NON-SPIN-MINER		
		BRAKE STEP	APEX-STEEL	YEAR BUILT	1965
				BUILDER	GENERAL STEEL INDUSTRIES, INC.

DENVER & RIO GRANDE WESTERN R. R.
 TANK CAR No. 19109

F-170

AAR MECHANICAL DESIGNATION=TM
 (FORMERLY D & S L NO. 11017)

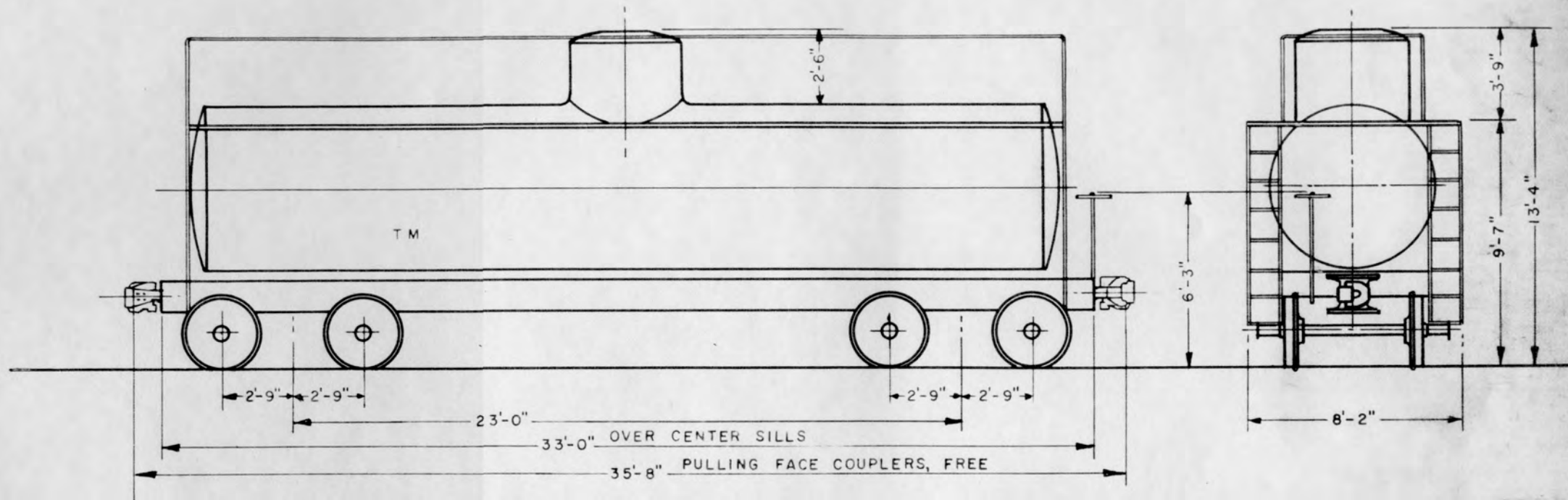

DESCRIPTION

GAUGE ----- 4'-8 ¹ / ₂ "	TANK ----- STEEL	MARKED CAPACITY, LBS. ----- 88,000
JOURNALS ----- 5" X 9"		LIGHT WEIGHT, LBS. ----- 38,300
WHEELS ----- 33" CAST IRON		MAX. WEIGHT OF LADING, LBS. ----- 103,700
TRUCK SIDES ----- CAST STEEL-INTEGRAL BOXES	UNDERFRAME ----- STEEL	CAPACITY OF TANK, GALS. ----- 8,177
TRUCK BOLSTER ----- BUILT UP-STEEL		CAPACITY OF DOME, GALS. ----- 145
	DRAFT GEAR ----- CARDWELL B-9	LENGTH INSIDE ----- 29'-8"
	BRAKE ----- AB	INSIDE DIA.-TANK ----- 6'-11"
	HAND BRAKE ----- HORIZONTAL WHEEL	INSIDE DIA.-DOME ----- 3'-8"
		INSIDE HEIGHT-DOME ----- 22"
		YEAR BUILT ----- 1908
	HEATER COILS ----- YES	

DENVER & RIO GRANDE WESTERN R.R.
 TANK CARS No's. 19200 to 19214

AAR MECHANICAL DESIGNATION = TA

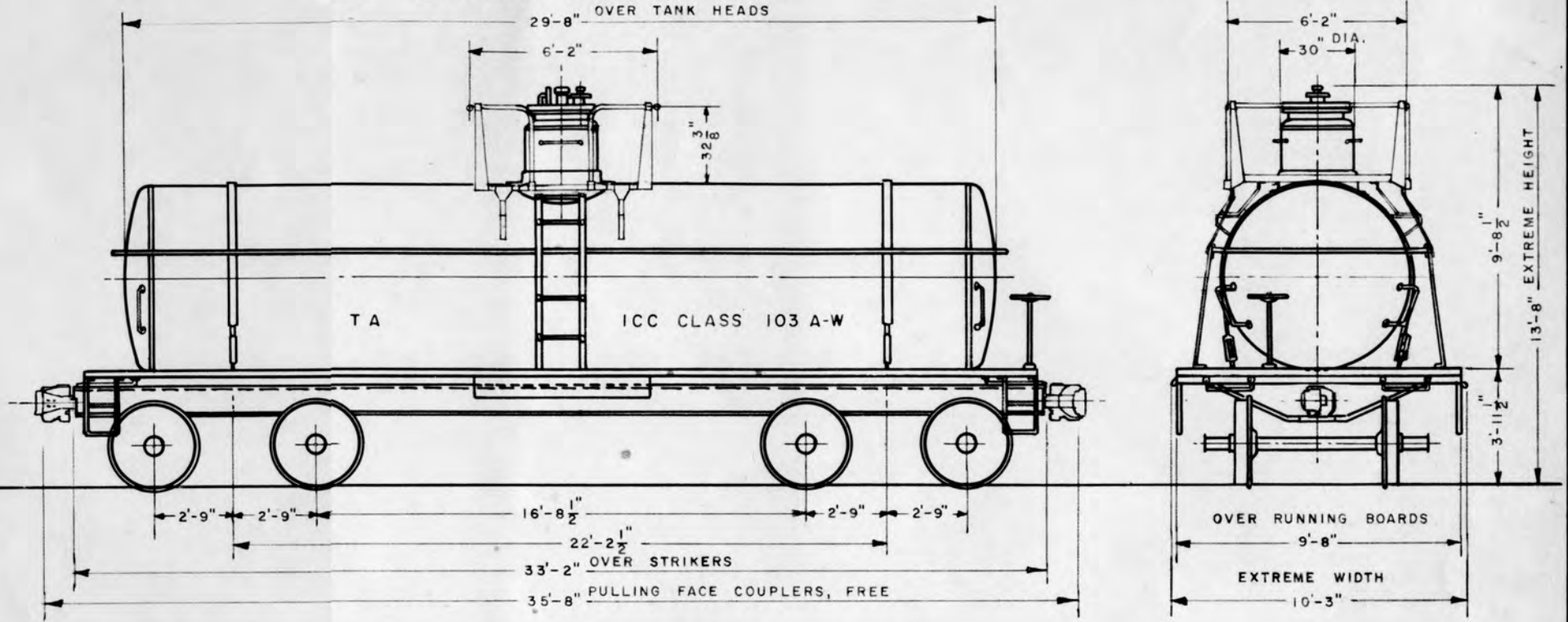

DESCRIPTION

GAUGE ----- 4'-8 1/2"	TANK ----- FUSION WELDED-STEEL	MARKED CAPACITY, LBS. ----- 110,000
JOURNALS ----- 5 1/2" X 10"	UNDERFRAME ----- WELDED-STEEL	LIGHT WEIGHT, LBS., AV. ----- 40,600
WHEELS ----- 33" WROT STEEL 1-W	DRAFT GEAR ----- CARDWELL-WESTINGHOUSE NY-II-F	MAX. WEIGHT OF LADING, LBS., AV. ----- 136,400
TRUCK TYPE ----- { BARBER STABILIZED TYPE S-2 SPRING PLANKLESS	COUPLER ----- AAR TYPE E	CAPACITY OF TANK, GALS. ----- 7,000
TRUCK SIDES ----- CAST STEEL-INTEGRAL BOXES	BRAKE ----- AB	CAPACITY OF DOME, GALS. ----- 75
TRUCK BOLSTER ----- CAST STEEL	HAND BRAKE ----- SUPERIOR-HORIZONTAL WHEEL	LENGTH INSIDE ----- 29'-7"
UNIT TYPE BRAKE BEAMS ----- UNIT TRUCK CORP.	SAFETY VALVES -----	INSIDE DIAMETER - TANK ----- 6'-5"
	HEATER COILS ----- NONE	INSIDE DIAMETER - DOME ----- 2'-5 1/4"
		YEAR BUILT ----- 1948
		BUILDERS ----- GEN. AMERICAN TRANSPORTATION CORP.
		DOMES PLATFORM ADDED ----- 1960

DENVER & RIO GRANDE WESTERN R.R.
 CABOOSSES No. 01400 to 01409

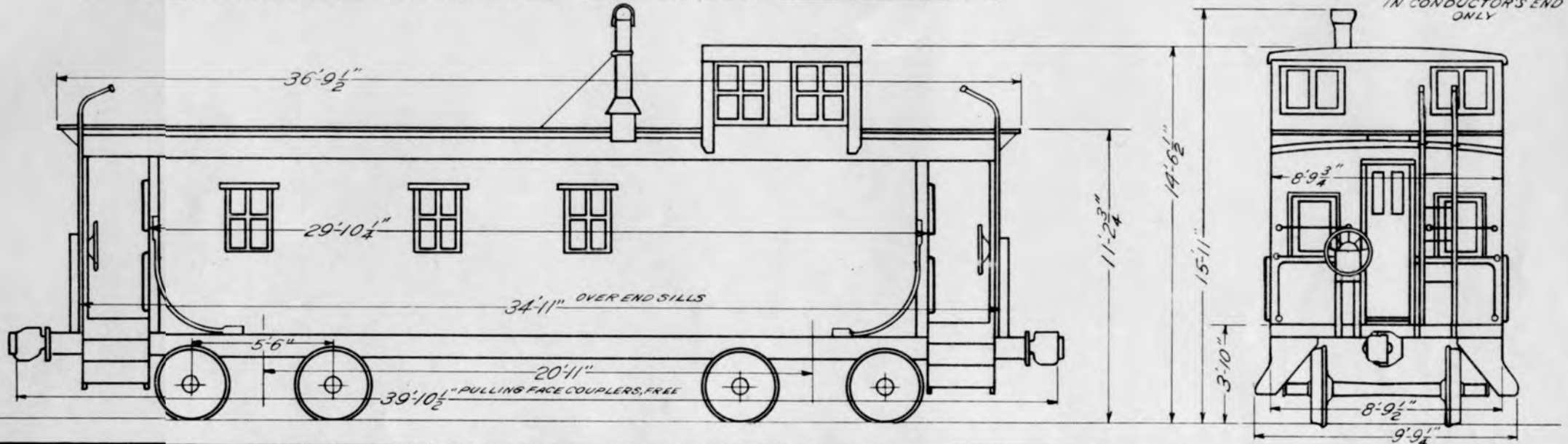
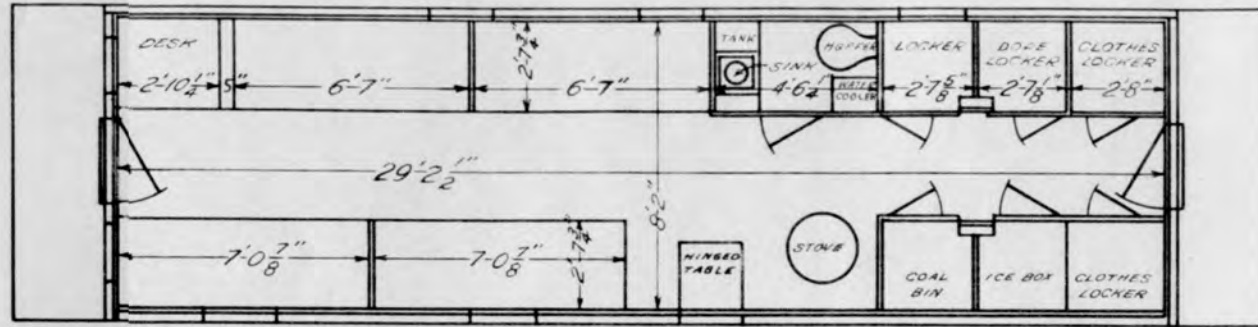

DESCRIPTION

GAUGE	4'-8 1/2"	ROOF	STEEL	LIGHT WEIGHT, LBS.	47,000
JOURNALS	4 1/4" x 8"	ENDS	STEEL	LENGTH INSIDE	29'-2 1/2"
WHEELS	33" CAST IRON	SIDES	STEEL	WIDTH INSIDE	8'-2"
TRUCK TYPE	BETTENDORF SWING	UNDERFRAME	STEEL-DURYEA	HEIGHT INSIDE AT CENTER	6'-9 1/16"
TRUCK SIDES	CAST STEEL-INTEGRAL BOXES	DRAFT GEAR	DURYEA	YEAR BUILT	1940
TRUCK BOLSTER	CAST STEEL	COUPLER	AAR TYPE E	BUILDERS	D.&R.G.W.
SIDE BEARINGS	BARBER	BRAKE	AB		
		HAND BRAKE	AJAX		
		LINING & CEILING	PLYWOOD		
		INSULATION IN FLOOR, SIDES, ENDS, & CEILING			
		RUNNING BOARDS	STEEL		
		BRAKE GEAR REGULATOR	ROYAL TYPE F		

DENVER & RIO GRANDE WESTERN R.R.

CABOOSSES No. 01410 to 01429

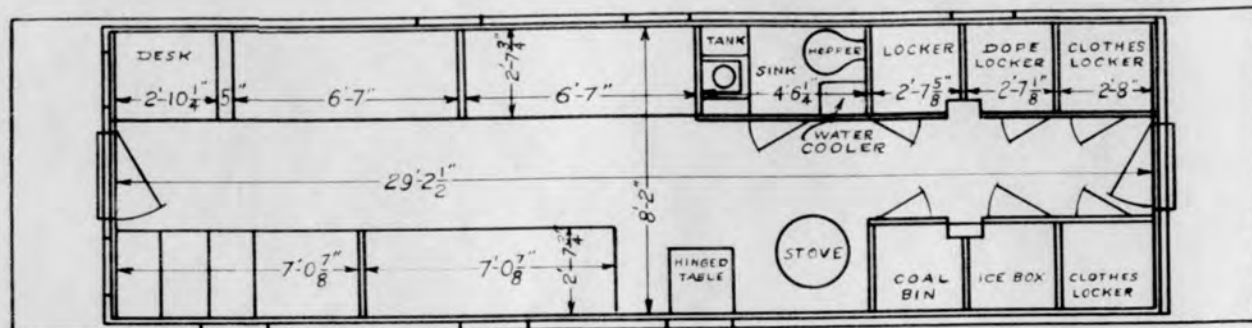

FOLDING SEAT TO FACE END WINDOW

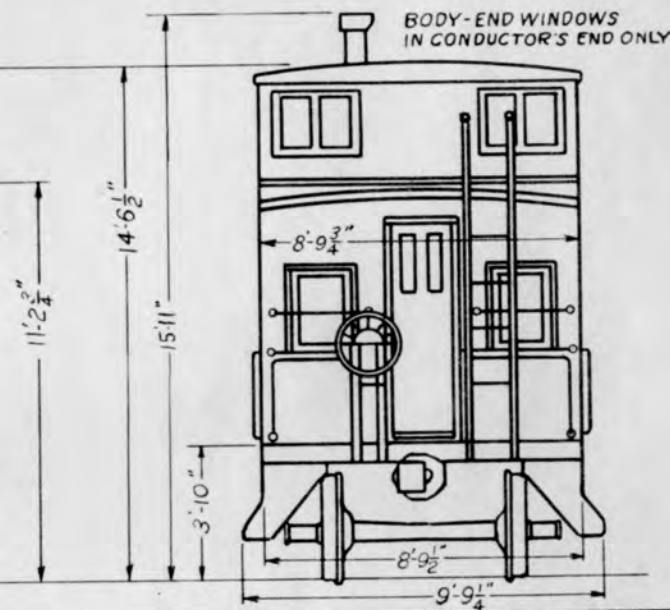
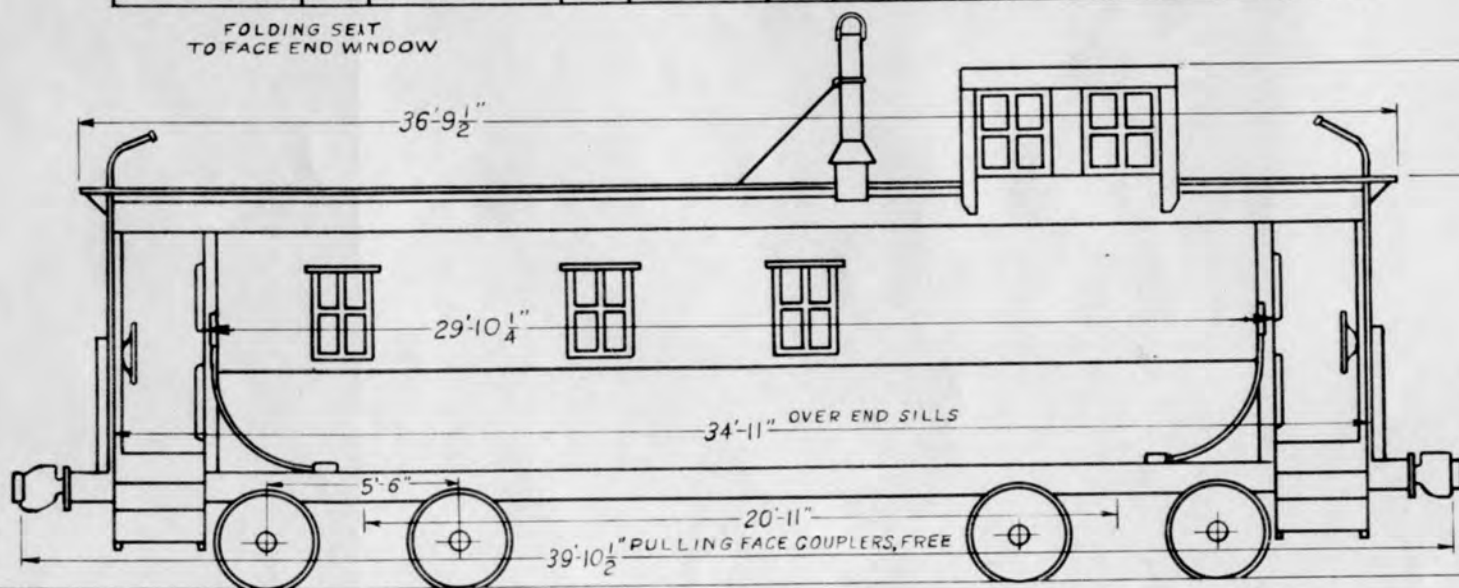

DESCRIPTION

GAUGE	4'-8 1/2"
JOURNALS	4 1/4" x 8"
WHEELS	33" CAST IRON
TRUCK TYPE	BETTENDORF SWING
TRUCK SIDES	CAST STEEL-INTEGRAL BOXES
TRUCK BOLSTER	CAST STEEL
SIDE BEARINGS	BARBER

ROOF	STEEL
ENDS	STEEL
SIDES	STEEL
UNDERFRAME	STEEL-DURVEA
DRAFT GEAR	DURVEA
COUPLER	AAR TYPE E
BRAKE	AB
HAND BRAKE	AJAX
LINING & CEILING	PLYWOOD
INSULATION IN FLOOR, SIDES, ENDS, & CEILING	
RUNNING BOARDS	STEEL
BRAKE GEAR REGULATOR	ROYAL TYPE F

LIGHT WEIGHT, LBS.	46,900
LENGTH INSIDE	29'-2 1/2"
WIDTH INSIDE	8'-2"
HEIGHT INSIDE AT CENTER	6'-9 1/16"
YEAR BUILT	{ 01410 - 01419 1941 01420 - 01429 1942
BUILDERS	D.&R.G.W.

DENVER & RIO GRANDE WESTERN R.R.

CABOOSSES No. 01430 to 01439

CABOOSSES No. 01440 to 01449

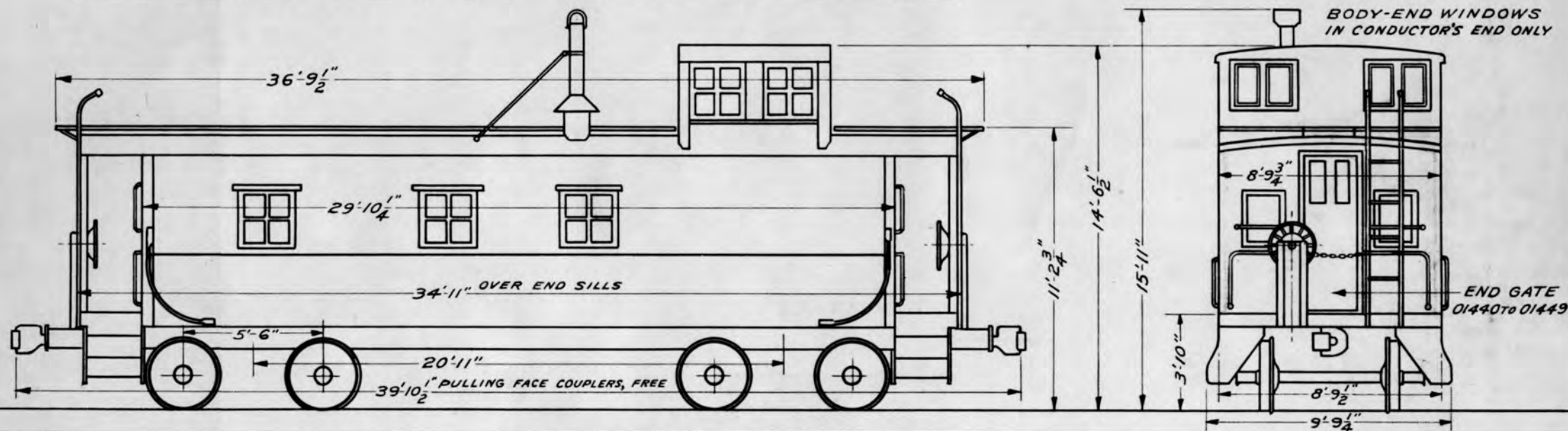
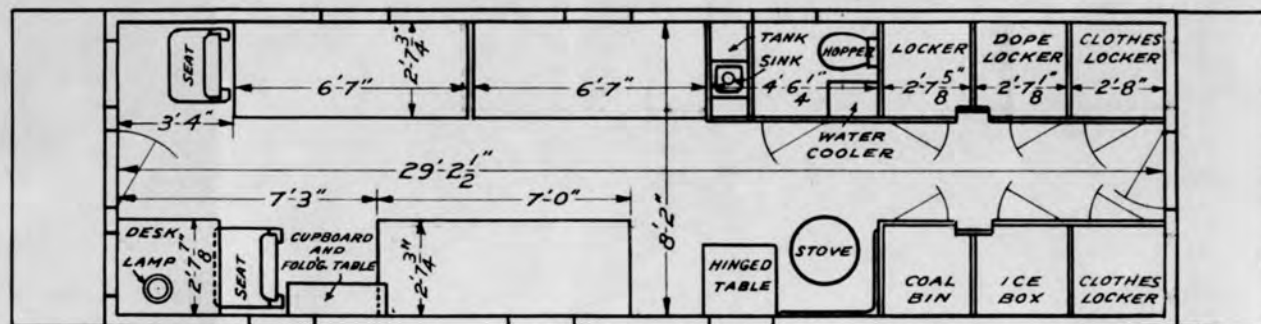

DESCRIPTION

GAUGE	4'-8 1/2"	ROOF	STEEL	LIGHT WEIGHT, LBS.	47,900
JOURNALS	4 1/4" x 8"	ENDS	STEEL	LENGTH INSIDE	29'-2 1/2"
WHEELS	33" CAST IRON	SIDES	STEEL	WIDTH INSIDE	8'-2"
TRUCK TYPE	BETTENDORF SWING	UNDERFRAME	STEEL-DURYEA	HEIGHT INSIDE AT CENTER	6'-9 11/16"
TRUCK SIDES	CAST STEEL-INTEGRAL BOXES	DRAFT GEAR	DURYEA	YEAR BUILT - 01430-01439	1944
TRUCK BOLSTER	CAST STEEL	COUPLER	AAR TYPE E	YEAR BUILT - 01440-01449	1944 & 1945
SIDE BEARINGS	BARBER	BRAKE	AB	BUILDERS	D.&R.G.W.
		HAND BRAKE	AJAX		
		LINING & CEILING	PLYWOOD		
		INSULATION IN FLOOR, SIDES, ENDS, & CEILING			
		RUNNING BOARDS	STEEL		
		BRAKE GEAR REGULATOR	ROYAL TYPE F		

DENVER & RIO GRANDE WESTERN R.R.
CABOOSE No. 01433

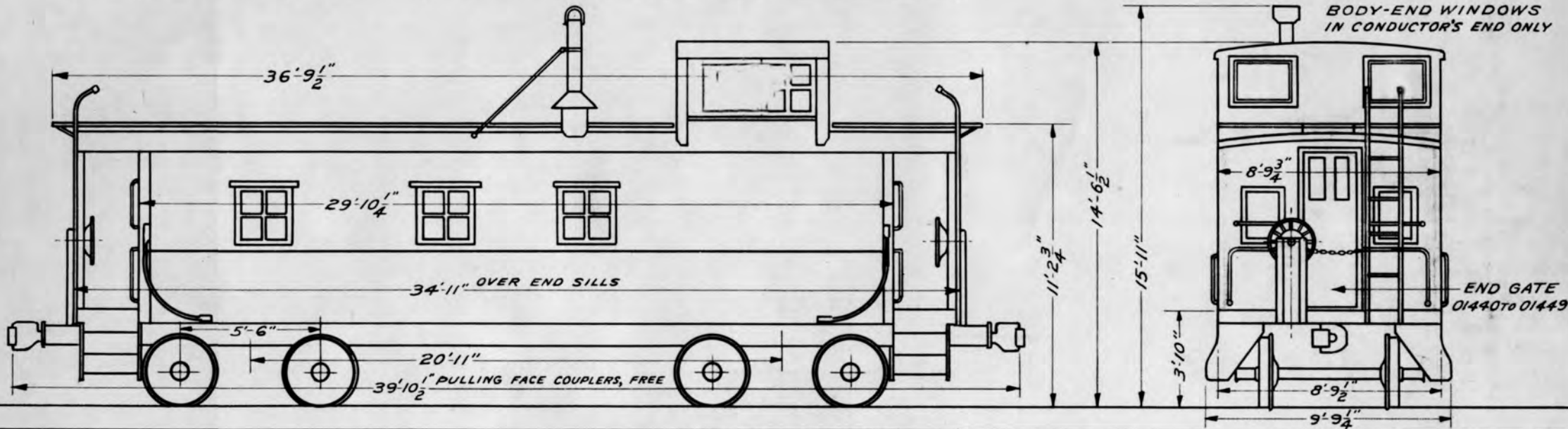
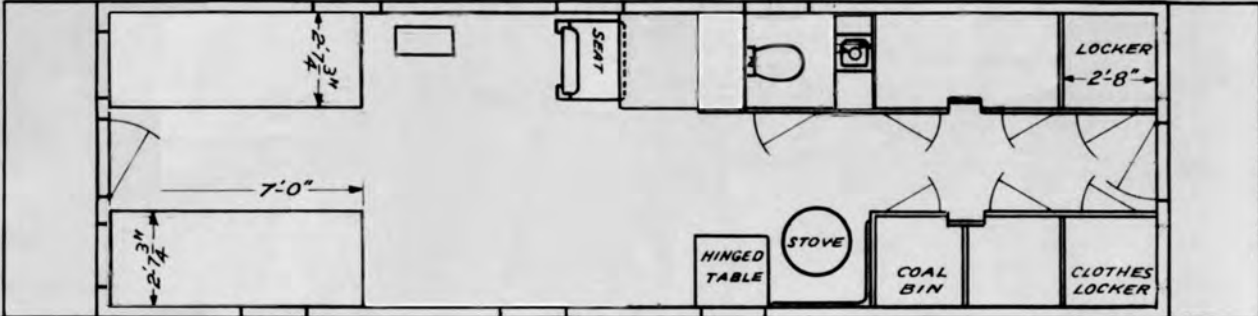

DESCRIPTION

GAUGE -----	4'-8 1/2"	ROOF -----	STEEL	LIGHT WEIGHT, LBS. -----	47,900
JOURNALS -----	4 1/4" x 8"	ENDS -----	STEEL	LENGTH INSIDE -----	29'-2 1/2"
WHEELS -----	33" CAST IRON	SIDES -----	STEEL	WIDTH INSIDE -----	8'-2"
TRUCK TYPE -----	BETTENDORF SWING	UNDERFRAME -----	STEEL-DURYEA	HEIGHT INSIDE AT CENTER -----	6'-9 11/16"
TRUCK SIDES -----	CAST STEEL-INTEGRAL BOXES	DRAFT GEAR -----	DURYEA	YEAR BUILT - 01430-01439 -----	1944
TRUCK BOLSTER -----	CAST STEEL	COUPLER -----	AAR TYPE E	YEAR BUILT - 01440-01449 -----	1944 & 1945
SIDE BEARINGS -----	BARBER	BRAKE -----	AB	BUILDERS -----	D.&R.G.W.
		HAND BRAKE -----	AJAX		
		LINING & CEILING -----	PLYWOOD		
		INSULATION IN FLOOR, SIDES, ENDS, & CEILING -----			
		RUNNING BOARDS -----	STEEL		
		BRAKE GEAR REGULATOR -----	ROYAL TYPE F		

DENVER & RIO GRANDE WESTERN R.R.
CABOOSES 01450 TO 01459 - RADIO EQUIPPED
CABOOSES 01460 TO 01469 - NOT RADIO EQUIPPED

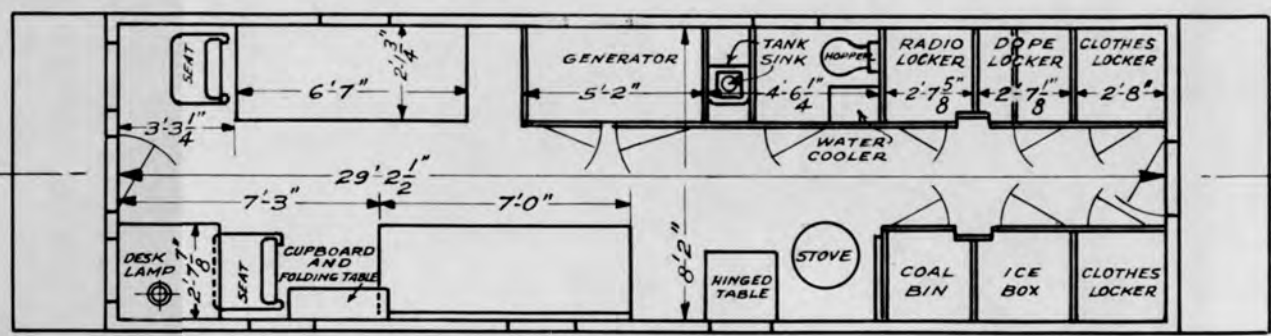

BODY END WINDOWS
IN CONDUCTOR'S END ONLY

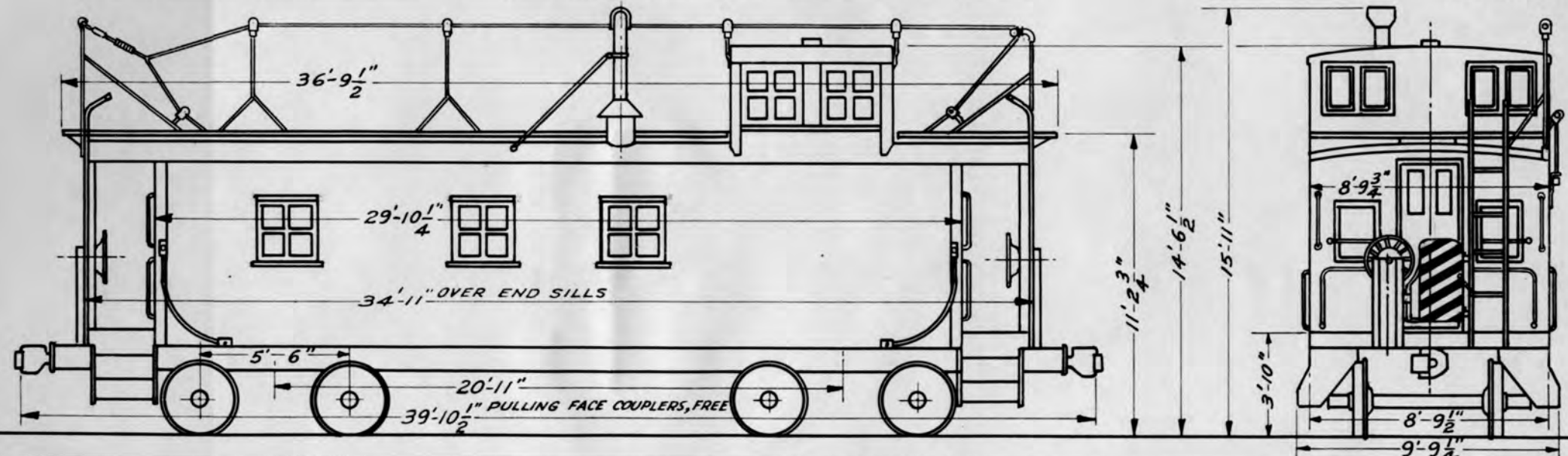

DESCRIPTION

GAUGE	4'-8 1/2"	ROOF	STEEL	LIGHT WEIGHT, LBS.	47,900
JOURNALS	4 1/4" X 8"	ENDS	STEEL		
WHEELS	33" CAST IRON	SIDES	STEEL	WIDTH INSIDE	8'-2"
TRUCK TYPE	BETTENDORF SWING	UNDERFRAME	STEEL-DURYEA	HEIGHT INSIDE AT CENTER	6'-9 1/16"
TRUCK SIDES	CAST STEEL-INTEGRAL BOXES	DRAFT GEAR	DURYEA	YEAR BUILT-01450-01459 SERIES	1947
TRUCK BOLSTER	CAST STEEL	COUPLER	AAR TYPE E	YEAR BUILT-01460-01469 SERIES	1951
SIDE BEARINGS	BARBER	BRAKE	AB	BUILDERS	D.&R.G.W.
		HAND BRAKE	AJAX		
		LINING & CEILING	PLYWOOD		
		INSULATION IN FLOOR, SIDES, ENDS & CEILING			
		RUNNING BOARDS	STEEL		
		BRAKE GEAR REGULATOR	AJAX TYPE A		

DENVER & RIO GRANDE WESTERN R.R.
CABOOSES No's. 01470 to 01490

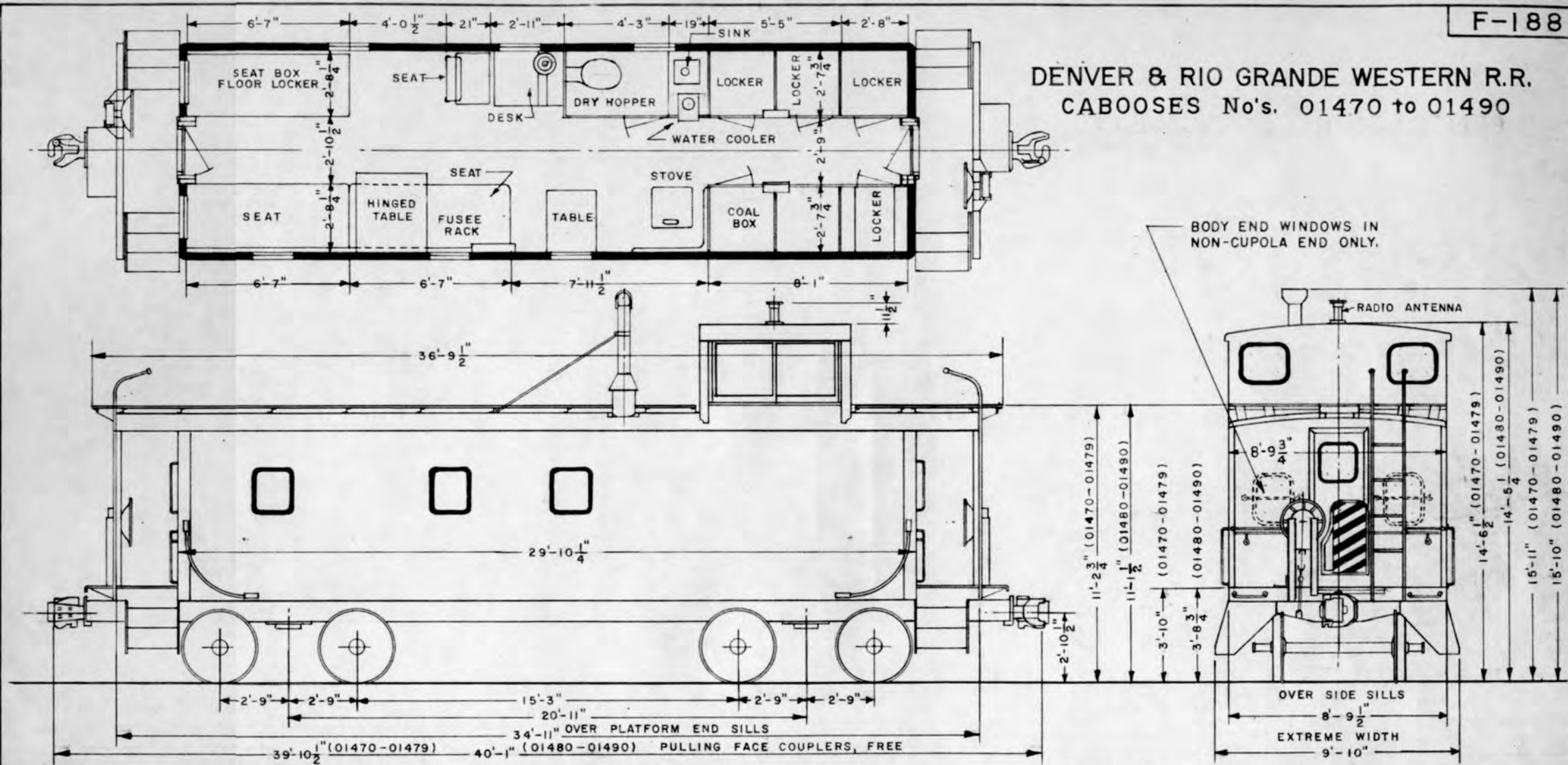

DESCRIPTION

GAUGE	4'-8 1/2"	SUPERSTRUCTURE	STEEL	LIGHT WEIGHT, LBS. AV. (01470-01479)	47,200
JOURNALS	4 1/4" x 8"	UNDERFRAME	STEEL-DURYEA	LIGHT WEIGHT, LBS. AV. (01480-01490)	49,900
WHEELS	33" CAST IRON	DRAFT GEAR	DURYEA	LENGTH INSIDE	29'-2 1/2"
TRUCK TYPE	BETTENDORF SWING	COUPLER	A A R TYPE E	WIDTH INSIDE	8'-2"
TRUCK SIDES	CAST STEEL-INTEGRAL BOXES	BRAKE	A B	HEIGHT INSIDE AT CENTER	6'-9 11/16"
TRUCK BOLSTER	CAST STEEL	HAND BRAKE	AJAX	YEAR BUILT (01470-01479)	1955
	01470 - 01479	LINING & CEILING	PLYWOOD	YEAR BUILT (01480-01490)	1959
SIDE BEARINGS	STANDARD CAR TRUCK-ROLLER	INSULATION-IN FLOOR	INSULITE	BUILDER	D & R G W
	01480- 01490	INSULATION IN SIDES, ENDS, CEILING	GUSTIN-BACON-ULTRALITE		
SIDE BEARINGS	BARBER - ROLLER	RUNNING BOARDS	APEX TRI-LOCK TYPE A-I		
		BRAKE SLACK ADJUSTER (01470-01479)	ROYAL TYPE F		

DENVER & RIO GRANDE WESTERN R.R.

CABOOSES No's. 01500 TO 01514

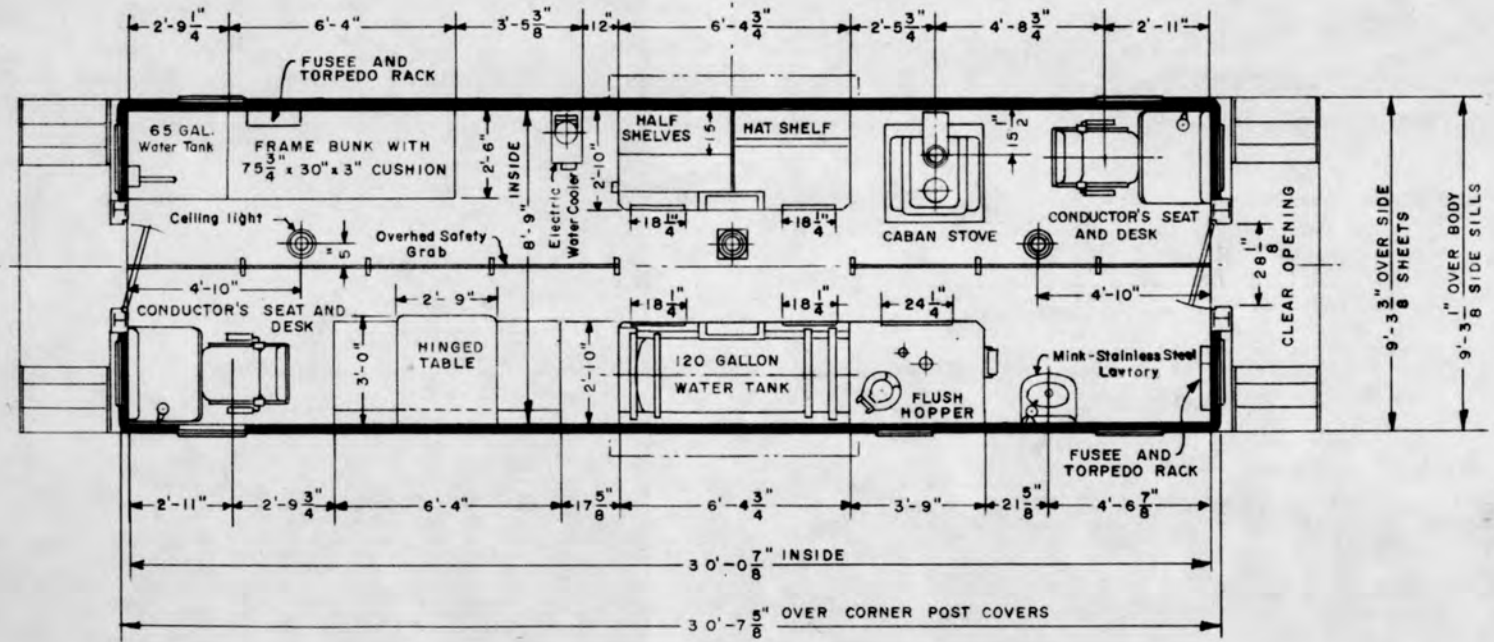
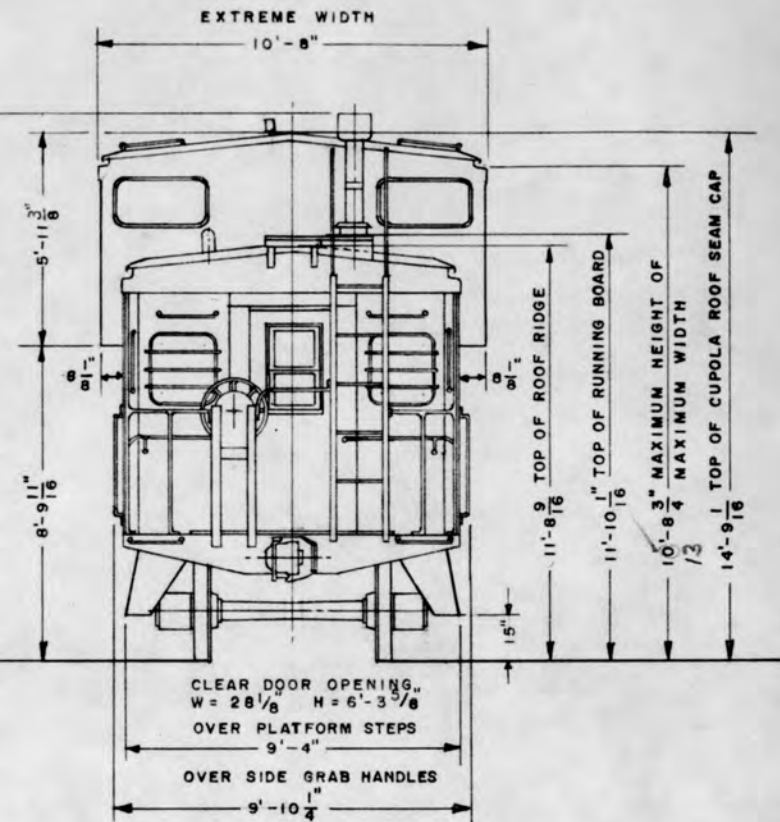
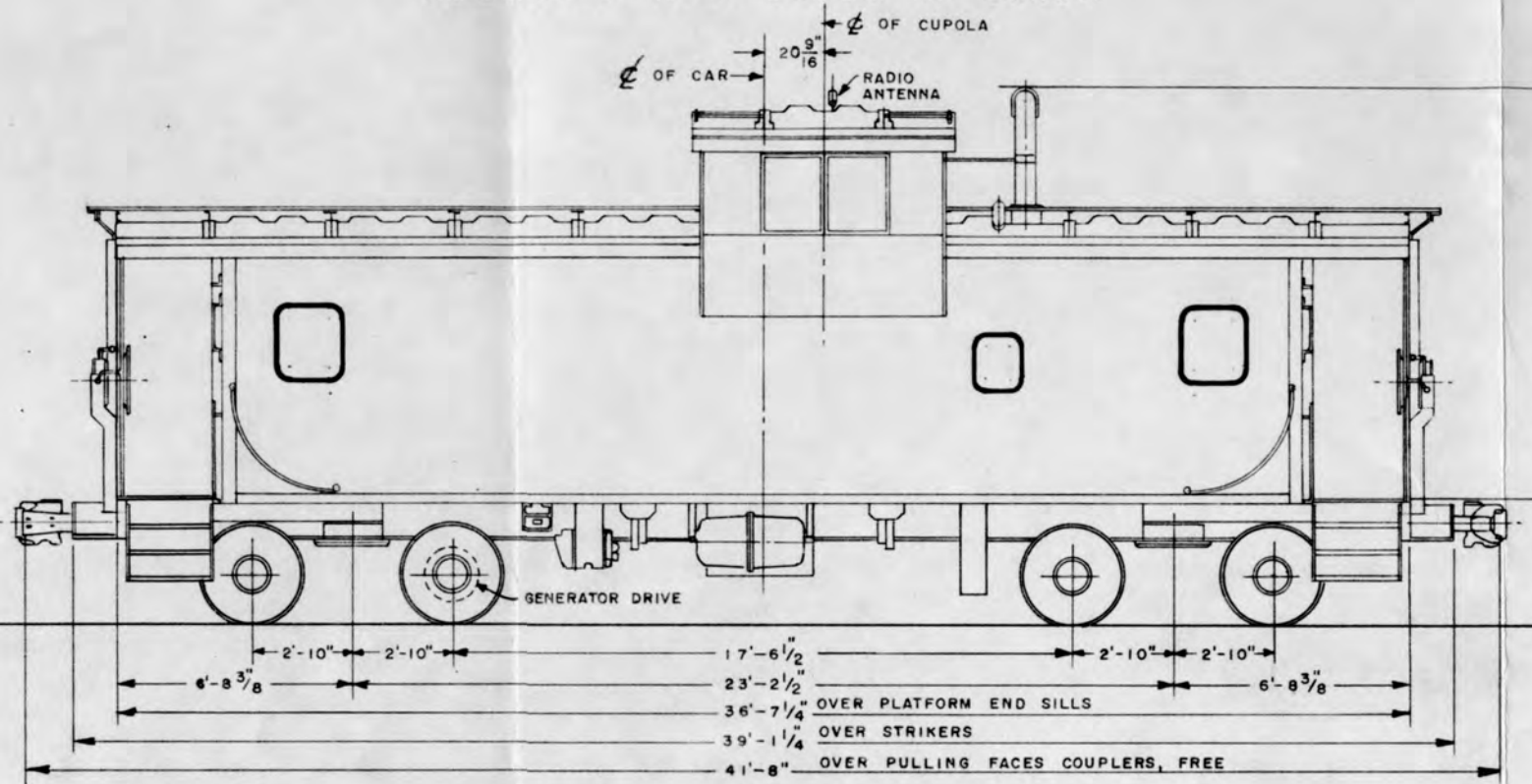
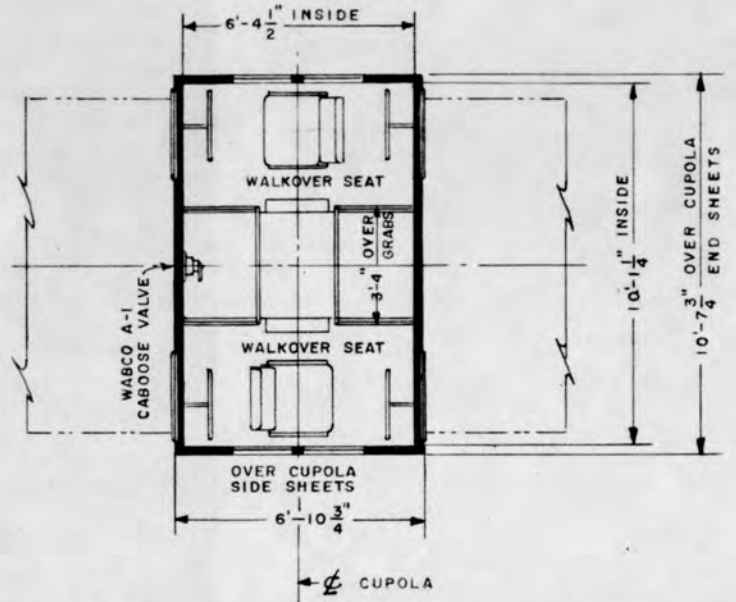

DESCRIPTION	
GAUGE	4'-8 1/2"
JOURNALS	5 1/2" X 10" TIMKEN ROLLER BEARINGS
WHEELS	33" I-W STEEL
AXLES	D-11-65
AXLE GENERATOR DRIVE	DAYCO
TRUCK TYPE	BARBER-BETTENDORF SWING MOTION
TRUCK SIDES	NARROW PEDESTAL TYPE
SIDE BEARINGS	STUCKI ROLLER
BRAKE BEAMS	BUFFALO-UNIT TYPE NO. 18
BRAKE SHOES	COBRA V-139
ROOF	STANDARD RAILWAY EQUIPMENT CO.-DIAGONAL PANEL
SUPERSTRUCTURE	COPPER BEARING STEEL
FLOOR	2" X 8" T. & G. YELLOW PINE
FLOOR COVERING	RUSSELOID
LINING-BODY	14 GA. COPPER BEARING STEEL
LINING-CUPOLA	16 GA. COPPER BEARING STEEL
INSULATION	3" FIBREGLASS GUSTIN-BACON
UNDERFRAME	WAUGH CUSHION TYPE-10 1/2"
DRAFT GEAR	MINER A-22-XL
COUPLER	(B-E60A-HT) 6 1/4" X 8" X 21 1/2" SHANK, TYPE E
BRAKE	CYLINDER BUSHED TO 7 1/2" DIA. ABD 1012
BRAKE SLACK ADJUSTER	ELLCON NATIONAL TYPE 1340
HAND BRAKE	KLASING TYPE 1150
PLATFORM AND PLATFORM STEPS	APEX
RUNNING BOARDS	APEX TYPE A-1
LIGHT WEIGHT, LBS.	56,600
LENGTH INSIDE	30'-0 7/8"
WIDTH INSIDE	8'-9"
HEIGHT INSIDE	6'-10 1/8"
YEAR BUILT	1966
BUILDER	INTERNATIONAL CAR CORPORATION