

CLASS
BA-50-1

BALLAST CAR
100000 LBS. CAPACITY
SPEC. NO. 64

CA NO'S.
85500-85999

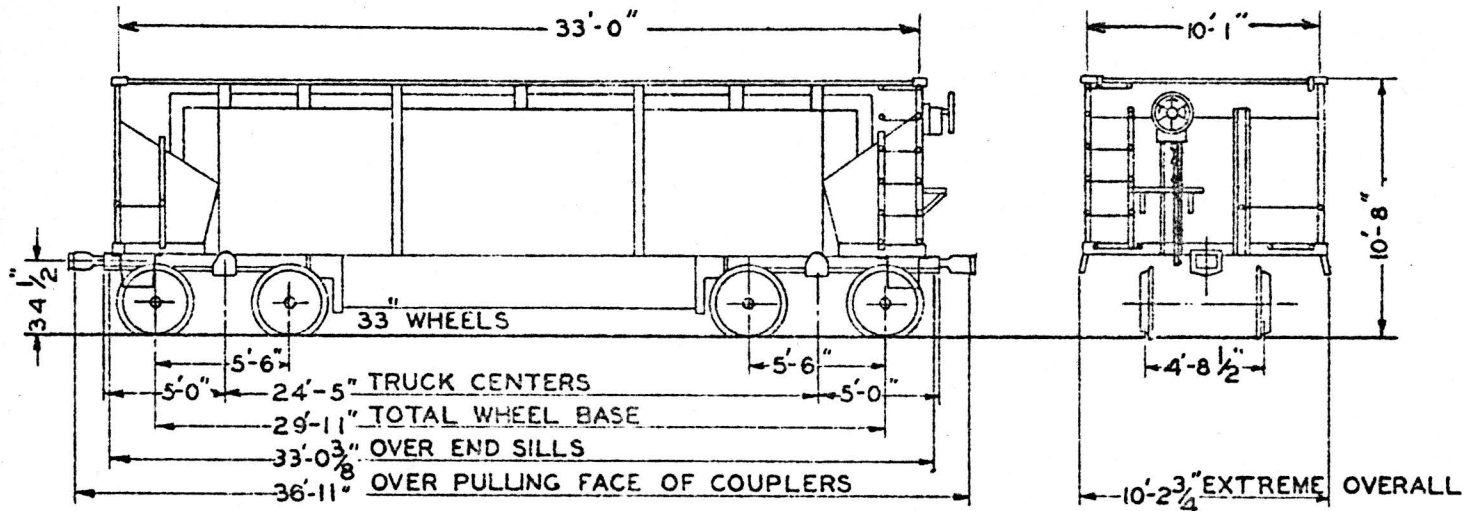

LENGTH-INSIDE	33'-0"	CAR BUILDER	NO. CARS BUILT	YEAR BUILT	REFERENCE DRAWINGS
WIDTH-INSIDE	10'-1"	PULLMAN CO.	500	1926	GENERAL DESIGN C-3735
HEIGHT-INSIDE-AVERAGE	5'-10"				BRAKE ARR'GT. C-3784
CUBIC CAPACITY	1951 CU. FT.				TRUCK " C-4087
WT. OF EACH TRUCK - A. R. A.	7810#				DOOR OPERATING ARR'GT. C-3739
LT. WEIGHT OF CAR COMPLETE	48800#				
UNDERFRAME RIVETED	CAR BUILDER				
SUPERSTRUCTURE - STEEL RIVETED					

AIRBRAKE	K-2
BRAKE BEAMS & SLI. CHAIR	CRECO#2+
BRAKE HANGER	SCHAEFER
" STEP	VILOCO
COUPLER	TYPE 'E'
" YOKE	CAST STEEL
" RELEASE RIGGING	CARMER
DRAFT GEAR	FRICTION
" KEY RETAINER	A. R. A.
DOORS	8-SIDE-DUMP
"	8-CENTER-DUMP
HANDBRAKE	AJAX
AXLE-JOURNALS	5-1/2 X 10"
JOURNAL BOX LID	ASCO
TRUCK BOLSTERS	BUCKEYE
" SIDE FRAMES	A. S. F.
" BEARINGS	WINE
" ROLLER DEVICE	BARBER
WHEELS-CAST IRON	33"

UNION PACIFIC RAILROAD CO.
RESEARCH AND
MECHANICAL STANDARDS

					DATE	DIAGRAM
						F-8-2
					ISSUE	DRAWN
						7-12-41

CLASS
BA-50-2

BALLAST CAR
100000 LBS. CAPACITY
SPEC. NO. 64-A

COR NO'S.
85000-85499

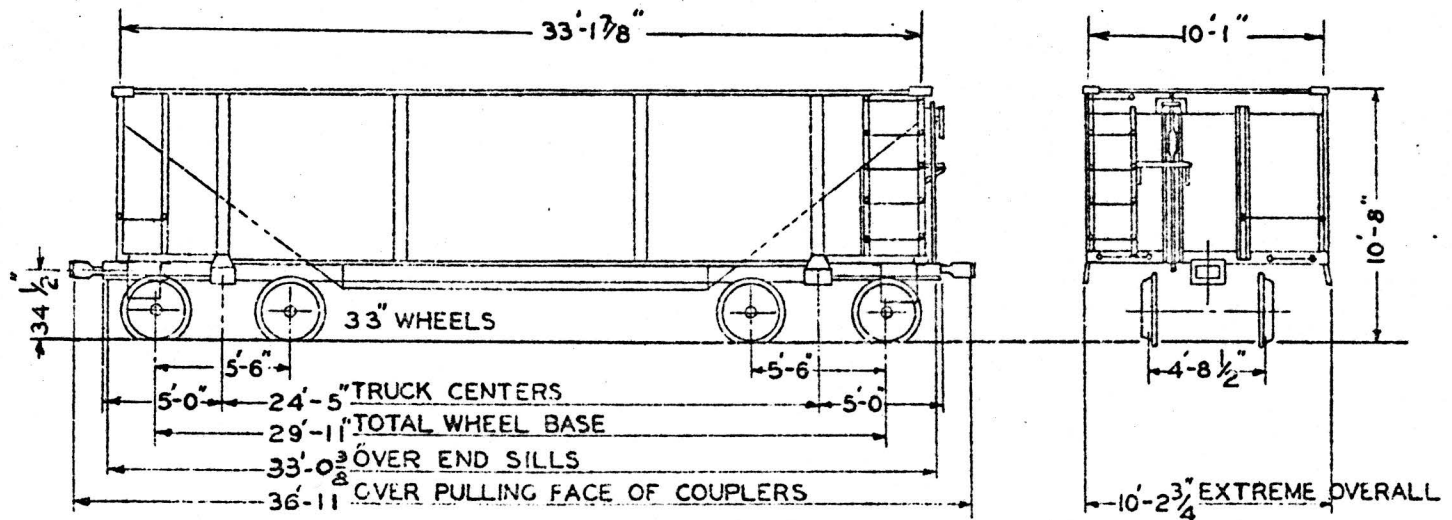

LENGTH-INSIDE	33'-1-7/8"	CAR BUILDER	NO. CARS BUILT	YEAR BUILT	REFERENCE DRAWINGS
WIDTH - "	10'-1"	AM. CAR & FDY. CO.	500	1926	GENERAL DESIGN C-4015
HEIGHT - "	5'-11"				BRAKE ARRGT. C-4016
CUBIC CAPACITY	1982 CU. FT.				TRUCK " C-4087
WT. OF EACH TRUCK-ARA.	7810 *				
LT. WEIGHT OF CAR COMPLETE	46000 *				
UNDERFRAME - STEEL RIVETED	CAR BUILDER				
SUPERSTRUCTURE STEEL RIVETED					

AIRBRAKE	K-2
BRAKE BEAM & SLIDING CHAIRS-CRECO2+	
" HANGER	SCHAEFER
" STEP	VILOCO
COUPLER	TYPE-E
" YOKE	BUCKEYE
" RELEASE RIGGING	CARMER
DRAFT GEAR	FRICTION
DROP DOOR	2-SIDE-DUMP
" "	2-CENTER "
HANDBRAKE	URECO
AXLE-JOURNALS	5-1/2'X10"
DRAFT GEAR KEY RETAINER	A.A.R.
TRUCK BOLSTERS	A.R.A. BUCKEYE
TRUCK SIDE FRAME	A.M. S. F.
" BEARING	WAUGH
" ROLLER DEVICE	BARBER
JOURNAL BOX LID	ASCO
WHEELS-CAST IRON	33"

UNION PACIFIC RAILROAD CO.
RESEARCH AND
MECHANICAL STANDARDS

				ISSUE DATE	DIAGRAM F-8-3
					DRAWN 7-12-41

CLASS
BA-50-3

BALLA T CAR
100000 LBS CAPACITY
SPEC. NO. 64-B

C NO'S.
86000-86999

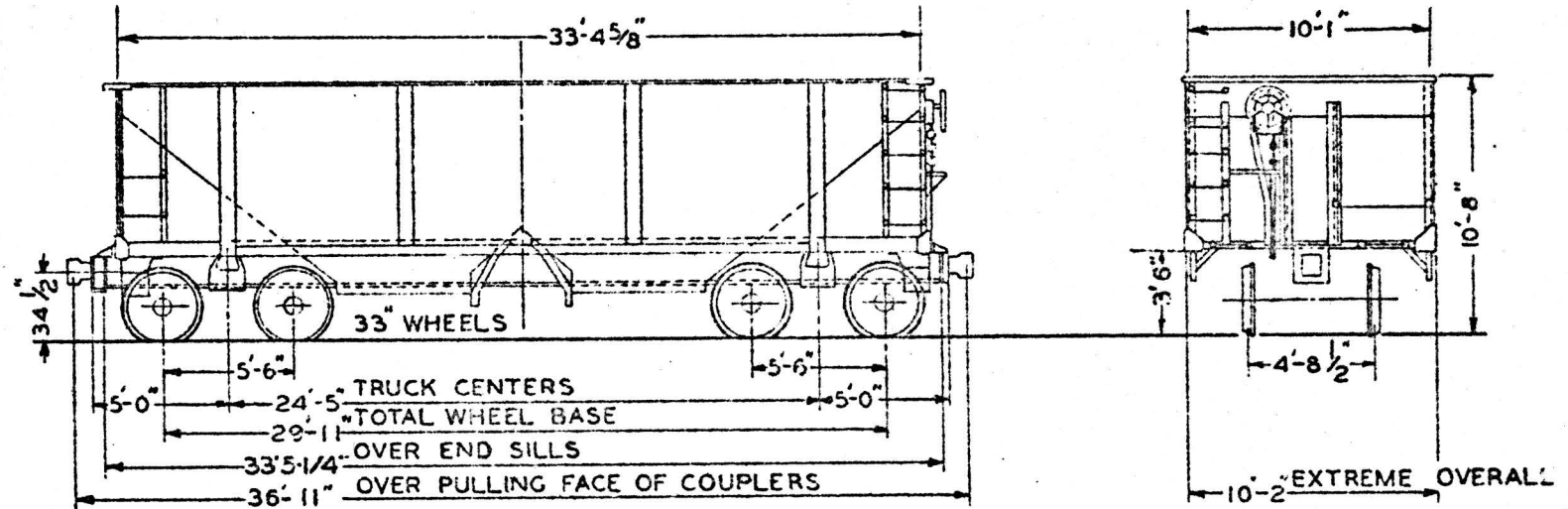

LENGTH INSIDE	33'-4-5/8"	CAR BUILDERS	NOCARS BUILT	YEAR BUILT	REFERENCE DRAWINGS
WIDTH INSIDE	10'-1"	A.C.&F.CO.	1000	1931	GENERAL DESIGN 246 C6899
HEIGHT INSIDE-AVERAGE	5'-10-1/4"				BRAKE ARR'GT. 158 C6703
CUBIC CAPACITY-LEVEL FULL	1970 CU. FT.				TRUCK ARR'GT. 423 C8701
WT. OF EACH BARBER STABILIZED TRUCK	7200 LBS.				DOOR ARR'GT. 214 C6702
LIGHT WT. OF CAR COMPLETE	45700 LBS.				
UNDERFRAME - RIVETED-AMER. CAR & FOUNDRY CO.					
SUPERSTRUCTURE STEEL-RIVETED					

AIR BRAKE - AB	WESTINGHOUSE	TRUCK ROLLER DEVICE -	BARBER
BRAKE BEAM, SUPP. & CHAIRS	CRECOR 2	SPRING PLATES	AMER. LOCO.
BRAKE BALANCER	WINE	WHEELS	CAST IRON 33"
BRAKE PIPE ANCHOR	GUSTIN-BACON	AXLE - JOURNALS	5 1/2" X 10"
BRAKE HANGER & WEAR PLATE	SCHAEFER		
BRAKE LEVER, BOTTOM CONN.	"		
BRAKE ROD JAWS	"		
BRAKE STEP	VILOCO		
COUPLER	TYPE - E		
COUPLER YOKE	CAST STEEL		
COUPLER RELEASE RIGGING	ROTARY		
CYL. FLOATING & TRK. LEVERS	SCHAEFER		
DROP DOOR MECHANISM	A.C.&F.CO.		
DRAFT GEAR	WAUGH-GOULD 403		
DRAFT KEY RETAINER	SURLOX		
HAND BRAKE	URECO		
SIDE & END LADDERS	U.P. DESIGN		
STAKE LINKS	SIDE & END		
TRUCK SIDE FRAME	BETT & ASF.		
TRUCK BOLSTER - SCULLIN & BUCKEYE			
TRUCK SIDE BEARING	ASF		

UNION PACIFIC RAILROAD CO.
RESEARCH AND
MECHANICAL STANDARDS

					ISSUE DATE	DIAGRAM
						F-8-4
						DRAWN
						7-12-41

CLASS
BA-50-4

BALLAST CAR
100000 LBS CAPACITY

C/ NO'S.
87000-87999

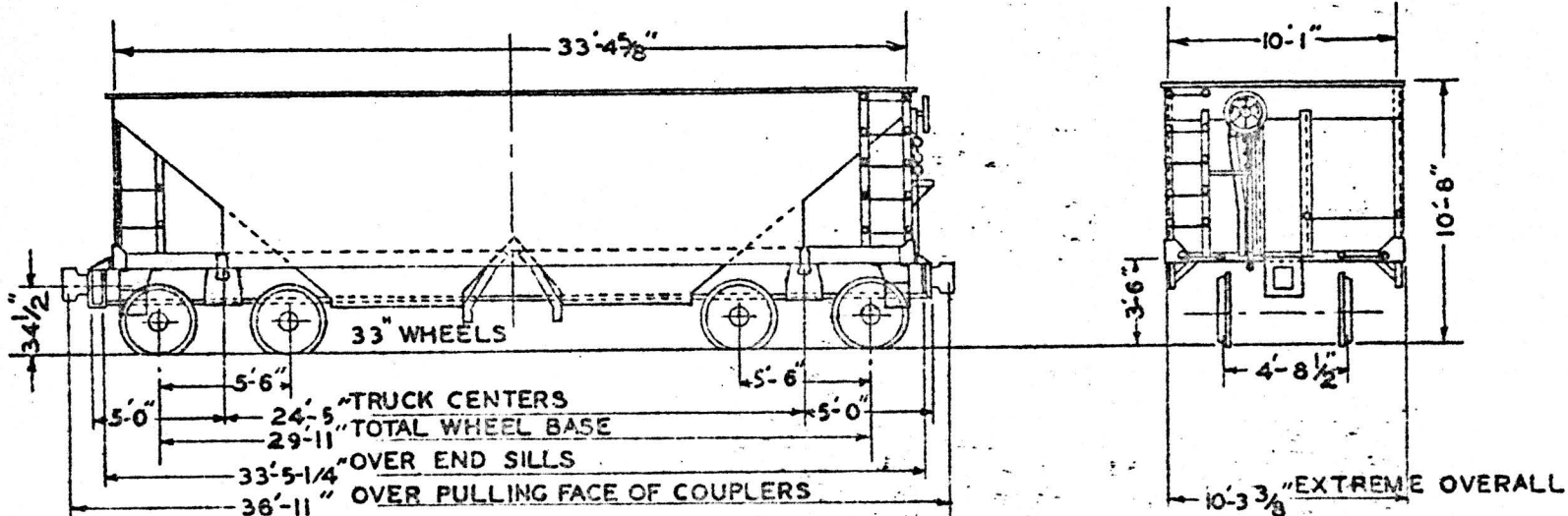

LENGTH INSIDE	33-4-5/8	CAR BUILDERS	NO. CARS BUILT	YEAR BUILT	REFERENCE DRAWINGS
WIDTH INSIDE	10'-1"	A.C. & F. CO.	1000	1941	GENERAL DESIGN 246 C-8000
HEIGHT INSIDE AVERAGE	5'-10-1/4				BRAKE ARR'GT. 156 C-8001
CUBIC CAPACITY - LEVEL FULL	1970 CU.FT.				TRUCK ARR'GT. 424 C-8003
WT. OF EACH SPRING PLANK TYPE BARBER STAB. TRUCK	7100 LBS.				DOOR ARR'GT. 214 C-8002
LIGHT WEIGHT OF CAR COMPLETE	44800 - LBS				
UNDERFRAME STEEL-RIVETED AMER. CAR & FOUNDRY CO.					

AIR BRAKE A-B	N.Y. & WESTINGHOUSE	AXLE - JOURNALS	5-1/2" X 10"
BRAKE BEAM SUPR. & CHAIRS	GRECO-NO. 3	TRUCK BOLSTER	SCULLIN & BUCKEYE
BRAKE HANGERS & WEAR PLATE	SCHAEFER	TRUCK SIDE FRAMES	BETTENDORF CO.
BRAKE BALANCER	WINE	TRUCK SPRING & PLATE	A.M. LOCO. CO.
BRAKE LEVER BOTTOM CONN.	SCHAEFER	TRUCK STABILIZER	STD. CAR TRK. CO.
BRAKE PIPE ANCHOR	GUSTIN - BACON	WHEEL ONE-WEAR 33"	WROT STEEL
BRAKE ROD JAWS	SCHAEFER		
BRAKE STEP	VILOCO		
BOTTOM ROD GUARD	CHIC. RY. EQT. CO.		
COUPLER BOTT. M. OPER'G.	TYPE E		
COUPLER CENTERING DEV.	STD. RY. EQT. CO.		
COUPLER RELEASE RIGGING	ROTARY		
COUPLER YOKE	CAST STEEL		
CYL. FLOATING & TRK. LEVERS	SCHAEFER		
DEFECT CARD HOLDER	REAL		
DROP DOOR MECHANISM	A.C. & F. CO.		
DRAFT GEAR	FRICITION		
DRAFT KEY RETAINER	SURE LOX		
HAND BRAKE	POWER		

UNION PACIFIC RAILROAD CO.
RESEARCH AND
MECHANICAL STANDARDS

				ISSUE DATE	DIAGRAM F-8-5
					DRAWN 7-12-41

ASS
Hr-50-5

HOPPER CAR

100000 LBS CAPACITY

CAR NO'S
U.P. 88000-88899
O.W. 88900-88999

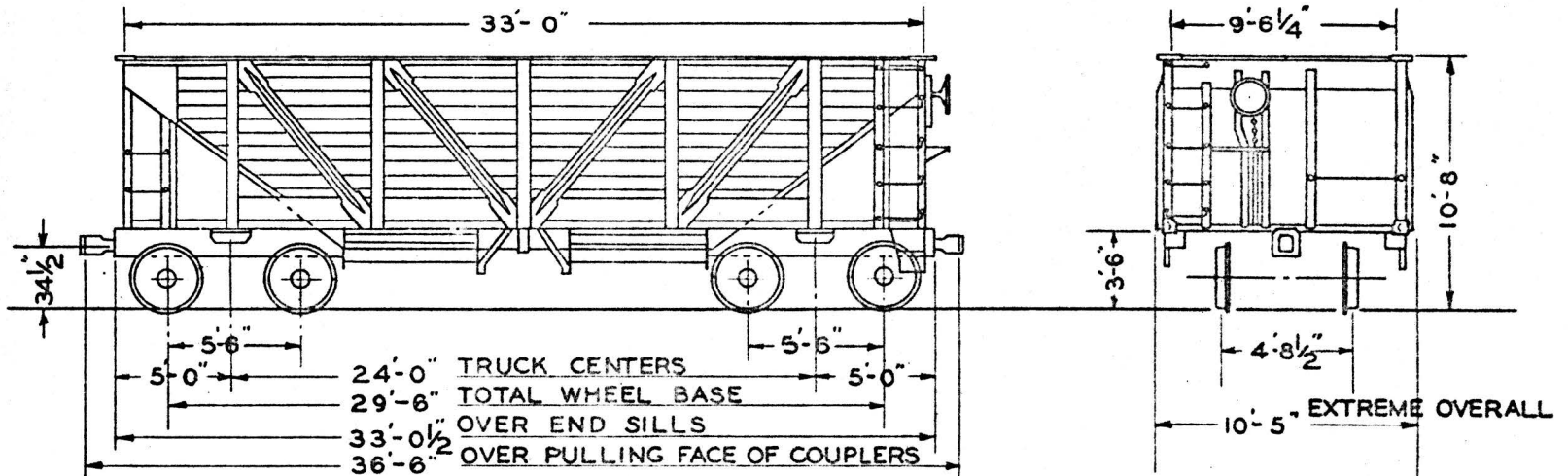

LENGTH INSIDE	33'-0"	CAR BUILDER	NO. CARS BUILT	YEAR BUILT	REFERENCE DRAWING
WIDTH INSIDE	9'-6 1/4"	A.C.&F. CO.	1000	1943	GENERAL DESIGN
HEIGHT INSIDE AVERAGE	5'-10 1/4"				BRAKE ARRGT.
CUBIC CAPACITY - LEVEL FULL	1792 CU. FT.				TRUCK ARRGT.
WT. OF EACH BARBER STABILIZED TRUCK	7200 LBS.				DOOR ARRGT.
LT. WT. OF CAR COMPLETE	SEE NOTE				
UNDERFRAME - STEEL - RIVETED	AMER. CAR & FDRY. CO.				
SUPERSTRUCTURE - COMPOSITE CONSTRUCTION					

		STAKE LINKS	SIDE & END
AIR BRAKE - AB	WESTINGHOUSE		
AXLE - JOURNALS	5 1/2" X 10"	TRUCK SIDE FRAME	SCULLIN & A.S.F.
BRAKE BEAMS	A.A.R. #3	TRUCK BOLSTER	BUCKEYE
BRAKE BEAM SUPP. & CHAIRS	CRECO	TRUCK SIDE BEARING	FRICTION TYPE
BRAKE BALANCER	ROYAL - TYPE-K	SPRING PLATES	UNIVERSAL "U.X.S."
BRAKE PIPE ANCHOR	GUSTIN BACON	WHEELS ONE WEAR WROT ST.	33"
BRAKE HANGER & WEAR PLATE	SCHAEFER	TRUCK STABILIZER	STD. CAR TRK. CO.
BRAKE LEVER BOTTOM CONN.	"	JOURNAL BOX LID	N.M. & ST. C. CO.
BRAKE ROD JAWS	"		
BRAKE STEP	TRANS. SPECIALTIES CO.		
COUPLER	NATL. MALL.		
COUPLER YOKE	BUCKEYE UNIVERSAL		
COUPLER RELEASE RIGGING	STD. RWY. EUIP		
CYL. FLOATING & TRK. LEVERS	SCHAEFER		
DROP DOOR MECHANISM	ROGER BALLAST		
DRAFT GEAR	MINER, WAUGH		
	CARD - WEST. PEERLESS		
DRAFT KEY RETAINER	SURELOX		
HAND BRAKE	SUPERIOR, UNIVERSAL		
	MINER, AJAX, EQUIPCO		
DEFECT CARD HOLDER	REAL		

NOTE:
LT. WT. HIGH TENSILE SIDE FRAMES & BOLSTERS-45000 LBS.
LT. WT. GRADE - B SIDE FRAMES & BOLSTERS-45500 LBS.

UNION PACIFIC RAILROAD CO.
RESEARCH AND
MECHANICAL STANDARDS

					ISSUE DATE	DIAGRAM
						F-8-7
						DRAWN
						8-1-43